

LMG365xR025 650V 25mΩ GaN FET With Integrated Driver and Protection

1 Features

- 650V 25mΩ GaN power FET with integrated gate driver
 - >200V/ns FET hold-off
 - Adjustable slew rates for optimization of switching performance and EMI mitigation
 - 10V/ns to 100V/ns turn-on slew rates
 - 10V/ns to full speed turn-off slew rates
 - Operates with supply pin and input logic pin voltage range from 9V to 26V
- Robust Protection
 - Cycle-by-cycle overcurrent and latched short-circuit protection with <300ns response
 - Withstands 720V surge while hard-switching
 - Self-protection from internal overtemperature and UVLO monitoring
- Advanced power management
 - LMG3656R025 includes zero-voltage detection (ZVD) feature that facilitates soft-switching converters
 - LMG3657R025 includes zero-current detection (ZCD) feature that facilitates soft-switching converters
- 9.8mm × 11.6mm TOLL package with thermal pad

2 Applications

- [Merchant network and server PSU](#)
- [Merchant telecom rectifiers](#)
- Solar inverters and industrial motor drives
- Uninterruptible power supplies

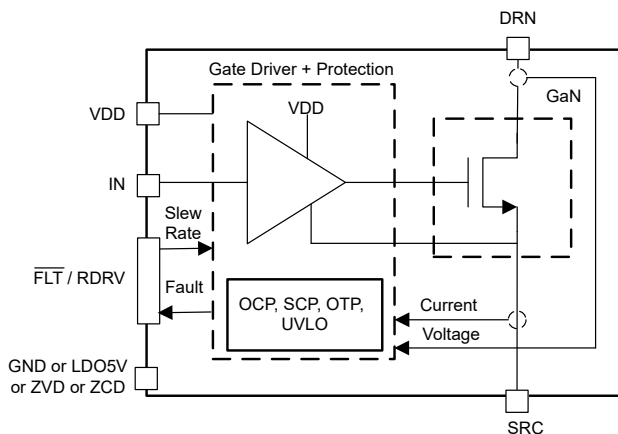

Simplified Block Diagram

3 Description

The LMG365xR025 GaN FET with integrated driver and protection is targeted at switch-mode power converters and enables designers to achieve new levels of power density and efficiency.

Adjustable gate driver strength allows the control of turn-on and maximum turn-off slew rates independently, which can be used to actively control EMI and optimize switching performance. Turn on slew rate can be varied from 10V/ns to 100V/ns, while the turn off slew rate can be limited from 10V/ns to a maximum based on the magnitude of load current. Protection features include under-voltage lockout (UVLO), cycle-by-cycle overcurrent limit, short-circuit and overtemperature protection. The LMG3651R025 provides a 5V LDO output on LDO5V pin that can be used to power external digital isolator. The LMG3656R025 includes the zero-voltage detection (ZVD) feature which provides a pulse output from the ZVD pin when zero-voltage switching is realized. The LMG3657R025 includes the zero-current detection (ZCD) feature that sets the ZCD pin high when the drain-to-source current is negative and transitions to low upon detecting the zero-crossing point.

Package Information

PART NUMBER	PACKAGE ⁽¹⁾	PACKAGE SIZE ⁽²⁾
LMG365xR025	KLA (TOLL, 9)	9.8mm x 11.6mm

- (1) For all available packages, see [Section 12](#).
 (2) The package size (length × width) is a nominal value and includes pins, where applicable.

Device Information

PART NUMBER ⁽¹⁾	LDO 5V OUTPUT	ZERO-VOLTAGE DETECTION FEATURE	ZERO-CURRENT DETECTION FEATURE
LMG3650R025	—	—	—
LMG3651R025	Yes	—	—
LMG3656R025	—	Yes	—
LMG3657R025	—	—	Yes

- (1) See the [Device Comparison](#) table.

Table of Contents

1 Features	1	8.3 Feature Description.....	15
2 Applications	1	8.4 Device Functional Modes.....	22
3 Description	1	9 Application and Implementation	23
4 Device Comparison	3	9.1 Application Information.....	23
5 Pin Configuration and Functions	4	9.2 Typical Application.....	24
6 Specifications	5	9.3 Power Supply Recommendations.....	31
6.1 Absolute Maximum Ratings.....	5	9.4 Layout.....	32
6.2 ESD Ratings.....	5	10 Device and Documentation Support	36
6.3 Recommended Operating Conditions.....	5	10.1 Receiving Notification of Documentation Updates..	36
6.4 Thermal Information.....	6	10.2 Support Resources.....	36
6.5 Electrical Characteristics.....	6	10.3 Trademarks.....	36
6.6 Switching Characteristics.....	7	10.4 Electrostatic Discharge Caution.....	36
7 Parameter Measurement Information	9	10.5 Glossary.....	36
7.1 Switching Parameters.....	9	11 Revision History	36
8 Detailed Description	12	12 Mechanical, Packaging, and Orderable Information	36
8.1 Overview.....	12	12.1 Tape and Reel Information.....	40
8.2 Functional Block Diagram.....	12		

4 Device Comparison

Table 4-1. Device Comparison

DEVICE NAME	$R_{DS(on)}$	Pin 7
LMG3650R025	25m Ω	GND
LMG3651R025		LDO5V
LMG3656R025		ZVD
LMG3657R025		ZCD
LMG3650R035	35m Ω	GND
LMG3651R035		LDO5V
LMG3656R035		ZVD
LMG3657R035		ZCD
LMG3650R070	70m Ω	GND
LMG3651R070		LDO5V
LMG3656R070		ZVD
LMG3657R070		ZCD

ADVANCE INFORMATION

5 Pin Configuration and Functions

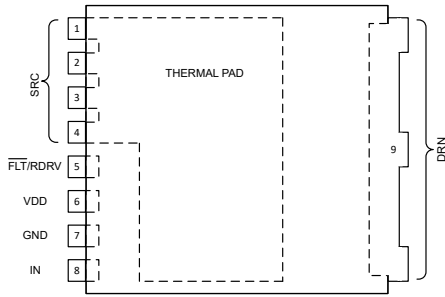

Figure 5-1. LMG3650R025, TOLL Package (Top View)

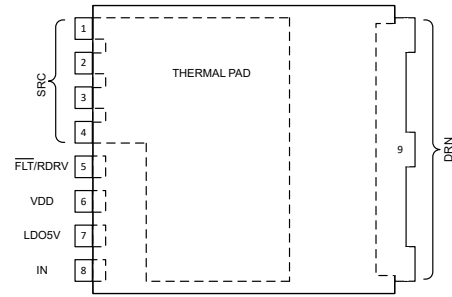

Figure 5-2. LMG3651R025, TOLL Package (Top View)

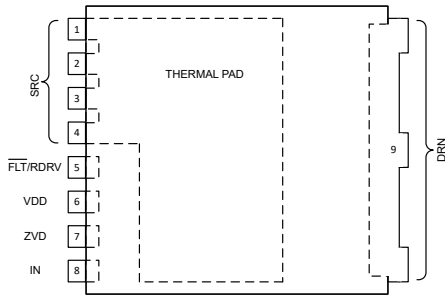

Figure 5-3. LMG3656R025, TOLL Package (Top View)

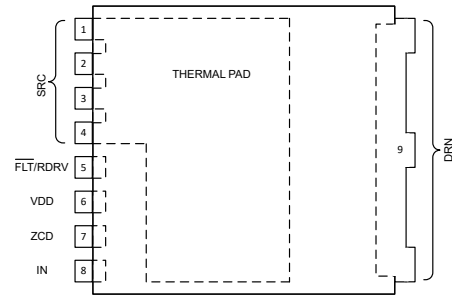

Figure 5-4. LMG3657R025, TOLL Package (Top View)

ADVANCE INFORMATION

Table 5-1. Pin Functions

NAME	PIN				TYPE (1)	DESCRIPTION
	LMG3650 R025	LMG3651 R025	LMG3656 R025	LMG3657 R025		
SRC	1 - 4	1 - 4	1 - 4	1 - 4	P	GaN FET source.
FLT/RDRV	5	5	5	5	O, I	Fault monitoring and drive strength selection pin. Connect a resistor from this pin to GND to set the turn-on drive strength. Connect a resistor in series with capacitor from this pin to GND to set the turn-off drive strength. Slew rates are set one time at the time of power up, then the pin is used for fault monitoring.
VDD	6	6	6	6	P	Device input supply
GND	7	—	—	—	G	Signal ground. Internally connected to SRC, and THERMAL PAD.
LDO5V	—	7	—	—	P	5V LDO output for external digital isolator.
ZVD	—	—	7	—	O	Push-pull digital output that provides zero-voltage detection signal to indicate if device achieves zero-voltage switching in current switching cycle.
ZCD	—	—	—	7	O	Push-pull digital output that sets ZCD pin high when the drain-to-source current is negative and transitions to low upon detecting the zero-crossing point.
IN	8	8	8	8	I	CMOS compatible non inverting input used to turn the FET on and off
DRN	9	9	9	9	P	GaN FET drain
THERMAL PAD	—	—	—	—	—	Thermal pad.

(1) I = Input, O = Output, I/O = Input or Output, G = Ground, P = Power.

6 Specifications

6.1 Absolute Maximum Ratings

Unless otherwise noted: voltages are respect to GND/SRC⁽¹⁾

		MIN	MAX	UNIT	
V _{DS}	Drain-source voltage, FET off		650	V	
V _{DS(surge)}	Drain-source voltage, surge condition, FET off		720	V	
V _{DS(tr)(surge)}	Drain-source transient ringing peak voltage, surge condition, FET off		800	V	
	Pin voltage	VDD	-0.5	28	V
		IN	-0.5	28	V
		FLT/RDRV, ZVD (LMG3656 only), ZCD (LMG3657 only)	-0.5	5.5	V
		LDO5V (LMG3651 only)		5.5	V
I _D	Peak drain current, FET on		TBD	A	
I _{D(pulse)}	Pulse drain current, FET on, t _p < 10μs.	-100	Internally Limited	A	
T _J	Operating junction temperature	-40	175	°C	
T _{stg}	Storage temperature	-65	150	°C	

- (1) Operation outside the Absolute Maximum Ratings may cause permanent device damage. Absolute Maximum Ratings do not imply functional operation of the device at these or any other conditions beyond those listed under Recommended Operating Conditions. If used outside the Recommended Operating Conditions but within the Absolute Maximum Ratings, the device may not be fully functional, and this may affect device reliability, functionality, performance, and shorten the device lifetime.

6.2 ESD Ratings

			VALUE	UNIT
V _(ESD)	Electrostatic discharge	Human body model (HBM), per ANSI/ESDA/JEDEC JS-001 ⁽¹⁾	±2000	V
		Charged-device model (CDM), per ANSI/ESDA/JEDEC JS-002 ⁽²⁾	±500	

- (1) JEDEC document JEP155 states that 500-V HBM allows safe manufacturing with a standard ESD control process.
(2) JEDEC document JEP157 states that 250-V CDM allows safe manufacturing with a standard ESD control process.

6.3 Recommended Operating Conditions

Unless otherwise noted: voltages are respect to GND/SRC

		MIN	NOM	MAX	UNIT
	Supply voltage	VDD	9	26	V
	Input voltage	IN	0	26	V
I _D	Drain current, FET on			30	A
	Positive source current	LDO5V (LMG3651 only)		25	mA
RDRV _{on}	Resistance from external turn-on slew rate control resistor between FLT/RDRV to GND	29.4		open	kΩ
RDRV _{off}	Resistance and capacitance from external turn-off slew rate control series resistor and capacitor configuration between FLT/RDRV to GND	2		open	kΩ
CDRV _{off}		0		680	pF

6.4 Thermal Information

THERMAL METRIC ⁽¹⁾		KLA (TOLL)	UNIT
		9 PINS	
R _{θJC(bot)}	Junction-to-case (bottom) thermal resistance	0.25	°C/W

(1) For more information about traditional and new thermal metrics, see the [Semiconductor and IC Package Thermal Metrics](#) application report.

6.5 Electrical Characteristics

Unless otherwise noted: voltage, resistance, capacitance, and inductance are respect to GND/SRC; $-40^{\circ}\text{C} \leq T_J \leq 150^{\circ}\text{C}$; VDD = 12V; FLT/RDRV resistances RDRV_{on} & RDRV_{off} are open

PARAMETER		TEST CONDITIONS	MIN	TYP	MAX	UNIT
GAN POWER FET						
R _{DS(on)}	Drain-source on resistance	T _J = 25°C, I _L = 16A		25	38	mΩ
		T _J = 150°C, I _L = 16A		55		mΩ
V _{SD}	Source-drain third-quadrant voltage	T _J = 25°C, I _{SD} = 0.1A		1.8		V
		T _J = 150°C, I _{SD} = 0.1A		1.8		V
		T _J = 25°C, I _{SD} = 20A		2.9		V
		T _J = 150°C, I _{SD} = 20A		3		V
I _{DSS}	Drain leakage current	T _J = 25°C, V _{DS} = 650V		TBD		μA
		T _J = 150°C, V _{DS} = 650V		TBD		μA
Q _{OSS}	Output charge	V _{DS} = 400V		183		nC
C _{OSS}	Output capacitance	V _{DS} = 400V		252	361	pF
E _{OSS}	Output capacitance stored energy	V _{DS} = 400V		23	36	μJ
C _{OSS(tr)}	Time related effective output capacitance	V _{DS} = 400V		458		pF
C _{OSS(er)}	Energy related effective output capacitance	V _{DS} = 400V		292		pF
Q _{RR}	Reverse recovery charge			0		nC
OVERCURRENT AND SHORT-CIRCUIT PROTECTIONS						
I _{T(OC)}	Overcurrent fault - threshold current		47	51	56	A
V _{T(idsat)}	Saturation current detection - threshold voltage		8.7	9	9.6	V
OVERTEMPERATURE PROTECTION						
T _{T+}	Temperature fault - positive-going threshold temperature			190		°C
T _{T(hyst)}	Temperature fault - threshold temperature hysteresis			20		°C
IN						
V _{IN,IT+}	Positive-going input threshold voltage		1.7	2	2.45	V
V _{IN,IT-}	Negative-going input threshold voltage		0.7	1	1.3	V
V _{IN,IT(hyst)}	Input threshold voltage hysteresis			1		V
R _{PDN}	Pull-down input resistance		115	150	185	kΩ
FLT/RDRV						
V _{OL}	Low-level output voltage	Output sink 8mA		0.2	0.4	V
V _{OH}	High-level output voltage	Output source 8mA	4.6	4.8		V
VDD						
I _{VDD(ON)}	Quiescent current when FET is ON	I _N =1		2.7	16	mA
I _{VDD(OFF)}	Quiescent current when FET is OFF	I _N =0		0.7	1.1	mA
I _{VDD(op)}	Operating current at 140 kHz	f _{sw} = 140kHz, V _{bus} = 400V, Hard-switched, 50% duty cycle.		5	10	mA

Unless otherwise noted: voltage, resistance, capacitance, and inductance are respect to GND/SRC; $-40^{\circ}\text{C} \leq T_J \leq 150^{\circ}\text{C}$; $V_{DD} = 12\text{V}$; FLT/RDRV resistances $R_{DRV_{on}}$ & $R_{DRV_{off}}$ are open

PARAMETER		TEST CONDITIONS	MIN	TYP	MAX	UNIT
$V_{VDD, T+ (UVLO)}$	UVLO- positive-going threshold voltage		8.1	8.5	8.9	V
$V_{VDD, T- (UVLO)}$	UVLO- negative-going threshold voltage		7.6	8	8.4	V
$V_{VDD, T (hyst)}$	UVLO- threshold voltage hysteresis			0.5		V

6.6 Switching Characteristics

Unless otherwise noted: voltage, resistance, capacitance, and inductance are respect to GND/SRC; $-40^{\circ}\text{C} \leq T_J \leq 150^{\circ}\text{C}$; $V_{DD} = 12\text{V}$; FLT/RDRV resistances $R_{DRV_{on}}$ & $R_{DRV_{off}}$ are open

PARAMETER		TEST CONDITIONS	MIN	TYP	MAX	UNIT
SWITCHING TIMES						
$t_{d(on)}$	Turn-on delay time	From $V_{IN} > V_{IN,IT+}$ to $V_{DS} < 320\text{V}$, $V_{BUS} = 400\text{V}$, L_{HB} current = 0A, 100V/ns		30	46	ns
	Turn-on current rise time + delay time	From $V_{IN} > V_{IN,IT+}$ to $V_{DS} < 320\text{V}$, $V_{BUS} = 400\text{V}$, L_{HB} current = 10A, 100V/ns		35	60	ns
$t_{vf(on)}$	Turn-on voltage falling time	From $V_{DS} < 320\text{V}$ to $V_{DS} < 80\text{V}$, $V_{BUS} = 400\text{V}$, L_{HB} current = 10A, 100V/ns	1	2.3	6	ns
	Turn-on slew rate	dv/dt when $V_{DS} = 200\text{V}$, $V_{BUS} = 400\text{V}$, L_{HB} current = 10A, 100V/ns	76	115	150	V/ns
	Pulse width distortion	slew-rate setting at 100V/ns			20	ns
	Minimum input pulse changing the output L-H-L	slew-rate setting at 100V/ns such that SW crosses 200V			50	ns
$t_{d(off)}$	Turn-off delay time at full speed	From $V_{IN} < 2.5\text{V}$ to $V_{DS} \geq 10\text{V}$, $V_{BUS} = 400\text{V}$, $I_L = 34\text{A}$, fastest or full turn-off speed.	12	17	35	ns
$t_{vr(off)}$	Turn-off voltage rise time at full speed	From $V_{DS} \geq 20\text{V}$ to $V_{DS} \geq 380\text{V}$, $V_{BUS} = 400\text{V}$, $I_L = 34\text{A}$, fastest or full turn-off speed.	3	4.5	10	ns
STARTUP TIMES						
T_{DRV_START}	Driver startup delay	From Driver supply crossing UVLO to switch turning on if IN is high.		35	65	μs
FAULT TIMES						
$t_{off(OC)}$	Overcurrent fault FET turn-off time, FET on before overcurrent	From $I_D \geq I_{T(OC)}$ to $V_{ds} > 10\text{V}$, $di/dt = 100\text{A}/\mu\text{s}$, in the fastest turn-off speed		370	480	ns
$t_{off(OC_ON)}$	Overcurrent total on time, turn-on into overcurrent.	From $V_{ds} \leq 10\text{V}$ to $V_{ds} \geq 10\text{V}$, turning on at 110% of OC level, at 100 V/ns turn-on slew rate and fastest turn-off speed.		420	580	ns
$t_{off_cur(SC_ON)}$	SC on time measured through drain current	From LS $I_{ds} > 50\text{A}$ to $I_{ds} < 50\text{A}$, at 100 V/ns turn-on slew rate in a half-bridge configuration.	100		500	ns
$t_{off_cur(SC)}$	SC response time with source current measurement	From LS $V_{ds} > 9\text{V}$ to LS $I_{ds} < 50\text{A}$, at 100 V/ns turn-on slew rate in a half-bridge configuration. .			350	ns
	Latched-Fault reset time	Time required to hold both gate driver input low to clear latched-fault	300	380	450	μs
ZERO-VOLTAGE DETECTION AND ZERO-CURRENT DETECTION TIMES						

6.6 Switching Characteristics (continued)

Unless otherwise noted: voltage, resistance, capacitance, and inductance are respect to GND/SRC; $-40^{\circ}\text{C} \leq T_J \leq 150^{\circ}\text{C}$; $V_{DD} = 12\text{V}$; $\overline{\text{FLT}}/\text{RDRV}$ resistances RDRV_{on} & RDRV_{off} are open

PARAMETER		TEST CONDITIONS	MIN	TYP	MAX	UNIT
	ZCD delay	Current crossing zero (low to high) to ZCD output pulse $di/dt = 0.03\text{A/ns}$	12	25	50	ns
	ZVD delay	In rising to ZVD output pulse. 100V/ns turn-on speed.	13	20	50	ns
$t_{\text{WD_ZVD}}$	ZVD pulse width	$V_{\text{bus}} = 10\text{V}$, $I_L = 5\text{A}$, measure ZVD pulse width	90	120	170	ns
	ZVD sensing time	Sensing time to fet turn on (100V/ns). $I_L=2\text{A}$		11	25	ns

7 Parameter Measurement Information

7.1 Switching Parameters

Figure 7-1 shows the circuit used to measure most switching parameters. The top device in this circuit is used to re-circulate the inductor current and functions in third-quadrant mode only. The bottom device is the active device that turns on to increase the inductor current to the desired test current. The bottom device is then turned off and on to create switching waveforms at a specific inductor current. Both the drain current (at the source) and the drain-source voltage is measured. Figure 7-2 shows the specific timing measurement. TI recommends to use the half-bridge as a double pulse tester. Excessive third-quadrant operation can overheat the top device.

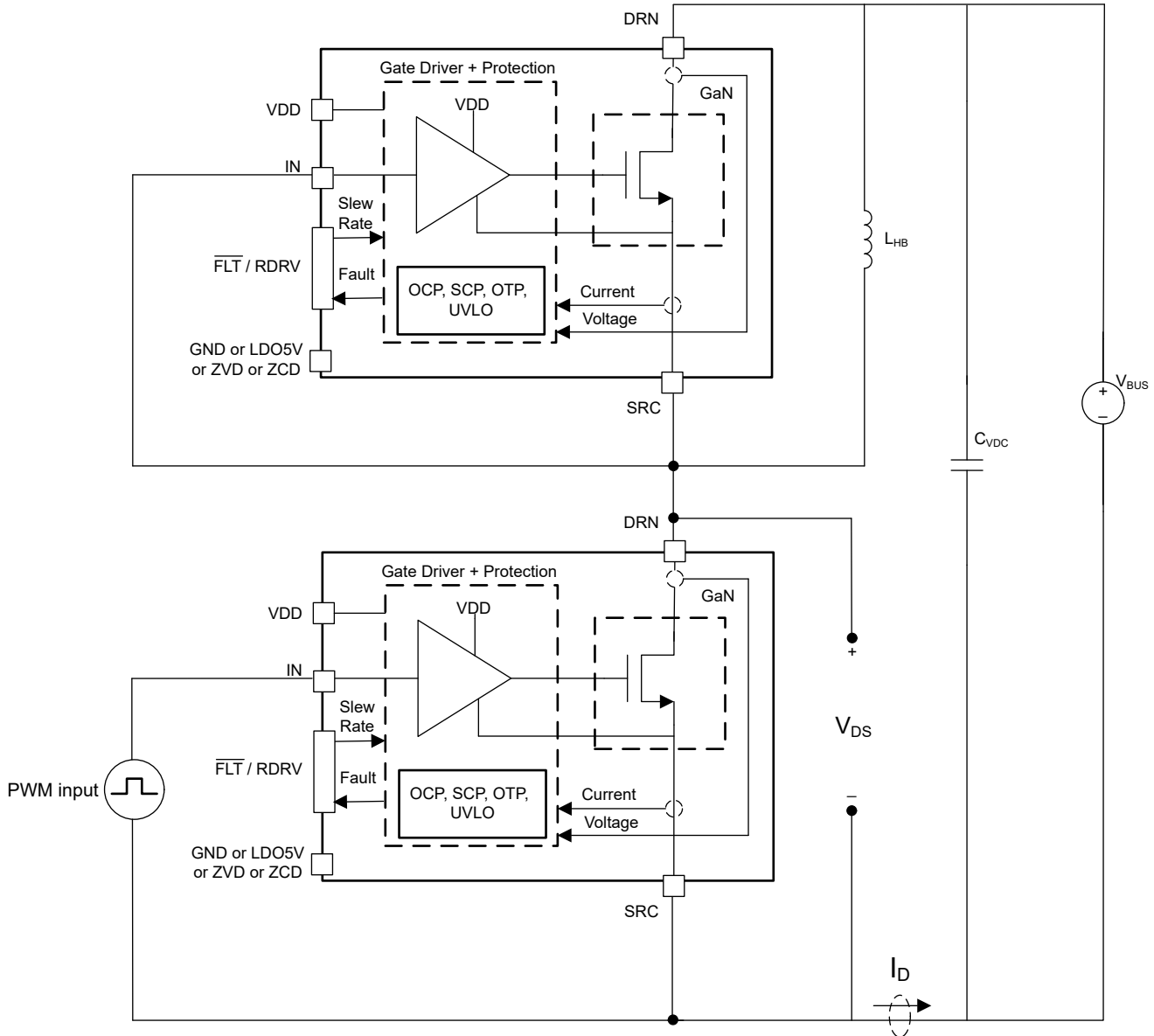

Figure 7-1. Circuit Used to Determine Switching Parameters

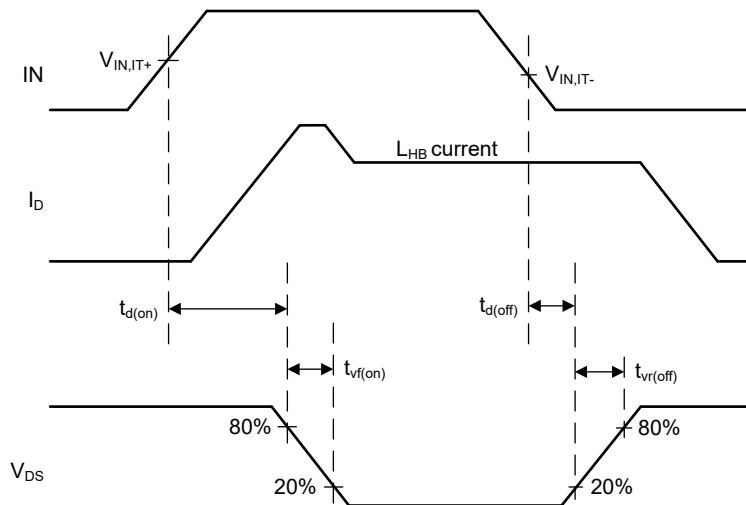

Figure 7-2. Measurement to Determine Propagation Delays and Slew Rates

ADVANCE INFORMATION

7.1.1 Turn-On Times

The turn-on transition has two timing components: turn-on delay time, and turn-on voltage fall time. The turn-on delay time is from when IN goes high to when the drain-source voltage falls 20% below the bus voltage. The turn-on voltage fall time is from when drain-source voltage falls 20% below the bus voltage to when the drain-source voltage falls 80% below the bus voltage. Note that the turn-on timing components are a function of the turn-on drive strength resistance RDRV_on connected to the $\overline{\text{FLT}}/\text{RDRV}$ pin.

7.1.2 Turn-Off Times

The turn-off transition has two timing components: turn-off delay time, and turn-off voltage rise time. The turn-off delay time is from when IN goes low to when the drain-source voltage rises to 20% of the bus voltage. The turn-off voltage rise time is from when the drain-source voltage rises from 20% of the bus voltage to when the drain-source voltage to 80% of the bus voltage. Note that the turn-off timing components are dependent on the L_{HB} load current, however LMG365xR025 also features the ability to limit turn-off drive strength. When the drain-to-source current is sufficiently high and the turn-off drive strength is limited, the timing components become dependent on the programming resistors RDRV_on, RDRV_off, and capacitance CDRV_off connected to the $\overline{\text{FLT}}/\text{RDRV}$ pin.

7.1.3 Drain-Source Turn-On and Turn-off Slew Rate

The drain-source turn-on and turn-off slew rate is measured on V_{DS} around the midpoint of the bus voltage, with units in volts per nanosecond. The resistors RDRV_on, RDRV_off, and capacitance CDRV_off connected to the $\overline{\text{FLT}}/\text{RDRV}$ pin is used to program the turn-on slew rate and limit the turn-off slew rate.

7.1.4 Zero-Voltage Detection Times (LMG3656R025 only)

Figure 7-3 defines the switching timings related to the zero-voltage detection (ZVD) block, and the device's drain-to-source voltage, IN pin signal, and ZVD output signals are demonstrated. When the device achieves zero-voltage switching (ZVS), the ZVD pin outputs a pulse-signal with width $T_{\text{WD_ZVD}}$, and the delay time in between IN pin's rising edge and ZVD pulse's rising edge is defined as $T_{\text{DL_ZVD}}$. A certain third quadrant conduction time is required to allow the device detecting a zero-voltage switching, and $T_{\text{3rd_ZVD}}$ indicates this timing. See the Section 8.3.8 section for more information about the ZVD timing parameters.

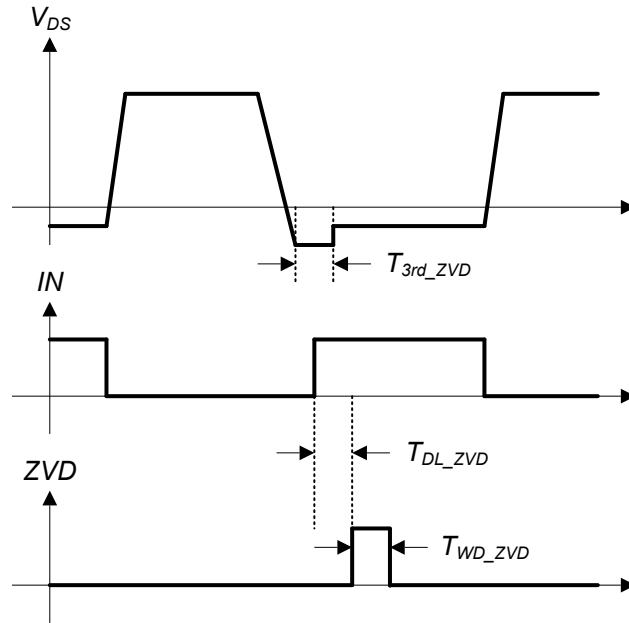

Figure 7-3. ZVD Timing Specifications

8 Detailed Description

8.1 Overview

The LMG365xR025 is a high-performance power GaN device with integrated gate driver. The GaN device offers zero reverse recovery and ultra-low output capacitance, which enables high efficiency in bridge-based topologies.

The integrated driver ensures the device stays off for high drain slew rates. The integrated driver protects the GaN device from overcurrent, short-circuit, overtemperature, VDD undervoltage, and a high-impedance RDRV pin. The LMG3656R025 has a zero-voltage detection (ZVD) feature that outputs a pulse signal on the ZVD pin when zero-voltage switching (ZVS) is detected. The LMG3657R025 includes the zero-current detection (ZCD) feature which provides a pulse output from the ZCD pin when a positive drain-to-source current is detected.

Unlike Si MOSFETs, GaN devices do not have a p-n junction from source to drain and thus have no reverse recovery charge. However, GaN devices still conduct from source to drain similar to a p-n junction body diode, but with higher voltage drop and higher conduction loss. Therefore, source-to-drain conduction time must be minimized while the LMG365xR025 GaN FET is turned off.

8.2 Functional Block Diagram

8.2.1 LMG3650R025 Functional Block Diagram

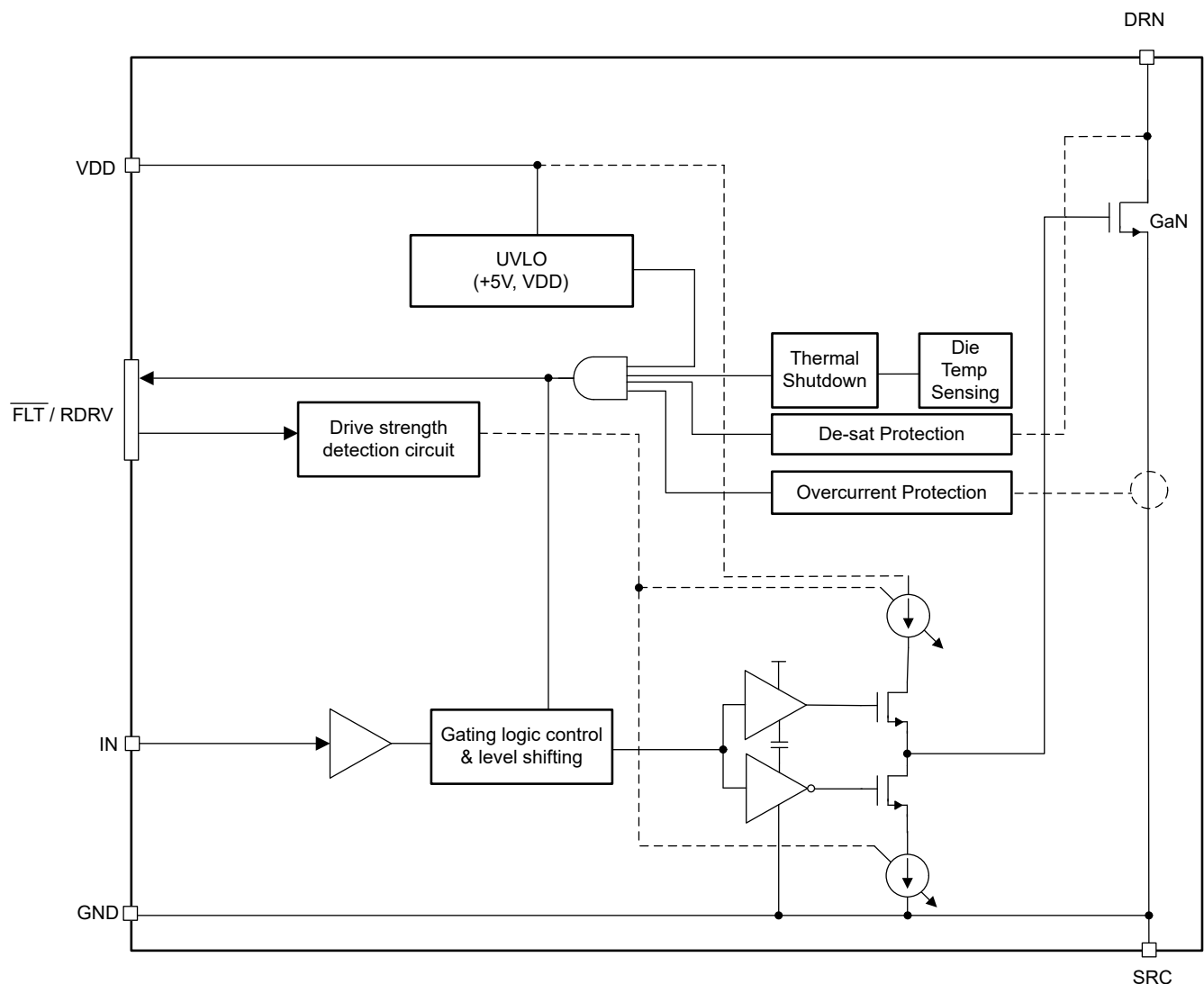

8.2.2 LMG3651R025 Functional Block Diagram

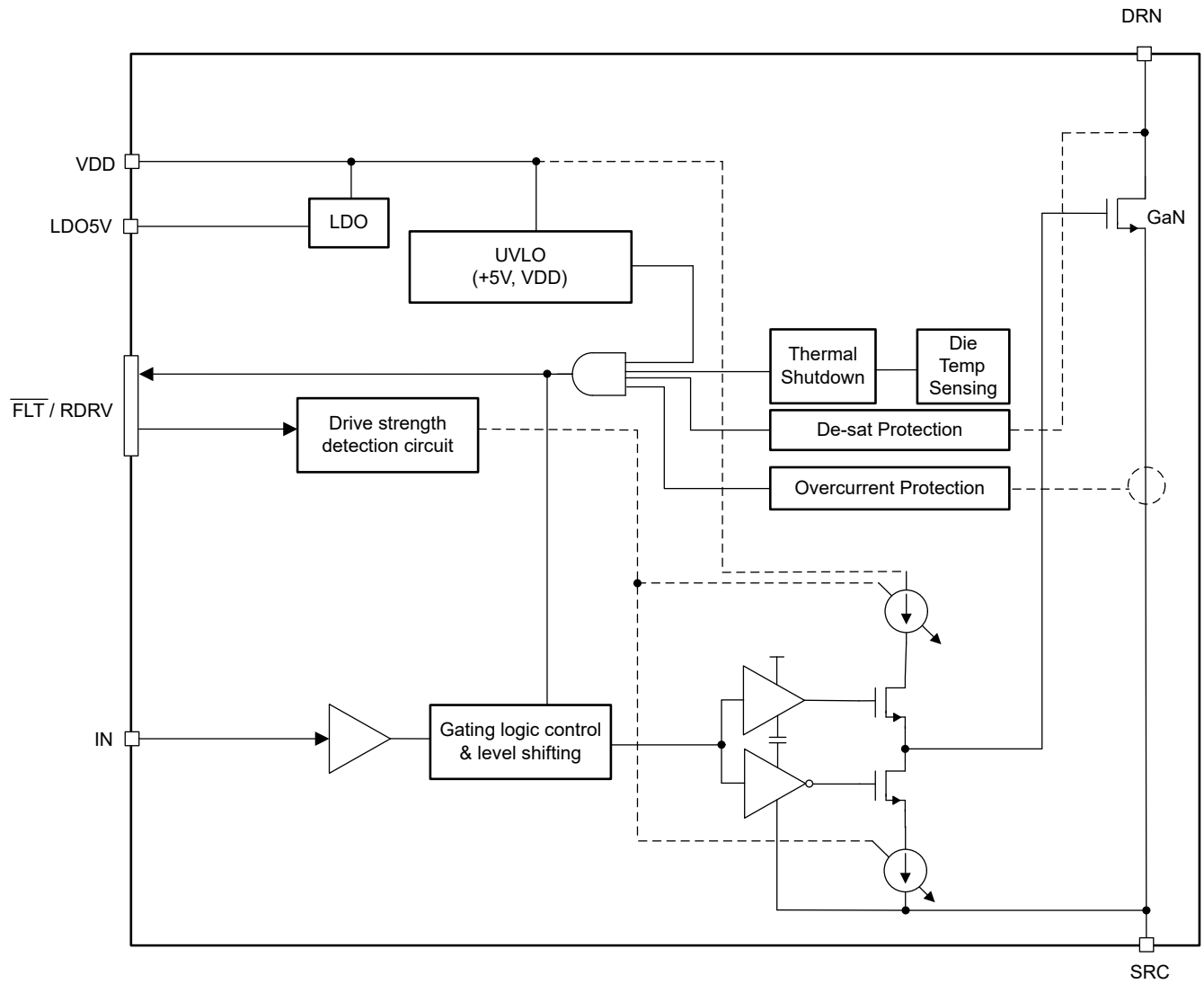

ADVANCE INFORMATION

8.2.3 LMG3656R025 Functional Block Diagram

ADVANCE INFORMATION

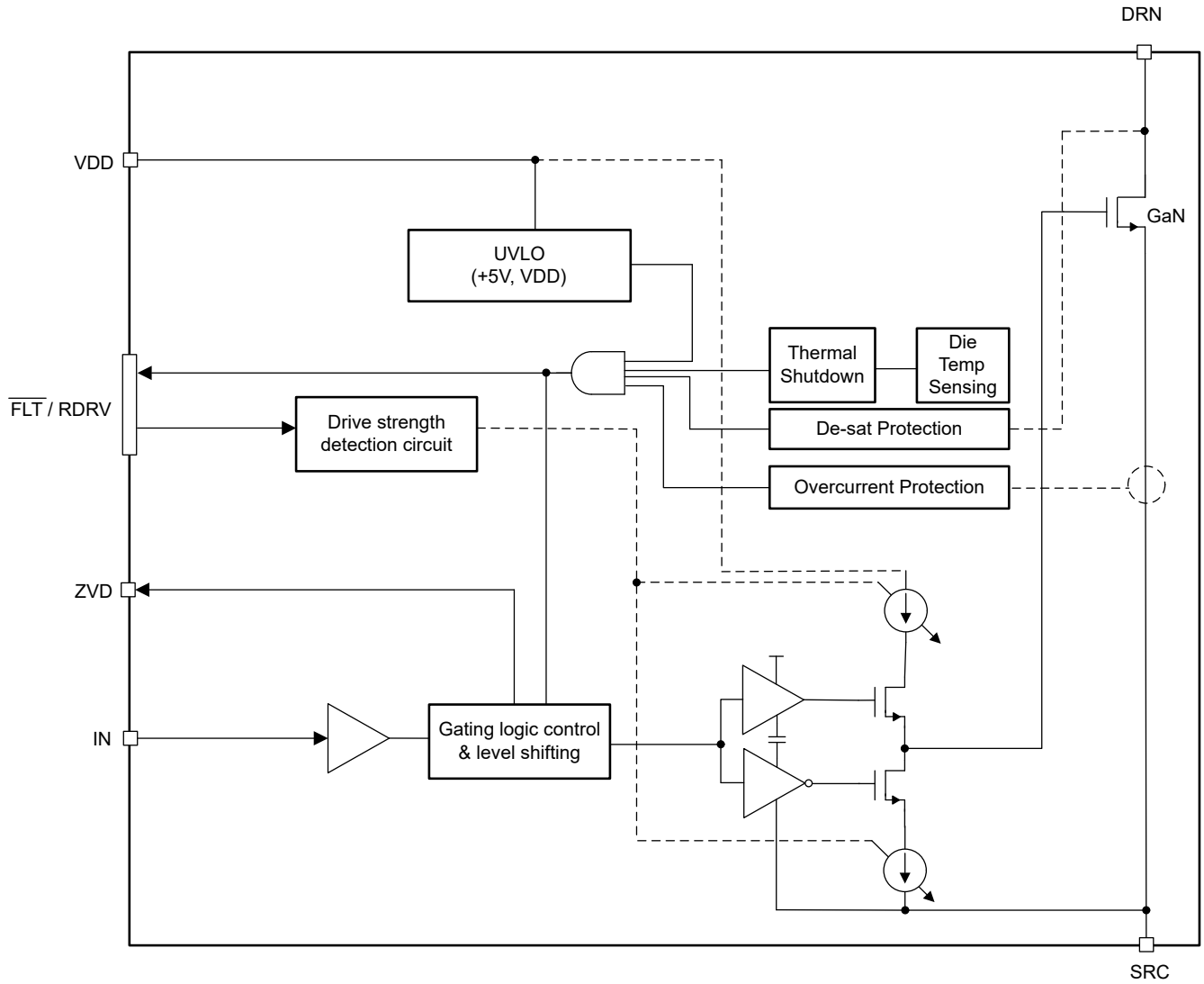

8.2.4 LMG3657R025 Functional Block Diagram

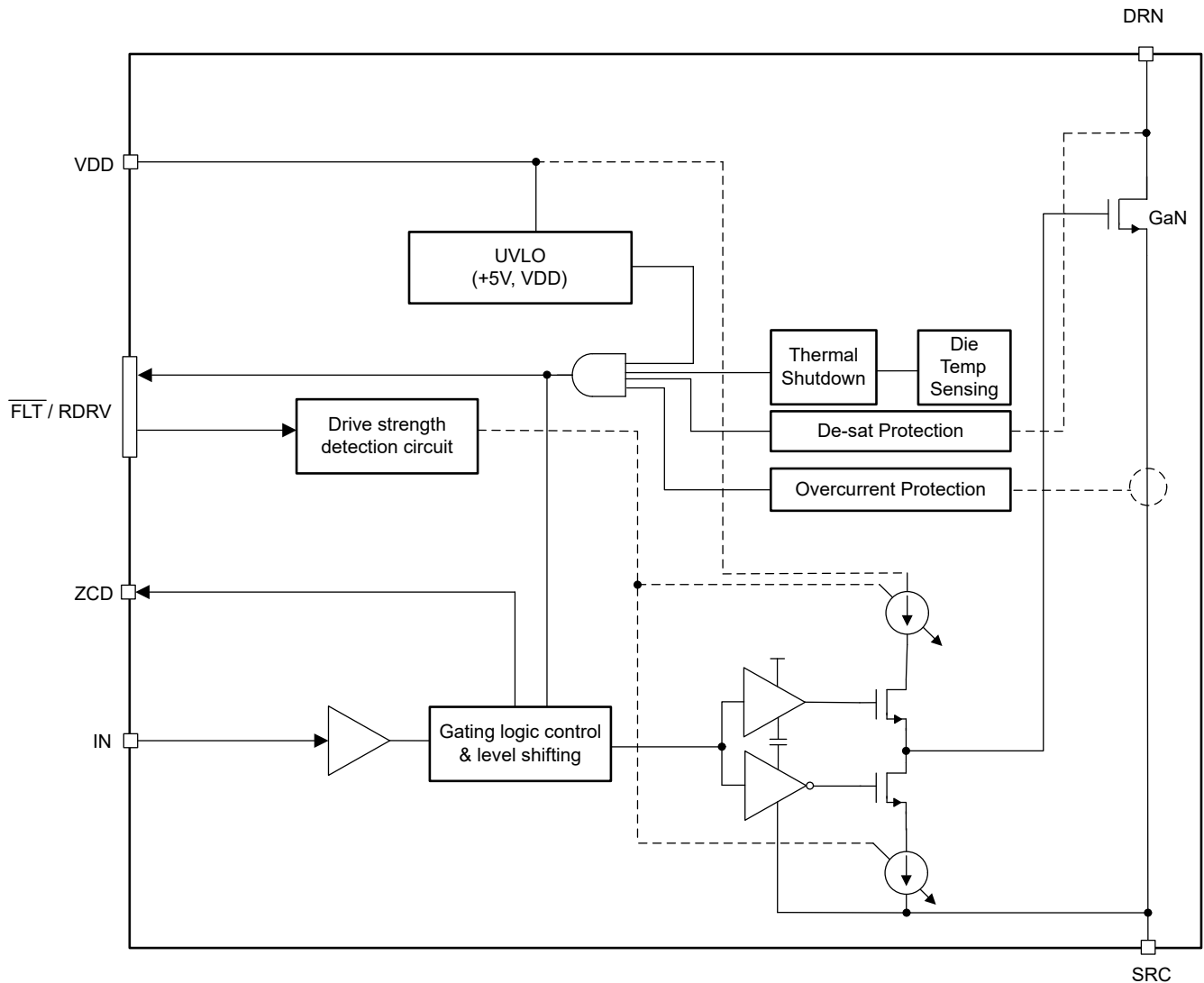

ADVANCE INFORMATION

8.3 Feature Description

8.3.1 Drive Strength Adjustment

The LMG365xR025 allows users to adjust the drive strength of the device and obtain a desired slew rate, which provides flexibility when optimizing switching losses and minimizing EMI. The typical value of turn-on slew rate and the maximum value of turn-off slew rate can be independently controlled by connecting the resistors and capacitor as shown in the [Figure 8-1](#). The resistance and capacitance on $\overline{\text{FLT}}/\text{RDRV}$ pin is sensed once at power-up. To do so, the device forces a step-function from 0V to 1.2V on the external $\text{RDRV}_{\text{on}}\text{-RDRV}_{\text{off}}\text{-CDRV}_{\text{off}}$ network and measures the resulting current waveform. The DC measurement determines the turn-on slew rate setting, which is programmed by the resistance RDRV_{on} . The AC measurement dependent on $\text{RDRV}_{\text{on}}\text{-RDRV}_{\text{off}}\text{-CDRV}_{\text{off}}$ determines the turn-off slew rate setting, which is dependent on the magnitude of the drain-to-source current charging the output capacitance but can be limited to a maximum value programmed by the resistance RDRV_{off} and capacitance CDRV_{off} , connected in parallel to RDRV_{on} . [Table 8-1](#) shows the recommended typical resistances and capacitance programming values at each slew rate setting.

The slew rate settings are determined one time at power up, then the $\overline{\text{FLT}}/\text{RDRV}$ pin is used as a push-pull 5V digital output for fault monitoring, as described in [Fault Reporting](#). If RDRV_{off} and CDRV_{off} are not used, the device turns-off at full-speed and the turn-off slew rate is strictly determined by the C_{oss} and the load current. If

RDRV_{on} is not used, the device defaults to the 100V/ns slew rate setting. Using slower turn-on settings results in higher E_{on} losses, and slower turn-off settings results in higher E_{off} losses.

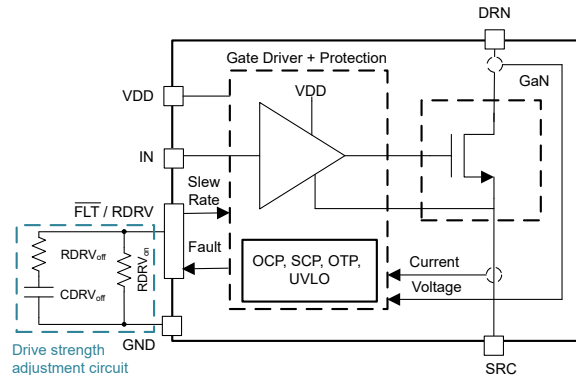

Figure 8-1. Drive Strength Adjustment Circuit

Table 8-1. Recommended Typical Programming Resistance (kΩ) and Capacitance (pF) for Adjusting Slew Rates

TYPICAL TURN-ON SLEW RATE (V/ns)	MAXIMUM TURN-OFF SLEW RATE (V/ns)								
	RDRV _{on}	10		20		40		No limit ⁽¹⁾	
		RDRV _{off}	CDRV _{off}	RDRV _{off}	CDRV _{off}	RDRV _{off}	CDRV _{off}	RDRV _{off}	CDRV _{off}
10	29.4	2	680	4.87	270	9.09	150	high impedance ⁽²⁾	
20	35.7	2	680	4.75	270	8.66	150		
40	43.2	2	680	4.64	270	8.25	150		
60	53.6	2	680	4.64	270	8.06	150		
80	69.8	2	680	4.53	270	7.68	150		
100	> 400 ⁽²⁾	2	680	4.22	270	6.98	180		

(1) Fully dependent on the magnitude of the drain-to-source current charging the output capacitance

(2) Open-circuit connection for programming resistances is acceptable

For example, setting RDRV_{on} = 53.6kΩ, RDRV_{off} = 4.64kΩ and CDRV_{off} = 270pF results in turn-on slew rate of 60V/ns and turn-off slew rate is limited to a maximum of 20V/ns.

8.3.2 VDD Supply

VDD is the input supply for the internal circuits. Wide voltage ranges from 9V to 26V are supported on VDD pin.

8.3.3 Overcurrent and Short-Circuit Protection

There are two types of current faults which can be detected by the driver: overcurrent fault and short-circuit fault.

The overcurrent protection (OCP) circuit monitors drain current and compares that current signal with an internally set limit I_{T(OC)}. Upon detection of the overcurrent, the LMG365xR025 performs cycle-by-cycle protection as shown in Figure 8-2. In this mode, the GaN device is shut off when the drain current crosses the I_{T(OC)} plus a delay t_{off(OC)}, but the overcurrent signal clears after the IN pin signal goes low. In the next cycle, the GaN device can turn on as normal. The cycle-by-cycle function can be used in cases where steady-state operation current is below the OCP level but transient response can still reach current limit, while the circuit operation cannot be paused. The cycle-by-cycle function also prevents the GaN device from overheating by overcurrent induced conduction losses.

The short-circuit protection is based on desaturation (de-sat) detection, which monitors the drain-source voltage V_{DS} and compares the voltage with an internally set limit V_{T(Idsat)}. If the OC occurs before the de-sat, the V_{DS} is below the threshold, then OC is triggered, else de-sat is triggered as shown in Figure 8-3. Saturation can be damaging for the GaN to continue to operate in that condition. Therefore, if a de-sat is detected, the GaN device is turned off with an intentionally slowed driver so that a lower overshoot voltage and ringing can be achieved

during the turn-off event. This fast response circuit helps protect the GaN device even under a hard short-circuit condition. In this protection, the GaN device is shut off and held off until the fault is reset by either holding the IN pin low for a period of time defined in the [Specifications](#) or removing power from VDD.

For safety considerations, OCP allows cycle-by-cycle operation while de-sat latches the device until reset. Both faults are reported on the $\overline{\text{FLT/RDRV}}$ pin.

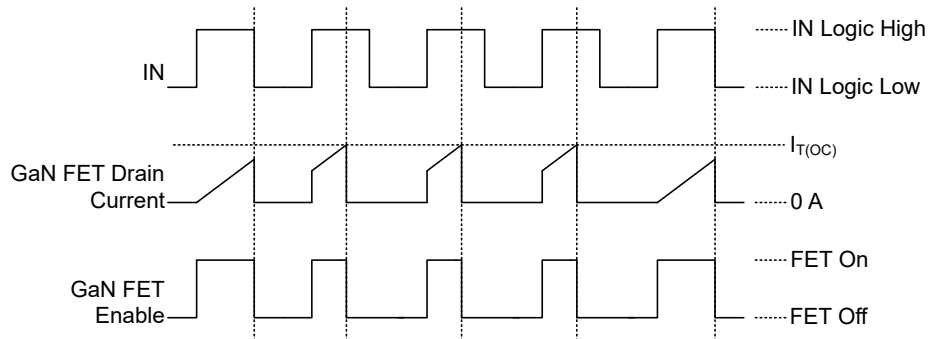

Figure 8-2. Cycle-by-Cycle Overcurrent Protection Operation

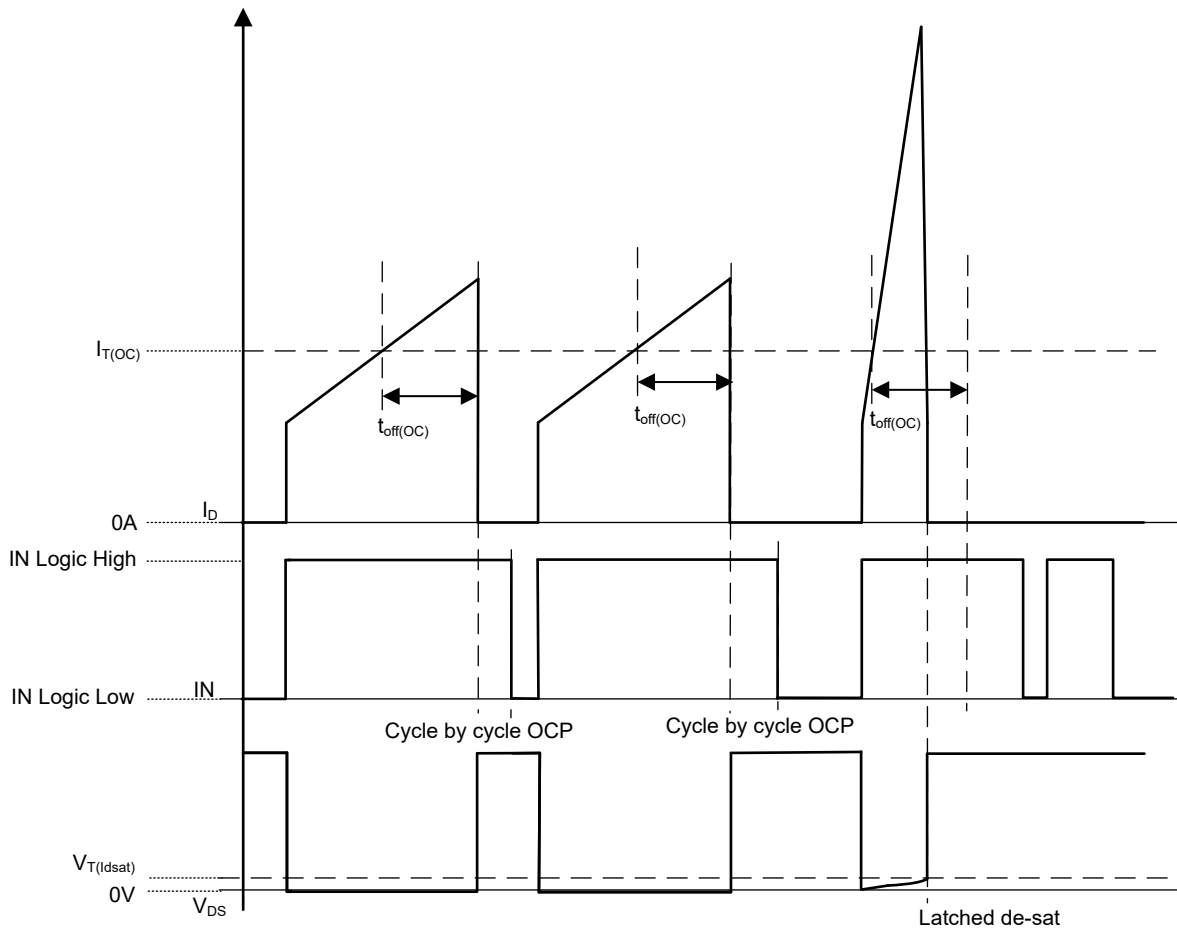

Figure 8-3. Overcurrent Detection vs Desaturation Detection

8.3.4 Overtemperature Protection

The overtemperature protection holds off the GaN power FET if the LMG365xR025 temperature is above the overtemperature protection threshold. The overtemperature protection hysteresis avoids erratic thermal cycling.

An overtemperature fault is reported on the $\overline{\text{FLT}}/\text{RDRV}$ pin when the overtemperature protection is asserted. $\overline{\text{FLT}}/\text{RDRV}$ de-asserts and the device automatically returns to normal operation after the device temperature fall below the negative-going trip point.

8.3.5 UVLO Protection

The LMG365xR025 supports a wide range of V_{DD} voltages. However, when the V_{DD} voltage is below V_{DD} UVLO threshold, the GaN device stops switching and is held off. The V_{DD} UVLO voltage hysteresis prevents on-off chatter near the UVLO voltage trip point. The $\overline{\text{FLT}}/\text{RDRV}$ pin is pulled low as an indication of UVLO.

8.3.6 Fault Reporting

All faults are reported on the $\overline{\text{FLT}}/\text{RDRV}$ pin, which serves as both an input and output pin.

The $\overline{\text{FLT}}/\text{RDRV}$ is configured as an input only at the time of powerup to adjust the drive-strength, as described in [Drive Strength Adjustment](#).

The $\overline{\text{FLT}}/\text{RDRV}$ then used as an active low digital output, indicating the fault status thereafter. The pin is a push-pull 5V digital output which goes high when all faults have cleared, which means that there is additional quiescent current through R1 when the pin is forced high.

Depending on the input threshold levels for the external digital receiver connected to the fault pin, the 1.2V which is forced on this pin at power-up could be interpolated as either high or low. For this reason, it is recommended that the receiver has higher thresholds such as those common for CMOS-compatible inputs and not use TTL compatible inputs. If the input thresholds are lower, the 1.2V at power-up can be interpreted as a "high" and therefore showing that the device is not faulted when still powering up.

8.3.7 Auxiliary LDO (LMG3651R025 Only)

There is a 5V voltage regulator inside the part used to supply external loads, such as digital isolators for the high-side drive signal. The digital outputs of the part use this rail as their supply. No capacitor is required for stability, but transient response is poor if no external capacitor is provided. If the application uses this rail to supply external circuits, TI recommends to have a capacitor of at least 0.1 μF for improved transient response. A larger capacitor can be used for further transient response improvement. The decoupling capacitor used here must be a low-ESR ceramic type. Capacitances above 0.47 μF will slow down the start-up time of the LMG365xR025 due to the ramp-up time of the 5V rail.

8.3.8 Zero-Voltage Detection (ZVD) (LMG3656R025 Only)

The zero-voltage switching (ZVS) converters are widely used to improve the power converter's efficiency. However, in those soft-switching topologies like LLC and triangular current mode (TCM) totem pole PFC, the device can lose ZVS depending on the load condition, inductor, magnetic parameters and control techniques, which affects the system efficiency. To insure ZVS, certain design margins or additional circuits are needed which sacrifices the converter performance and adds components.

To simplify the system design for soft-switching converters, LMG3656R025 part integrates a zero-voltage detection (ZVD) circuit that provides a digital feedback signal to indicate if the device has achieved ZVS in the current switching cycle. The circuit diagram is shown in Figure 8-4. When the IN pin signal goes high, the logic circuit checks if the device V_{DS} has reached below 0V to determine whether the device has achieved zero voltage switching in this switching cycle. Once a ZVS is identified, a pulse-output with a width of T_{WD_ZVD} will be sent out from the ZVD pin after a delay time of T_{DL_ZVD} as indicated in Figure 7-3. Note a certain third quadrant conduction time is required to allow the device detecting a zero-voltage switching, and T_{3rd_ZVD} is a function of the gate driver strength.

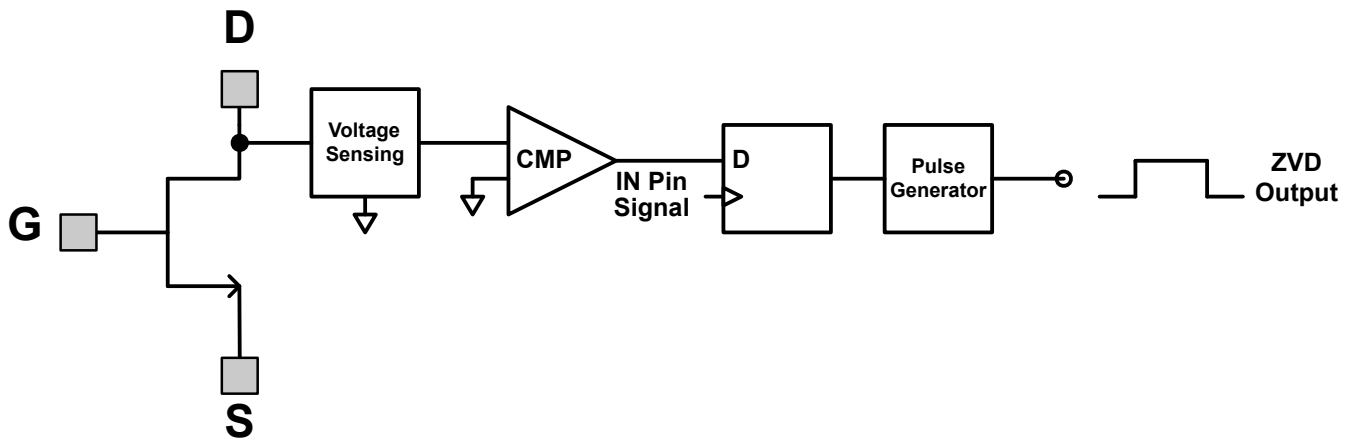

Figure 8-4. Circuit Diagram for Zero-Voltage Detection Circuit Block Diagram

The timings of the ZVD output corresponding to a continuous conduction mode Buck converter is shown in Figure 8-5, and the purpose is to demonstrate how ZVD function works in both hard-switching and soft-switching conditions. The load current going out of the switch node is defined as positive. In CCM buck operation, the high-side the hard-switching device while the low-side device can achieve zero-voltage switching with a proper dead-time settings. In the first switching cycle when low-side GaN IN pin rises, the switch-node voltage V_{DS} has dropped below zero and stays in third quadrant conduction for a period of T_1 . Since this third quadrant conduction time T_1 is larger than the detection time T_{3rd_ZVD} specified in electrical characteristic table, a zero-voltage switching is identified and the ZVD pin outputs a pulse signal to indicate that, and the pulse width of the ZVD pulse is also defined in the electrical characteristic table as T_{WD} . In the second switching cycle, the device is turned on earlier, and the third quadrant conduction time T_2 is less than T_{3rd_ZVD} . In this case, the ZVD signal stays low though the device has achieved ZVS. In the third switching cycle, the IN pin signal is advanced even earlier, and the device is in partial hard-switching. Accordingly, the ZVD output stays low in this case. Note the high side ZVD output stays low in this CCM buck operation as it always has hard-switching.

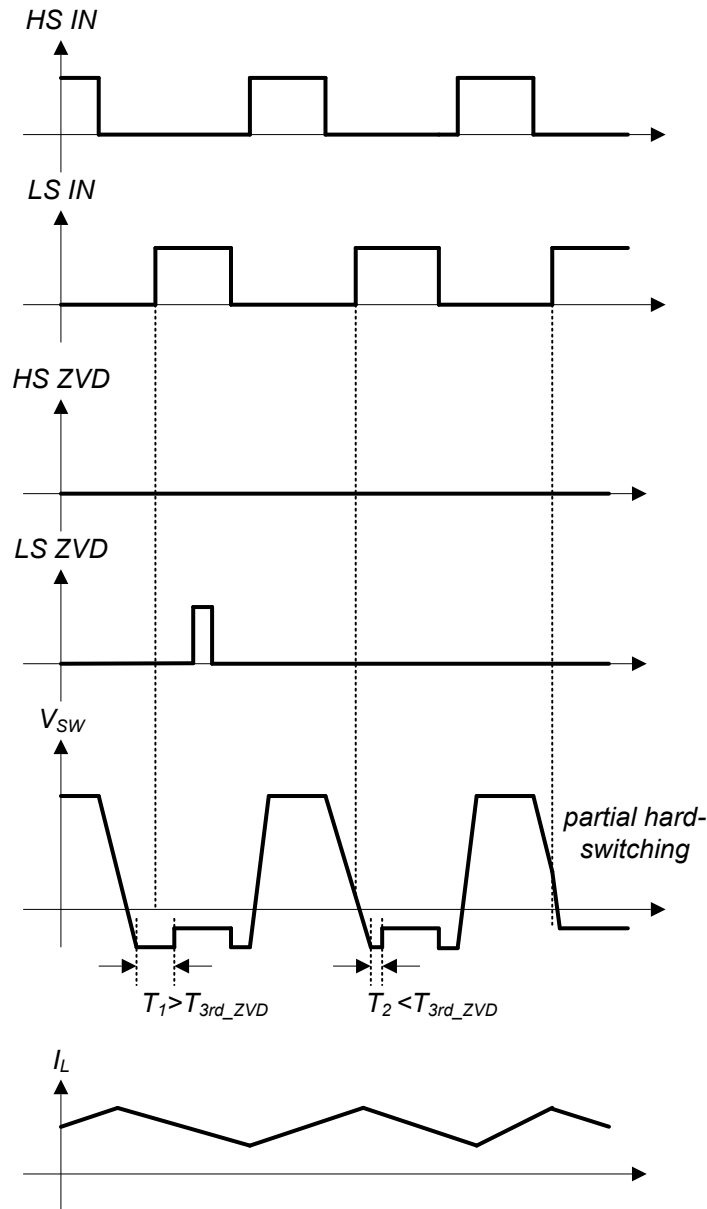

Figure 8-5. ZVD Function in a CCM Buck Converter

The ZVD function can facilitate the control in soft-switching topology, to illustrate it, the ZVD waveforms in a TCM totem pole PFC is shown in [Figure 8-6](#). In this diagram, the positive cycle is considered with $V_{IN} > 0.5 V_{OUT}$, and the load current going into the switch node is defined as positive. In the first switching cycle, the load current builds enough negative current, and the low-side device achieves ZVS with a clear third quadrant conduction time beyond T_{3rd_DET} . Therefore, the ZVD outputs a pulse signal and provide the ZVS information back. The ZVD pulses are missing in the next two switching cycles because the third quadrant conduction time becomes shorter in second cycle and the device actual loses ZVS in the third cycle.

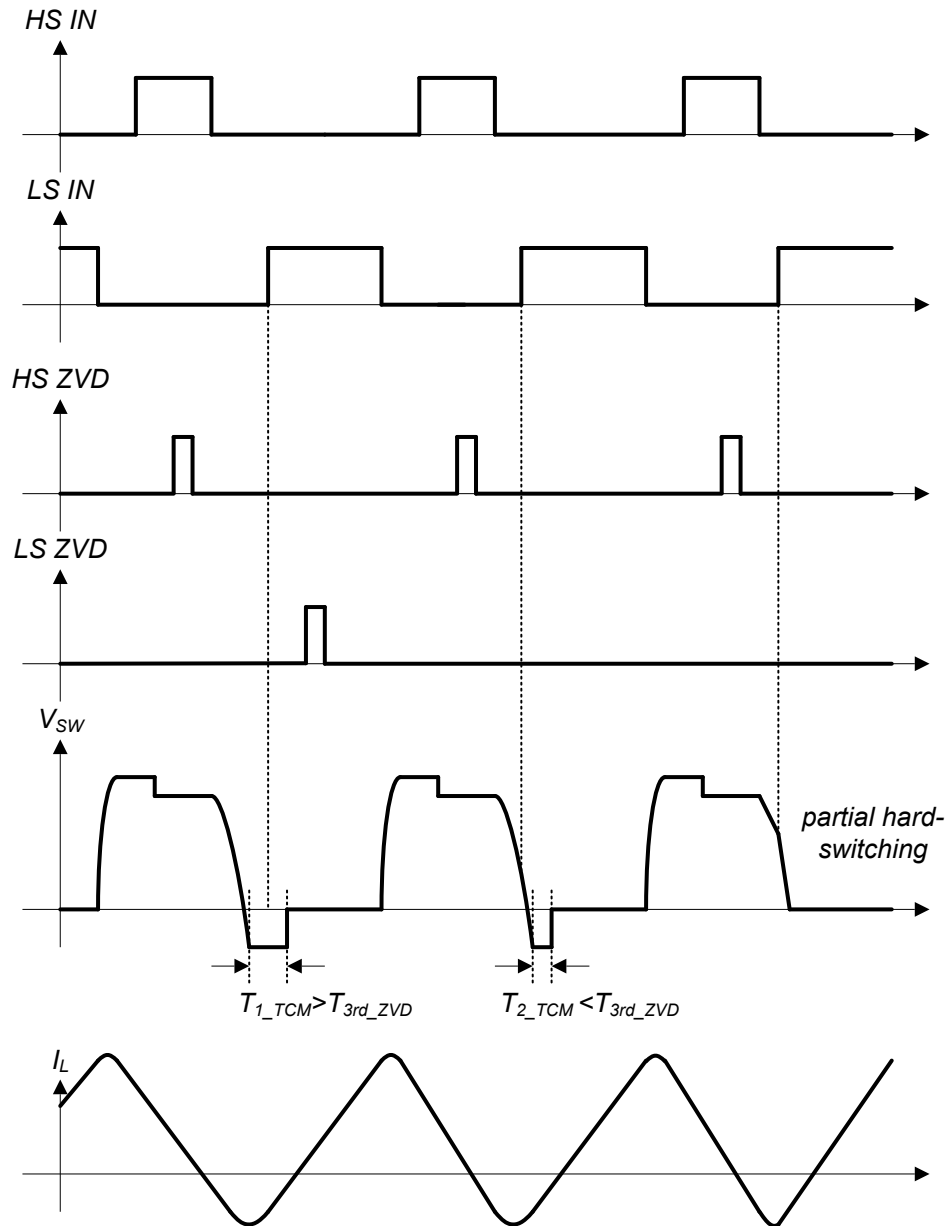

Figure 8-6. ZVD Function in a TCM TP PFC Converter

8.3.9 Zero-Current Detection (ZCD) (LMG3657R025 Only)

GaN FET is usually used for high frequency soft-switching and the detection of FET current zero-crossing is needed for system control. LMG3657R025 integrates a zero current detection (ZCD) circuit that provides a digital feedback signal to indicate the when the drain-to-source current is positive. When the IN pin signal goes high, the ZCD circuit includes a blanking time t_{ZCD_Blank} , to prevent nuisance ZCD triggering during the turn-on transient. Following the blanking period, the ZCD circuit monitors the drain-to-source current. If the current is negative, a pulse-output with a width of t_{WD_ZVD} is set on the ZCD pin after detecting the zero-crossing point, with a delay time of t_{zc_Det} . If the current is positive, the pulse output is set on the ZCD pin immediately, as indicated in the timing diagrams below.

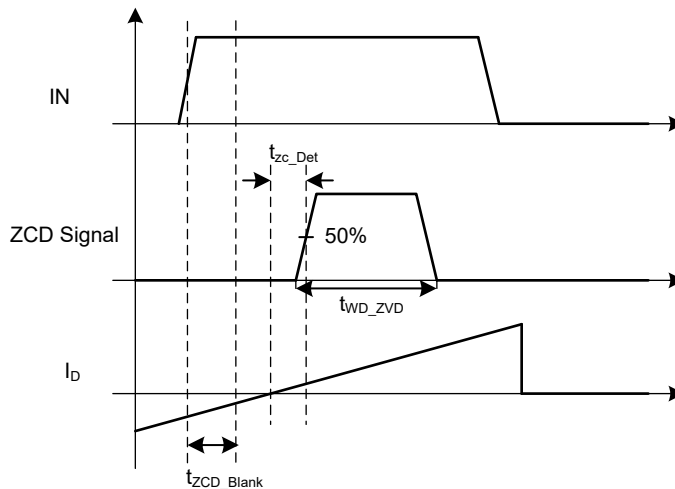

Figure 8-7. ZCD Timing Diagram When FET Turns ON Into Negative Current

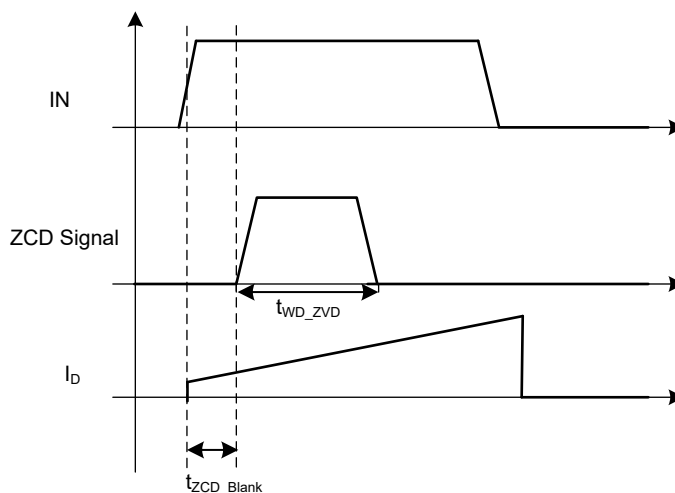

Figure 8-8. ZCD Timing Diagram When FET Turns ON Into Positive Current

8.4 Device Functional Modes

The device has one mode of operation that applies when operated within the Recommended Operating Conditions.

9 Application and Implementation

Note

Information in the following applications sections is not part of the TI component specification, and TI does not warrant its accuracy or completeness. TI's customers are responsible for determining suitability of components for their purposes, as well as validating and testing their design implementation to confirm system functionality.

9.1 Application Information

The LMG365xR025 is a power IC targeting hard-switching and soft-switching applications operating up to 480V bus voltages. GaN devices offer zero reverse-recovery charge enabling high-frequency, hard-switching in applications like the totem-pole PFC. Low Q_{oss} of GaN devices also benefits soft-switching converters, such as the LLC and phase-shifted full-bridge configurations. As half-bridge configurations are the foundation of the two mentioned applications and many others, this section describes how to use the LMG365xR025 in a half-bridge configuration.

(1)

9.2 Typical Application

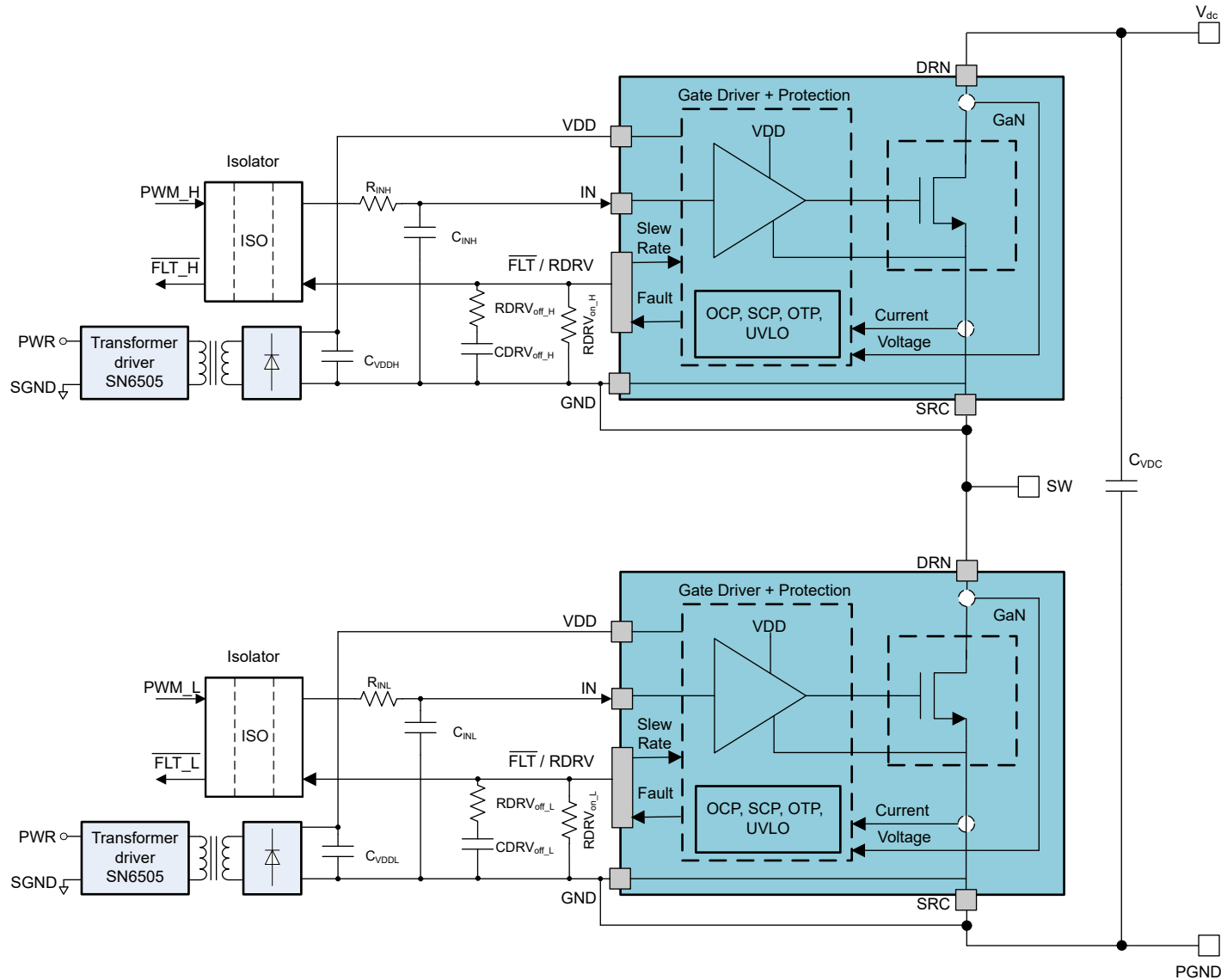

Figure 9-1. LMG3650R025 Typical Half-Bridge Application With Isolated Power Supply

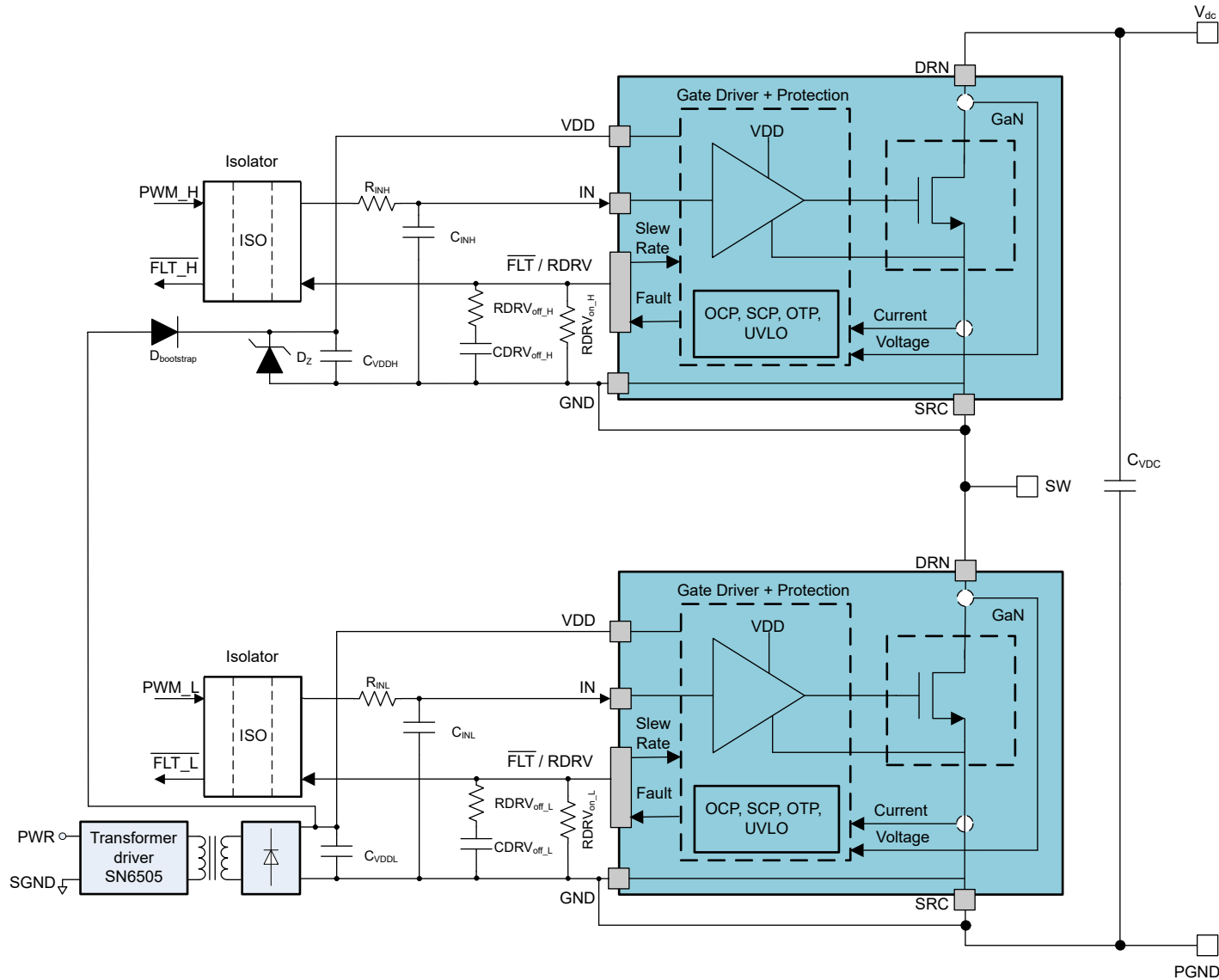

Figure 9-4. LMG3650R025 Typical Half-Bridge Application With Bootstrap

ADVANCE INFORMATION

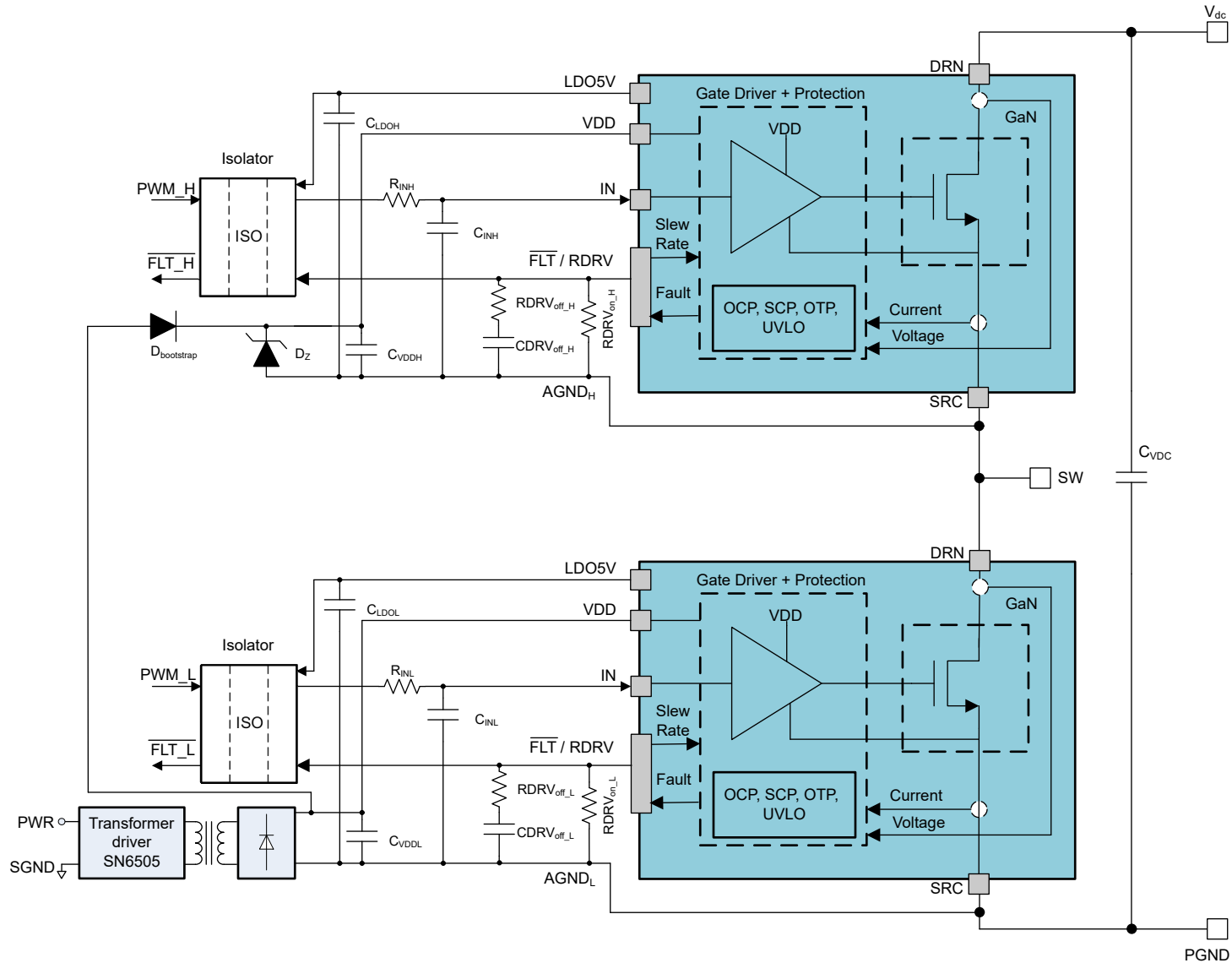

Figure 9-5. LMG3651R025 Typical Half-Bridge Application With Bootstrap

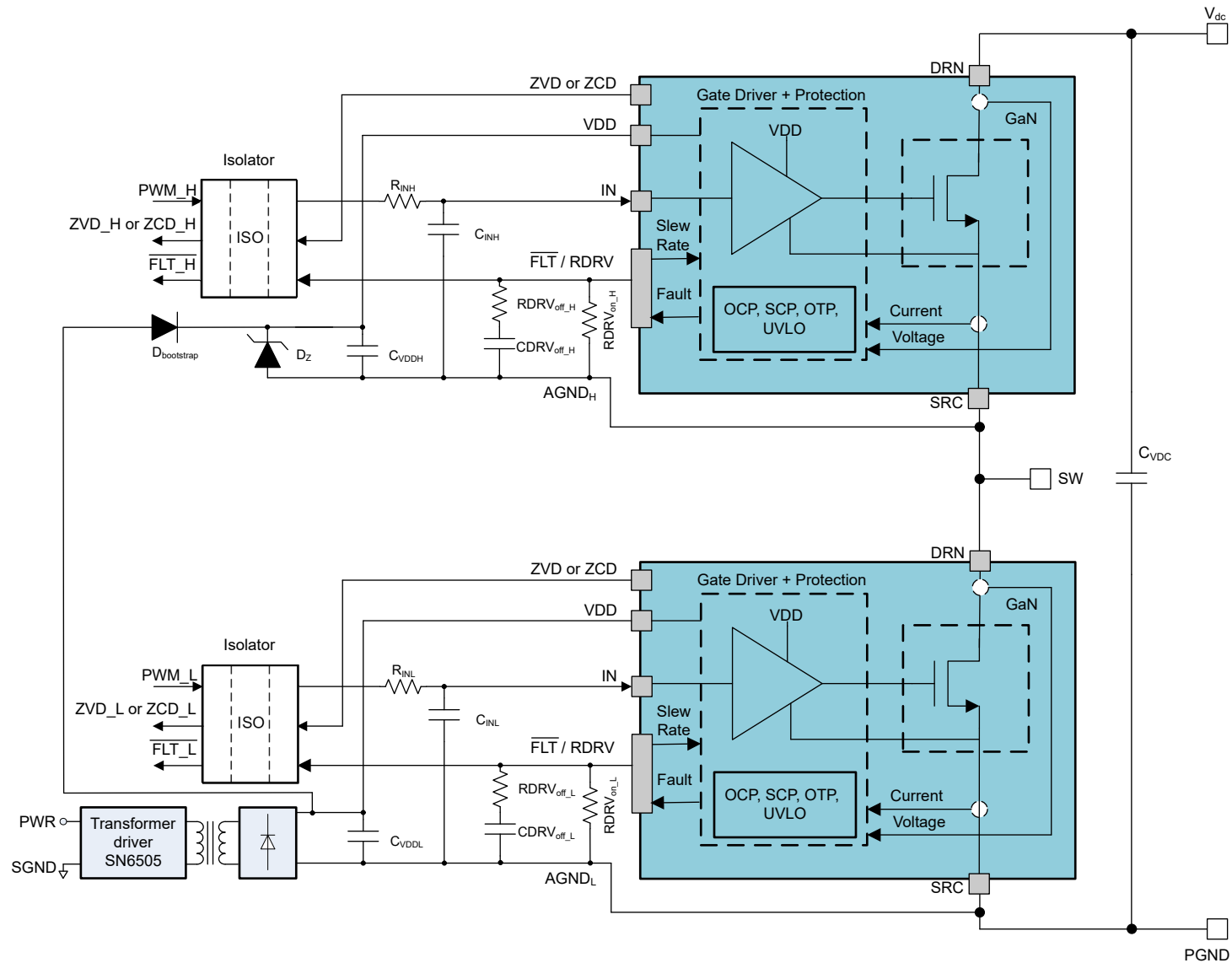

Figure 9-6. LMG3656R025 or LMG3657R025 Typical Half-Bridge Application With Bootstrap

ADVANCE INFORMATION

9.2.1 Design Requirements

This design example is for a hard-switched boost converter which is representative of PFC applications. [Design Parameters](#) shows the system parameters for this design.

Table 9-1. Design Parameters

PARAMETER	VALUE
Input voltage	200VDC
Output voltage	400VDC
Input (inductor) current	20A
Switching frequency	100kHz

9.2.2 Detailed Design Procedure

In high-voltage power converters, circuit design and PCB layout are essential for high-performance power converters. As designing a power converter is out of the scope of this document, this data sheet describes how to build well-behaved half-bridge configurations with the LMG365xR025.

9.2.2.1 Slew Rate Selection

The slew rate of LMG365xR025 can be adjusted between approximately 10 V/ns and 100V/ns by connecting drive strength adjustment circuit. Refer to [Drive Strength Adjustment](#) for the details.

The slew rate affects GaN device performance in terms of:

- Switching loss
- Voltage overshoot
- Noise coupling
- EMI emission

Generally, high slew rates provide low switching loss, but high slew rates can also create higher voltage overshoot, noise coupling, and EMI emissions. Following the design recommendations in this data sheet helps mitigate the challenges caused by a high slew rate. The LMG365xR025 offers circuit designers the flexibility to select the proper slew rate for the best performance of their applications.

9.2.2.2 Signal Level-Shifting

In half-bridges, high-voltage level shifters or digital isolators must be used to provide isolation for signal paths between the high-side device and control circuit. Using an isolator is optional for the low-side device. However, using an isolator equalizes the propagation delays between the high-side and low-side signal paths, and provides the ability to use different grounds for the GaN device and the controller. If an isolator is not used on the low-side device, the control ground and the power ground must be connected at the device and nowhere else on the board. For more information, see [Layout Guidelines](#). With fast-switching devices, common ground inductance can easily cause noise issues without the use of an isolator.

Choosing a digital isolator for level-shifting is important for improvement of noise immunity. As GaN device can easily create high dv/dt , $> 50V/ns$, in hard-switching applications, TI highly recommends to use isolators with high common-mode transient immunity (CMTI) and low barrier capacitance. Isolators with low CMTI can easily generate false signals, which could cause shoot-through. The barrier capacitance is part of the isolation capacitance between the signal ground and power ground, which is in direct proportion to the common mode current and EMI emission generated during the switching. Additionally, TI strongly encourages to select isolators which are not edge-triggered. In an edge-triggered isolator, a high dv/dt event can cause the isolator to flip states and cause circuit malfunction.

Generally, ON/OFF keyed isolators with default output low are preferred. Default low state ensures the system will not shoot-through when starting up or recovering from fault events. As a high CMTI event would only cause a very short (a few nanoseconds) false pulse, TI recommends a low pass filter, like 300Ω and 22pF R-C filter, to be placed at the driver input to filter out these false pulses.

9.3 Power Supply Recommendations

The LMG365xR025 only requires an unregulated VDD power supply from 9V to 26V. The low-side supply can be obtained from the local controller supply. The supply of the high-side device must come from an isolated supply or a bootstrap supply.

9.3.1 Using an Isolated Power Supply

Using an isolated power supply to power the high-side device has the advantage that it works regardless of continued power-stage switching or duty cycle. Using an isolated power supply can also power the high-side device before power-stage switching begins for a smooth start-up.

The isolated supply can be obtained with a push-pull converter, a flyback converter, a FlyBuck™ converter, or an isolated power module. When using an unregulated supply, the input of LMG365xR025 must not exceed the maximum supply voltage. A 26V TVS diode can be used to clamp the VDD voltage of LMG365xR025 for additional protection. Minimizing the inter-winding capacitance of the isolated power supply or transformer is necessary to reduce switching loss in hard-switched applications. Furthermore, capacitance across the isolated bias supply inject high currents into the signal-ground of the LMG365xR025 and can cause problematic ground-bounce transients. A common-mode choke can alleviate most of these issues.

9.3.2 Using a Bootstrap Diode

In half-bridge configuration, a floating supply is necessary for the high-side device. To obtain the best performance of LMG365xR025, TI highly recommends [Using an Isolated Power Supply](#). A bootstrap supply can be used with the recommendations of this section.

9.3.2.1 Diode Selection

The LMG365xR025 offers no reverse-recovery charge and very limited output charge. Hard-switching circuits using the LMG365xR025 also exhibit high voltage slew rates. A compatible bootstrap diode must not introduce high output charge and reverse-recovery charge.

A silicon carbide diode, like the GB01SLT06-214, can be used to avoid reverse-recovery effects. The SiC diode has an output charge of 3nC. Although there is additional loss from its output charge, it does not dominate the losses of the switching stage.

9.3.2.2 Managing the Bootstrap Voltage

In a synchronous buck or other converter where the low-side switch occasionally operates in third-quadrant, the bootstrap supply charges through a path that includes the third-quadrant voltage drop of the low-side LMG365xR025 during the dead time as shown in [Charging Path for Bootstrap Diode](#). This third-quadrant drop can be large, which can overcharge the bootstrap supply in certain conditions. The V_{DD} supply of LMG365xR025 must be kept below 28V.

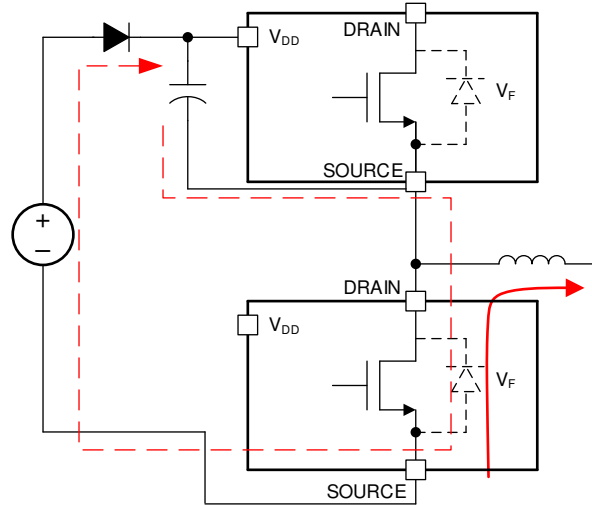

Figure 9-7. Charging Path for Bootstrap Diode

As shown in [Suggested Bootstrap Regulation Circuit](#), the recommended bootstrap supply includes a bootstrap diode, a series resistor, and a 26V TVS or Zener diode in parallel with the V_{DD} bypass capacitor to prevent damaging the high-side LMG365xR025. The series resistor limits the charging current at start-up and when the low-side device is operating in third-quadrant mode. This resistor must be selected to allow sufficient current to power the LMG365xR025 at the desired operating frequency. At 100kHz operation, TI recommends a value of approximately 2Ω . At higher frequencies, this resistor value must be reduced or the resistor omitted entirely to ensure sufficient supply current.

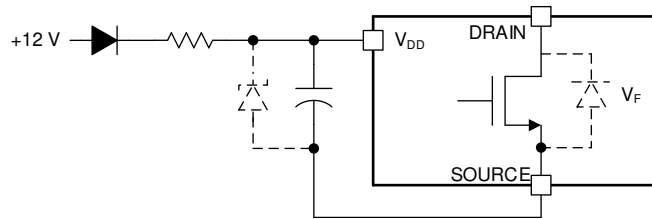

Figure 9-8. Suggested Bootstrap Regulation Circuit

9.4 Layout

9.4.1 Layout Guidelines

The layout of the LMG365xR025 is critical to its performance and functionality. Because the half-bridge configuration is typically used with these GaN devices, layout recommendations are considered with this configuration. A four-layer or higher layer count board is required to reduce the parasitic inductances of the layout to achieve suitable performance. Critical layout guidelines are summarized below, and more details are further elaborated in the following sections.

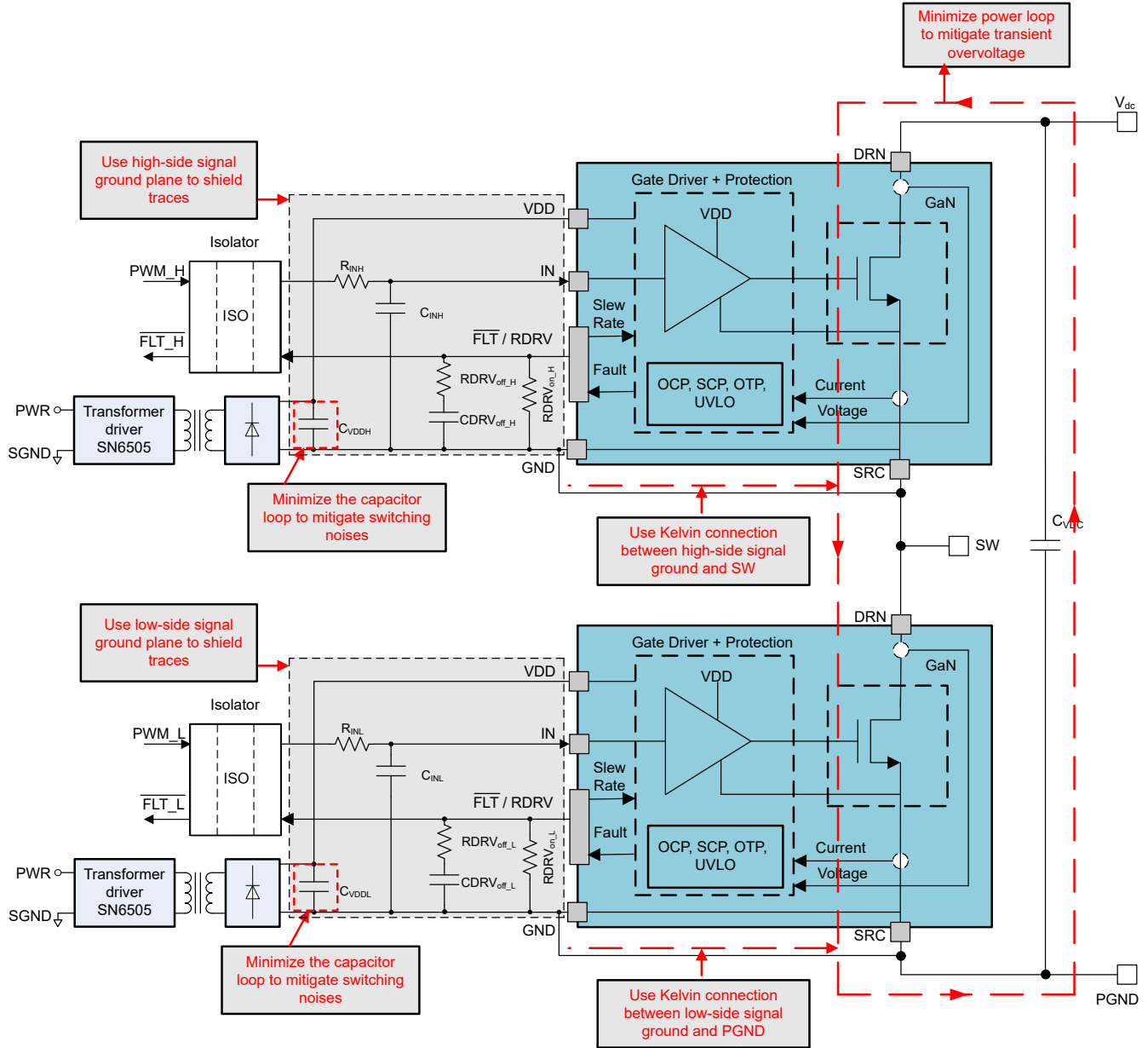

Figure 9-9. LMG3650R025 Typical Schematic With Layout Considerations

ADVANCE INFORMATION

ADVANCE INFORMATION

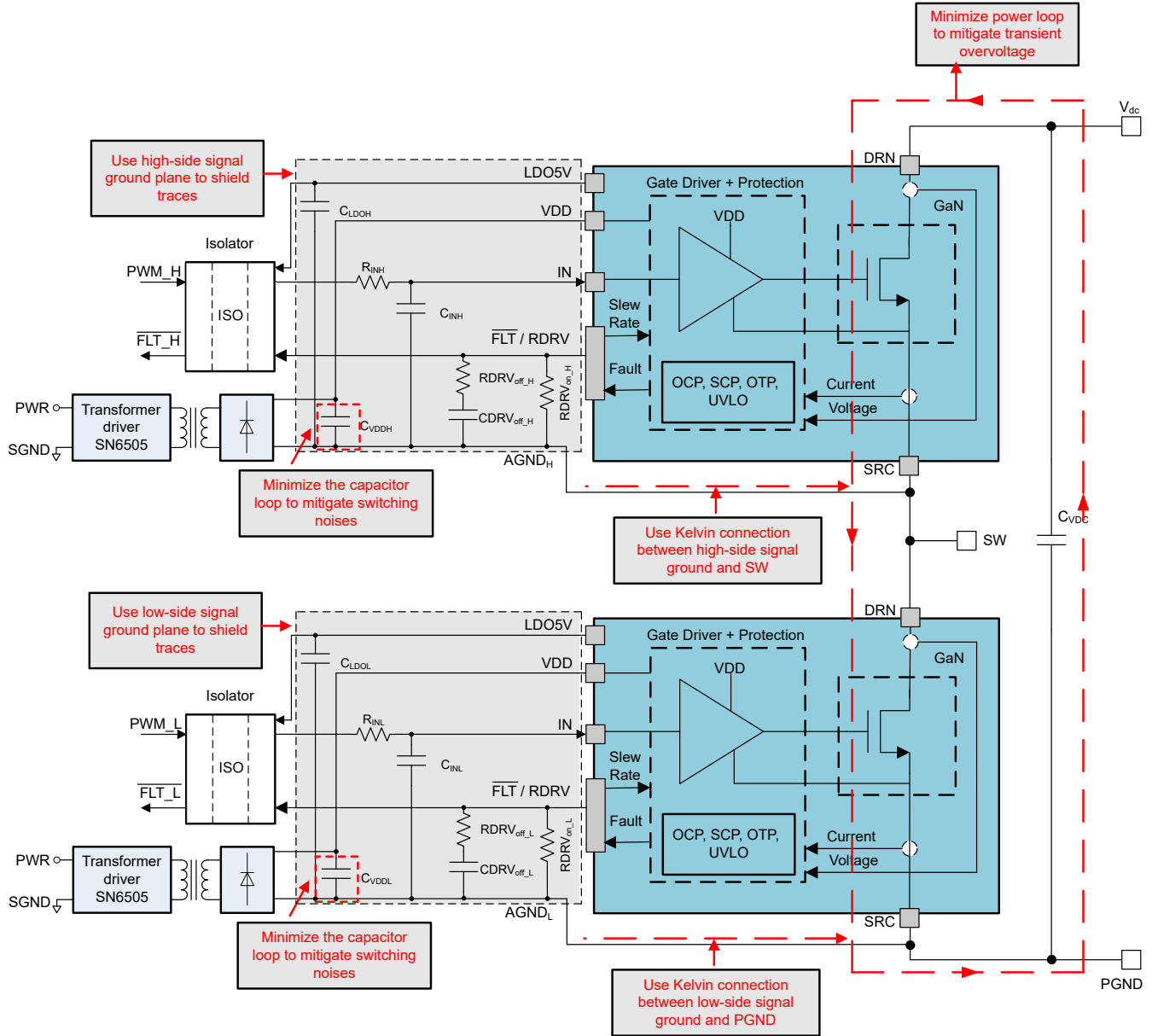

Figure 9-10. LMG3651R025 Typical Schematic With Layout Considerations

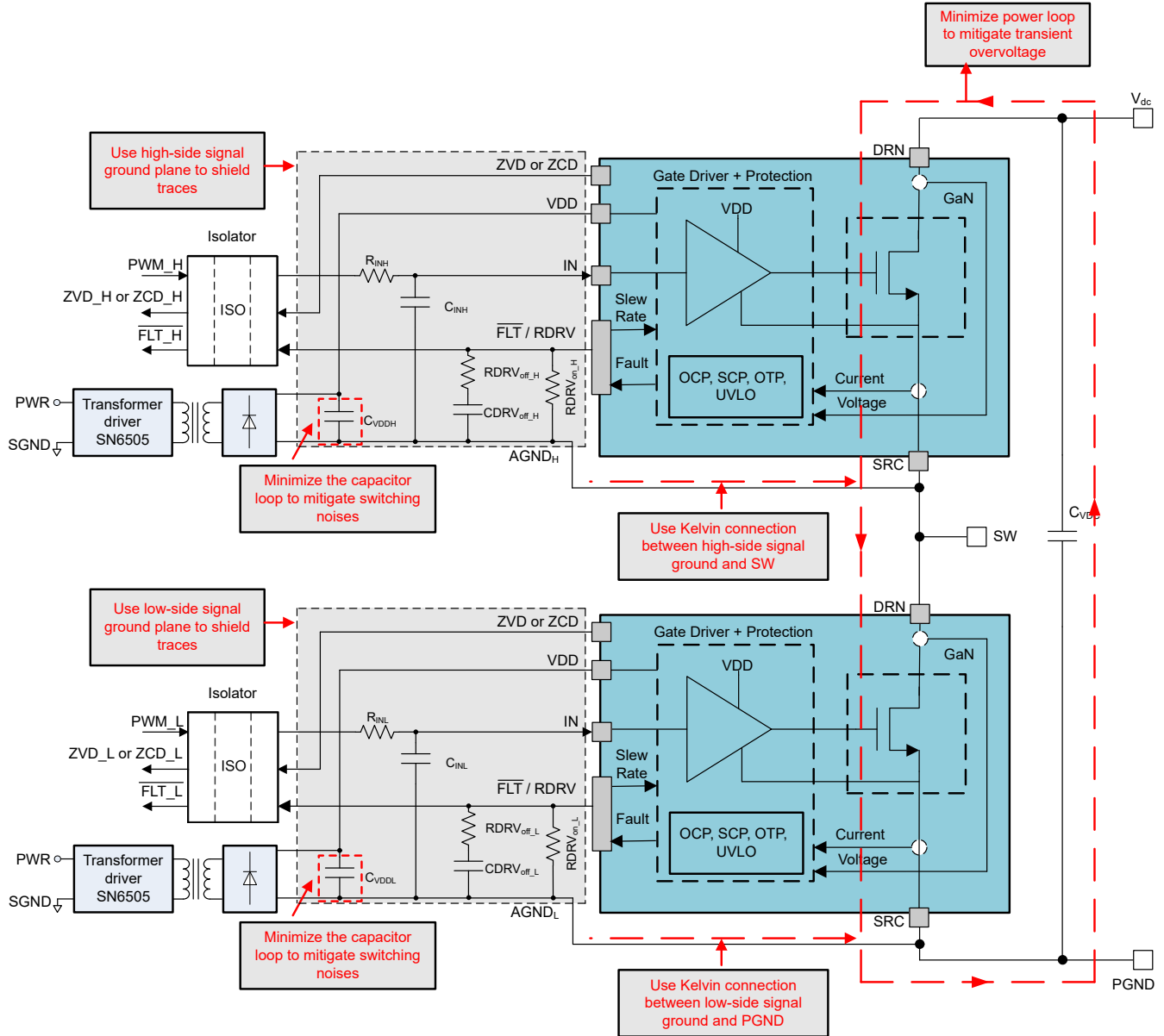

Figure 9-11. LMG3656R025 or LMG3657R025 Typical Schematic With Layout Considerations

ADVANCE INFORMATION

10 Device and Documentation Support

TI offers an extensive line of development tools. Tools and software to evaluate the performance of the device, generate code, and develop solutions are listed below.

10.1 Receiving Notification of Documentation Updates

To receive notification of documentation updates, navigate to the device product folder on ti.com. Click on *Notifications* to register and receive a weekly digest of any product information that has changed. For change details, review the revision history included in any revised document.

10.2 Support Resources

TI E2E™ [support forums](#) are an engineer's go-to source for fast, verified answers and design help — straight from the experts. Search existing answers or ask your own question to get the quick design help you need.

Linked content is provided "AS IS" by the respective contributors. They do not constitute TI specifications and do not necessarily reflect TI's views; see TI's [Terms of Use](#).

10.3 Trademarks

FlyBuck™ and TI E2E™ are trademarks of Texas Instruments. All trademarks are the property of their respective owners.

10.4 Electrostatic Discharge Caution



This integrated circuit can be damaged by ESD. Texas Instruments recommends that all integrated circuits be handled with appropriate precautions. Failure to observe proper handling and installation procedures can cause damage.

ESD damage can range from subtle performance degradation to complete device failure. Precision integrated circuits may be more susceptible to damage because very small parametric changes could cause the device not to meet its published specifications.

10.5 Glossary

[TI Glossary](#) This glossary lists and explains terms, acronyms, and definitions.

11 Revision History

NOTE: Page numbers for previous revisions may differ from page numbers in the current version.

DATE	REVISION	NOTES
February 2025	*	Initial Release

12 Mechanical, Packaging, and Orderable Information

The following pages include mechanical, packaging, and orderable information. This information is the most current data available for the designated devices. This data is subject to change without notice and revision of this document. For browser-based versions of this data sheet, refer to the left-hand navigation.

ADVANCE INFORMATION

EXAMPLE BOARD LAYOUT

KLA0009A

TOLL - 2.35 mm max height

TO LEADLESS

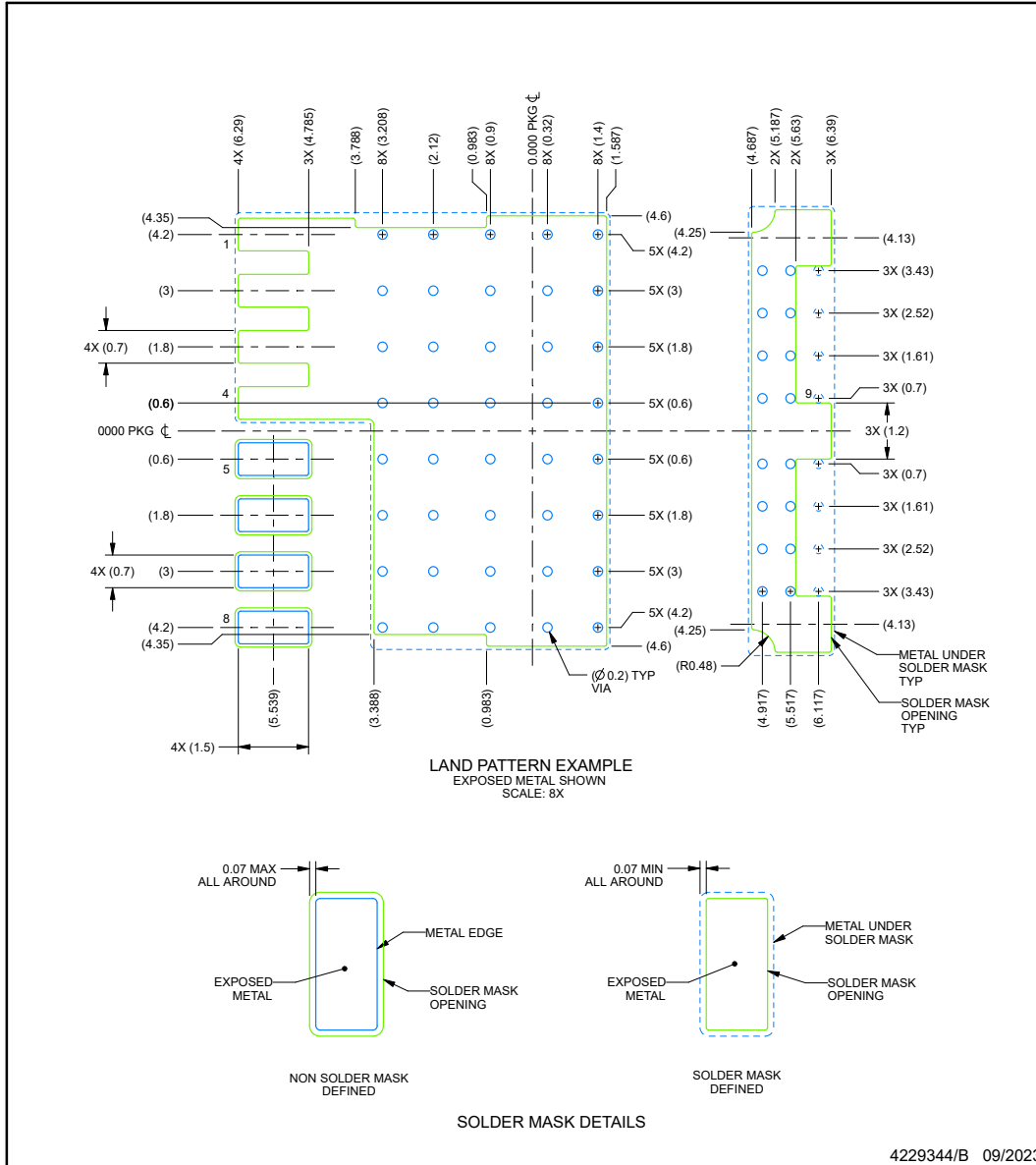

NOTES: (continued)

- This package is designed to be soldered to a thermal pad on the board. For more information, see Texas Instruments literature number SLUA271 (www.ti.com/lit/slua271).
- Vias are optional depending on application, refer to device data sheet. If any vias are implemented, refer to their locations shown on this view. It is recommended that vias under paste be filled, plugged or tented.

EXAMPLE STENCIL DESIGN

KLA0009A

TOLL - 2.35 mm max height

TO LEADLESS

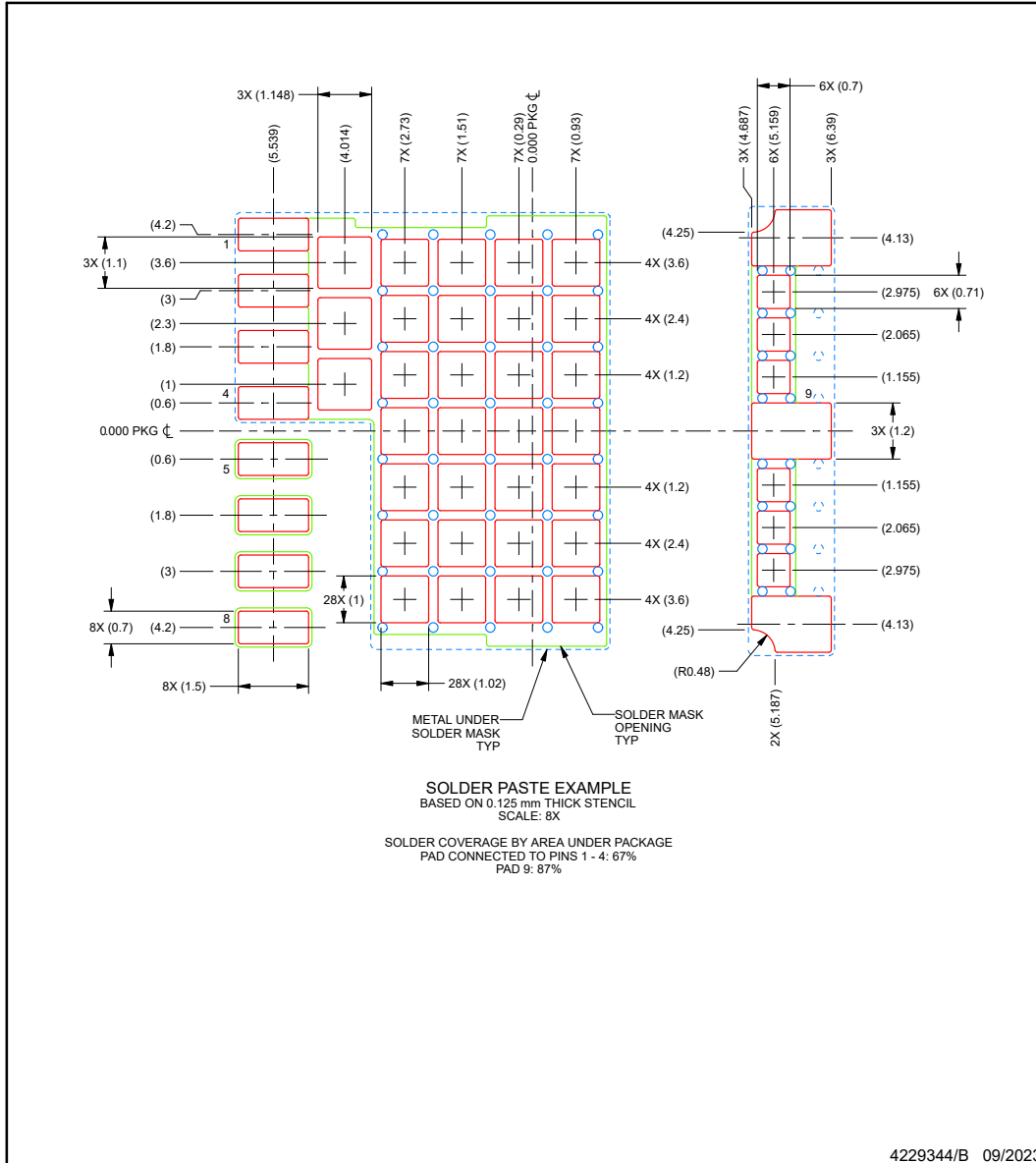

NOTES: (continued)

6. Laser cutting apertures with trapezoidal walls and rounded corners may offer better paste release. IPC-7525 may have alternate design recommendations.

ADVANCE INFORMATION

12.1 Tape and Reel Information

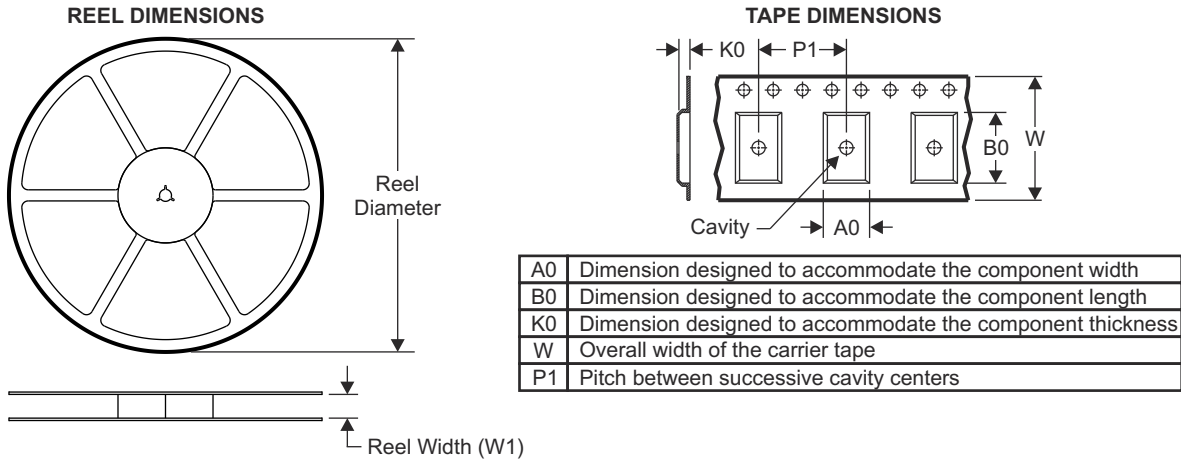

QUADRANT ASSIGNMENTS FOR PIN 1 ORIENTATION IN TAPE

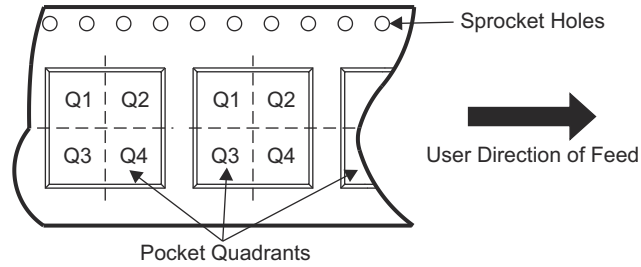

Device	Package Type	Package Drawing	Pins	SPQ	Reel Diameter (mm)	Reel Width W1 (mm)	A0 (mm)	B0 (mm)	K0 (mm)	P1 (mm)	W (mm)	Pin1 Quadrant
XLMG3650R025KLAT	TO	KLA	9	2000	330.0	24.4	10.20	11.98	2.6	12.0	21.0	Q2

ADVANCE INFORMATION

TAPE AND REEL BOX DIMENSIONS



Device	Package Type	Package Drawing	Pins	SPQ	Length (mm)	Width (mm)	Height (mm)
XLMG3650R025KLAT	TO	KLA	9	2000	356.0	356.0	45.0

ADVANCE INFORMATION

PACKAGING INFORMATION

Orderable Device	Status (1)	Package Type	Package Drawing	Pins	Package Qty	Eco Plan (2)	Lead finish/ Ball material (6)	MSL Peak Temp (3)	Op Temp (°C)	Device Marking (4/5)	Samples
XLMG3650R025KLAT	ACTIVE	TO	KLA	9	250	TBD	Call TI	Call TI	-40 to 175		Samples

(1) The marketing status values are defined as follows:

ACTIVE: Product device recommended for new designs.

LIFEBUY: TI has announced that the device will be discontinued, and a lifetime-buy period is in effect.

NRND: Not recommended for new designs. Device is in production to support existing customers, but TI does not recommend using this part in a new design.

PREVIEW: Device has been announced but is not in production. Samples may or may not be available.

OBSELETE: TI has discontinued the production of the device.

(2) **RoHS:** TI defines "RoHS" to mean semiconductor products that are compliant with the current EU RoHS requirements for all 10 RoHS substances, including the requirement that RoHS substance do not exceed 0.1% by weight in homogeneous materials. Where designed to be soldered at high temperatures, "RoHS" products are suitable for use in specified lead-free processes. TI may reference these types of products as "Pb-Free".

RoHS Exempt: TI defines "RoHS Exempt" to mean products that contain lead but are compliant with EU RoHS pursuant to a specific EU RoHS exemption.

Green: TI defines "Green" to mean the content of Chlorine (Cl) and Bromine (Br) based flame retardants meet JS709B low halogen requirements of <=1000ppm threshold. Antimony trioxide based flame retardants must also meet the <=1000ppm threshold requirement.

(3) MSL, Peak Temp. - The Moisture Sensitivity Level rating according to the JEDEC industry standard classifications, and peak solder temperature.

(4) There may be additional marking, which relates to the logo, the lot trace code information, or the environmental category on the device.

(5) Multiple Device Markings will be inside parentheses. Only one Device Marking contained in parentheses and separated by a "-" will appear on a device. If a line is indented then it is a continuation of the previous line and the two combined represent the entire Device Marking for that device.

(6) Lead finish/Ball material - Orderable Devices may have multiple material finish options. Finish options are separated by a vertical ruled line. Lead finish/Ball material values may wrap to two lines if the finish value exceeds the maximum column width.

Important Information and Disclaimer:The information provided on this page represents TI's knowledge and belief as of the date that it is provided. TI bases its knowledge and belief on information provided by third parties, and makes no representation or warranty as to the accuracy of such information. Efforts are underway to better integrate information from third parties. TI has taken and continues to take reasonable steps to provide representative and accurate information but may not have conducted destructive testing or chemical analysis on incoming materials and chemicals. TI and TI suppliers consider certain information to be proprietary, and thus CAS numbers and other limited information may not be available for release.

In no event shall TI's liability arising out of such information exceed the total purchase price of the TI part(s) at issue in this document sold by TI to Customer on an annual basis.

IMPORTANT NOTICE AND DISCLAIMER

TI PROVIDES TECHNICAL AND RELIABILITY DATA (INCLUDING DATA SHEETS), DESIGN RESOURCES (INCLUDING REFERENCE DESIGNS), APPLICATION OR OTHER DESIGN ADVICE, WEB TOOLS, SAFETY INFORMATION, AND OTHER RESOURCES "AS IS" AND WITH ALL FAULTS, AND DISCLAIMS ALL WARRANTIES, EXPRESS AND IMPLIED, INCLUDING WITHOUT LIMITATION ANY IMPLIED WARRANTIES OF MERCHANTABILITY, FITNESS FOR A PARTICULAR PURPOSE OR NON-INFRINGEMENT OF THIRD PARTY INTELLECTUAL PROPERTY RIGHTS.

These resources are intended for skilled developers designing with TI products. You are solely responsible for (1) selecting the appropriate TI products for your application, (2) designing, validating and testing your application, and (3) ensuring your application meets applicable standards, and any other safety, security, regulatory or other requirements.

These resources are subject to change without notice. TI grants you permission to use these resources only for development of an application that uses the TI products described in the resource. Other reproduction and display of these resources is prohibited. No license is granted to any other TI intellectual property right or to any third party intellectual property right. TI disclaims responsibility for, and you will fully indemnify TI and its representatives against, any claims, damages, costs, losses, and liabilities arising out of your use of these resources.

TI's products are provided subject to [TI's Terms of Sale](#) or other applicable terms available either on [ti.com](#) or provided in conjunction with such TI products. TI's provision of these resources does not expand or otherwise alter TI's applicable warranties or warranty disclaimers for TI products.

TI objects to and rejects any additional or different terms you may have proposed.

Mailing Address: Texas Instruments, Post Office Box 655303, Dallas, Texas 75265

Copyright © 2025, Texas Instruments Incorporated