

# OPA859 1.8GHz Unity-Gain Bandwidth, 3.3nV/ $\sqrt{\text{Hz}}$ , FET Input Amplifier

## 1 Features

- High unity-gain bandwidth: 1.8GHz
- Gain bandwidth product: 900MHz
- Ultra-low bias current MOSFET inputs: 10pA
- Low input voltage noise: 3.3nV/ $\sqrt{\text{Hz}}$
- Slew rate: 1150V/ $\mu\text{s}$
- Low Input capacitance:
  - Common-mode: 0.6pF
  - Differential: 0.2pF
- Wide input common-mode range:
  - 1.4V from positive supply
  - Includes negative supply
- 2.5V<sub>PP</sub> output swing in TIA configuration
- Supply voltage range: 3.3V to 5.25V
- Quiescent current: 20.5mA
- Package: 8-pin WSON
- Temperature range: -40°C to +125°C

## 2 Applications

- [Optical time domain reflectometry \(OTDR\)](#)
- [3D scanner](#)
- [Laser distance measurement](#)
- [Solid-state scanning LIDAR](#)
- [Optical ToF position sensor](#)
- [Drone vision](#)
- [Industrial robot LIDAR](#)
- [Vacuum robot LIDAR](#)
- Silicon photomultiplier (SiPM) buffer amplifier
- Photomultiplier tube post amplifier

## 3 Description

The OPA859 is a wideband, low-noise operational amplifier with CMOS inputs for wideband transimpedance and voltage amplifier applications. When the device is configured as a transimpedance amplifier (TIA), the 0.9GHz gain bandwidth product (GBWP) enables high closed-loop bandwidths in low-capacitance photodiode applications.

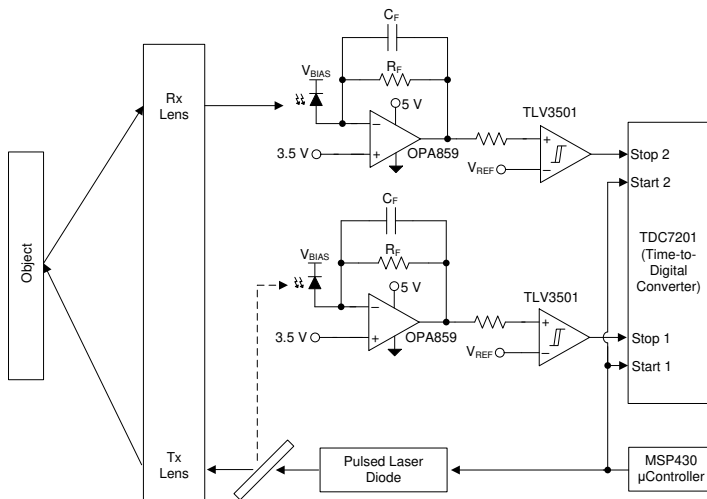
The following graph shows the bandwidth and noise performance of the OPA859 as a function of the photodiode capacitance when the amplifier is configured as a TIA. The total noise is calculated along a bandwidth range extending from dc to the calculated frequency ( $f$ ) on the left scale. The OPA859 package has a feedback pin (FB) that simplifies the feedback network connection between the input and the output.

The OPA859 is optimized to operate in optical time-of-flight (ToF) systems where the OPA859 is used with time-to-digital converters, such as the [TDC7201](#). Use the OPA859 to drive a high-speed analog-to-digital converter (ADC) in high-resolution LIDAR systems with a differential output amplifier, such as the [THS4541](#) or [LMH5401](#) devices.

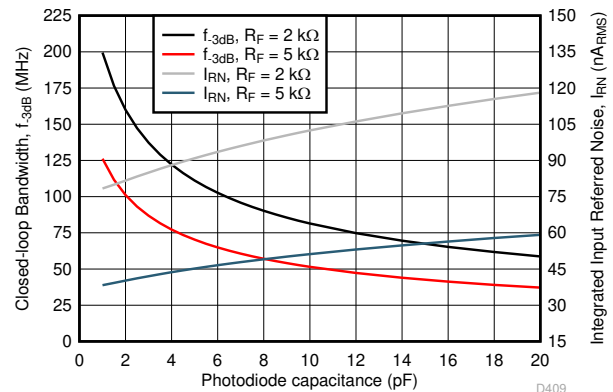
### Package Information

PART NUMBER <sup>(1)</sup>	PACKAGE <sup>(2)</sup>	PACKAGE SIZE <sup>(3)</sup>
OPA859	DSG (WSON, 8)	2mm × 2mm
	Bare die	0.751mm × 0.705mm

- (1) See the [Device Comparison Table](#).
- (2) For more information, see [Section 12](#).
- (3) The package size (length × width) is a nominal value and includes pins, where applicable.



High-Speed Time-of-Flight Receiver



Photodiode Capacitance vs Bandwidth and Noise

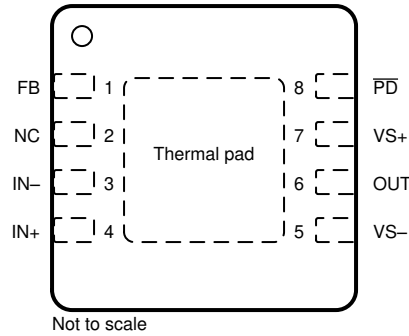
## Table of Contents

<b>1 Features</b> .....	<b>1</b>	8.4 Device Functional Modes.....	<b>20</b>
<b>2 Applications</b> .....	<b>1</b>	<b>9 Application and Implementation</b> .....	<b>21</b>
<b>3 Description</b> .....	<b>1</b>	9.1 Application Information.....	21
<b>4 Device Comparison Table</b> .....	<b>2</b>	9.2 Typical Applications.....	21
<b>5 Pin Configuration and Functions</b> .....	<b>3</b>	9.3 Power Supply Recommendations.....	24
<b>6 Specifications</b> .....	<b>5</b>	9.4 Layout.....	25
6.1 Absolute Maximum Ratings .....	5	<b>10 Device and Documentation Support</b> .....	<b>26</b>
6.2 ESD Ratings .....	5	10.1 Device Support.....	26
6.3 Recommended Operating Conditions .....	5	10.2 Documentation Support.....	26
6.4 Thermal Information .....	5	10.3 Receiving Notification of Documentation Updates..	26
6.5 Electrical Characteristics .....	6	10.4 Support Resources.....	26
6.6 Typical Characteristics.....	8	10.5 Trademarks.....	26
<b>7 Parameter Measurement Information</b> .....	<b>15</b>	10.6 Electrostatic Discharge Caution.....	26
<b>8 Detailed Description</b> .....	<b>16</b>	10.7 Glossary.....	26
8.1 Overview.....	16	<b>11 Revision History</b> .....	<b>26</b>
8.2 Functional Block Diagram.....	16	<b>12 Mechanical, Packaging, and Orderable Information</b> .....	<b>27</b>
8.3 Feature Description.....	17		

## 4 Device Comparison Table

DEVICE	INPUT TYPE	MINIMUM STABLE GAIN	VOLTAGE NOISE (nV/ $\sqrt{\text{Hz}}$ )	INPUT CAPACITANCE (pF)	GAIN BANDWIDTH (GHz)
OPA859	CMOS	1V/V	3.3	0.8	0.9
<a href="#">OPA858</a>	CMOS	7V/V	2.5	0.8	5.5
<a href="#">OPA855</a>	Bipolar	7V/V	0.98	0.8	8
<a href="#">LMH6629</a>	Bipolar	10V/V	0.69	5.7	4

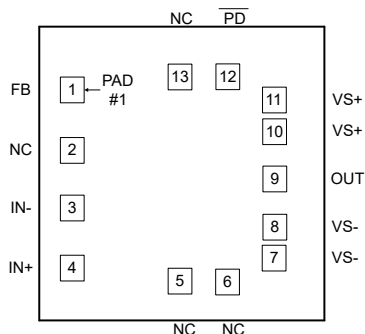
## 5 Pin Configuration and Functions



**Figure 5-1. DSG Package,  
8-Pin WSON With Exposed Thermal Pad  
(Top View)**

**Table 5-1. Pin Functions**

PIN		TYPE	DESCRIPTION
NAME	NO.		
FB	1	Input	Feedback connection to output of amplifier
IN-	3	Input	Inverting input
IN+	4	Input	Noninverting input
NC	2	—	Do not connect
OUT	6	Output	Amplifier output
PD	8	Input	Power down connection. $\overline{\text{PD}}$ = logic low = power off mode; $\text{PD}$ = logic high = normal operation.
VS-	5	—	Negative voltage supply
VS+	7	—	Positive voltage supply
Thermal pad		—	Connect the thermal pad to VS-



**Figure 5-2. Bare Die Package**

**Table 5-2. Bond Pad Functions**

PAD		TYPE	DESCRIPTION
NAME	NO.		
FB	1	Input	Feedback connection to output of amplifier
IN-	3	Input	Inverting input
IN+	4	Input	Noninverting input
NC	2,5,6,13	—	Do not connect
OUT	9	Output	Amplifier output
PD	12	Input	Power down connection. $\overline{PD}$ = logic low = power off mode; $\overline{PD}$ = logic high = normal operation.
VS-	7,8	—	Negative voltage supply
VS+	10,11	—	Positive voltage supply
Backside		—	Connect to VS-

**Table 5-3. Bare Die Information**

DIE THICKNESS	BACKSIDE FINISH	BACKSIDE POTENTIAL	BOND PAD METALLIZATION
381 μm	Silicon with backgrind	Wafer backside is electrically connected to VS-	AlCu

**Table 5-4. Bond Pad Coordinates of Bare Die Version in Microns**

PAD NUMBER	PAD NAME	X-MIN	Y-MIN	X-MAX	Y-MAX
1	FB	14.5	537.4	79.5	602.4
2	NC	14.5	379	79.5	444
3	IN-	14.5	227	79.5	292
4	IN+	14.5	68.6	79.5	133.6
5	NC	296.725	34.825	361.725	99.825
6	NC	421.725	34.825	486.725	99.825
7	VS-	545.5	93.8	610.5	158.8
8	VS-	545.5	178.8	610.5	243.8
9	OUT	545.5	303	610.5	368
10	VS+	545.5	427.2	610.5	492.2
11	VS+	545.5	512.2	610.5	577.2
12	$\overline{PD}$	421.325	571.175	486.325	636.175
13	NC	297.125	571.175	362.125	636.175

## 6 Specifications

### 6.1 Absolute Maximum Ratings

over operating free-air temperature range (unless otherwise noted)<sup>(1)</sup>

		MIN	MAX	UNIT
V <sub>S</sub>	Total supply voltage (V <sub>S+</sub> – V <sub>S-</sub> )		5.5	V
V <sub>IN+</sub> , V <sub>IN-</sub>	Input voltage	(V <sub>S-</sub> ) – 0.5	(V <sub>S+</sub> ) + 0.5	V
V <sub>ID</sub>	Differential input voltage		1	V
V <sub>OUT</sub>	Output voltage	(V <sub>S-</sub> ) – 0.5	(V <sub>S+</sub> ) + 0.5	V
I <sub>IN</sub>	Continuous input current		±10	mA
I <sub>OUT</sub>	Continuous output current <sup>(2)</sup>		±100	mA
T <sub>J</sub>	Junction temperature		150	°C
T <sub>A</sub>	Operating free-air temperature	–40	125	°C
T <sub>stg</sub>	Storage temperature	–65	150	°C

- (1) Operation outside the *Absolute Maximum Ratings* can cause permanent device damage. *Absolute Maximum Ratings* do not imply functional operation of the device at these or any other conditions beyond those listed under *Recommended Operating Conditions*. If used outside the *Recommended Operating Conditions* but within the *Absolute Maximum Ratings*, the device can not be fully functional, and this can affect device reliability, functionality, performance, and shorten the device lifetime.
- (2) Long-term continuous output current for electromigration limits.

### 6.2 ESD Ratings

			VALUE	UNIT
V <sub>(ESD)</sub>	Electrostatic discharge	Human-body model (HBM), per ANSI/ESDA/ JEDEC JS-001 <sup>(1)</sup>	±1000	V
		Charged-device model (CDM), per JEDEC specification JESD22-C101 <sup>(2)</sup>	±1500	

- (1) JEDEC document JEP155 states that 500-V HBM allows safe manufacturing with a standard ESD control process.
- (2) JEDEC document JEP157 states that 250-V CDM allows safe manufacturing with a standard ESD control process.

### 6.3 Recommended Operating Conditions

over operating free-air temperature range (unless otherwise noted)

		MIN	NOM	MAX	UNIT
V <sub>S</sub>	Total supply voltage (V <sub>S+</sub> – V <sub>S-</sub> )	3.3	5	5.25	V
T <sub>A</sub>	Operating free-air temperature	–40		125	°C

### 6.4 Thermal Information

THERMAL METRIC <sup>(1)</sup>		OPA859	UNIT
		DSG (WSON)	
		8 PINS	
R <sub>θJA</sub>	Junction-to-ambient thermal resistance	80.1	°C/W
R <sub>θJC(top)</sub>	Junction-to-case (top) thermal resistance	100	°C/W
R <sub>θJB</sub>	Junction-to-board thermal resistance	45	°C/W
Ψ <sub>JT</sub>	Junction-to-top characterization parameter	6.8	°C/W
Ψ <sub>JB</sub>	Junction-to-board characterization parameter	45.2	°C/W
R <sub>θJC(bot)</sub>	Junction-to-case (bottom) thermal resistance	22.7	°C/W

- (1) For more information about traditional and new thermal metrics, see the [Semiconductor and IC Package Thermal Metrics](#) application report.

## 6.5 Electrical Characteristics

$V_{S+} = 5\text{ V}$ ,  $V_{S-} = 0\text{ V}$ , input common-mode biased at midsupply, unity gain configuration,  $R_L = 200\ \Omega$ , output load is referenced to midsupply, and  $T_A \approx +25^\circ\text{C}$  (unless otherwise noted)

PARAMETER		TEST CONDITIONS	MIN	TYP	MAX	UNIT
<b>AC PERFORMANCE</b>						
SSBW	Small-signal bandwidth	$V_{OUT} = 100\text{ mV}_{PP}$		1.8		GHz
LSBW	Large-signal bandwidth	$V_{OUT} = 2\text{ V}_{PP}$		400		MHz
GBWP	Gain-bandwidth product			900		MHz
	Bandwidth for 0.1dB flatness			140		MHz
SR	Slew rate (10%–90%)	$V_{OUT} = 2\text{-V step}$		1150		V/ $\mu\text{s}$
$t_r$	Rise time	$V_{OUT} = 100\text{-mV step}$		0.3		ns
$t_f$	Fall time	$V_{OUT} = 100\text{-mV step}$		0.3		ns
	Settling time to 0.1%	$V_{OUT} = 2\text{-V step}$		8		ns
	Settling time to 0.001%	$V_{OUT} = 2\text{-V step}$		3000		ns
	Overshoot/undershoot	$V_{OUT} = 2\text{-V step}$		7%		
HD2	Second-order harmonic distortion	$f = 10\text{ MHz}$ , $V_{OUT} = 2\text{ V}_{PP}$		90		dBc
		$f = 100\text{ MHz}$ , $V_{OUT} = 2\text{ V}_{PP}$		60		
HD3	Third-order harmonic distortion	$f = 10\text{ MHz}$ , $V_{OUT} = 2\text{ V}_{PP}$		86		dBc
		$f = 100\text{ MHz}$ , $V_{OUT} = 2\text{ V}_{PP}$		64		
$e_n$	Input-referred voltage noise	$f = 1\text{ MHz}$		3.3		nV/ $\sqrt{\text{Hz}}$
$Z_{OUT}$	Closed-loop output impedance	$f = 1\text{ MHz}$		0.15		$\Omega$
<b>DC PERFORMANCE</b>						
$A_{OL}$	Open-loop voltage gain <sup>(1)</sup>		60	65		dB
$V_{OS}$	Input offset voltage <sup>(1)</sup>	$T_A = 25^\circ\text{C}$	–5	$\pm 0.9$	5	mV
$\Delta V_{OS}/\Delta T$	Input offset voltage drift	$T_A = -40^\circ\text{C to } +125^\circ\text{C}$		–2		$\mu\text{V}/^\circ\text{C}$
$I_{BN}$ , $I_{BI}$	Input bias current <sup>(1)</sup>	$T_A = 25^\circ\text{C}$	–5	$\pm 0.5$	5	pA
$I_{BOS}$	Input offset current <sup>(1)</sup>	$T_A = 25^\circ\text{C}$	–5	$\pm 0.1$	5	pA
CMRR	Common-mode rejection ratio <sup>(1)</sup>	$V_{CM} = \pm 0.5\text{ V}$	70	84		dB
<b>INPUT</b>						
	Common-mode input resistance			1		G $\Omega$
$C_{CM}$	Common-mode input capacitance			0.62		pF
	Differential input resistance			1		G $\Omega$
$C_{DIFF}$	Differential input capacitance			0.2		pF
$V_{IH}$	Common-mode input voltage (high) <sup>(1)</sup>	$V_{S+} = 3.3\text{ V}$ , CMRR > 66 dB	1.7	1.9		V
$V_{IL}$	Common-mode input voltage (low) <sup>(1)</sup>	$V_{S+} = 3.3\text{ V}$ , CMRR > 66 dB		0	0.4	V
$V_{IH}$	Common-mode input voltage (high) <sup>(1)</sup>	CMRR > 66 dB	3.4	3.6		V
		$T_A = -40^\circ\text{C to } +125^\circ\text{C}$ , CMRR > 66 dB		3.4		
$V_{IL}$	Common-mode input voltage (low) <sup>(1)</sup>	CMRR > 66 dB		0	0.4	V
		$T_A = -40^\circ\text{C to } +125^\circ\text{C}$ , CMRR > 66 dB		0.35	0.45	

## 6.5 Electrical Characteristics (continued)

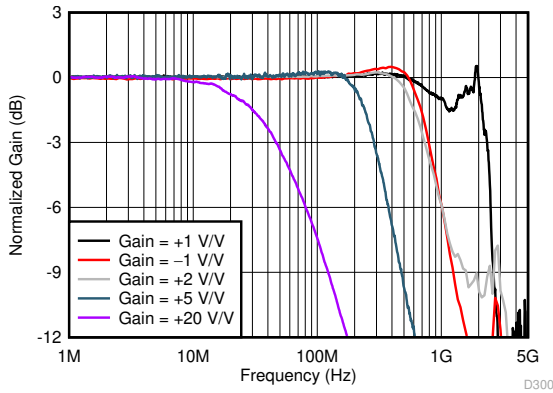
$V_{S+} = 5\text{ V}$ ,  $V_{S-} = 0\text{ V}$ , input common-mode biased at midsupply, unity gain configuration,  $R_L = 200\ \Omega$ , output load is referenced to midsupply, and  $T_A \approx +25^\circ\text{C}$  (unless otherwise noted)

PARAMETER		TEST CONDITIONS	MIN	TYP	MAX	UNIT
<b>OUTPUT</b>						
$V_{OH}$	Output voltage (high)	$V_{S+} = 3.3\text{ V}$ , $T_A = 25^\circ\text{C}$	2.3	2.4		V
		$T_A = 25^\circ\text{C}$	3.95	4.1		
		$T_A = -40^\circ\text{C}$ to $+125^\circ\text{C}$		3.9		
$V_{OL}$	Output voltage (low)	$V_{S+} = 3.3\text{ V}$ , $T_A = 25^\circ\text{C}$		1.05	1.15	V
		$T_A = 25^\circ\text{C}$		1.1	1.15	
		$T_A = -40^\circ\text{C}$ to $+125^\circ\text{C}$		1.2		
$I_{O\_LIN}$	Linear output drive (sink and source) <sup>(1)</sup>	$R_L = 10\ \Omega$ , $A_{OL} > 52\text{ dB}$	65	76		mA
		$T_A = -40^\circ\text{C}$ to $+125^\circ\text{C}$ , $R_L = 10\ \Omega$ , $A_{OL} > 52\text{ dB}$		64		
$I_{SC}$	Output short-circuit current <sup>(1)</sup>		85	105		mA
<b>POWER SUPPLY</b>						
$I_Q$	Quiescent current	$V_{S+} = 5\text{ V}$	18	20.5	24	mA
		$V_{S+} = 3.3\text{ V}$	17.5	20	23.5	
		$V_{S+} = 5.25\text{ V}$	18	21	24	
		$T_A = 125^\circ\text{C}$		24.5		
		$T_A = -40^\circ\text{C}$		18.5		
PSRR+	Positive power-supply rejection ratio <sup>(1)</sup>		66	74		dB
PSRR–	Negative power-supply rejection ratio <sup>(1)</sup>		64	72		
<b>POWER DOWN</b>						
	Disable voltage threshold	Amplifier off when < this voltage	0.65	1		V
	Enable voltage threshold	Amplifier on when > this voltage		1.5	1.8	V
	Power-down quiescent current			70	140	$\mu\text{A}$
	$\overline{\text{PD}}$ bias current			70	200	$\mu\text{A}$
	Turn-on time delay	Time to $V_{OUT} = 90\%$ of final value		25		ns
	Turn-off time delay			120		ns

(1) MIN and MAX limits do not apply for bare die.

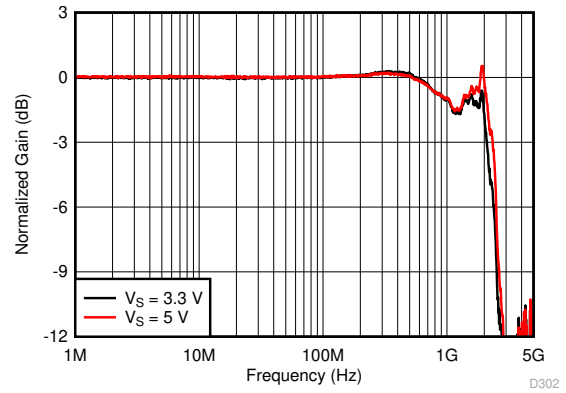
## 6.6 Typical Characteristics

at  $T_A = 25^\circ\text{C}$ ,  $V_{S+} = 2.5\text{ V}$ ,  $V_{S-} = -2.5\text{ V}$ ,  $V_{IN+} = 0\text{ V}$ , gain = 1 V/V,  $R_F = 0\ \Omega$ ,  $R_L = 200\ \Omega$ , and output load referenced to midsupply (unless otherwise noted)



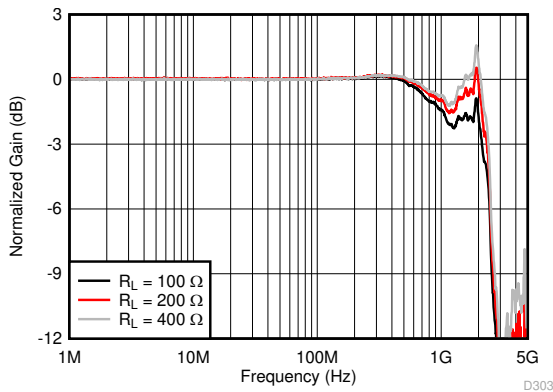
$V_{OUT} = 100\text{ mV}_{PP}$ ; see Section 7 for circuit configuration

Figure 6-1. Small-Signal Frequency Response vs Gain



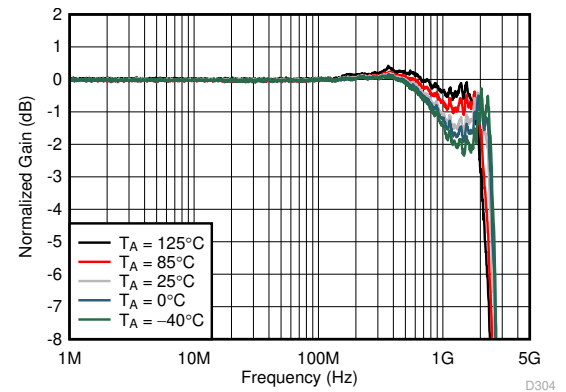
$V_{OUT} = 100\text{ mV}_{PP}$

Figure 6-2. Small-Signal Frequency Response vs Supply Voltage



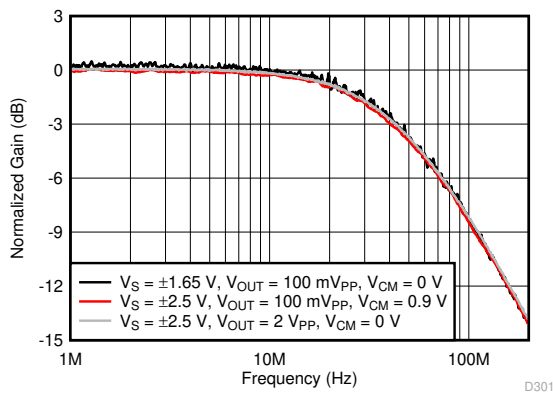
$V_{OUT} = 100\text{ mV}_{PP}$

Figure 6-3. Small-Signal Frequency Response vs Output Load



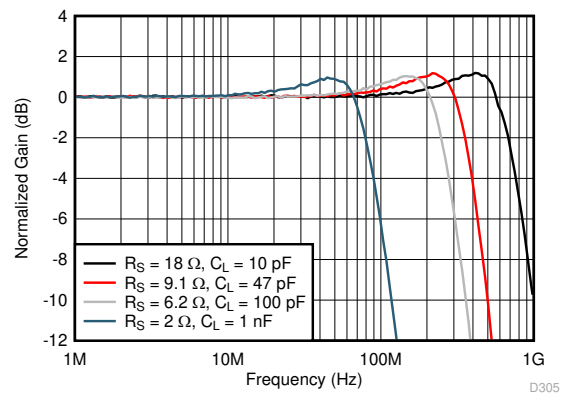
$V_{OUT} = 100\text{ mV}_{PP}$

Figure 6-4. Small-Signal Frequency Response vs Ambient Temperature



Gain = 20 V/V  $R_F = 453\ \Omega$

Figure 6-5. Frequency Response at Gain = 20 V/V



$V_{OUT} = 100\text{ mV}_{PP}$ , See Figure 7-4 for circuit configuration

Figure 6-6. Small-Signal Frequency Response vs Capacitive Load

### 6.6 Typical Characteristics (continued)

at  $T_A = 25^\circ\text{C}$ ,  $V_{S+} = 2.5\text{ V}$ ,  $V_{S-} = -2.5\text{ V}$ ,  $V_{IN+} = 0\text{ V}$ , gain = 1 V/V,  $R_F = 0\ \Omega$ ,  $R_L = 200\ \Omega$ , and output load referenced to midsupply (unless otherwise noted)

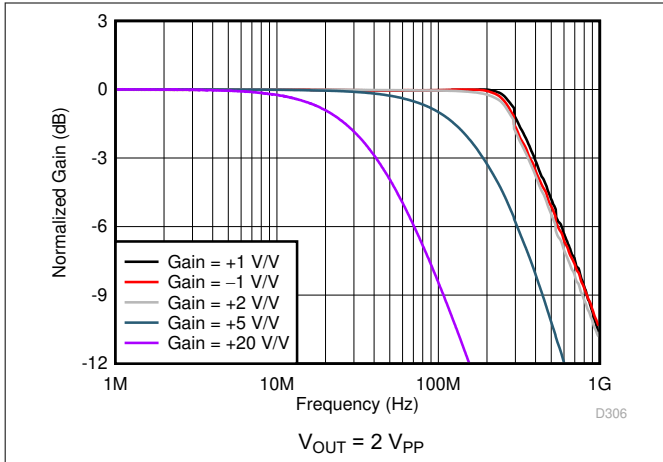


Figure 6-7. Large-Signal Frequency Response vs Gain

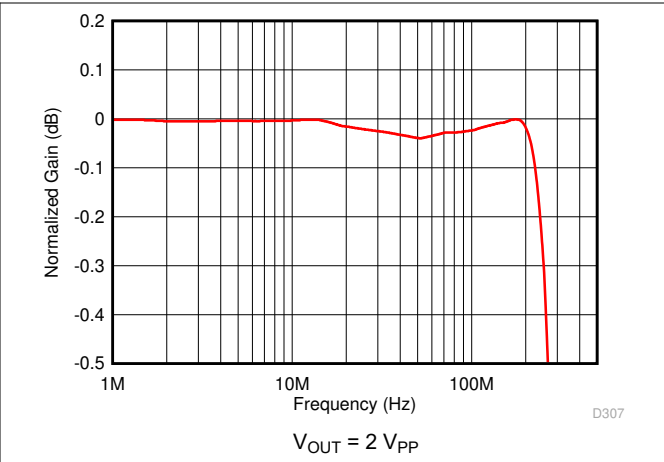


Figure 6-8. Large-Signal Response for 0.1-dB Gain Flatness

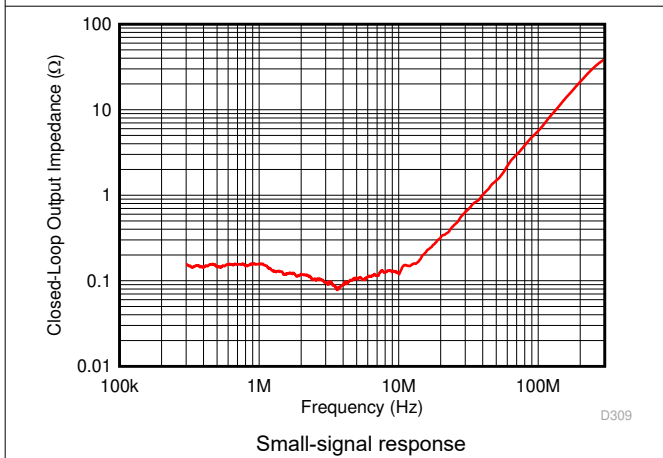


Figure 6-9. Closed-Loop Output Impedance vs Frequency

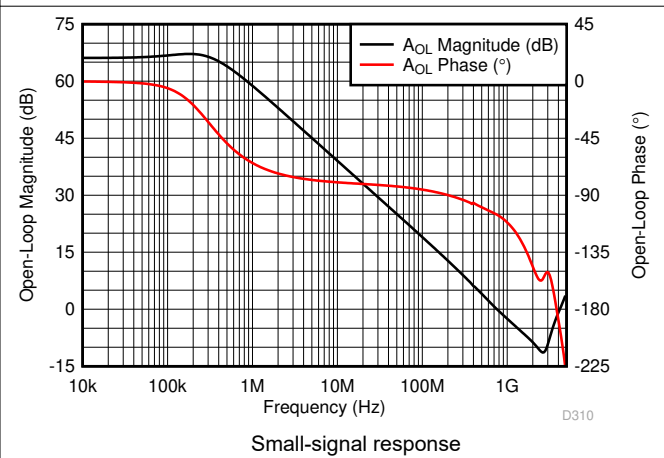


Figure 6-10. Open-Loop Magnitude and Phase vs Frequency

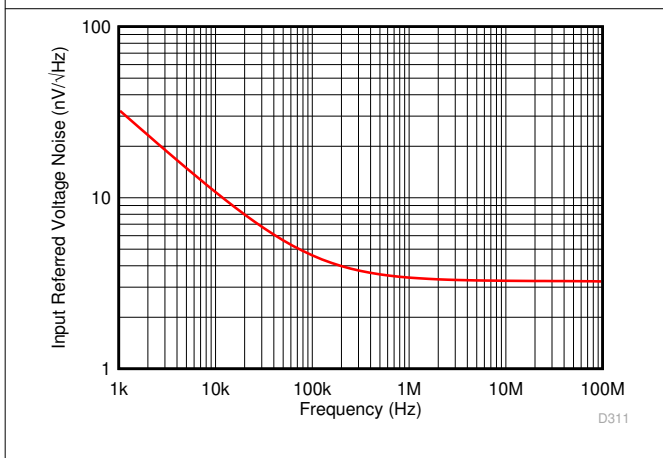


Figure 6-11. Voltage Noise Density vs Frequency

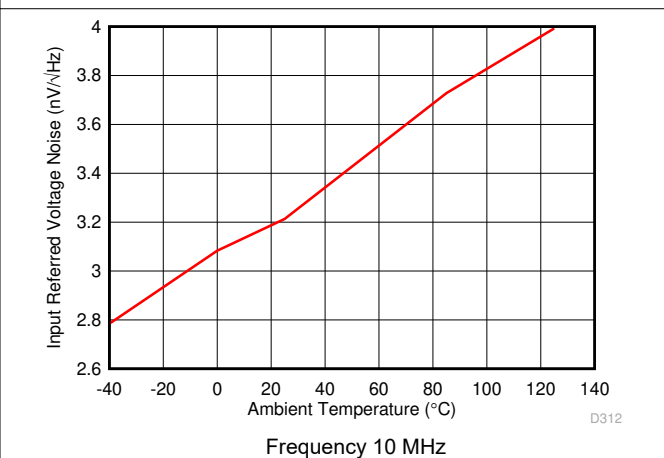


Figure 6-12. Voltage Noise Density vs Ambient Temperature

### 6.6 Typical Characteristics (continued)

at  $T_A = 25^\circ\text{C}$ ,  $V_{S+} = 2.5\text{ V}$ ,  $V_{S-} = -2.5\text{ V}$ ,  $V_{IN+} = 0\text{ V}$ , gain = 1 V/V,  $R_F = 0\ \Omega$ ,  $R_L = 200\ \Omega$ , and output load referenced to midsupply (unless otherwise noted)

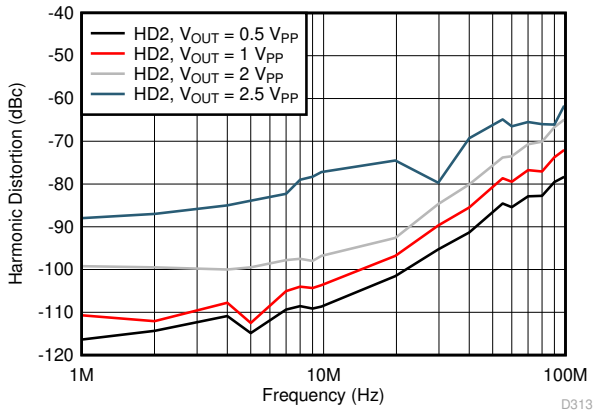


Figure 6-13. Harmonic Distortion (HD2) vs Output Swing

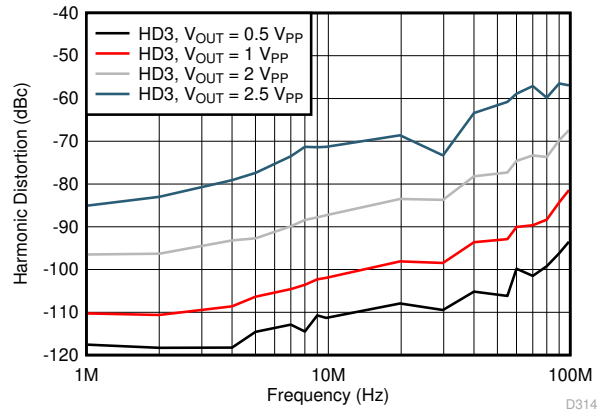


Figure 6-14. Harmonic Distortion (HD3) vs Output Swing

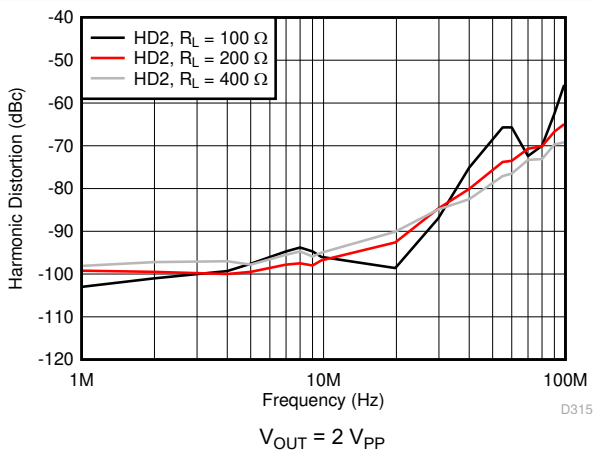


Figure 6-15. Harmonic Distortion (HD2) vs Output Load

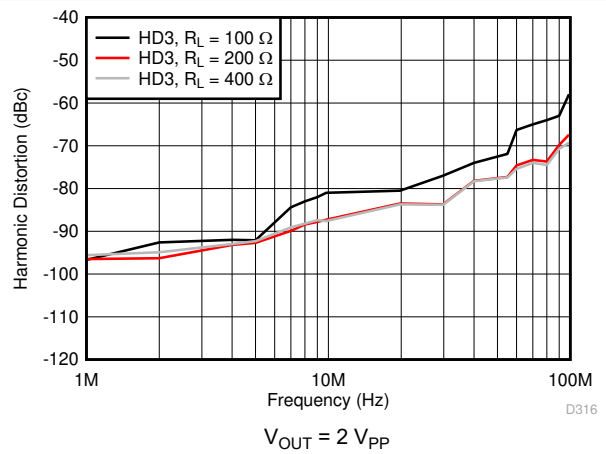


Figure 6-16. Harmonic Distortion (HD3) vs Output Load

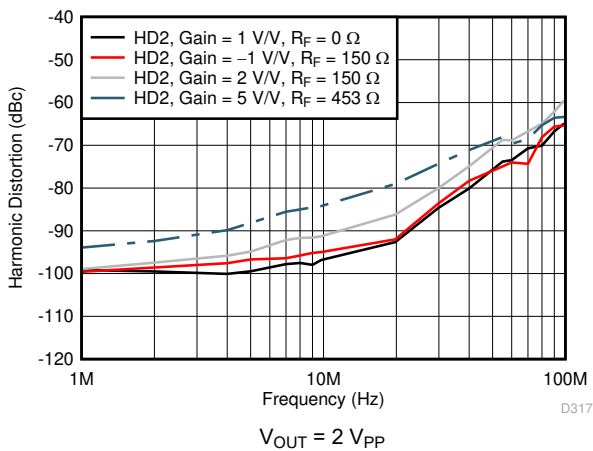


Figure 6-17. Harmonic Distortion (HD2) vs Gain

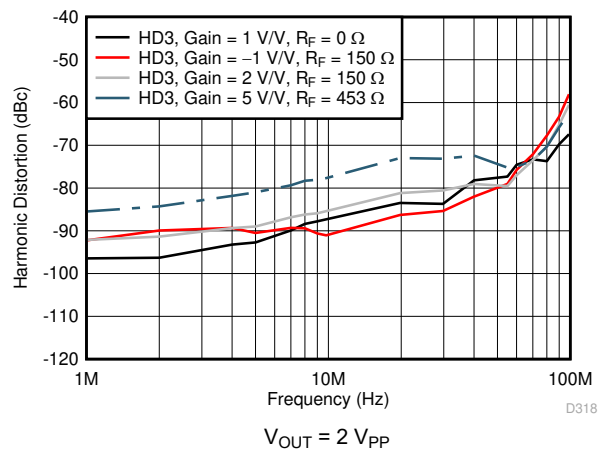
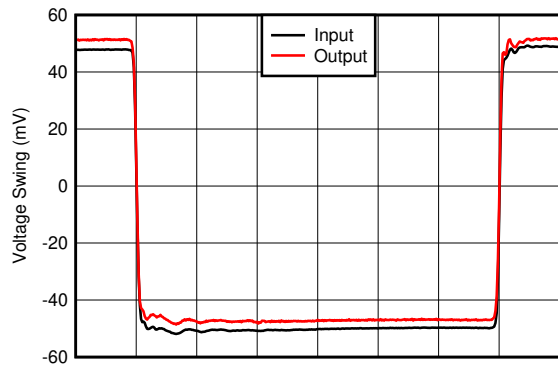


Figure 6-18. Harmonic Distortion (HD3) vs Gain

## 6.6 Typical Characteristics (continued)

at  $T_A = 25^\circ\text{C}$ ,  $V_{S+} = 2.5\text{ V}$ ,  $V_{S-} = -2.5\text{ V}$ ,  $V_{IN+} = 0\text{ V}$ , gain = 1 V/V,  $R_F = 0\ \Omega$ ,  $R_L = 200\ \Omega$ , and output load referenced to midsupply (unless otherwise noted)

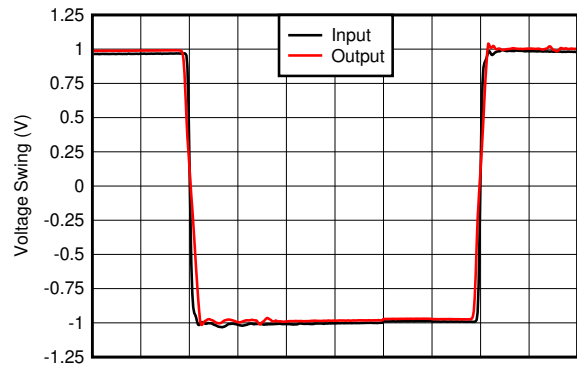


Time (5 ns/div)

D319

Average rise-and-fall time (10%–90%) = 450 ps

Figure 6-19. Small-Signal Transient Response

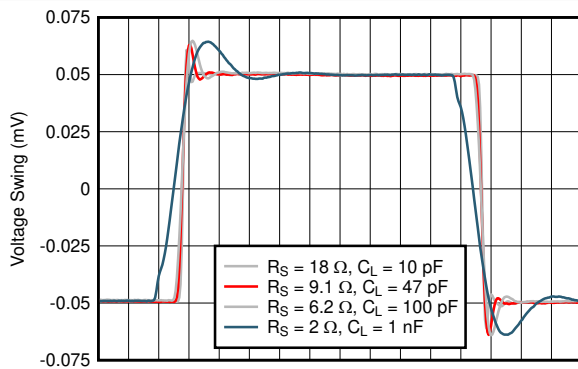


Time (5 ns/div)

D320

Slew rate: falling = 1160 V/ $\mu\text{s}$ , rising = 1400 V/ $\mu\text{s}$

Figure 6-20. Large-Signal Transient Response

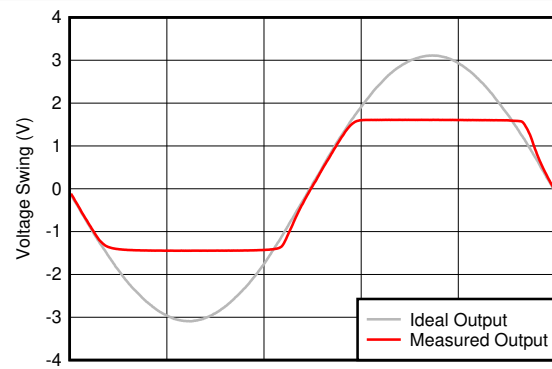


Time (5 ns/div)

D321

See Figure 7-4 for circuit configuration

Figure 6-21. Small-Signal Transient Response vs Capacitive Load

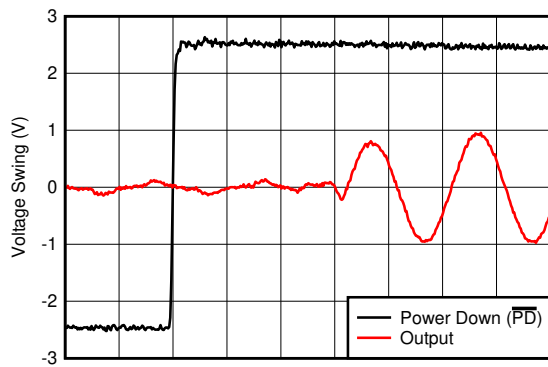


Time (10 ns/div)

D322

Gain = 5 V/V,  $R_F = 453\ \Omega$ , 2  $\times$  output overdrive

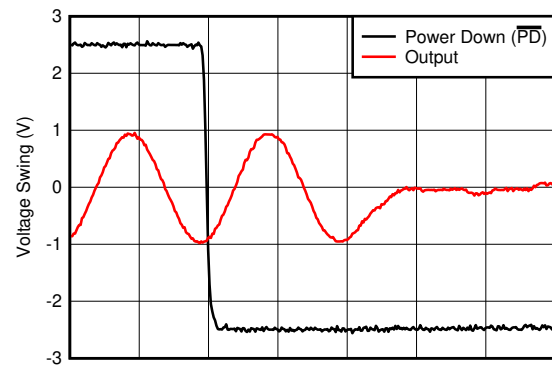
Figure 6-22. Output Overload Response



Time (5 ns/div)

D323

Figure 6-23. Turnon Transient Response



Time (5 ns/div)

D324

Figure 6-24. Turnoff Transient Response

### 6.6 Typical Characteristics (continued)

at  $T_A = 25^\circ\text{C}$ ,  $V_{S+} = 2.5\text{ V}$ ,  $V_{S-} = -2.5\text{ V}$ ,  $V_{IN+} = 0\text{ V}$ , gain = 1 V/V,  $R_F = 0\ \Omega$ ,  $R_L = 200\ \Omega$ , and output load referenced to midsupply (unless otherwise noted)

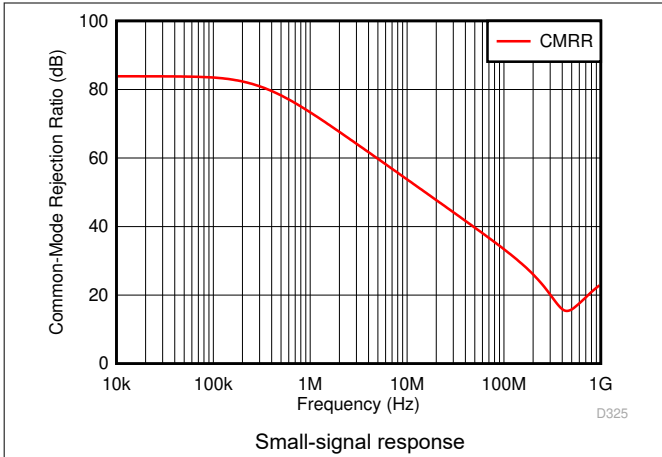


Figure 6-25. Common-Mode Rejection Ratio vs Frequency

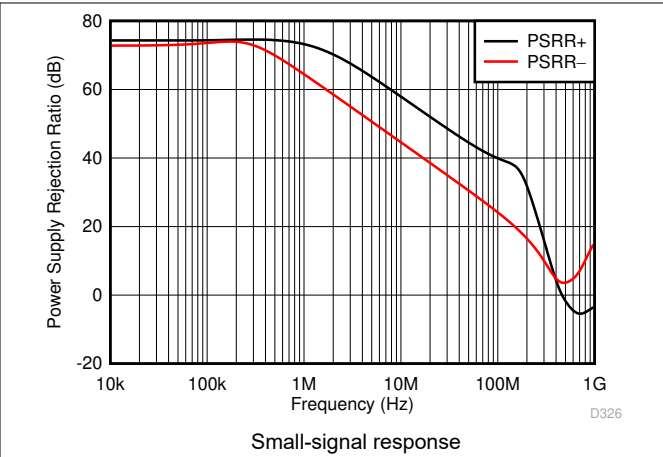


Figure 6-26. Power Supply Rejection Ratio vs Frequency

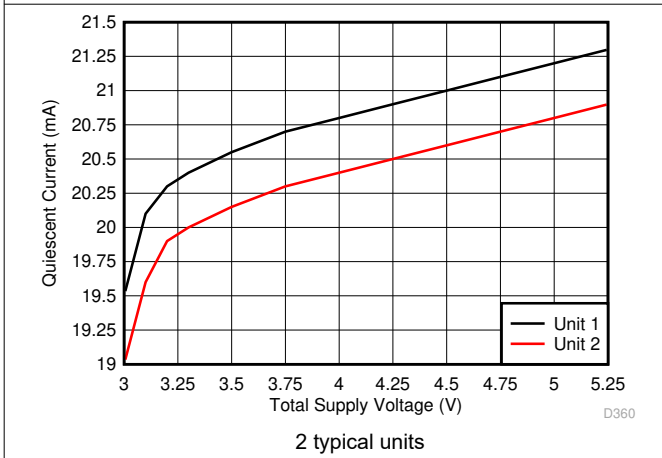


Figure 6-27. Quiescent Current vs Supply Voltage

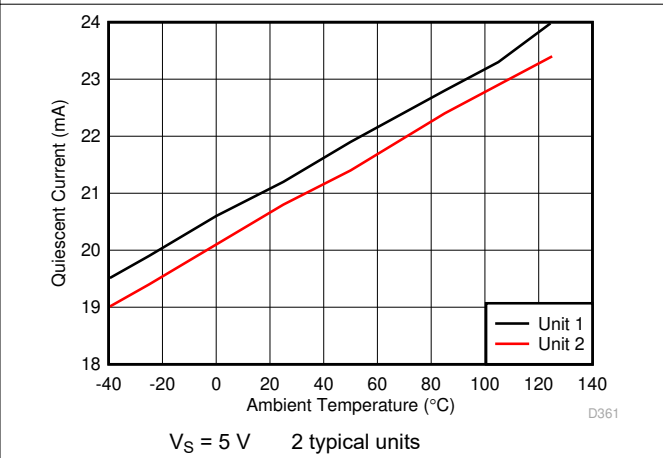


Figure 6-28. Quiescent Current vs Ambient Temperature

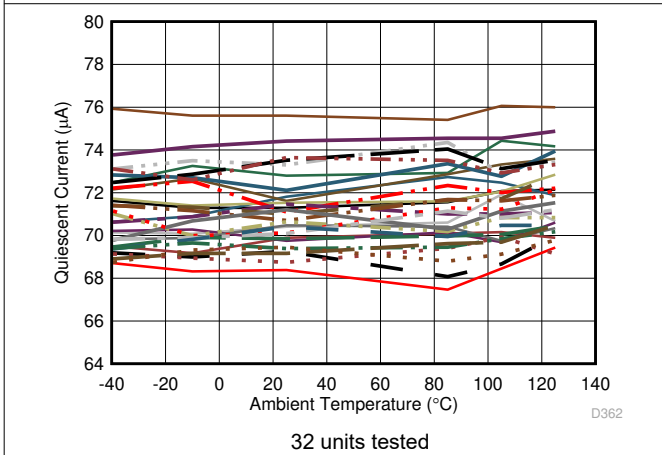


Figure 6-29. Quiescent Current (Amplifier Disabled) vs Ambient Temperature

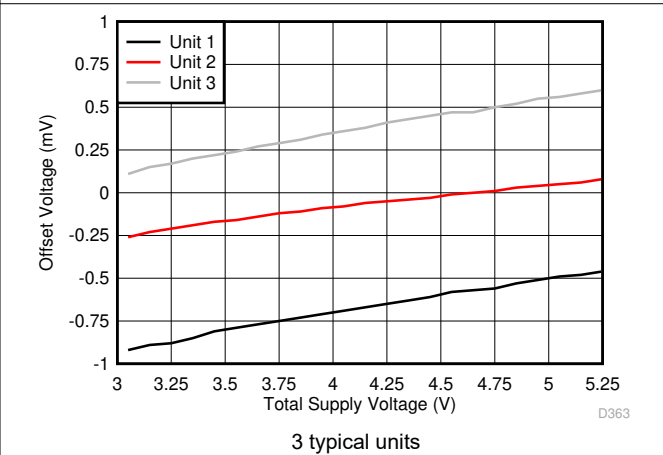
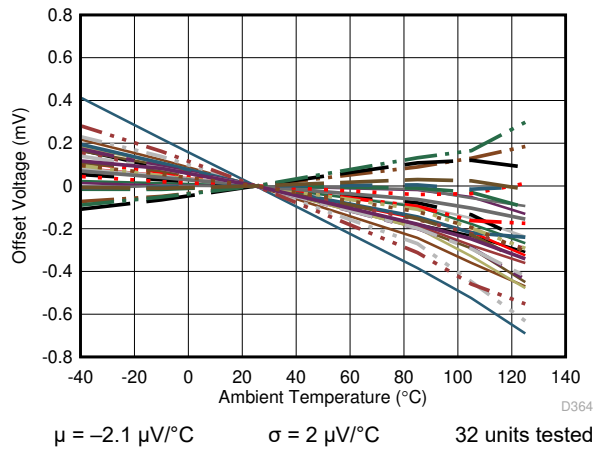


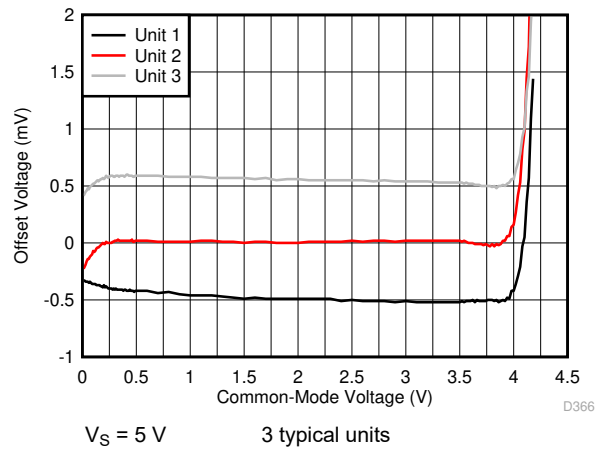
Figure 6-30. Offset Voltage vs Supply Voltage

## 6.6 Typical Characteristics (continued)

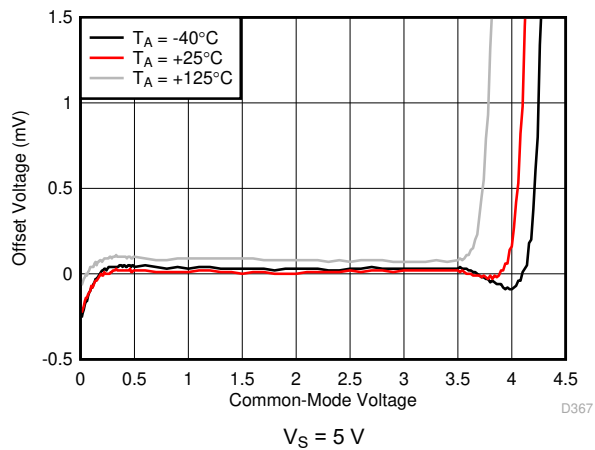
at  $T_A = 25^\circ\text{C}$ ,  $V_{S+} = 2.5\text{ V}$ ,  $V_{S-} = -2.5\text{ V}$ ,  $V_{IN+} = 0\text{ V}$ , gain = 1 V/V,  $R_F = 0\ \Omega$ ,  $R_L = 200\ \Omega$ , and output load referenced to midsupply (unless otherwise noted)



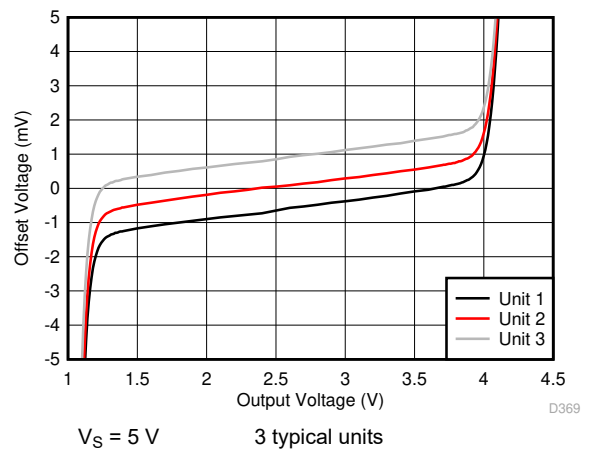
**Figure 6-31. Offset Voltage vs Ambient Temperature**



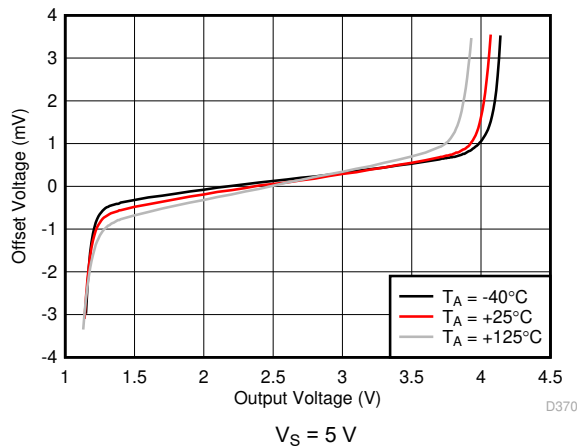
**Figure 6-32. Offset Voltage vs Input Common-Mode Voltage**



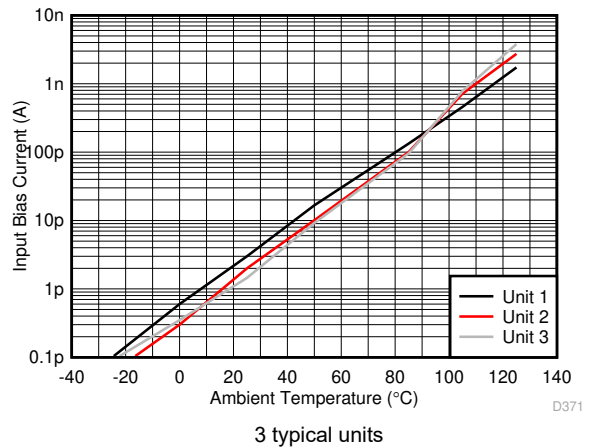
**Figure 6-33. Offset Voltage vs Input Common-Mode Voltage vs Ambient Temperature**



**Figure 6-34. Offset Voltage vs Output Swing**



**Figure 6-35. Offset Voltage vs Output Swing vs Ambient Temperature**



**Figure 6-36. Input Bias Current vs Ambient Temperature**

### 6.6 Typical Characteristics (continued)

at  $T_A = 25^\circ\text{C}$ ,  $V_{S+} = 2.5\text{ V}$ ,  $V_{S-} = -2.5\text{ V}$ ,  $V_{IN+} = 0\text{ V}$ , gain = 1 V/V,  $R_F = 0\ \Omega$ ,  $R_L = 200\ \Omega$ , and output load referenced to midsupply (unless otherwise noted)

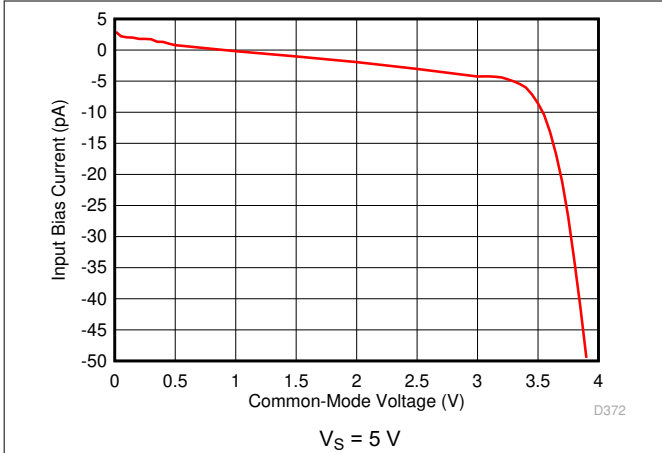


Figure 6-37. Input Bias Current vs Input Common-Mode Voltage

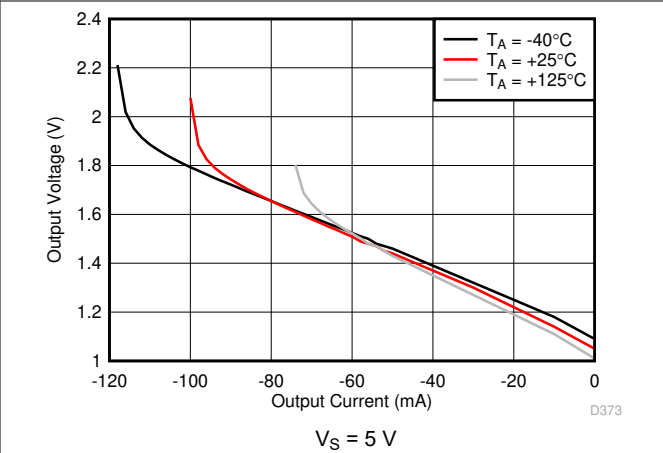


Figure 6-38. Output Swing vs Sinking Current

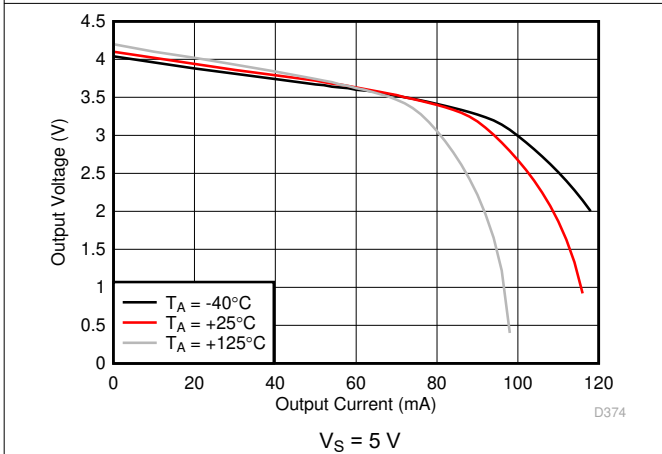


Figure 6-39. Output Swing vs Sourcing Current

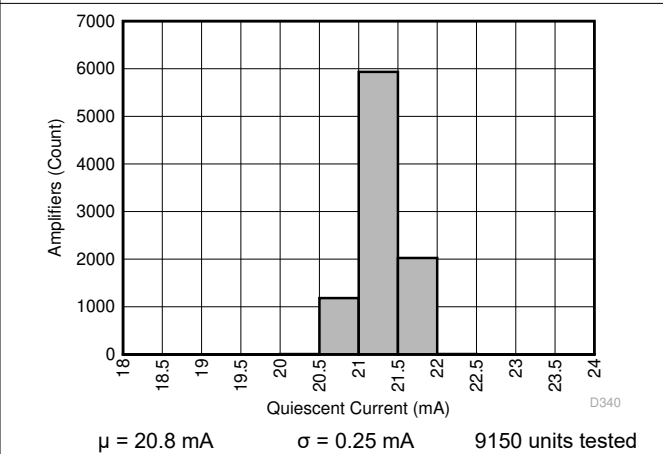


Figure 6-40. Quiescent Current Distribution

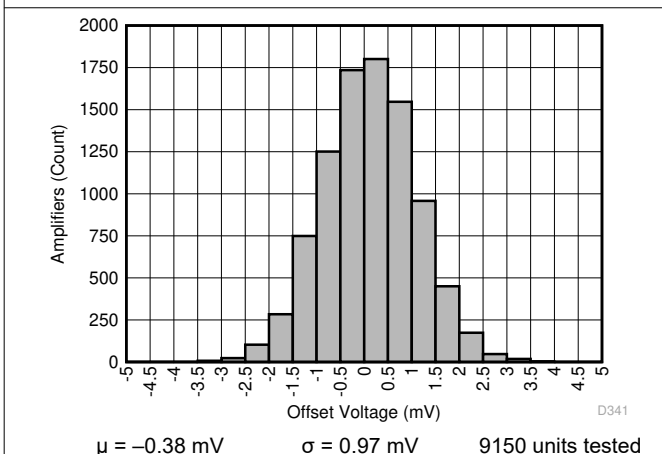


Figure 6-41. Offset Voltage Distribution

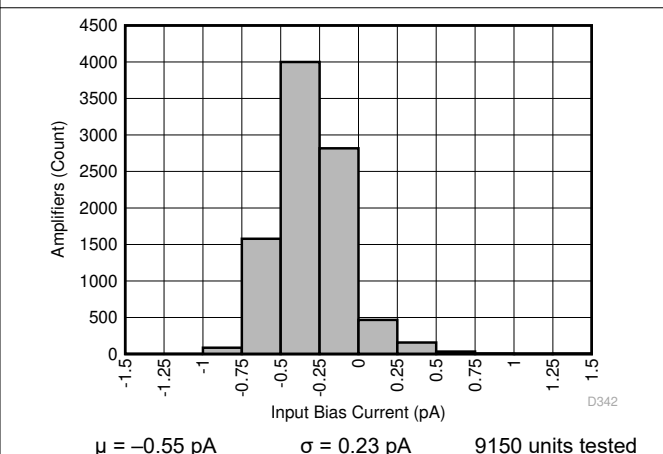
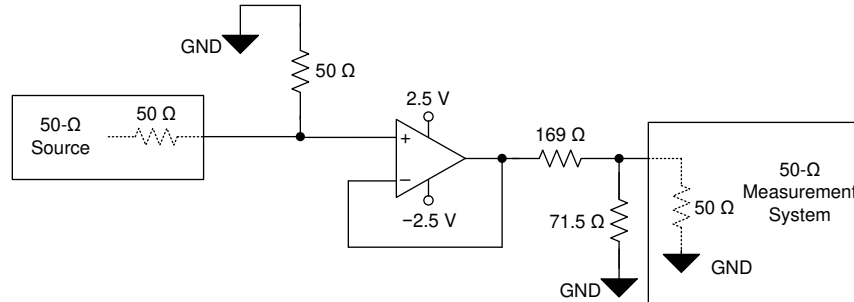


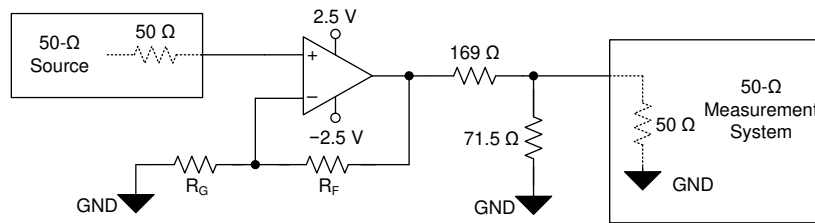
Figure 6-42. Input Bias Current Distribution

## 7 Parameter Measurement Information

The various test setup configurations for the OPA859 are shown in the following figures. When configuring the OPA859 as a noninverting amplifier in gains less than 3 V/V, set  $R_F = 150 \Omega$ . When configuring the OPA859 as a noninverting amplifier in gains of 4 V/V and greater, set  $R_F = 453 \Omega$ .

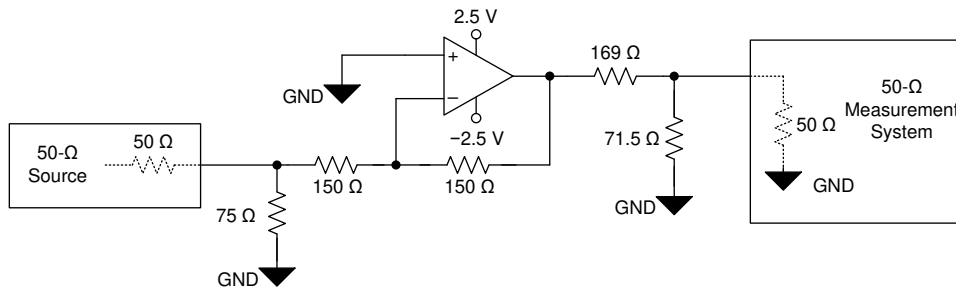


**Figure 7-1. Unity-Gain Buffer Configuration**

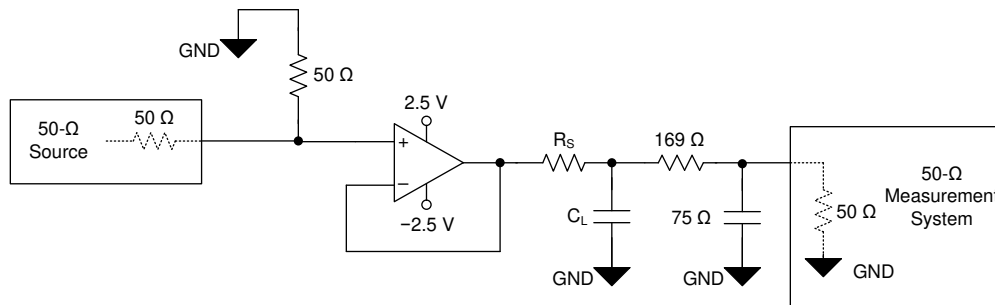


$R_G$  values depend on gain configuration

**Figure 7-2. Noninverting Configuration**



**Figure 7-3. Inverting Configuration (Gain = -1 V/V)**



**Figure 7-4. Capacitive Load Driver Configuration**

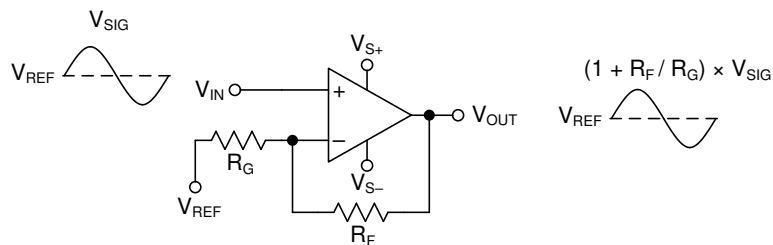
## 8 Detailed Description

### 8.1 Overview

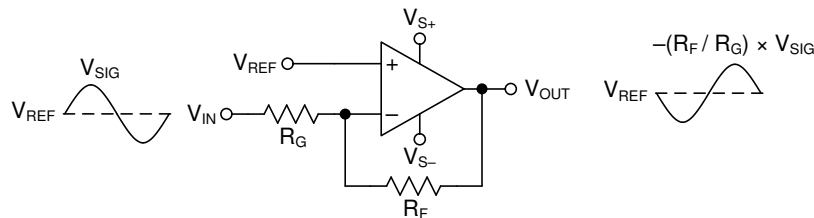
The ultra-wide, 900-MHz gain bandwidth product (GBWP) of the OPA859, combined with the broadband voltage noise of 3.3 nV/ $\sqrt{\text{Hz}}$ , produces a viable amplifier for wideband transimpedance applications, high-speed data acquisition systems, and applications with weak signal inputs that require low-noise and high-gain front ends. The OPA859 combines multiple features to optimize dynamic performance. In addition to the wide small-signal bandwidth, the OPA859 has 400 MHz of large-signal bandwidth ( $V_{\text{OUT}} = 2 V_{\text{PP}}$ ), and a slew rate of 1150 V/ $\mu\text{s}$ .

### 8.2 Functional Block Diagram

The OPA859 is a classic voltage-feedback operational amplifier (op amp) with two high-impedance inputs and a low-impedance output. Standard application circuits are supported, such as the two basic options in [Figure 8-1](#) and [Figure 8-2](#). The dc operating point for each configuration is level-shifted by the reference voltage ( $V_{\text{REF}}$ ), which is typically set to midsupply in single-supply operation.  $V_{\text{REF}}$  is typically connected to ground in split-supply applications.



**Figure 8-1. Noninverting Amplifier**



**Figure 8-2. Inverting Amplifier**

## 8.3 Feature Description

### 8.3.1 Input and ESD Protection

The OPA859 is fabricated on a low-voltage, high-speed, BiCMOS process. The internal, junction breakdown voltages are low for these small geometry devices, and as a result, all device pins are protected with internal ESD protection diodes to the power supplies as [Figure 8-3](#) shows. There are two anti-parallel diodes between the inputs of the amplifier that clamp the inputs during an over-range or fault condition.

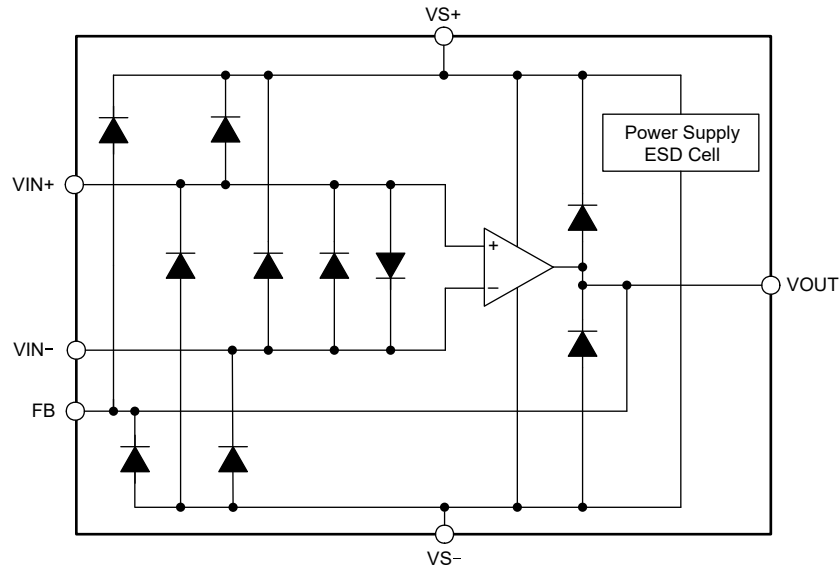


Figure 8-3. Internal ESD Structure

### 8.3.2 Feedback Pin

The OPA859 pin layout is optimized to minimize parasitic inductance and capacitance, which is a critical care about in high-speed analog design. The FB pin (pin 1) is internally connected to the output of the amplifier. The FB pin is separated from the inverting input of the amplifier (pin 3) by a no connect (NC) pin (pin 2). The NC pin must be left floating. There are two advantages to this pin layout:

1. A feedback resistor ( $R_F$ ) can connect between the FB and IN $-$  pin on the same side of the package (see [Figure 8-4](#)) rather than going around the package.
2. The isolation created by the NC pin minimizes the capacitive coupling between the FB and IN $-$  pins by increasing the physical separation between the pins.

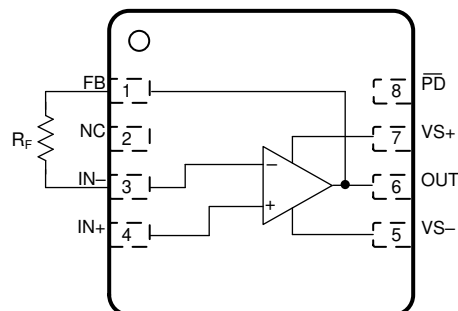
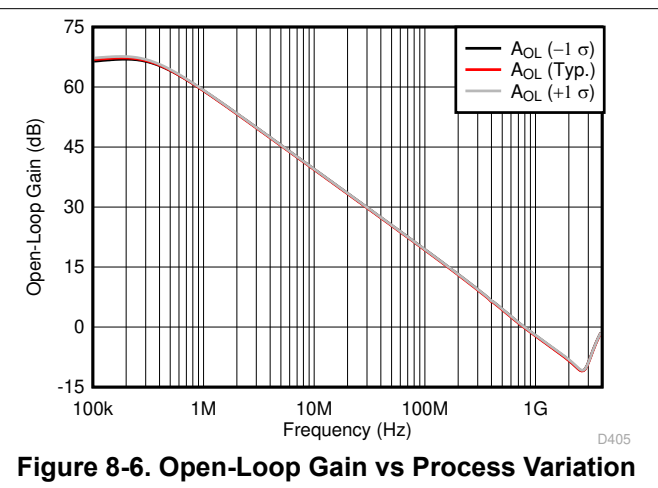
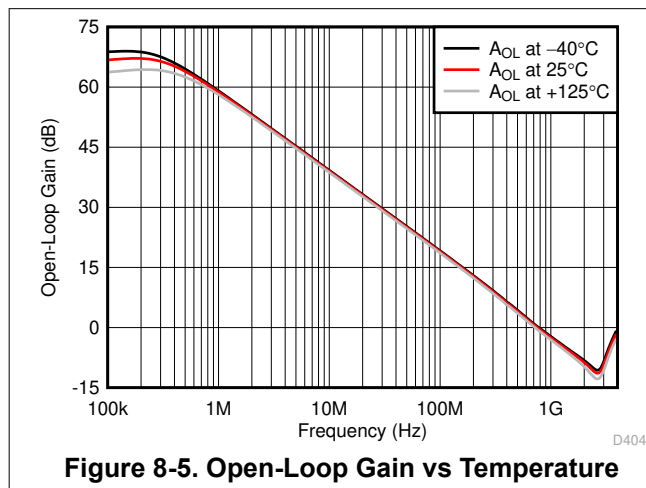


Figure 8-4.  $R_F$  Connection Between FB and IN $-$  Pins

### 8.3.3 Wide Gain-Bandwidth Product

Figure 6-10 shows the open-loop magnitude and phase response of the OPA859. Calculate the gain bandwidth product of any op amp by determining the frequency at which the  $A_{OL}$  is 40 dB and multiplying that frequency by a factor of 100. The open-loop response shows the OPA859 to have approximately  $63^\circ$  of phase-margin when configured as a unity-gain buffer.

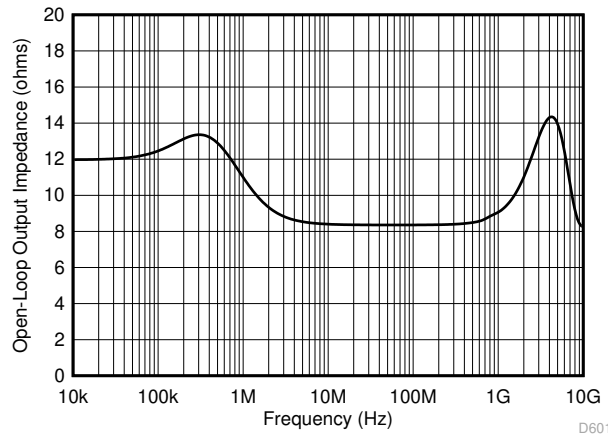
Figure 8-5 shows the open-loop magnitude ( $A_{OL}$ ) of the OPA859 as a function of temperature. The results show approximately  $5^\circ$  of phase-margin variation over the entire temperature range. Semiconductor process variation is the naturally occurring variation in the attributes of a transistor (Early-voltage,  $\beta$ , channel-length, and width) and other passive elements (resistors and capacitors) when fabricated into an integrated circuit. The process variation can occur across devices on a single wafer or across devices over multiple wafer lots over time. Typically the variation across a single wafer is tightly controlled. Figure 8-6 shows the  $A_{OL}$  magnitude of the OPA859 as a function of process variation over time. The results show the  $A_{OL}$  curve for the nominal process corner and the variation one standard deviation from the nominal. The simulated results show less than  $2^\circ$  of phase-margin difference within a standard deviation of process variation when the amplifier is configured as a unity-gain buffer.



### 8.3.4 Slew Rate and Output Stage

In addition to wide bandwidth, the OPA859 features a high slew rate of 1150 V/μs. The slew rate is a critical parameter in high-speed pulse applications with narrow sub-10-ns pulses, such as optical time-domain reflectometry (OTDR) and LIDAR. The high slew rate of the OPA859 implies that the device accurately reproduces a 2-V, sub-ns pulse edge; see also [Figure 6-20](#). The wide bandwidth and slew rate make the OPA859 an excellent amplifier for high-speed signal-chain front ends.

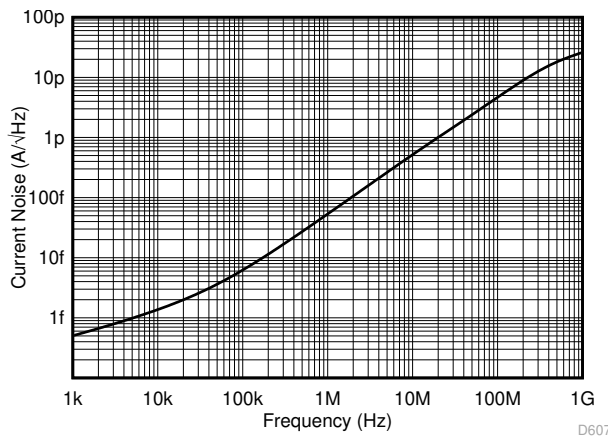
[Figure 8-7](#) shows the open-loop output impedance of the OPA859 as a function of frequency. To achieve high slew rates and low output impedance across frequency, the output swing of the OPA859 is limited to approximately 3 V. The OPA859 is typically used in conjunction with high-speed pipeline ADCs and flash ADCs that have limited input ranges. Therefore, the OPA859 output swing range coupled with the class-leading voltage noise specification for a CMOS amplifier maximizes the overall dynamic range of the signal chain.



**Figure 8-7. Open-Loop Output Impedance ( $Z_{OL}$ ) vs Frequency**

### 8.3.5 Current Noise

The input impedance of CMOS and JFET input amplifiers at low frequencies exceed several GΩs. However, at higher frequencies, the transistors parasitic capacitance to the drain, source, and substrate reduces the impedance. The high impedance at low frequencies eliminates any bias current and the associated shot noise. At higher frequencies, the input current noise increases (see [Figure 8-8](#)) as a result of capacitive coupling between the CMOS gate oxide and the underlying transistor channel. This phenomenon is a natural artifact of the construction of the transistor and is unavoidable.



**Figure 8-8. Input Current Noise ( $I_{BN}$  and  $I_{BI}$ ) vs Frequency**

## 8.4 Device Functional Modes

### 8.4.1 Split-Supply and Single-Supply Operation

The OPA859 can be configured with single-sided supplies or split supplies; see also [Figure 9-4](#). Split-supply operation using balanced supplies with the input common-mode set to ground can help ease lab testing (because most signal generators, network analyzers, spectrum analyzers, and other lab equipment typically reference inputs and outputs to ground). In split-supply operation, connect the thermal pad to the negative supply.

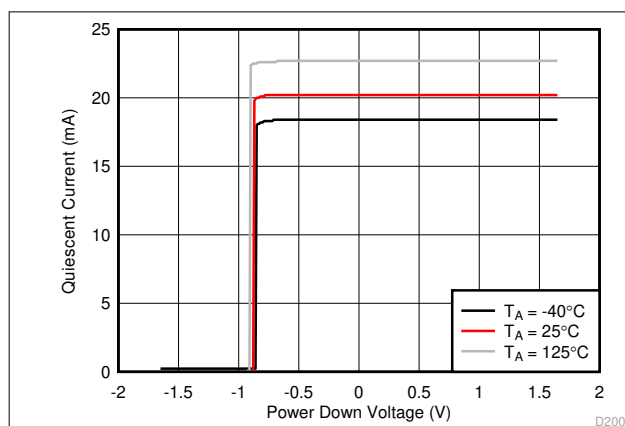
Newer systems use a single power supply to improve efficiency and reduce the cost of the extra power supply. The OPA859 can be used with a single positive supply (negative supply at ground) with no change in performance if the input common-mode and output swing are biased within the linear operation of the device. In single-supply operation, level shift the dc input and output reference voltages by half the difference between the power supply rails. This configuration maintains the input common-mode and output load reference at midsupply. To eliminate gain errors, the source driving the reference input common-mode voltage must have low output impedance across the frequency range of interest. In this case, connect the thermal pad to ground.

### 8.4.2 Power-Down Mode

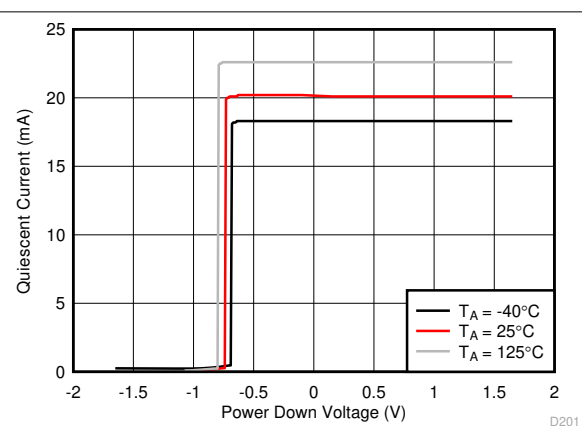
The OPA859 features a power-down mode to reduce the quiescent current to conserve power. and show the OPA859 transient response as the  $\overline{\text{PD}}$  pin toggles between the disabled and enabled states.

The  $\overline{\text{PD}}$  disable and enable threshold voltages are with reference to the negative supply. If the amplifier is configured with the positive supply at 3.3 V and the negative supply at ground, then the disable threshold voltage is 0.65 V and the enable threshold voltage is 1.8 V. If the amplifier is configured with  $\pm 1.65\text{-V}$  supplies, then the disable threshold voltage is  $-1\text{ V}$  and the enable threshold voltage is 0.15 V. If the amplifier is configured with  $\pm 2.5\text{-V}$  supplies, then the disable threshold voltage is  $-1.85\text{ V}$  and the enable threshold voltage is  $-0.7\text{ V}$ .

[Figure 8-9](#) shows the switching behavior of a typical amplifier as the  $\overline{\text{PD}}$  pin is swept down from the enabled to the disabled state. Similarly, [Figure 8-10](#) shows the switching behavior of a typical amplifier as the  $\overline{\text{PD}}$  pin is swept up from the disabled to the enabled state. The small difference in the switching thresholds between the down sweep and up sweep is due to the hysteresis designed into the amplifier to increase noise immunity on  $\overline{\text{PD}}$ .



**Figure 8-9. Switching Threshold  
( $\overline{\text{PD}}$  Pin Swept From High to Low)**



**Figure 8-10. Switching Threshold  
( $\overline{\text{PD}}$  Pin Swept From Low to High)**

Connecting the  $\overline{\text{PD}}$  pin low disables the amplifier and places the output in a high-impedance state. When the amplifier is configured as a noninverting amplifier, the feedback ( $R_F$ ) and gain ( $R_G$ ) resistor network form a parallel load to the output of the amplifier. To protect the input stage of the amplifier, the OPA859 uses internal, back-to-back protection diodes between the inverting and noninverting input pins; see also [Figure 8-3](#). In the power-down state, if the differential voltage between the input pins of the amplifier exceeds a diode voltage drop, an additional low-impedance path is created between the noninverting input pin and the output pin.

## 9 Application and Implementation

### Note

Information in the following applications sections is not part of the TI component specification, and TI does not warrant its accuracy or completeness. TI's customers are responsible for determining suitability of components for their purposes, as well as validating and testing their design implementation to confirm system functionality.

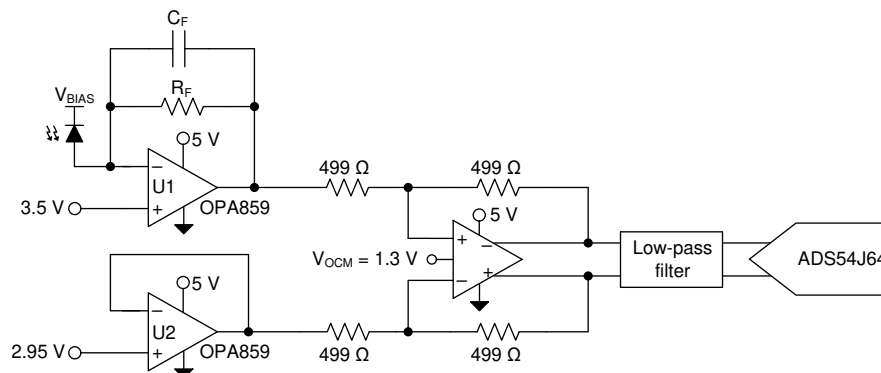
### 9.1 Application Information

The OPA859 offers high input impedance, very high-bandwidth, high slew-rate, low noise, and better than  $-60$  dBc of distortion performance at frequencies up to 100 MHz. These features make this device an excellent front-end buffer in high-speed data acquisition systems. The wide bandwidth also makes this amplifier an excellent choice for high-gain active filter systems.

### 9.2 Typical Applications

#### 9.2.1 TIA in an Optical Front-End System

Figure 9-1 shows the OPA859 configured as a transimpedance amplifier (U1) in a wide-bandwidth, optical front-end system. A second OPA859 configured as a unity-gain buffer (U2) sets a dc offset voltage to the THS4520. The THS4520 is used to convert the single-ended transimpedance output of the OPA859 into a differential output signal. The THS4520 drives the input of the ADS54J64, 14-bit, 1-GSPS analog-to-digital converter (ADC) that digitizes the analog signal.



**Figure 9-1. OPA859 as Both a TIA and a Buffer in an Optical Front-End System**

#### 9.2.1.1 Design Requirements

The objective is to design a low noise, wideband optical front-end system using the OPA859 as a transimpedance amplifier. The design requirements are:

- Amplifier supply voltage: 5 V
- TIA common-mode voltage: 3.5 V
- THS4520 gain: 1 V/V
- ADC input common-mode voltage: 1.3 V
- ADC analog differential input range: 1.1 V<sub>PP</sub>

### 9.2.1.2 Detailed Design Procedure

The OPA859 meets the growing demand for wideband, low-noise photodiode amplifiers. The closed-loop bandwidth of a transimpedance amplifier is a function of the following:

1. The total input capacitance ( $C_{IN}$ ). This total includes the photodiode capacitance, the input capacitance of the amplifier (common-mode and differential capacitance) and any stray capacitance from the PCB.
2. The op amp gain bandwidth product (GBWP).
3. The transimpedance gain ( $R_F$ ).

Figure 9-1 shows the OPA859 configured as a transimpedance amplifier (TIA), with the avalanche photodiode (APD) reverse biased so that the APD cathode is tied to a large positive bias voltage. In this configuration, the APD sources current into the op-amp feedback loop so that the output swings in a negative direction relative to the input common-mode voltage. To maximize the output swing in the negative direction, the common-mode voltage of the OPA859 is set close to the positive limit; only 1.5 V from the positive supply rail. The feedback resistance ( $R_F$ ) and the input capacitance ( $C_{IN}$ ) form a zero in the noise gain that results in instability if left unchecked. To counteract the effect of the zero, a pole is inserted into the noise gain transfer function by adding the feedback capacitor ( $C_F$ ).

The *Transimpedance Considerations for High-Speed Amplifiers Application Report* discusses theories and equations that show how to compensate a transimpedance amplifier for a particular transimpedance gain and input capacitance. The bandwidth and compensation equations from the application report are available in an Excel® calculator. *What You Need To Know About Transimpedance Amplifiers – Part 1* provides a link to the calculator.

The equations and calculators in the referenced application report and blog posts are used to model the bandwidth ( $f_{-3dB}$ ) and noise ( $I_{RN}$ ) performance of the OPA859 configured as a TIA. The resultant performance is shown in Figure 9-2 and Figure 9-3. The left-side Y-axis shows the closed-loop bandwidth performance, whereas the right side of the graph shows the integrated input-referred noise. The noise bandwidth to calculate  $I_{RN}$  for a fixed  $R_F$  and  $C_{PD}$  is set equal to the  $f_{-3dB}$  frequency. Figure 9-2 shows the amplifier performance as a function of photodiode capacitance ( $C_{PD}$ ) for  $R_F = 10\text{ k}\Omega$  and  $20\text{ k}\Omega$ . Increasing  $C_{PD}$  decreases the closed-loop bandwidth. To maximize bandwidth, make sure to reduce any stray parasitic capacitance from the PCB. The OPA859 is designed with 0.8 pF of total input capacitance to minimize the effect of stray capacitance on system performance. Figure 9-3 shows the amplifier performance as a function of  $R_F$  for  $C_{PD} = 1\text{ pF}$  and  $2\text{ pF}$ . Increasing  $R_F$  results in lower bandwidth. To maximize the signal-to-noise ratio (SNR) in an optical front-end system, maximize the gain in the TIA stage. Increasing  $R_F$  by a factor of X increases the signal level by X, but only increases the resistor noise contribution by  $\sqrt{X}$ , thereby improving SNR.

The OPA859 configured as a unity-gain buffer drives a dc offset voltage of 2.95 V into the lower half of the THS4520. To maximize the dynamic range of the ADC, the two OPA859 amplifiers drive a differential common-mode of 3.5 V and 2.95 V into the THS4520. The dc offset voltage of the buffer amplifier can be derived using Equation 1.

$$V_{BUF\_DC} = V_{TIA\_CM} - \left( \frac{1}{2} \times \frac{V_{ADC\_DIFF\_IN}}{\left( \frac{R_F}{R_G} \right)} \right) \quad (1)$$

where

- $V_{TIA\_CM}$  is the common-mode voltage of the TIA (3.5 V)
- $V_{ADC\_DIFF\_IN}$  is the differential input voltage range of the ADC (1.1 V<sub>PP</sub>)
- $R_F$  and  $R_G$  are the feedback resistance (499  $\Omega$ ) and gain resistance (499  $\Omega$ ) of the THS4520 differential amplifier

The low-pass filter between the THS4520 and the ADC54J64 minimizes high-frequency noise and maximizes SNR. The ADC54J64 has an internal buffer that isolates the output of the THS4520 from the ADC sampling-capacitor input, so a traditional charge bucket filter is not required.

### 9.2.1.3 Application Curves

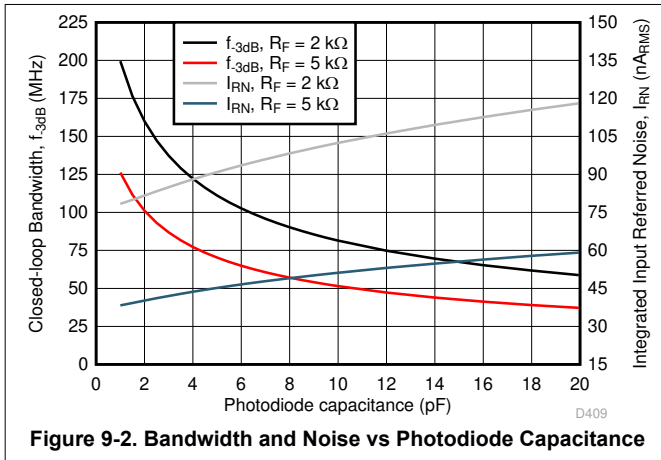


Figure 9-2. Bandwidth and Noise vs Photodiode Capacitance

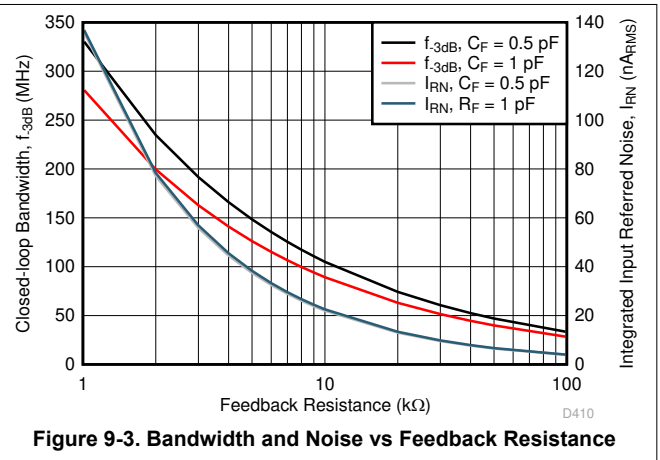
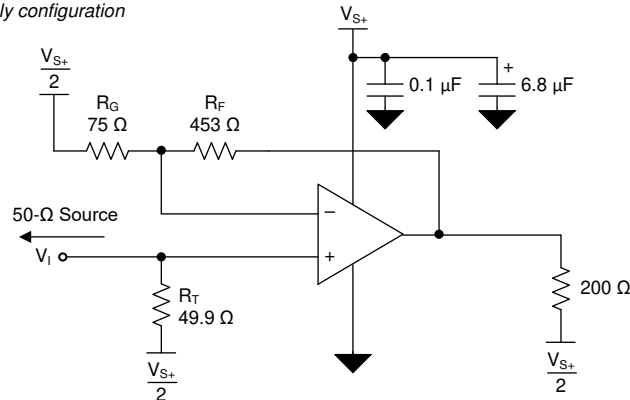


Figure 9-3. Bandwidth and Noise vs Feedback Resistance

### 9.3 Power Supply Recommendations

The OPA859 operates on supplies from 3.3 V to 5.25 V. The OPA859 operates on single-sided supplies, split and balanced bipolar supplies, and unbalanced bipolar supplies. Because the OPA859 does not feature rail-to-rail inputs or outputs, the input common-mode and output swing ranges are limited at 3.3-V supplies.

a) Single supply configuration



b) Split supply configuration

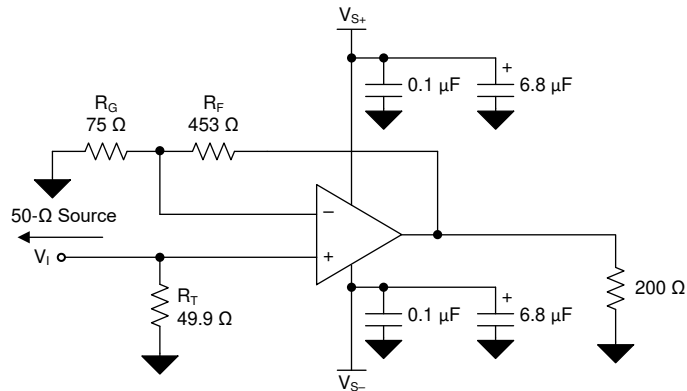


Figure 9-4. Split and Single Supply Circuit Configuration , Gain = 7 V/V

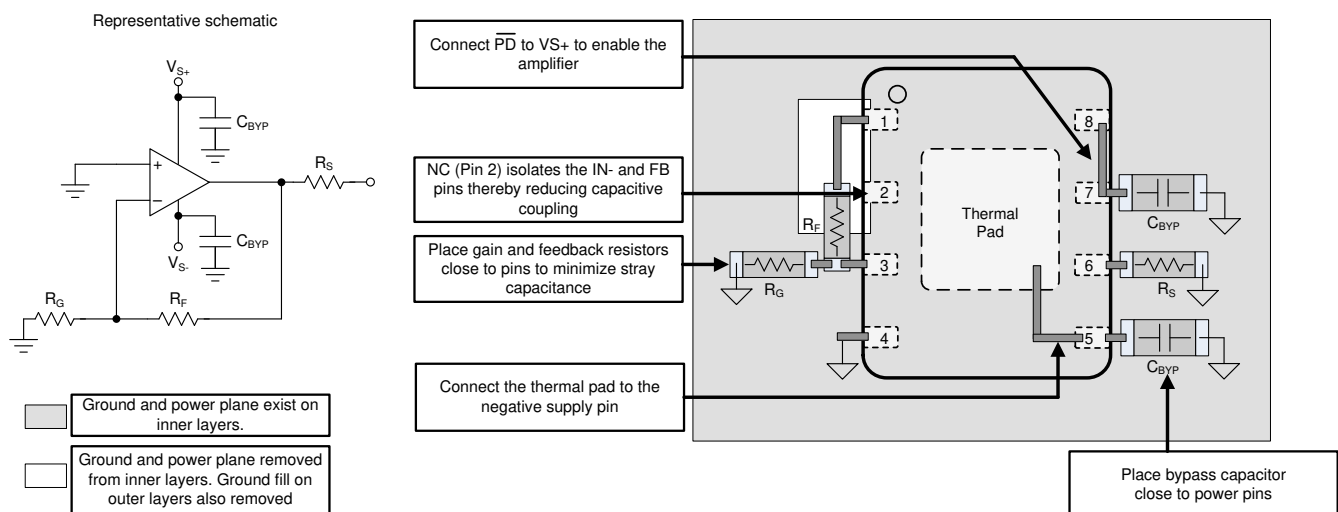
## 9.4 Layout

### 9.4.1 Layout Guidelines

Achieving optimum performance with a high-frequency amplifier like the OPA859 requires careful attention to board layout parasitics and external component types. Recommendations that optimize performance include:

- **Minimize parasitic capacitance from the signal I/O pins to ac ground.** Parasitic capacitance on the output and inverting input pins can cause instability. To reduce unwanted capacitance, cut out the power and ground traces under the signal input and output pins. Otherwise, ground and power planes must be unbroken elsewhere on the board. When configuring the amplifier as a TIA, if the required feedback capacitor is less than 0.15 pF, consider using two series resistors, each of half the value of a single resistor in the feedback loop to minimize the parasitic capacitance from the resistor.
- **Minimize the distance (less than 0.25-in) from the power-supply pins to high-frequency bypass capacitors.** Use high-quality, 100-pF to 0.1- $\mu$ F, C0G and NPO-type decoupling capacitors with voltage ratings at least three times greater than the amplifiers maximum power supplies. This configuration makes sure that there is a low-impedance path to the amplifiers power-supply pins across the amplifiers gain bandwidth specification. At the device pins, do not allow the ground and power plane layout to be in close proximity to the signal I/O pins. Avoid narrow power and ground traces to minimize inductance between the pins and the decoupling capacitors. The power-supply connections must always be decoupled with these capacitors. Larger (2.2- $\mu$ F to 6.8- $\mu$ F) decoupling capacitors that are effective at lower frequency must be used on the supply pins. Place these decoupling capacitors further from the device. Share the decoupling capacitors among several devices in the same area of the printed circuit board (PCB).
- **Careful selection and placement of external components preserves the high-frequency performance of the OPA859.** Use low-reactance resistors. Surface-mount resistors work best and allow a tighter overall layout. Never use wire-wound resistors in a high-frequency application. Because the output pin and inverting input pin are the most sensitive to parasitic capacitance, always position the feedback and series output resistor, if any, as close to the output pin as possible. Place other network components (such as noninverting input termination resistors) close to the package. Even with a low parasitic capacitance shunting the external resistors, high resistor values create significant time constants that can degrade performance. When configuring the OPA859 as a voltage amplifier, keep resistor values as low as possible and consistent with load driving considerations. Decreasing the resistor values keeps the resistor noise terms low and minimizes the effect of the parasitic capacitance. However, lower resistor values increase the dynamic power consumption because  $R_F$  and  $R_G$  become part of the output load network of the amplifier.

### 9.4.2 Layout Example



**Figure 9-5. Layout Recommendation**

## 10 Device and Documentation Support

### 10.1 Device Support

#### 10.1.1 Development Support

- [LIDAR Pulsed Time of Flight Reference Design](#)
- [LIDAR-Pulsed Time-of-Flight Reference Design Using High-Speed Data Converters](#)
- [Wide Bandwidth Optical Front-end Reference Design](#)

### 10.2 Documentation Support

#### 10.2.1 Related Documentation

For related documentation, see the following:

- Texas Instruments, [OPA858EVM user's guide](#)
- Texas Instruments, [Training Video: High-Speed Transimpedance Amplifier Design Flow](#)
- Texas Instruments, [Training Video: How to Design Transimpedance Amplifier Circuits](#)
- Texas Instruments, [Training Video: How to Convert a TINA-TI Model into a Generic SPICE Model](#)
- Texas Instruments, [Transimpedance Considerations for High-Speed Amplifiers application report](#)
- Texas Instruments, [What You Need To Know About Transimpedance Amplifiers – Part 1](#)
- Texas Instruments, [What You Need To Know About Transimpedance Amplifiers – Part 2](#)

### 10.3 Receiving Notification of Documentation Updates

To receive notification of documentation updates, navigate to the device product folder on [ti.com](http://ti.com). Click on *Notifications* to register and receive a weekly digest of any product information that has changed. For change details, review the revision history included in any revised document.

### 10.4 Support Resources

[TI E2E™ support forums](#) are an engineer's go-to source for fast, verified answers and design help — straight from the experts. Search existing answers or ask your own question to get the quick design help you need.

Linked content is provided "AS IS" by the respective contributors. They do not constitute TI specifications and do not necessarily reflect TI's views; see TI's [Terms of Use](#).

### 10.5 Trademarks

TI E2E™ is a trademark of Texas Instruments.

Excel® is a registered trademark of Microsoft Corporation.

All trademarks are the property of their respective owners.

### 10.6 Electrostatic Discharge Caution



This integrated circuit can be damaged by ESD. Texas Instruments recommends that all integrated circuits be handled with appropriate precautions. Failure to observe proper handling and installation procedures can cause damage.

ESD damage can range from subtle performance degradation to complete device failure. Precision integrated circuits may be more susceptible to damage because very small parametric changes could cause the device not to meet its published specifications.

### 10.7 Glossary

[TI Glossary](#) This glossary lists and explains terms, acronyms, and definitions.

## 11 Revision History

### Changes from Revision \* (September 2018) to Revision A (May 2025)

Page

- |  |   |
|--|---|
| • Added bare die package and associated content to data sheet..... | 1 |
|--|---|

## 12 Mechanical, Packaging, and Orderable Information

The following pages include mechanical, packaging, and orderable information. This information is the most current data available for the designated devices. This data is subject to change without notice and revision of this document. For browser-based versions of this data sheet, refer to the left-hand navigation.

**PACKAGING INFORMATION**

Orderable part number	Status (1)	Material type (2)	Package   Pins	Package qty   Carrier	RoHS (3)	Lead finish/ Ball material (4)	MSL rating/ Peak reflow (5)	Op temp (°C)	Part marking (6)
<a href="#">OPA859IDSGR</a>	Active	Production	WSON (DSG)   8	3000   LARGE T&R	Yes	SN	Level-1-260C-UNLIM	-40 to 125	859
OPA859IDSGR.B	Active	Production	WSON (DSG)   8	3000   LARGE T&R	Yes	SN	Level-1-260C-UNLIM	-40 to 125	859
<a href="#">OPA859IDSGT</a>	Active	Production	WSON (DSG)   8	250   SMALL T&R	Yes	SN	Level-1-260C-UNLIM	-40 to 125	859
OPA859IDSGT.B	Active	Production	WSON (DSG)   8	250   SMALL T&R	Yes	SN	Level-1-260C-UNLIM	-40 to 125	859
<a href="#">OPA859YR</a>	Active	Production	DIESALE (Y)   0	3000   LARGE T&R	Yes	Call TI	N/A for Pkg Type	-40 to 125	

(1) **Status:** For more details on status, see our [product life cycle](#).

(2) **Material type:** When designated, preproduction parts are prototypes/experimental devices, and are not yet approved or released for full production. Testing and final process, including without limitation quality assurance, reliability performance testing, and/or process qualification, may not yet be complete, and this item is subject to further changes or possible discontinuation. If available for ordering, purchases will be subject to an additional waiver at checkout, and are intended for early internal evaluation purposes only. These items are sold without warranties of any kind.

(3) **RoHS values:** Yes, No, RoHS Exempt. See the [TI RoHS Statement](#) for additional information and value definition.

(4) **Lead finish/Ball material:** Parts may have multiple material finish options. Finish options are separated by a vertical ruled line. Lead finish/Ball material values may wrap to two lines if the finish value exceeds the maximum column width.

(5) **MSL rating/Peak reflow:** The moisture sensitivity level ratings and peak solder (reflow) temperatures. In the event that a part has multiple moisture sensitivity ratings, only the lowest level per JEDEC standards is shown. Refer to the shipping label for the actual reflow temperature that will be used to mount the part to the printed circuit board.

(6) **Part marking:** There may be an additional marking, which relates to the logo, the lot trace code information, or the environmental category of the part.

Multiple part markings will be inside parentheses. Only one part marking contained in parentheses and separated by a "-" will appear on a part. If a line is indented then it is a continuation of the previous line and the two combined represent the entire part marking for that device.

**Important Information and Disclaimer:** The information provided on this page represents TI's knowledge and belief as of the date that it is provided. TI bases its knowledge and belief on information provided by third parties, and makes no representation or warranty as to the accuracy of such information. Efforts are underway to better integrate information from third parties. TI has taken and continues to take reasonable steps to provide representative and accurate information but may not have conducted destructive testing or chemical analysis on incoming materials and chemicals. TI and TI suppliers consider certain information to be proprietary, and thus CAS numbers and other limited information may not be available for release.

In no event shall TI's liability arising out of such information exceed the total purchase price of the TI part(s) at issue in this document sold by TI to Customer on an annual basis.

**OTHER QUALIFIED VERSIONS OF OPA859 :**

- Automotive : [OPA859-Q1](#)

## NOTE: Qualified Version Definitions:

- Automotive - Q100 devices qualified for high-reliability automotive applications targeting zero defects

**TAPE AND REEL INFORMATION**

**QUADRANT ASSIGNMENTS FOR PIN 1 ORIENTATION IN TAPE**


\*All dimensions are nominal

Device	Package Type	Package Drawing	Pins	SPQ	Reel Diameter (mm)	Reel Width W1 (mm)	A0 (mm)	B0 (mm)	K0 (mm)	P1 (mm)	W (mm)	Pin1 Quadrant
OPA859IDSGR	WSON	DSG	8	3000	180.0	8.4	2.3	2.3	1.15	4.0	8.0	Q2
OPA859IDSGT	WSON	DSG	8	250	180.0	8.4	2.3	2.3	1.15	4.0	8.0	Q2
OPA859YR	DIESALE	Y	0	3000	180.0	8.4	0.74	0.78	0.45	4.0	8.0	Q1

**TAPE AND REEL BOX DIMENSIONS**


\*All dimensions are nominal

Device	Package Type	Package Drawing	Pins	SPQ	Length (mm)	Width (mm)	Height (mm)
OPA859IDSGR	WSON	DSG	8	3000	210.0	185.0	35.0
OPA859IDSGT	WSON	DSG	8	250	210.0	185.0	35.0
OPA859YR	DIESALE	Y	0	3000	210.0	185.0	35.0

## GENERIC PACKAGE VIEW

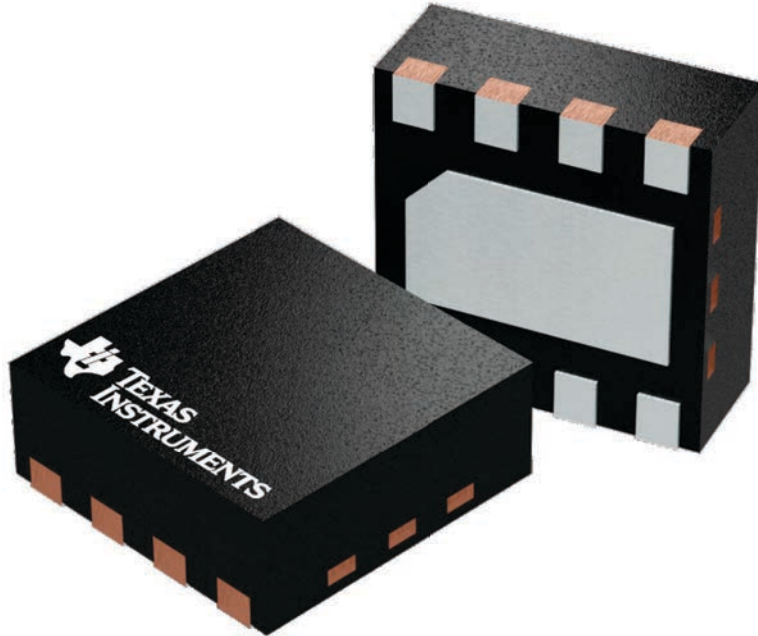
**DSG 8**

**WSON - 0.8 mm max height**

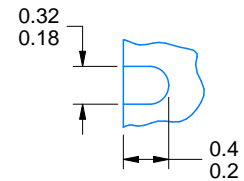
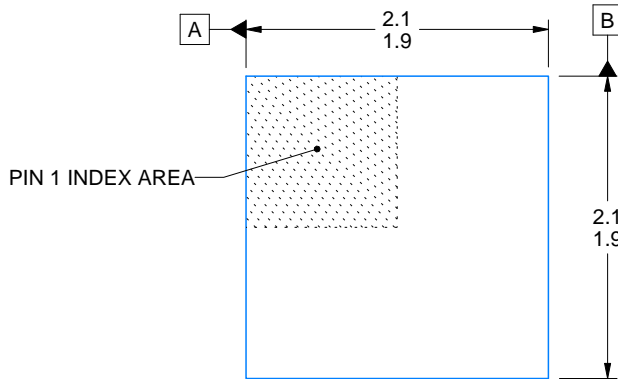
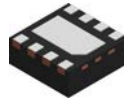
2 x 2, 0.5 mm pitch

PLASTIC SMALL OUTLINE - NO LEAD

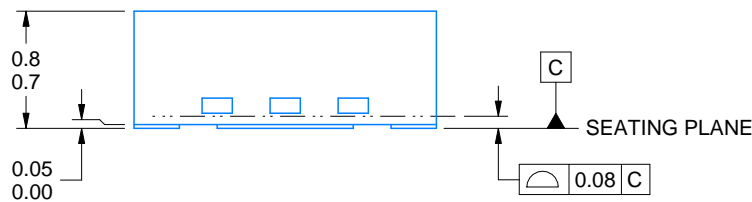
This image is a representation of the package family, actual package may vary.  
Refer to the product data sheet for package details.



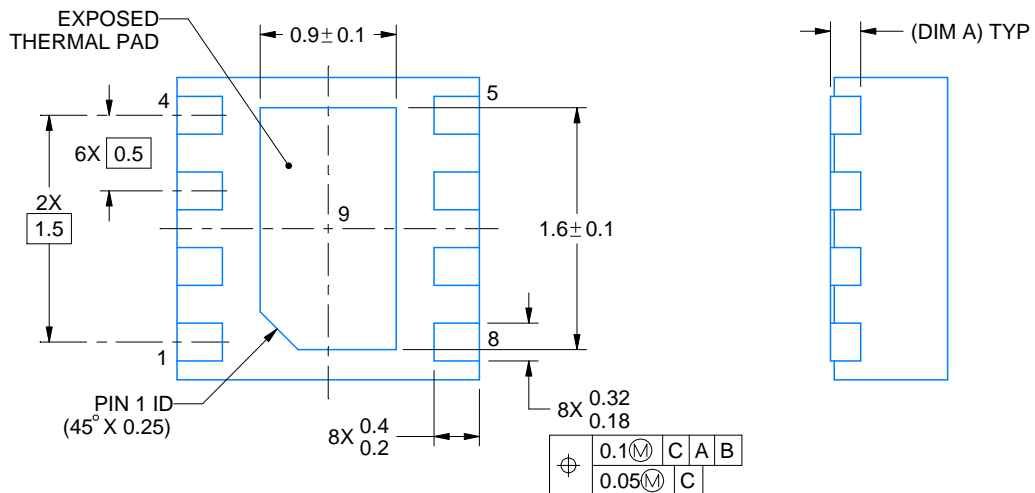
4224783/A



ALTERNATIVE TERMINAL SHAPE TYPICAL



SIDE WALL METAL THICKNESS DIM A	
OPTION 1	OPTION 2
0.1	0.2



4218900/E 08/2022

NOTES:

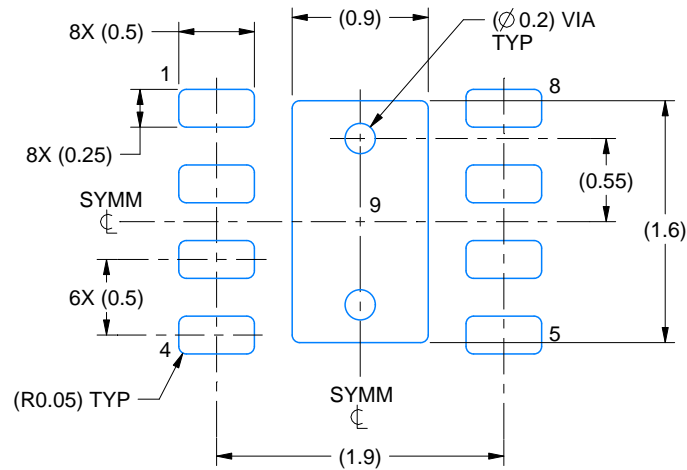
1. All linear dimensions are in millimeters. Any dimensions in parenthesis are for reference only. Dimensioning and tolerancing per ASME Y14.5M.
2. This drawing is subject to change without notice.
3. The package thermal pad must be soldered to the printed circuit board for thermal and mechanical performance.

# EXAMPLE BOARD LAYOUT

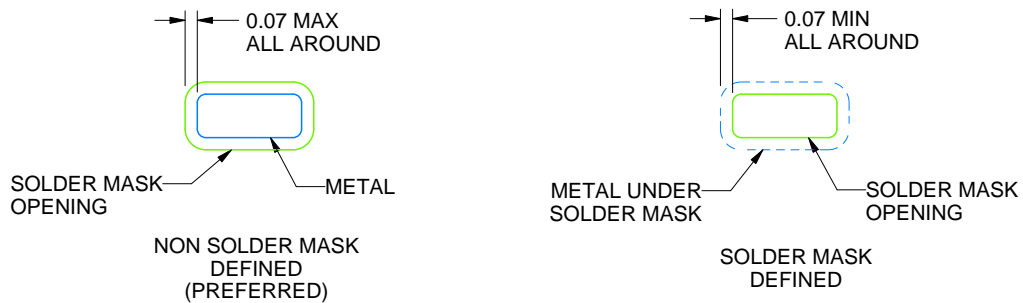
DSG0008A

WSON - 0.8 mm max height

PLASTIC SMALL OUTLINE - NO LEAD



LAND PATTERN EXAMPLE  
SCALE:20X



SOLDER MASK DETAILS

4218900/E 08/2022

NOTES: (continued)

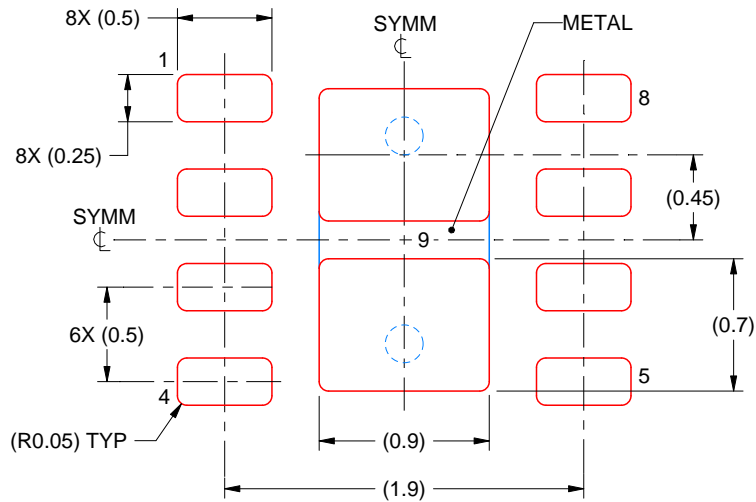
4. This package is designed to be soldered to a thermal pad on the board. For more information, see Texas Instruments literature number SLUA271 ([www.ti.com/lit/slua271](http://www.ti.com/lit/slua271)).
5. Vias are optional depending on application, refer to device data sheet. If any vias are implemented, refer to their locations shown on this view. It is recommended that vias under paste be filled, plugged or tented.

# EXAMPLE STENCIL DESIGN

DSG0008A

WSON - 0.8 mm max height

PLASTIC SMALL OUTLINE - NO LEAD



SOLDER PASTE EXAMPLE  
BASED ON 0.125 mm THICK STENCIL

EXPOSED PAD 9:  
87% PRINTED SOLDER COVERAGE BY AREA UNDER PACKAGE  
SCALE:25X

4218900/E 08/2022

NOTES: (continued)

6. Laser cutting apertures with trapezoidal walls and rounded corners may offer better paste release. IPC-7525 may have alternate design recommendations.

## IMPORTANT NOTICE AND DISCLAIMER

TI PROVIDES TECHNICAL AND RELIABILITY DATA (INCLUDING DATASHEETS), DESIGN RESOURCES (INCLUDING REFERENCE DESIGNS), APPLICATION OR OTHER DESIGN ADVICE, WEB TOOLS, SAFETY INFORMATION, AND OTHER RESOURCES "AS IS" AND WITH ALL FAULTS, AND DISCLAIMS ALL WARRANTIES, EXPRESS AND IMPLIED, INCLUDING WITHOUT LIMITATION ANY IMPLIED WARRANTIES OF MERCHANTABILITY, FITNESS FOR A PARTICULAR PURPOSE OR NON-INFRINGEMENT OF THIRD PARTY INTELLECTUAL PROPERTY RIGHTS.

These resources are intended for skilled developers designing with TI products. You are solely responsible for (1) selecting the appropriate TI products for your application, (2) designing, validating and testing your application, and (3) ensuring your application meets applicable standards, and any other safety, security, regulatory or other requirements.

These resources are subject to change without notice. TI grants you permission to use these resources only for development of an application that uses the TI products described in the resource. Other reproduction and display of these resources is prohibited. No license is granted to any other TI intellectual property right or to any third party intellectual property right. TI disclaims responsibility for, and you fully indemnify TI and its representatives against any claims, damages, costs, losses, and liabilities arising out of your use of these resources.

TI's products are provided subject to [TI's Terms of Sale](#), [TI's General Quality Guidelines](#), or other applicable terms available either on [ti.com](http://ti.com) or provided in conjunction with such TI products. TI's provision of these resources does not expand or otherwise alter TI's applicable warranties or warranty disclaimers for TI products. Unless TI explicitly designates a product as custom or customer-specified, TI products are standard, catalog, general purpose devices.

TI objects to and rejects any additional or different terms you may propose.

Copyright © 2026, Texas Instruments Incorporated

Last updated 10/2025