

SN6505x Low-Noise 1-A Transformer Drivers for Isolated Power Supplies

1 Features

- Push-pull driver for transformers
- Wide input voltage range: 2.25 V to 5.5 V
- High output drive: 1 A at 5 V supply
- Low R_{ON} 0.25 Ω max at 4.5 V supply
- Ultra-low EMI
- Spread spectrum clocking
- Precision internal oscillator options: 160 kHz (SN6505A) and 420 kHz (SN6505B)
- Synchronization of multiple devices with external clock input
- Slew-rate control
- 1.7 A Current-limit
- Low shutdown current: <1 μ A
- Thermal shutdown
- Wide temperature range: -55°C to 125°C
- Small 6-Pin SOT23 (DBV) package
- Soft-start to reduce In-rush current

2 Applications

- Isolated power supply for CAN, RS-485, RS-422, RS-232, SPI, I2C, low-power LAN
- Low-noise isolated USB supplies
- Process control
- Telecom supplies
- Radio supplies
- Distributed supplies
- Medical instruments
- Precision instruments
- Low-noise filament supplies

3 Description

The SN6505x is a low-noise, low-EMI push-pull transformer driver, specifically designed for small form factor, isolated power supplies. It drives low-profile, center-tapped transformers from a 2.25 V to 5 V DC power supply. Ultra-low noise and EMI are achieved by slew rate control of the output switch voltage and through Spread Spectrum Clocking (SSC). The SN6505x consists of an oscillator followed by a gate drive circuit that provides the complementary output signals to drive ground-referenced N-channel power switches. The device includes two 1-A Power-MOSFET switches to ensure start-up under heavy loads. The switching clock can also be provided externally for accurate placement of switcher harmonics, or when operating with multiple transformer drivers. The internal protection features include a 1.7 A current limiting, under-voltage lockout, thermal shutdown, and break-before-make circuitry. SN6505x includes a soft-start feature that prevents high inrush current during power up with large load capacitors. SN6505A has a 160 kHz internal oscillator for applications that need to minimize emissions whereas SN6505B has a 420 kHz internal oscillators for applications that require higher efficiency and smaller transformer size. The SN6505x is available in a small 6-pin SOT23/DBV package. The device operation is characterized for a temperature range from -55°C to 125°C .

Device Information

| PART NUMBER | PACKAGE | BODY SIZE (NOM) |
|-------------|---------------|-------------------|
| SN6505A | SOT23 (6 Pin) | 2.90 mm × 1.60 mm |
| SN6505B | | |

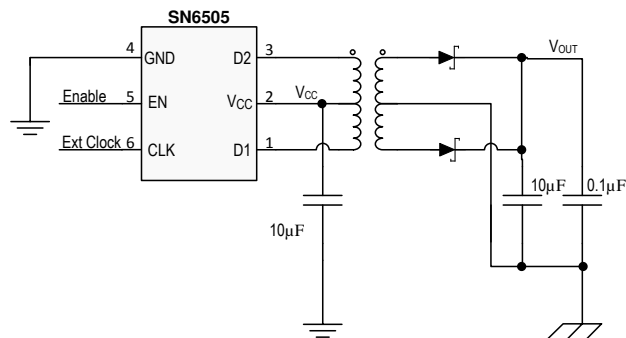

Copyright © 2016, Texas Instruments Incorporated

Simplified Schematic



Table of Contents

| | | | |
|--|----|--|----|
| 1 Features | 1 | 8.3 Feature Description..... | 18 |
| 2 Applications | 1 | 8.4 Device Functional Modes..... | 20 |
| 3 Description | 1 | 9 Application and Implementation | 21 |
| 4 Revision History | 2 | 9.1 Application Information..... | 21 |
| 5 Pin Configuration and Functions | 3 | 9.2 Typical Application..... | 22 |
| 6 Specifications | 4 | 10 Power Supply Recommendations | 33 |
| 6.1 Absolute Maximum Ratings..... | 4 | 11 Layout | 34 |
| 6.2 ESD Ratings..... | 4 | 11.1 Layout Guidelines..... | 34 |
| 6.3 Recommended Operating Conditions..... | 4 | 11.2 Layout Example..... | 34 |
| 6.4 Thermal Information..... | 4 | 12 Device and Documentation Support | 35 |
| 6.5 Electrical Characteristics..... | 5 | 12.1 Device Support..... | 35 |
| 6.6 Timing Requirements..... | 6 | 12.2 Documentation Support..... | 35 |
| 6.7 Typical Characteristics, SN6505A | 7 | 12.3 Related Links..... | 35 |
| 6.8 Typical Characteristics, SN6505B | 9 | 12.4 Receiving Notification of Documentation Updates.. | 35 |
| 7 Parameter Measurement Information | 16 | 12.5 Community Resources..... | 35 |
| 8 Detailed Description | 18 | 12.6 Trademarks..... | 35 |
| 8.1 Overview..... | 18 | 13 Mechanical, Packaging, and Orderable Information | 35 |
| 8.2 Functional Block Diagram..... | 18 | | |

4 Revision History

| Changes from Revision H (July 2019) to Revision I (August 2023) | Page |
|---|------|
| • Section 6.8 , added new graphs..... | 9 |
| • Added new transformers to Table 9-3 | 28 |
| Changes from Revision G (November 2018) to Revision H (July 2019) | Page |
| • Added HCT-SM-1.3-8-2 transformer to Table 9-3 | 28 |
| • Added EPC3668G-LF transformer to Table 9-3 table..... | 28 |
| • Added DA2303-AL transformer to Table 9-3 table..... | 28 |
| • Added DA2304-AL transformer to Table 9-3 | 28 |
| Changes from Revision F (September 2016) to Revision G (November 2018) | Page |
| • Made editorial corrections and modifications throughout the document | 1 |
| • Added Section 8.4.1.1 description in Section 8.4 section | 20 |
| • Changed 3 V to 2.25 V in the description of Section 9.2.2.1 section | 22 |
| • Changed Schottky diode RB168M-40 to RB168MM-40 in Section 9.2.2.3 section..... | 23 |
| • Changed f_{min} to 138 kHz for SN6505A and 363 kHz for SN6505B in Section 9.2.2.5.1 section and updated Equation 4 | 25 |
| • Changed load current, V_{DO-max} , V_{O-max} , R_{DS-max} and I_{D-max} values and updated Equation 11 in Section 9.2.2.5.2 Example | 25 |
| • Changed LDO from 'No' to 'Yes' for transformer ORDER NO. 750313638 and 750313626 in Table 9-3 | 28 |
| • Updated Figure 9-9 | 31 |
| • Changed the <i>Electrostatic Discharge Caution</i> statement..... | 35 |
| Changes from Revision E (August 2016) to Revision F (September 2016) | Page |
| • Changed text From: "connected as possible" To: "connected as close as possible" in Section 10 | 33 |
| Changes from Revision D (August 2016) to Revision E (August 2016) | Page |
| • Changed Table 9-3 , and added Note 1..... | 28 |
| Changes from Revision C (August 2016) to Revision D (August 2016) | Page |
| • Section 6.7 , added Figure 6-1 and Figure 6-2 back into the datasheet | 7 |

- [Section 6.7](#), added [Figure 6-9](#) to [Figure 6-47](#) back into the datasheet 7
- [Section 6.8](#), added [Figure 6-11](#) and [Figure 6-12](#) back into the data sheet 9
- [Section 6.8](#), added [Figure 6-45](#) and [Figure 6-46](#) back into the data sheet 9
- Changed [Table 9-3](#) 28

Changes from Revision B (February 2016) to Revision C (August 2016) Page

- Changed the [Section 6.7](#) section..... 7
- Added the [Section 6.8](#) section..... 9
- Changed [Table 9-3](#) 28

Changes from Revision A (October 2015) to Revision B (February 2016) Page

- Changed the [Section 6.4](#) table From: 16 Pin DW (SOIC) To: 6 Pin DBV (SOT-23) 4

Changes from Revision * (September 2015) to Revision A (October 2015) Page

- Production Release 1

5 Pin Configuration and Functions

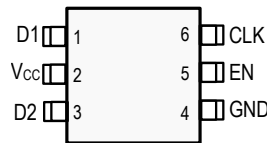

Figure 5-1. DBV Package SOT-23 (6 Pin) Top View

Table 5-1. Pin Functions

| PIN | | | DESCRIPTION |
|-----------------|-----|------|--|
| NAME | NO. | TYPE | |
| D1 | 1 | O | Open drain output of the first power MOSFETs. Typically connected to the outer terminals of the center tap transformer. Because large currents flow through these pins, their external traces should be kept short. |
| V _{CC} | 2 | P | This is the device supply pin. It should be bypassed with a 4.7 μF or greater, low ESR capacitor. When V _{CC} ≤ 2.25 V, an internal undervoltage lockout circuit trips and turns both outputs off. |
| D2 | 3 | O | Open drain output of the second power MOSFETs. Typically connected to the outer terminals of the center tap transformer. Because large currents flow through these pins, their external traces should be kept short. |
| GND | 4 | P | GND is connected to the source of the power MOSFET switches via an internal sense circuit. Because large currents flow through it, the GND terminals must be connected to a low-inductance quality ground plane. |
| EN | 5 | I | The EN pin turns the device on or off. Grounding or leaving this pin floating disables all internal circuitry. If unused this pin should be tied directly to V _{CC} . |
| CLK | 6 | I | This pin is used to run the device with external clock. Internally it is pulled down to GND. If valid clock is not detected on this pin, the device shifts automatically to internal clock. |

6 Specifications

6.1 Absolute Maximum Ratings

over operating free-air temperature range (unless otherwise noted)⁽¹⁾. All typical values are at $T_A = 25^\circ\text{C}$, $V_{CC} = 5\text{ V}$.

| | | MIN | MAX | UNIT |
|--------------------------------------|-----------------------------|------|-------------------------------|------------------|
| Supply voltage ⁽²⁾ | V_{CC} | -0.5 | 6 | V |
| Voltage | EN, CLK | -0.5 | $V_{CC} + 0.5$ ⁽³⁾ | |
| Output switch voltage | D1, D2 | | 16 | V |
| Peak output switch current | $I_{(D1)Pk}$, $I_{(D2)Pk}$ | | 2.4 | A |
| Junction temperature, T_J | | -55 | 150 | $^\circ\text{C}$ |
| Storage temperature range, T_{stg} | | -65 | 150 | $^\circ\text{C}$ |

- (1) Stresses beyond those listed under Absolute Maximum Ratings cause permanent damage to the device. These are stress ratings only and functional operation of the device at these or any other conditions beyond those indicated under [Section 6.3](#) is not implied. Exposure to absolute-maximum-rated conditions for extended periods affects device reliability.
- (2) All voltage values except differential I/O bus voltages are with respect to the local ground terminal (GND) and are peak voltage values.
- (3) Maximum voltage of 6V.

6.2 ESD Ratings

| | | | VALUE | UNIT |
|-------------|-------------------------|--|------------|------|
| $V_{(ESD)}$ | Electrostatic discharge | Human body model (HBM), per ANSI/ESDA/JEDEC JS-001, all pins ⁽¹⁾ | ± 6000 | V |
| | | Charged device model (CDM), per JEDEC specification JESD22-C101, all pins ⁽²⁾ | ± 1500 | |

- (1) JEDEC document JEP155 states that 500-V HBM allows safe manufacturing with a standard ESD control process.
- (2) JEDEC document JEP157 states that 250-V CDM allows safe manufacturing with a standard ESD control process.

6.3 Recommended Operating Conditions

| | | MIN | TYP | MAX | UNIT |
|---------------------|--------------------------------------|---|-----|------|------------------|
| V_{CC} | Supply voltage | 2.25 | | 5.5 | V |
| I_{D1} , I_{D2} | Output switch current - Primary side | $2.25\text{ V} < V_{CC} < 2.8\text{ V}$ | | 0.75 | A |
| | | $2.8\text{ V} < V_{CC} < 5.5\text{ V}$ | | 1 | |
| T_A | Ambient temperature | -55 | | 125 | $^\circ\text{C}$ |

6.4 Thermal Information

| THERMAL METRIC ⁽¹⁾ | | SN6505 | UNIT |
|-------------------------------|--|--------------|---------------------------|
| | | DBV (SOT-23) | |
| | | 6 PINS | |
| $R_{\theta JA}$ | Junction-to-ambient thermal resistance | 137.7 | $^\circ\text{C}/\text{W}$ |
| $R_{\theta JC(top)}$ | Junction-to-case (top) thermal resistance | 57.7 | $^\circ\text{C}/\text{W}$ |
| $R_{\theta JB}$ | Junction-to-board thermal resistance | 46.0 | $^\circ\text{C}/\text{W}$ |
| Ψ_{JT} | Junction-to-top characterization parameter | 13.4 | $^\circ\text{C}/\text{W}$ |
| Ψ_{JB} | Junction-to-board characterization parameter | 44.9 | $^\circ\text{C}/\text{W}$ |
| $R_{\theta JC(bottom)}$ | Junction-to-case(bottom) thermal resistance | N/A | $^\circ\text{C}/\text{W}$ |

- (1) For more information about traditional and new thermal metrics, see the [Semiconductor and IC Package Thermal Metrics application report](#).

6.5 Electrical Characteristics

over full-range of recommended operating conditions, unless otherwise noted. All typical values are at $T_A = 25^\circ\text{C}$, $V_{CC} = 5\text{ V}$.

| PARAMETER | | TEST CONDITIONS | MIN | TYP | MAX | UNIT |
|--------------------------------|---|--|------|------|------|------------------|
| VOLTAGE SUPPLY | | | | | | |
| $I_{(V_{CC})}$ | Supply Current ($2.8\text{ V} < V_{CC} < 5.5$) (SN6505A) | $R_L = 50\ \Omega$ | | 1 | 1.4 | mA |
| | Supply Current ($2.8\text{ V} < V_{CC} < 5.5$) (SN6505B) | $R_L = 50\ \Omega$ | | 1.56 | 2.3 | mA |
| I_{IH} | Leakage Current on EN and CLK pin | $EN / CLK = V_{CC}$ | | 10 | 20 | μA |
| I_{DIS} | V_{CC} current for EN = 0 | | | 0.1 | | μA |
| $I_{LKG(D1)}$ $I_{LKG(D2)}$ | Leakage Current on D1,D2 for EN=0 | Voltage of D1,D2 = V_{CC} | | 0.1 | | μA |
| $V_{CC+ (UVLO)}$ | Positive-going UVLO threshold | | | | 2.25 | V |
| $V_{CC- (UVLO)}$ | Negative-going UVLO threshold | | 1.7 | | | V |
| $V_{HYS (UVLO1)}$ | UVLO threshold hysteresis | | | 0.3 | | V |
| $V_{IN(ON)}$ | EN, CLK pin logic high threshold | | | | 0.7 | V_{CC} |
| $V_{IN(OFF)}$ | EN, CLK pin logic low threshold | | 0.3 | | | V_{CC} |
| $V_{IN(HYS)}$ | EN, CLK pin threshold hysteresis | | | 0.2 | | V_{CC} |
| CLK | | | | | | |
| F_{SW} | D1, D2 average switching Frequency (SN6505A) | $R_L = 50\ \Omega$ to V_{CC} ; Refer to Figure 7-3 | 138 | 160 | 203 | Khz |
| | D1, D2 average switching Frequency (SN6505B) | $R_L = 50\ \Omega$ to V_{CC} ; Refer to Figure 7-3 . | 363 | 424 | 517 | kHz |
| $F_{(EXT)}$ | External clock frequency on CLK pin (SN6505A) | | 100 | | 600 | kHz |
| | External clock frequency on CLK pin (SN6505B) | | 100 | | 1600 | kHz |
| OUTPUT STAGE | | | | | | |
| DMM | Average ON time mismatch between D1 and D2 | $R_L = 50\ \Omega$ | | 0% | | |
| $R_{(ON)}$ | Output switch on resistance | $V_{CC} = 4.5\text{ V}$, $ID1, ID2 = 1\text{ A}$ | | 0.16 | 0.25 | Ω |
| | | $V_{CC} = 2.8\text{ V}$, $ID1, ID2 = 1\text{ A}$ | | 0.19 | 0.31 | Ω |
| | | $V_{CC} = 2.25\text{ V}$, $ID1, ID2 = 0.5\text{ A}$ | | 0.21 | 0.45 | Ω |
| $V_{(SLEW)}$ | Voltage slew rates on D1 and D2 for SN6505A | $R_L = 50\ \Omega$ to V_{CC} ; Refer to Figure 7-3 | | 48 | | V/ μs |
| $I_{(SLEW)}$ | Current slew rates at D1 and D2 for SN6505A | $R_L = 5\ \Omega$ through transformer; Refer to Figure 7-4 | | 11 | | A/ μs |
| $V_{(SLEWHF)}$ | Voltage slew rates on D1 and D2 for SN6505B | $R_L = 50\ \Omega$ to V_{CC} ; Refer to Figure 7-3 | | 152 | | V/ μs |
| $I_{(SLEWHF)}$ | Current slew rates at D1 and D2 for SN6505B | $R_L = 5\ \Omega$ through transformer; Refer to Figure 7-4 | | 41 | | A/ μs |
| I_{LIM} | Current clamp limit ($2.8\text{ V} < V_{CC} < 5.5\text{ V}$) | | 1.42 | 1.75 | 2.15 | A |
| | Current clamp limit ($2.25\text{ V} < V_{CC} < 2.8\text{ V}$) | | 0.65 | | 1.85 | A |
| THERMAL SHUT DOWN | | | | | | |
| T_{SD+} | T_{SD} turn on temperature | | 154 | 168 | 181 | $^\circ\text{C}$ |
| T_{SD-} | T_{SD} turn off temperature | | 135 | 150 | 166 | $^\circ\text{C}$ |
| T_{SD-} | T_{SD} hysteresis | | 13 | 17 | | $^\circ\text{C}$ |

6.6 Timing Requirements

| | | | MIN | NOM | MAX | UNIT |
|-----------------------|--|--|-----|------|-----|---------------|
| CLK | | | | | | |
| t_{CLKTIMER} | Duration after which device switches to internal clock in case of invalid external clock | | 10 | | 25 | μs |
| OUTPUT STAGE | | | | | | |
| t_{BBM} | Break-before-make time (SN6505A) | Measured as voltage with $R_L = 50 \Omega$ to V_{CC} , Refer to Figure 7-3 | | 115 | | ns |
| | Break-before-make time (SN6505B) | Measured as voltage with $R_L = 50 \Omega$ to V_{CC} , Refer to Figure 7-3 | | 90 | | ns |
| SOFT-START | | | | | | |
| t_{SS} | Soft-start time | 10% to 90% transition time on V_{OUT} With transformer $C_{\text{LOAD}} = 40 \mu\text{F}$ $R_L = 5 \Omega$ | 1 | 4.25 | 8 | ms |
| t_{SSdelay} | Soft-start time delay | From power up to 90% transition time on V_{OUT} With transformer $C_{\text{LOAD}} = 40 \mu\text{F}$ $R_L = 5 \Omega$ | 3.5 | 8.5 | 18 | ms |

6.7 Typical Characteristics, SN6505A

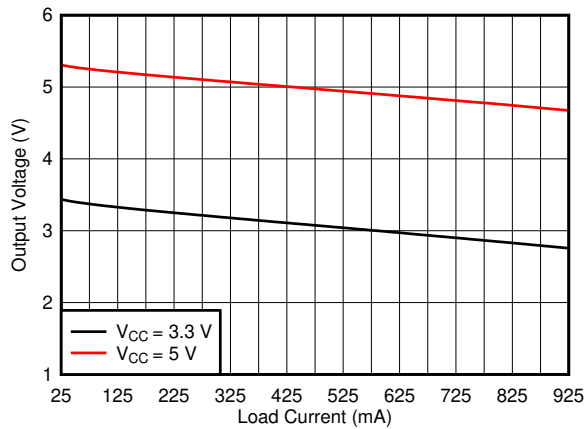

SN6505A + Würth 750315240

Figure 6-1. Output Voltage vs Load Current

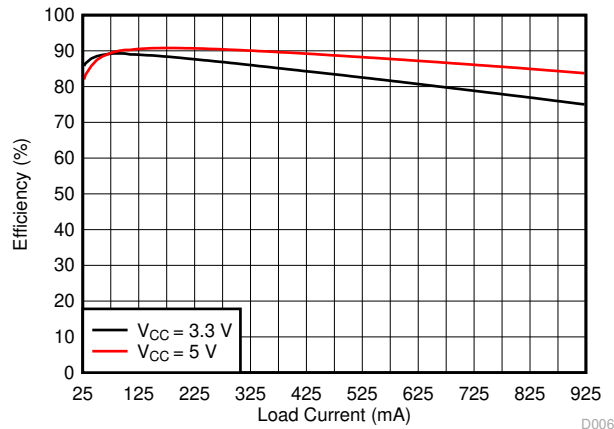

SN6505A + Würth 750315240

Figure 6-2. Efficiency vs Load Current



SN6505A + Würth 750316031 V_{CC} = 3.3 V

Figure 6-3. Output Voltage vs Load Current

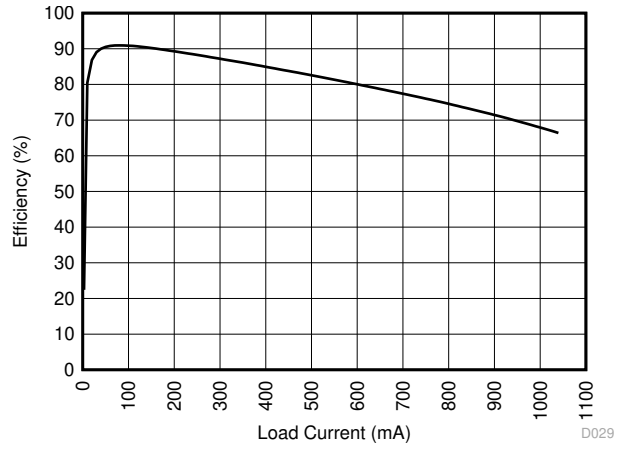

SN6505A + Würth 750316031 V_{CC} = 3.3 V

Figure 6-4. Efficiency vs Load Current

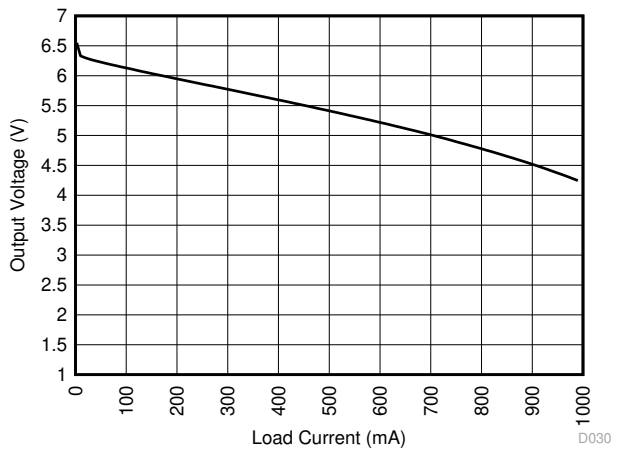

SN6505A + Würth 750316032 V_{CC} = 3.3 V

Figure 6-5. Output Voltage vs Load Current

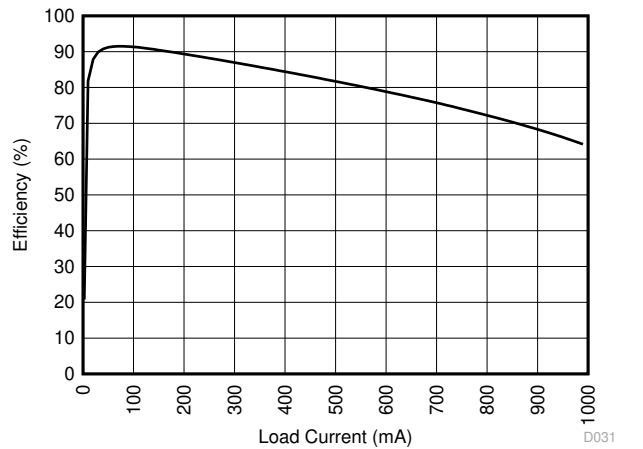

SN6505A + Würth 750316032 V_{CC} = 3.3 V

Figure 6-6. Efficiency vs Load Current

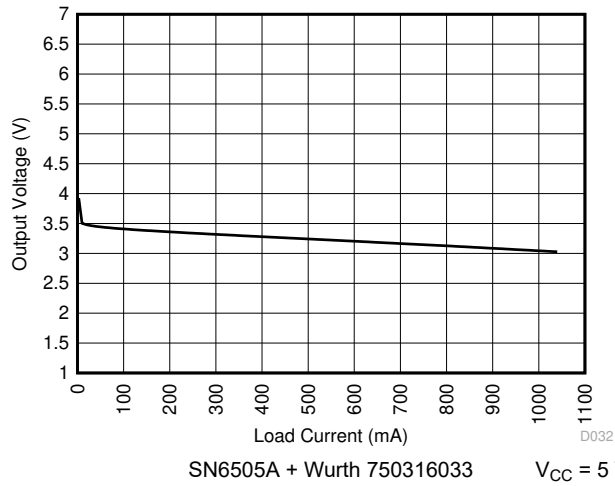

Figure 6-7. Output Voltage vs Load Current

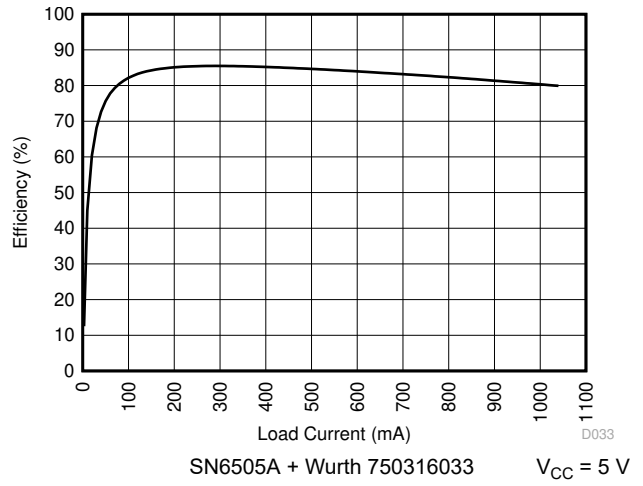

Figure 6-8. Efficiency vs Load Current

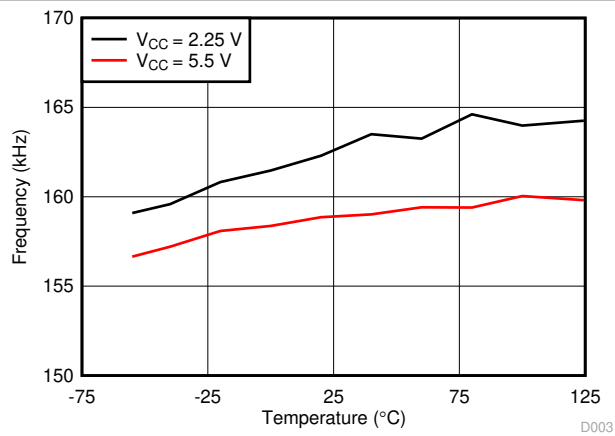

Figure 6-9. Frequency vs Free-Air Temperature

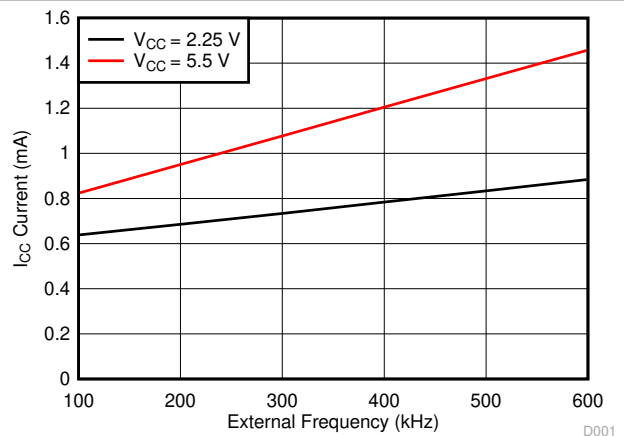

Figure 6-10. Current vs External Frequency

6.8 Typical Characteristics, SN6505B

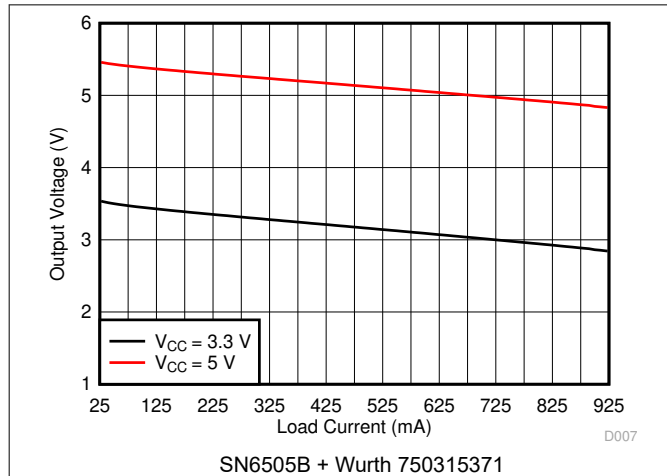

Figure 6-11. Output Voltage vs Load Current

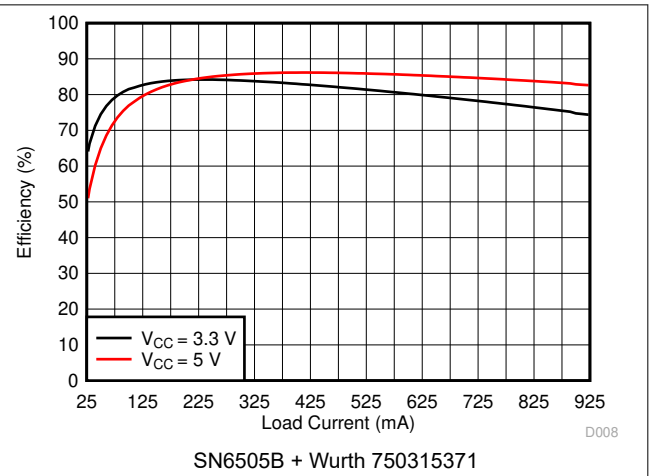

Figure 6-12. Efficiency vs Load Current

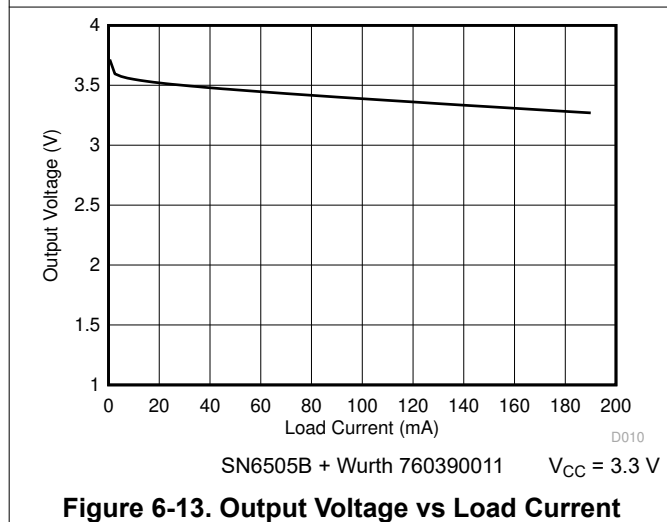

Figure 6-13. Output Voltage vs Load Current

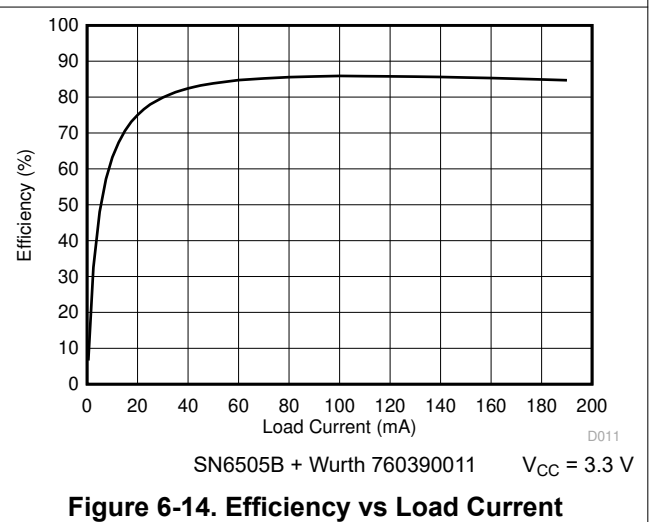

Figure 6-14. Efficiency vs Load Current

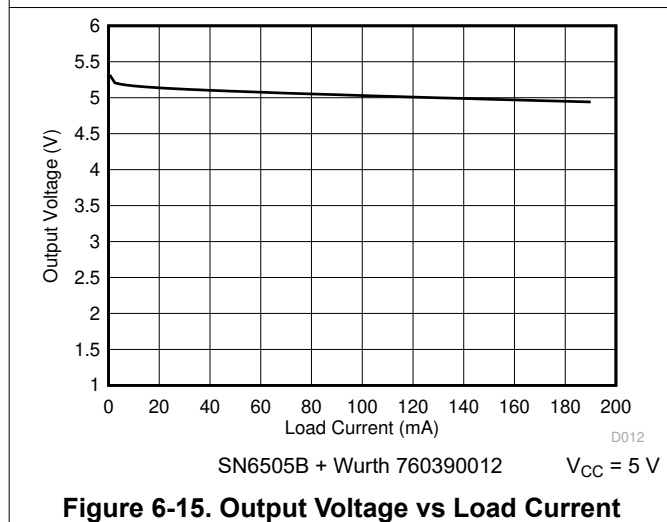

Figure 6-15. Output Voltage vs Load Current

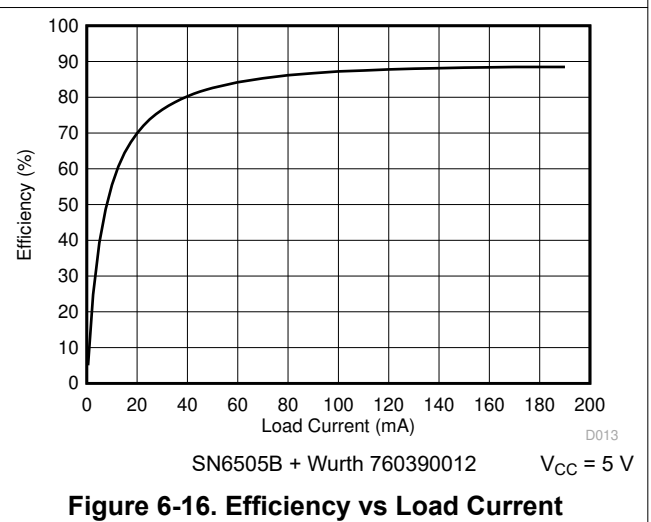
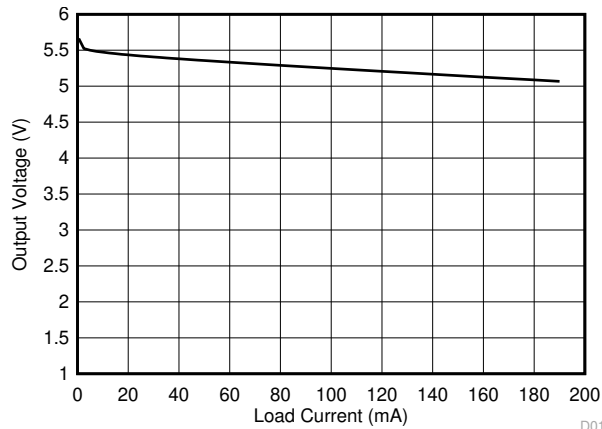
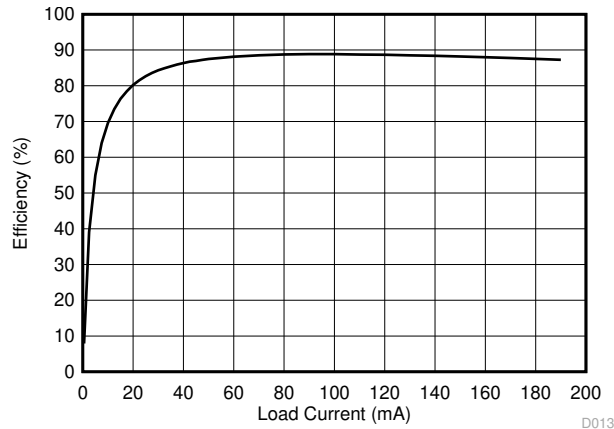

Figure 6-16. Efficiency vs Load Current



SN6505B + Würth 760390013 $V_{CC} = 3.3\text{ V}$

Figure 6-17. Output Voltage vs Load Current



SN6505B + Würth 760390013 $V_{CC} = 3.3\text{ V}$

Figure 6-18. Efficiency vs Load Current

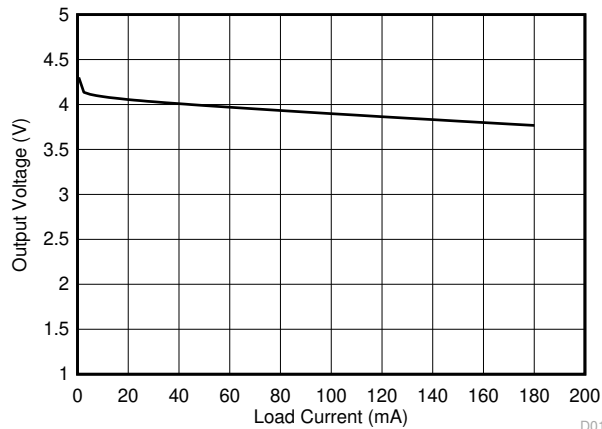

SN6505B + Würth 760390014 $V_{CC} = 3.3\text{ V}$

Figure 6-19. Output Voltage vs Load Current

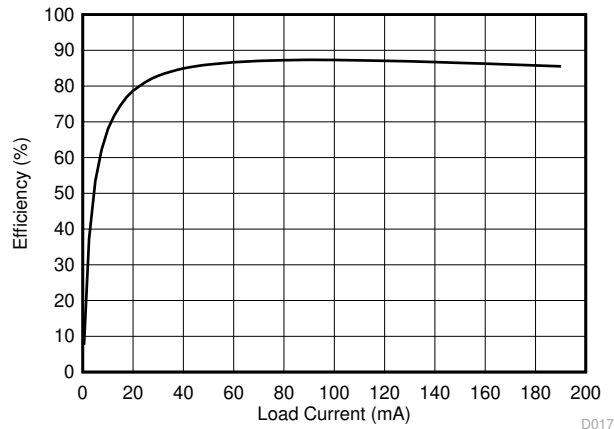

SN6505B + Würth 760390014 $V_{CC} = 3.3\text{ V}$

Figure 6-20. Efficiency vs Load Current

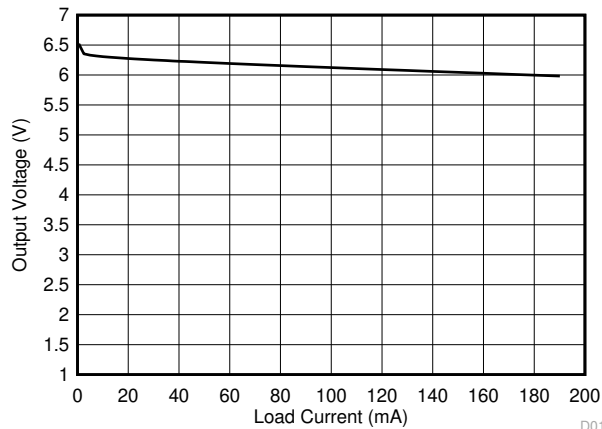

SN6505B + Würth 760390014 $V_{CC} = 5\text{ V}$

Figure 6-21. Output Voltage vs Load Current

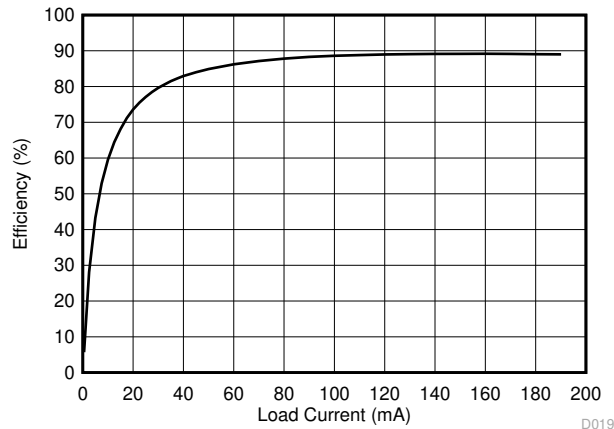

SN6505B + Würth 760390014 $V_{CC} = 5\text{ V}$

Figure 6-22. Efficiency vs Load Current

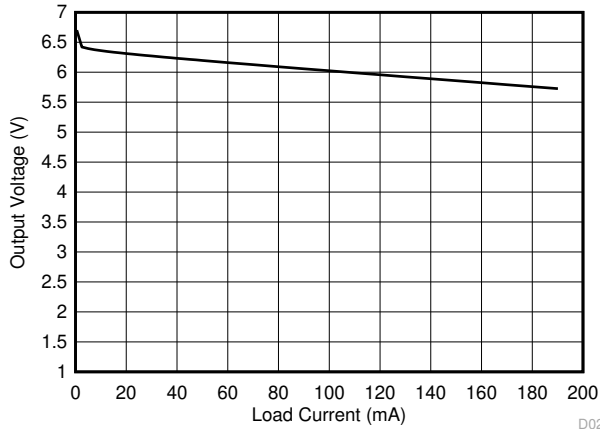

SN6505B + Würth 760390015 $V_{CC} = 3.3\text{ V}$

Figure 6-23. Output Voltage vs Load Current

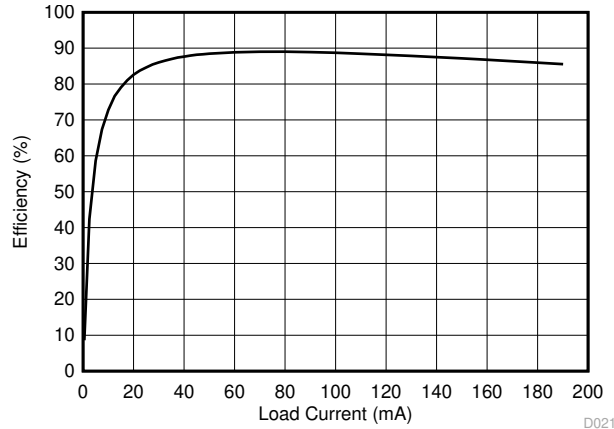

SN6505B + Würth 760390015 $V_{CC} = 3.3\text{ V}$

Figure 6-24. Efficiency vs Load Current

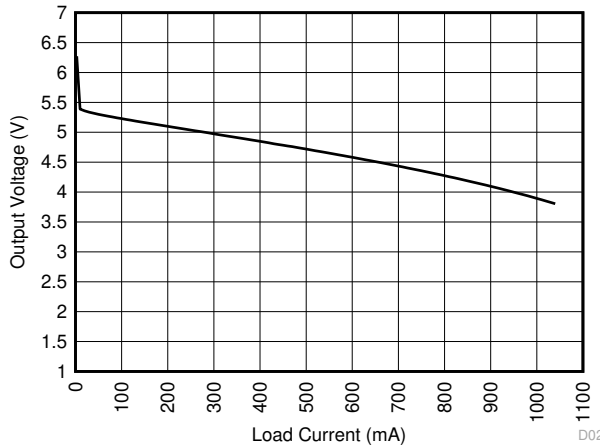

SN6505B + Würth 750316028 $V_{CC} = 3.3\text{ V}$

Figure 6-25. Output Voltage vs Load Current



SN6505B + Würth 750316028 $V_{CC} = 3.3\text{ V}$

Figure 6-26. Efficiency vs Load Current

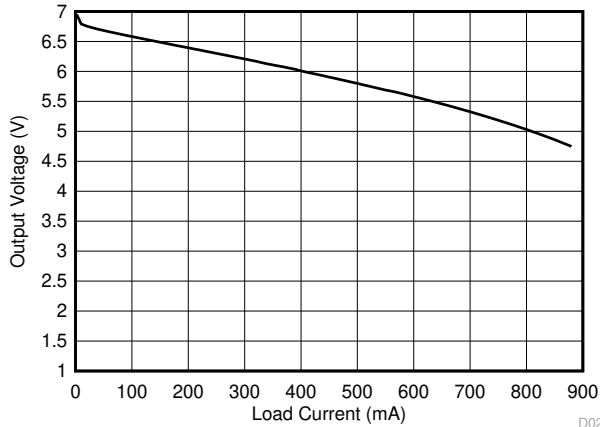

SN6505B + Würth 750316029 $V_{CC} = 3.3\text{ V}$

Figure 6-27. Output Voltage vs Load Current

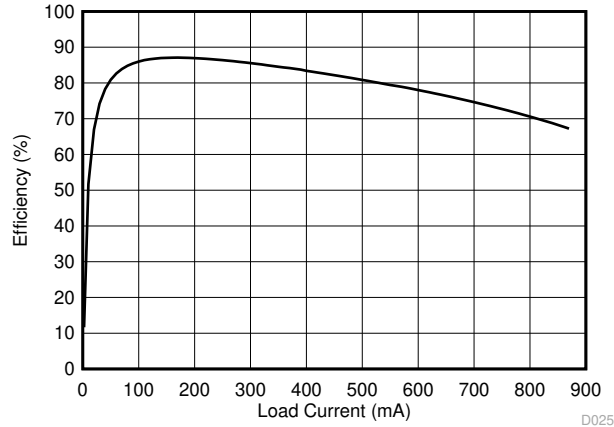

SN6505B + Würth 750316029 $V_{CC} = 3.3\text{ V}$

Figure 6-28. Efficiency vs Load Current

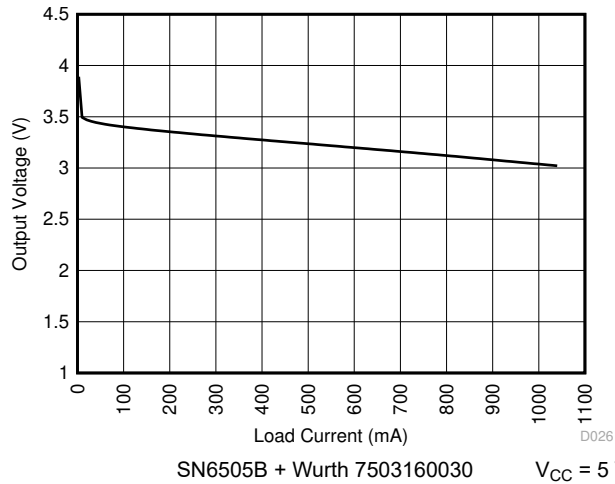

Figure 6-29. Output Voltage vs Load Current

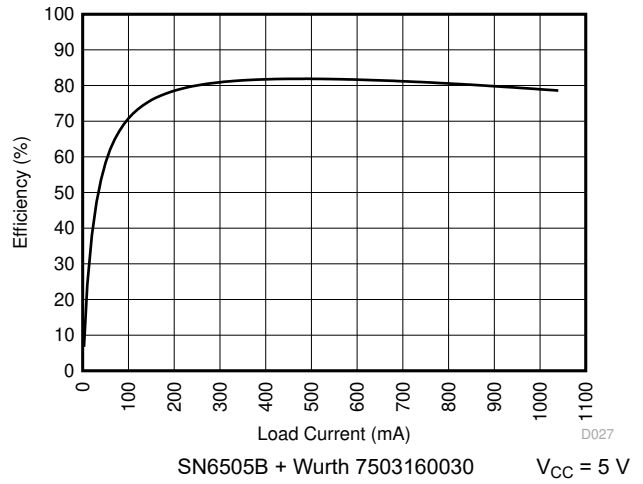

Figure 6-30. Efficiency vs Load Current

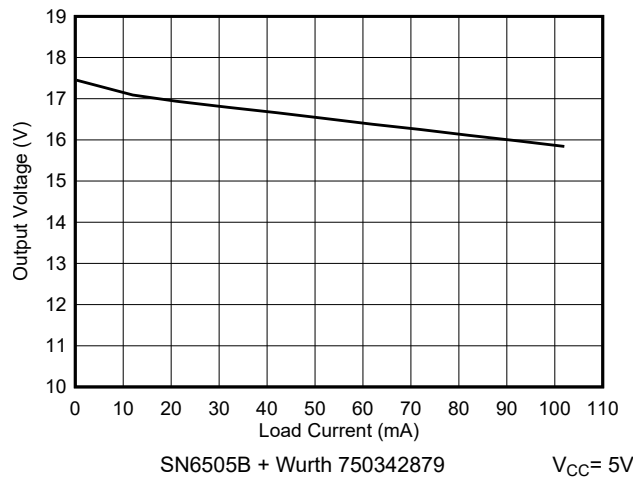

Figure 6-31. Output Voltage vs Load Current

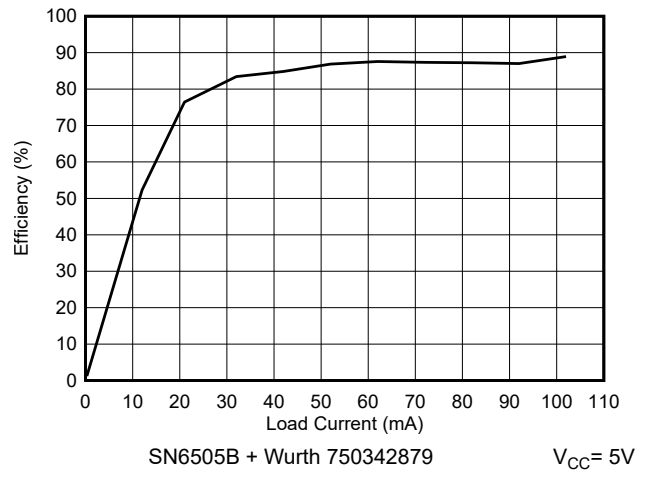

Figure 6-32. Efficiency vs Load Current

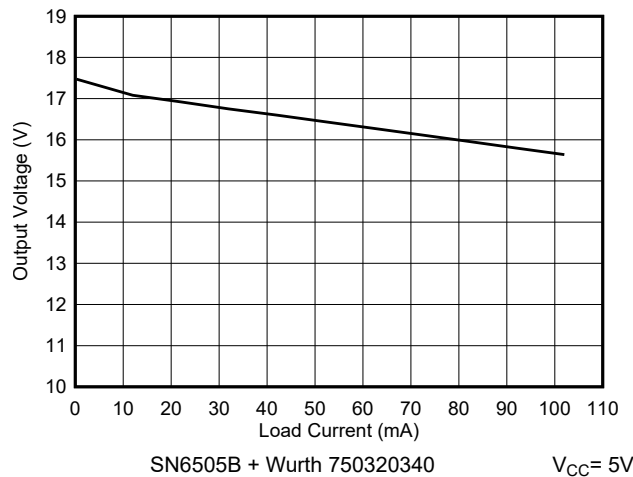

Figure 6-33. Output Voltage vs Load Current

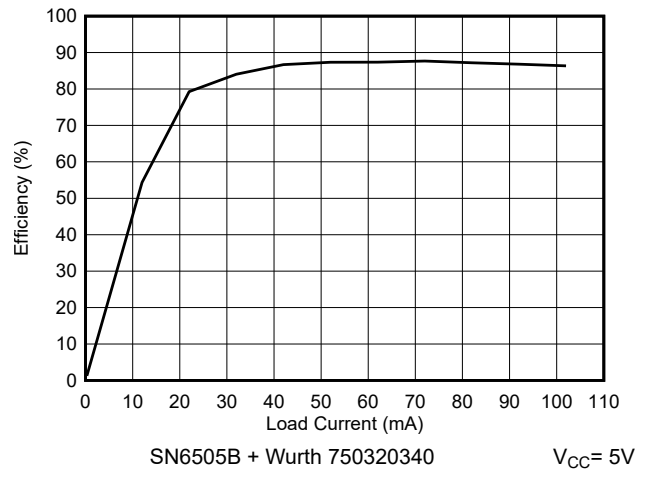

Figure 6-34. Efficiency vs Load Current

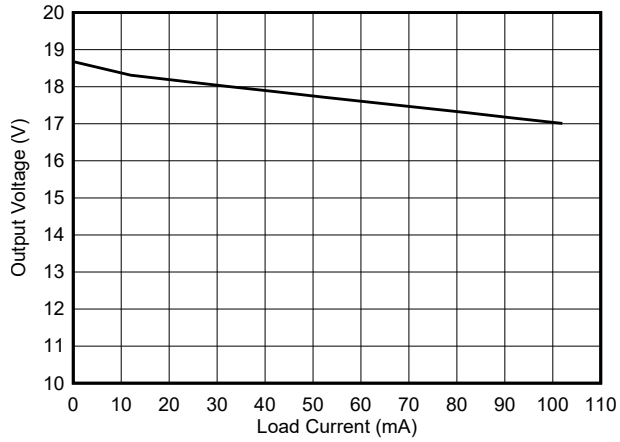

Figure 6-35. Output Voltage vs Load Current

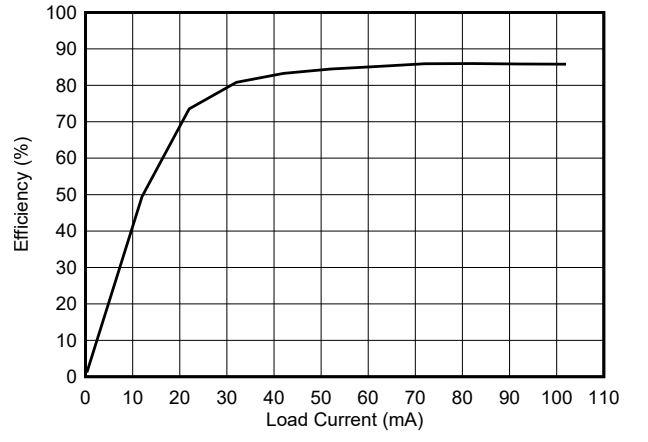

Figure 6-36. Efficiency vs Load Current

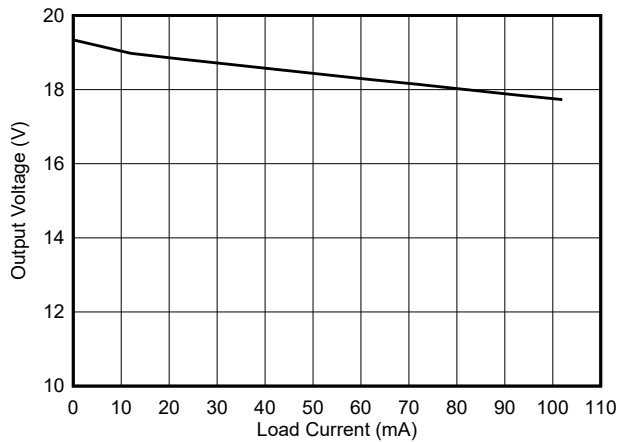

Figure 6-37. Output Voltage vs Load Current

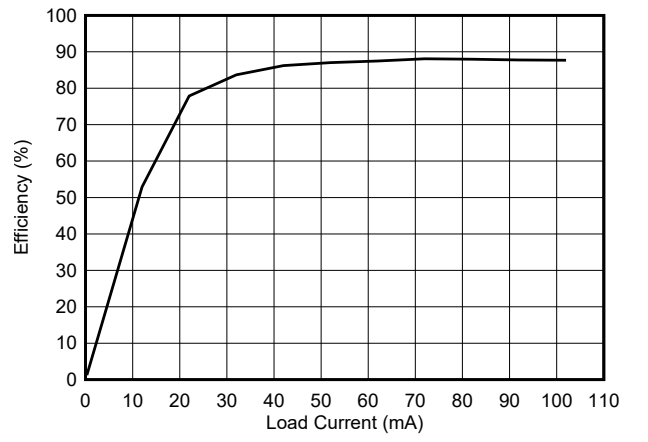

Figure 6-38. Efficiency vs Load Current

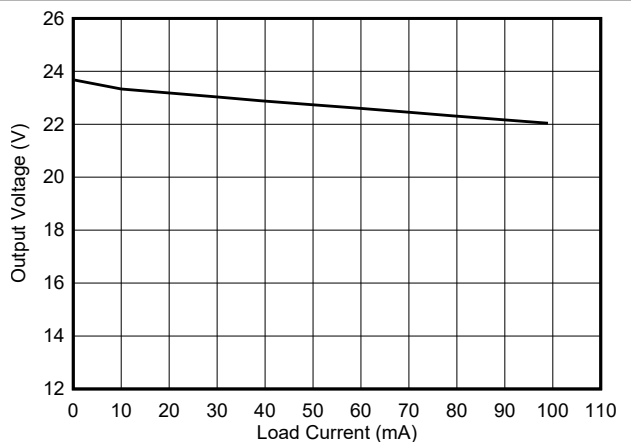

Figure 6-39. Output Voltage vs Load Current

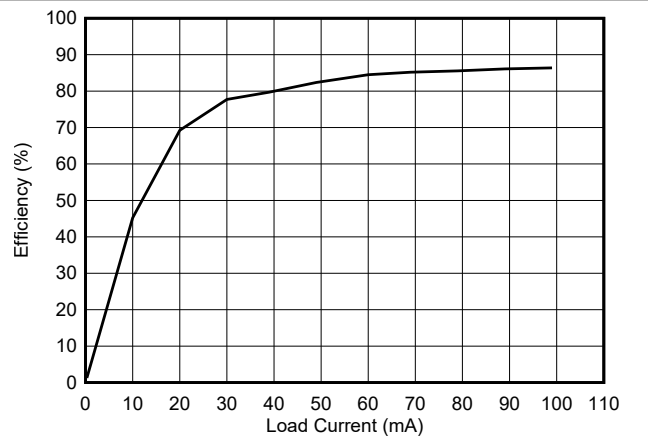

Figure 6-40. Efficiency vs Load Current

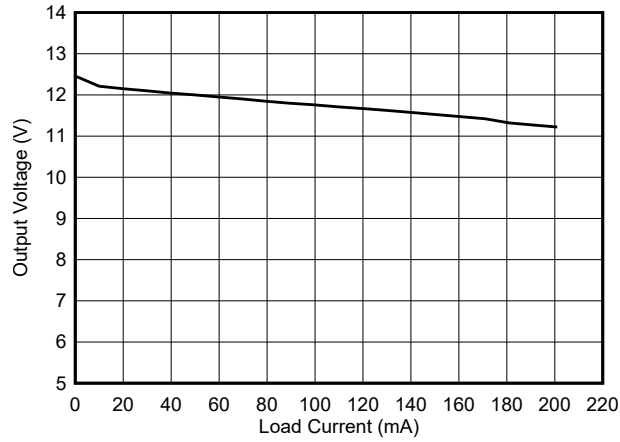

Figure 6-41. Output Voltage vs Load Current

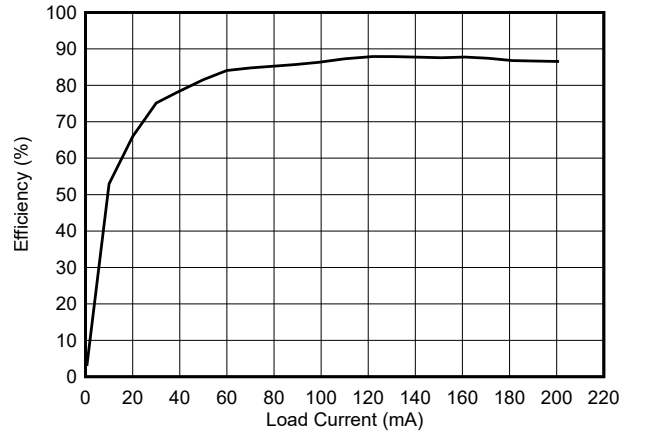

Figure 6-42. Efficiency vs Load Current

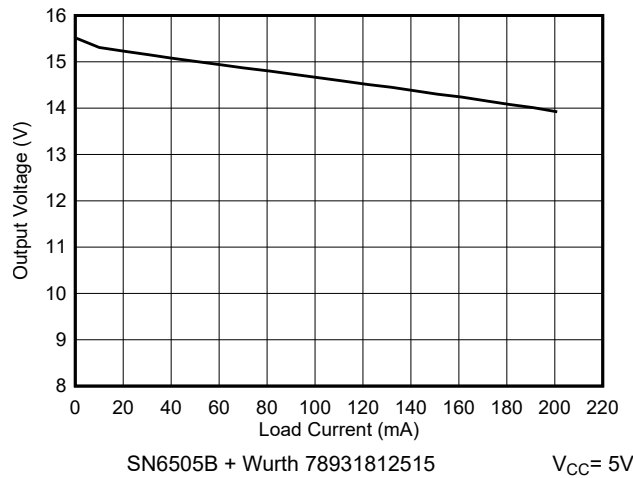

Figure 6-43. Output Voltage vs Load Current

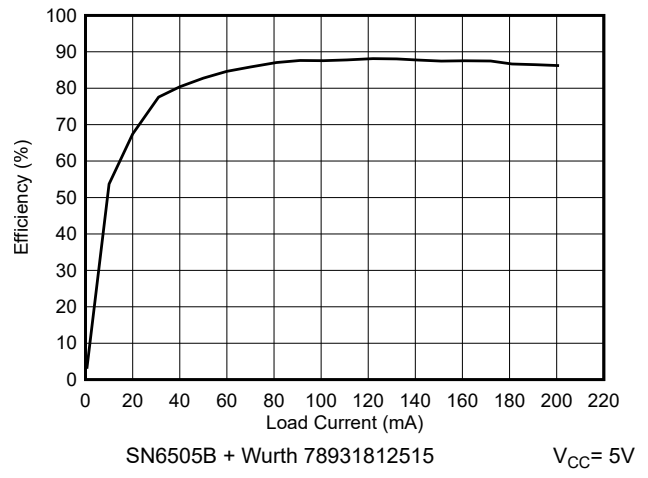

Figure 6-44. Efficiency vs Load Current

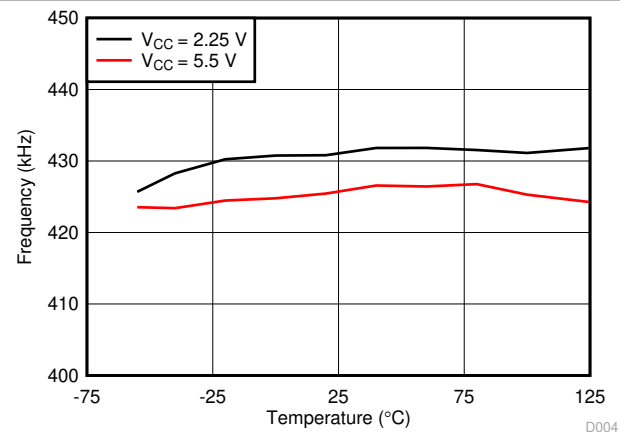

Figure 6-45. Frequency vs Free-Air Temperature

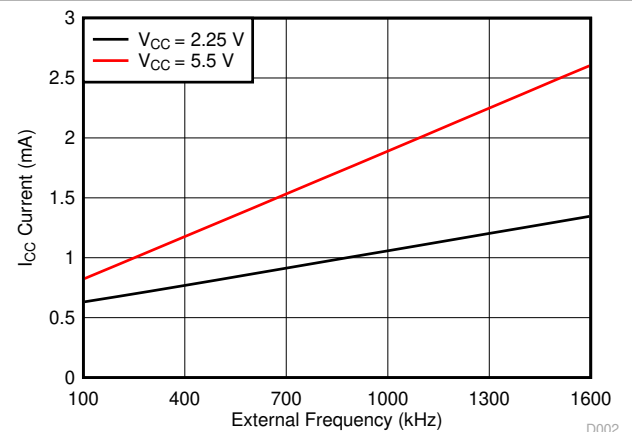

Figure 6-46. Current vs External Frequency

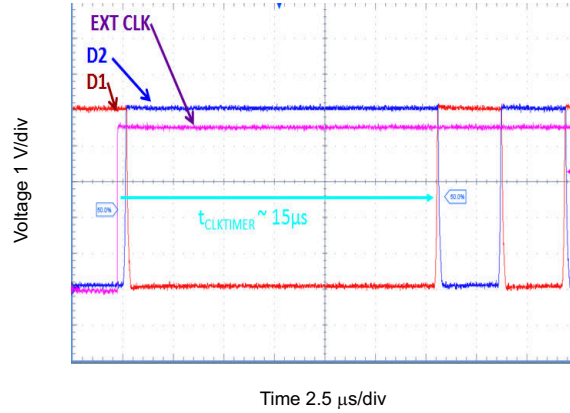

Figure 6-47. Scope Capture of SN6505 Switching from External to Internal Clock

7 Parameter Measurement Information

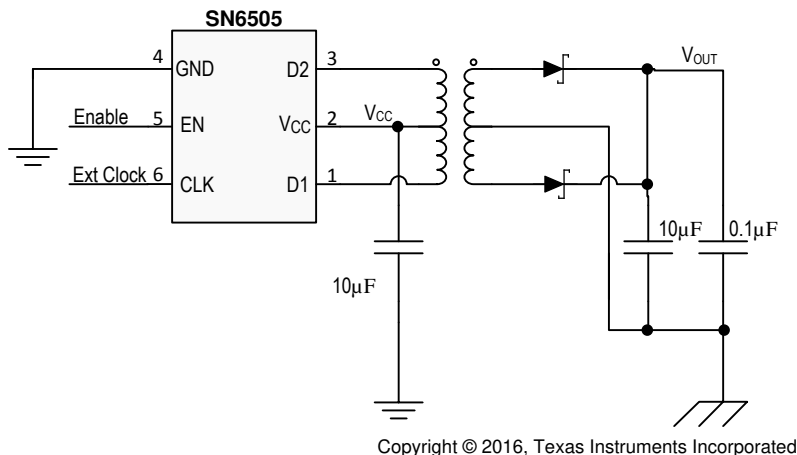

Figure 7-1. Measurement Circuit for Unregulated Output (TP1)

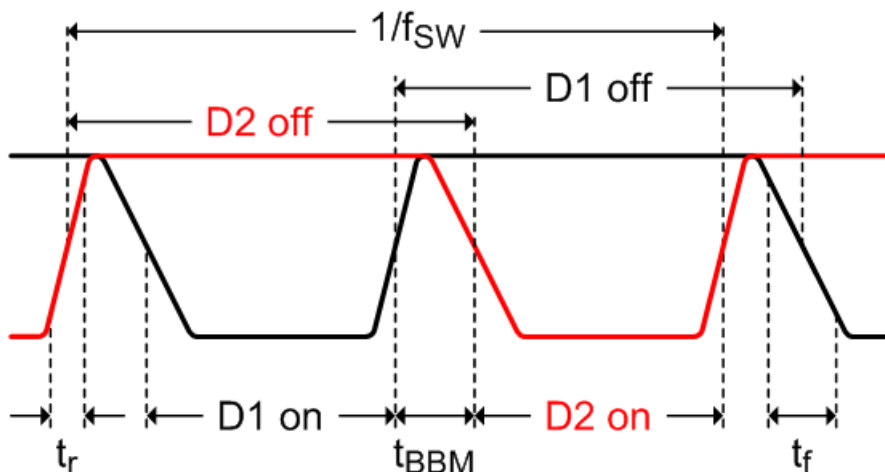

Figure 7-2. Timing Diagram

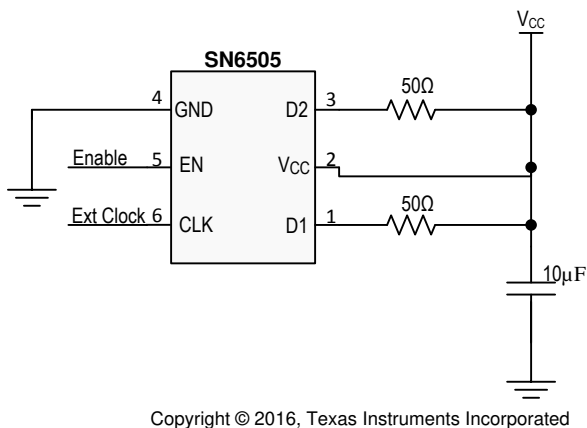
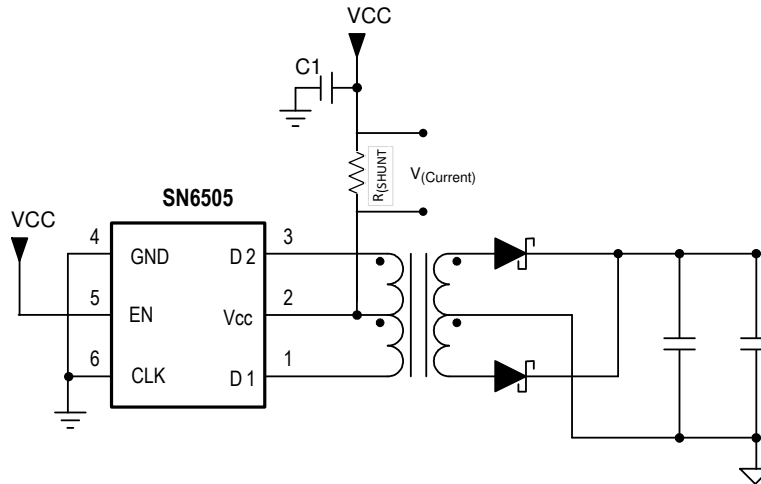

Figure 7-3. Test Circuit for F_{sw} , $V_{(slew)}$, t_{BBM}



Copyright © 2016, Texas Instruments Incorporated

Figure 7-4. $I_{(slew)}$ Test Setup

8 Detailed Description

8.1 Overview

The SN6505 is a transformer driver designed for low-cost, small form-factor, isolated DC/DC converters utilizing the push-pull topology. The device includes an oscillator that feeds a gate-drive circuit. The gate-drive, comprising a frequency divider and a break-before-make (BBM) logic, provides two complementary output signals which alternately turn the two output transistors on and off.

The output frequency of the oscillator is divided down by two. A subsequent break-before-make logic inserts a dead-time between the high-pulses of the two signals. Before either one of the gates can assume logic high, the BBM logic ensures a short time period during which both signals are low and both transistors are high-impedance. This short period, is required to avoid shorting out both ends of the primary. The resulting output signals, present the gate-drive signals for the output transistors.

8.2 Functional Block Diagram

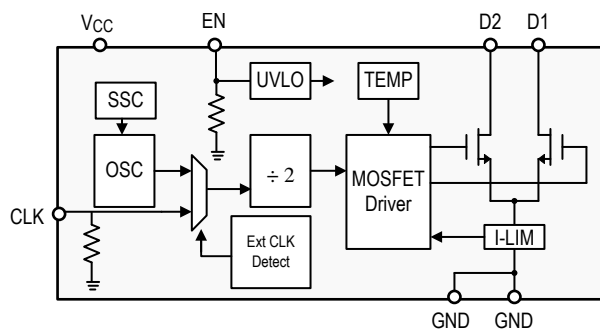

8.3 Feature Description

8.3.1 Push-Pull Converter

Push-pull converters require transformers with center-taps to transfer power from the primary to the secondary (see Figure 8-1).

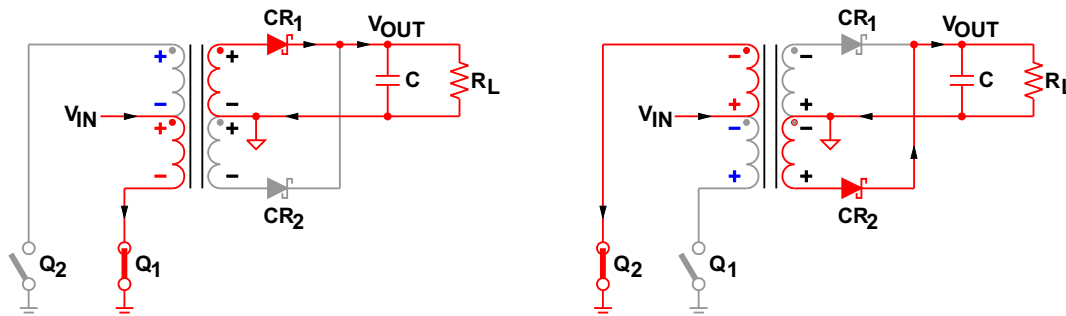

Figure 8-1. Switching Cycles of a Push-Pull Converter

When Q_1 conducts, V_{IN} drives a current through the lower half of the primary to ground, thus creating a negative voltage potential at the lower primary end with regards to the V_{IN} potential at the center-tap.

At the same time the voltage across the upper half of the primary is such that the upper primary end is positive with regards to the center-tap in order to maintain the previously established current flow through Q_2 , which now has turned high-impedance. The two voltage sources, each of which equaling V_{IN} , appear in series and cause a voltage potential at the open end of the primary of $2 \times V_{IN}$ with regards to ground.

Per dot convention the same voltage polarities that occur at the primary also occur at the secondary. The positive potential of the upper secondary end therefore forward biases diode CR_1 . The secondary current starting from the upper secondary end flows through CR_1 , charges capacitor C , and returns through the load impedance R_L back to the center-tap.

When Q_2 conducts, Q_1 goes high-impedance and the voltage polarities at the primary and secondary reverse. Now the lower end of the primary presents the open end with a $2 \times V_{IN}$ potential against ground. In this case CR_2 is forward biased while CR_1 is reverse biased and current flows from the lower secondary end through CR_2 , charging the capacitor and returning through the load to the center-tap.

8.3.2 Core Magnetization

Figure 8-2 shows the ideal magnetizing curve for a push-pull converter with B as the magnetic flux density and H as the magnetic field strength. When Q_1 conducts the magnetic flux is pushed from A to A' , and when Q_2 conducts the flux is pulled back from A' to A . The difference in flux and thus in flux density is proportional to the product of the primary voltage, V_P , and the time, t_{ON} , it is applied to the primary: $B \approx V_P \times t_{ON}$.

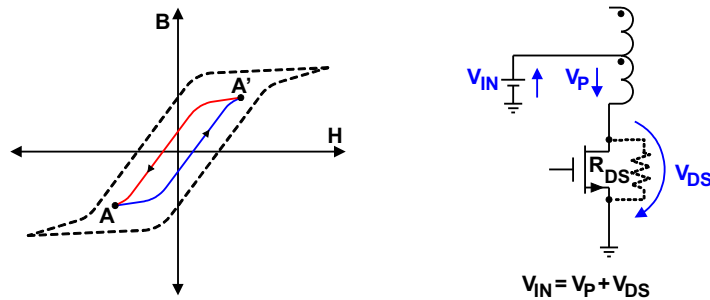

Figure 8-2. Core Magnetization and Self-Regulation Through Positive Temperature Coefficient of $R_{DS(on)}$

This volt-seconds (V-t) product is important as it determines the core magnetization during each switching cycle. If the V-t products of both phases are not identical, an imbalance in flux density swing results with an offset from the origin of the B-H curve. If balance is not restored, the offset increases with each following cycle and the transformer slowly creeps toward the saturation region.

8.4 Device Functional Modes

The functional modes of the device are divided into start-up, operating, and off-mode.

8.4.1 Start-Up Mode

When the supply voltage at V_{CC} ramps up to 2.25 V, the internal oscillator starts operating. The output stage begins switching but the amplitude of the drain signals at D1 and D2 has not reached its full maximum yet.

8.4.1.1 Soft-Start

SN6505A and SN6505B devices support soft-start feature. Upon power up or when EN pin transitions from Low to High, the gate drive of the output power-MOSFET is gradually increased over a period of time from 0 V to V_{CC} . Soft-start prevents high inrush current from V_{CC} while charging large secondary side decoupling capacitors, and also prevents overshoot in secondary voltage during power-up.

8.4.2 Operating Mode

When the device supply has reached its nominal value $\pm 10\%$ the oscillator is fully operating. However variations over supply voltage and operating temperature can vary the switching frequencies at D1 and D2.

8.4.3 Shutdown-Mode

The device has a dedicated enable pin to put the device in very low power mode to save power when not in use. Enable pin has an internal pull down resistor which keeps device disabled when not driven. When disabled or when V_{CC} is < 1.7 V, both drain outputs, D1 and D2, are tri-stated.

8.4.4 Spread Spectrum Clocking

Radiated emissions is an important concern in high current switching power supplies. SN6505 addresses this by modulating its internal clock in such a way that the emitting energy is spread over multiple frequency bins. This Spread Spectrum clocking feature greatly improves the emissions performance of the entire power supply block and hence relieves the system designer from one major concern in isolated power supply design.

8.4.5 External Clock Mode

The SN6505 has a CLK pin which can be used to synchronize the device with system clock and in turn with other SN6505 devices so that the system can control the exact switching frequency of the device. The Rising edge of the CLK is used to divide a clock by two and used to drive the gates. [Figure 9-2](#) shows the timing diagram for the same. The device also has external clock fail safe feature which automatically switches the device to the internal clock if a valid input clock is not present for long ($t_{CLKTIMER}$). The in-built emissions reduction scheme of Spread Spectrum clocking is disabled when external clock is present.

9 Application and Implementation

Note

Information in the following applications sections is not part of the TI component specification, and TI does not warrant its accuracy or completeness. TI's customers are responsible for determining suitability of components for their purposes. Customers should validate and test their design implementation to confirm system functionality.

9.1 Application Information

The SN6505 is a transformer driver designed for low-cost, small form-factor, isolated DC/DC converters using the push-pull topology. The device includes an oscillator that feeds a gate-drive circuit. The gate-drive, comprising a frequency divider and a break-before-make (BBM) logic, provides two complementary output signals which alternately turn the two output transistors on and off.

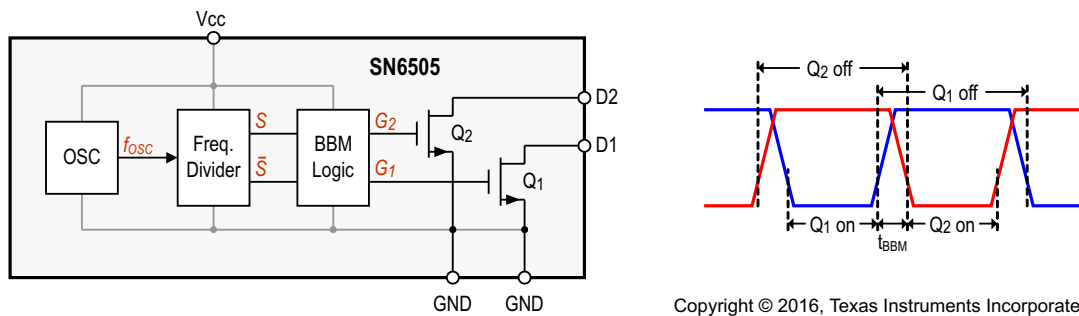

Copyright © 2016, Texas Instruments Incorporated

Figure 9-1. Block Diagram and Output Timing With Break-Before-Make Action

The output frequency of the oscillator is divided down by an asynchronous divider that provides two complementary output signals, S and \bar{S} , with a 50% duty cycle. A subsequent break-before-make logic inserts a dead-time between the high-pulses of the two signals. The resulting output signals, G_1 and G_2 , present the gate-drive signals for the output transistors Q_1 and Q_2 . As shown in [Figure 9-2](#), before either one of the gates can assume logic high, there must be a short time period during which both signals are low and both transistors are high-impedance. This short period, known as break-before-make time, is required to avoid shorting out both ends of the primary.

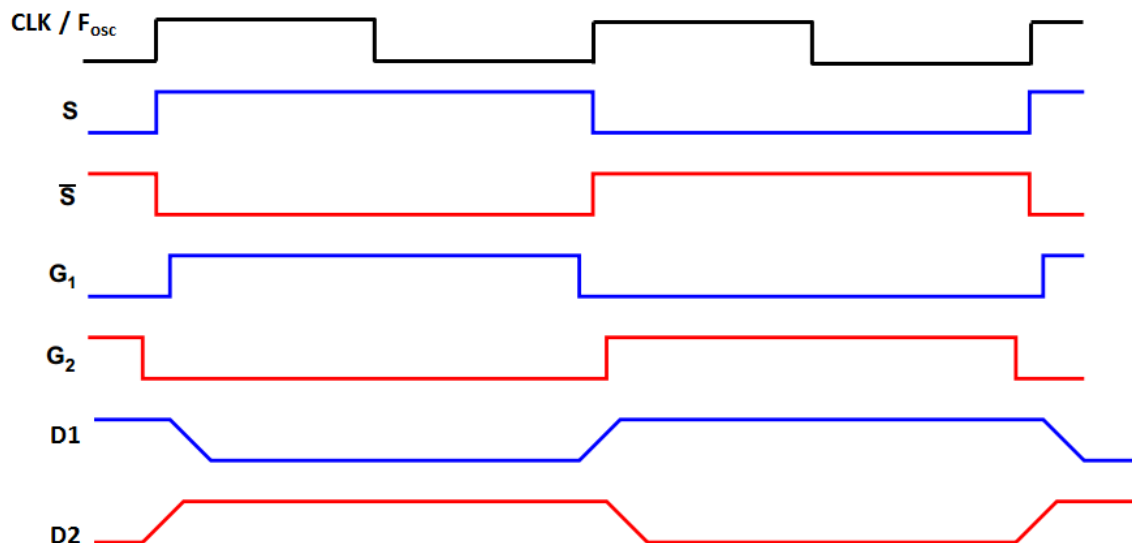

Figure 9-2. Detailed Output Signal Waveforms

9.2 Typical Application

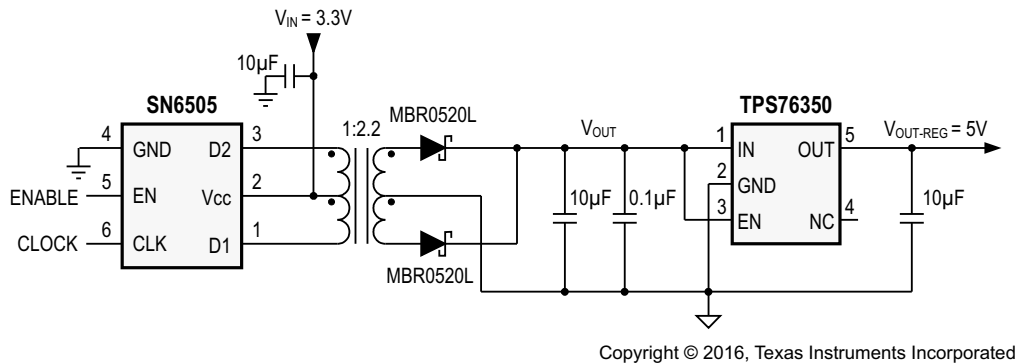

Figure 9-3. Typical Application Schematic

9.2.1 Design Requirements

For this design example, use the parameters listed in [Table 9-1](#) as design parameters.

Table 9-1. Design Parameters

| DESIGN PARAMETER | EXAMPLE VALUE |
|----------------------|---------------|
| Input voltage range | 3.3 V ± 3% |
| Output voltage | 5 V |
| Maximum load current | 100 mA |

9.2.2 Detailed Design Procedure

The following recommendations on components selection focus on the design of an efficient push-pull converter with high current drive capability. Contrary to popular belief, the output voltage of the unregulated converter output drops significantly over a wide range in load current. The characteristic curve in [Figure 6-1](#) and [Figure 6-11](#) for example, shows that the difference between V_{OUT} at minimum load and V_{OUT} at maximum load exceeds a transceiver's supply range. Therefore, in order to provide a stable, load independent supply while maintaining maximum possible efficiency the implementation of a low dropout regulator (LDO) is strongly advised.

The final converter circuit is shown in [Figure 9-8](#). The measured V_{OUT} and efficiency characteristics for the regulated and unregulated outputs are shown in [Figure 6-2](#) and [Figure 6-12](#).

9.2.2.1 Drive Capability

The transformer driver is designed for low-power push-pull converters with input and output voltages in the range of 2.25 V to 5.5 V. While converter designs with higher output voltages are possible, care must be taken that higher turns ratios don't lead to primary currents that exceed the specified current limits of the device.

9.2.2.2 LDO Selection

The minimum requirements for a suitable low dropout regulator are:

- Its current drive capability should slightly exceed the specified load current of the application to prevent the LDO from dropping out of regulation. Therefore, for a load current of 600 mA, choose a 600 mA to 750 mA LDO. While regulators with higher drive capabilities are acceptable, they also usually possess higher dropout voltages that will reduce overall converter efficiency.
- The internal dropout voltage, V_{DO} , at the specified load current should be as low as possible to maintain efficiency. For a low-cost 750 mA LDO, a V_{DO} of 600 mV at 750 mA is common. Be aware; however, that this lower value is usually specified at room temperature and can increase by a factor of 2 over temperature, which in turn will raise the required minimum input voltage.
- The required minimum input voltage preventing the regulator from dropping out of line regulation is given with:

$$V_{I-\min} = V_{DO-\max} + V_{O-\max} \quad (1)$$

This means in order to determine V_I for worst-case condition, the user must take the maximum values for V_{DO} and V_O specified in the LDO data sheet for rated output current (that is, 600 mA) and add them together. Also specify that the output voltage of the push-pull rectifier at the specified load current is equal or higher than $V_{I-\min}$. If it is not, the LDO will lose line-regulation and any variations at the input passes straight through to the output. Hence, below $V_{I-\min}$ the output voltage follows the input and the regulator behaves like a simple conductor.

- The maximum regulator input voltage must be higher than the rectifier output under no-load. Under this condition there is no secondary current reflected back to the primary, thus making the voltage drop across R_{DS-on} negligible and allowing the entire converter input voltage to drop across the primary. At this point, the secondary reaches its maximum voltage of

$$V_{S-\max} = V_{IN-\max} \times n \quad (2)$$

with $V_{IN-\max}$ as the maximum converter input voltage and n as the transformer turns ratio. Thus to prevent the LDO from damage the maximum regulator input voltage must be higher than $V_{S-\max}$. Table 9-2 lists the maximum secondary voltages for various turns ratios commonly applied in push-pull converters.

Table 9-2. Required Maximum LDO Input Voltages for Various Push-Pull Configurations

| PUSH-PULL CONVERTER | | | | LDO |
|-------------------------------|-------------------|------------|------------------|------------------|
| CONFIGURATION | $V_{IN-\max}$ [V] | URNS-RATIO | $V_{S-\max}$ [V] | $V_{I-\max}$ [V] |
| 3.3 V_{IN} to 3.3 V_{OUT} | 3.6 | 1.5 ± 3% | 5.6 | 6 to 10 |
| 3.3 V_{IN} to 5 V_{OUT} | 3.6 | 2.2 ± 3% | 8.2 | 10 |
| 5 V_{IN} to 5 V_{OUT} | 5.5 | 1.5 ± 3% | 8.5 | 10 |

9.2.2.3 Diode Selection

A rectifier diode should always possess low-forward voltage to provide as much voltage to the converter output as possible. When used in high-frequency switching applications, such as the SN6505 however, the diode must also possess a short recovery time. Schottky diodes meet both requirements and are therefore strongly recommended in push-pull converter designs. A good choice for low-volt applications and ambient temperatures of up to 85°C is the low-cost Schottky rectifier MBR0520L with a typical forward voltage of 275 mV at 100-mA forward current. For higher output voltages such as ±10 V and above use the MBR0530 which provides a higher DC blocking voltage of 30 V.

Lab measurements have shown that at temperatures higher than 100°C the leakage currents of the above Schottky diodes increase significantly. This can cause thermal runaway leading to the collapse of the rectifier output voltage. Therefore, for ambient temperatures higher than 85°C use low-leakage Schottky diodes, such as RB168MM-40.

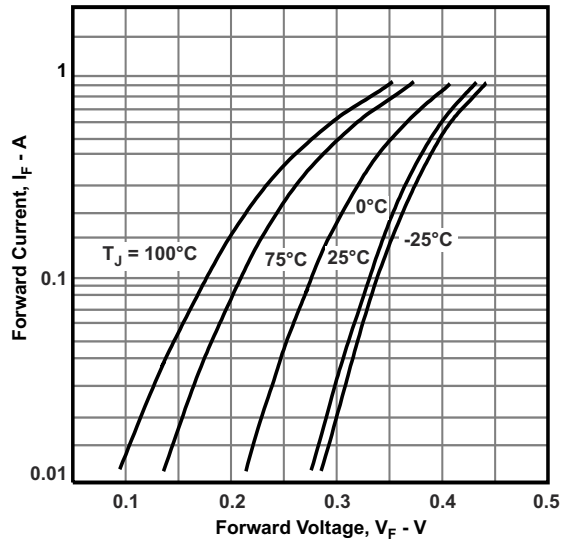

Figure 9-4. Diode Forward Characteristics for MBR0520L

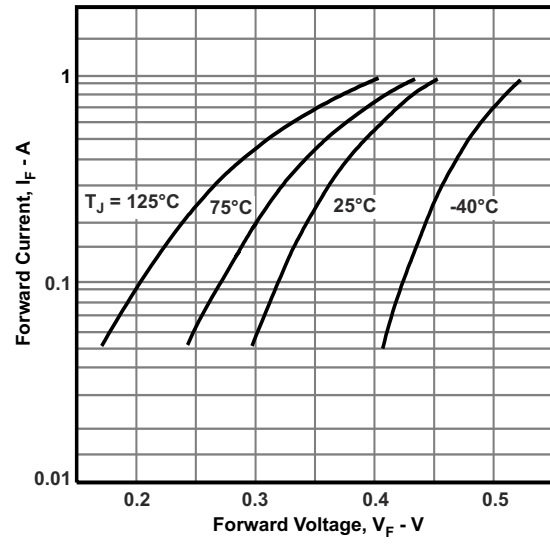

Figure 9-5. Diode Forward Characteristics MBR0530

9.2.2.4 Capacitor Selection

The capacitors in the converter circuit in [Figure 9-8](#) are multi-layer ceramic chip (MLCC) capacitors.

As with all high speed CMOS ICs, the device requires a bypass capacitor in the range of 10 nF to 100 nF.

The input bulk capacitor at the center-tap of the primary supports large currents into the primary during the fast switching transients. For minimum ripple make this capacitor 1 μ F to 10 μ F. In a 2-layer PCB design with a dedicated ground plane, place this capacitor close to the primary center-tap to minimize trace inductance. In a 4-layer board design with low-inductance reference planes for ground and V_{IN} , the capacitor can be placed at the supply entrance of the board. To ensure low-inductance paths use two vias in parallel for each connection to a reference plane or to the primary center-tap.

The bulk capacitor at the rectifier output smooths the output voltage. Make this capacitor 1 μ F to 10 μ F.

The small capacitor at the regulator input is not necessarily required. However, good analog design practice suggests, using a small value of 47 nF to 100 nF improves the regulator's transient response and noise rejection.

The LDO output capacitor buffers the regulated output for the subsequent isolator and transceiver circuitry. The choice of output capacitor depends on the LDO stability requirements specified in the data sheet. However, in most cases, a low-ESR ceramic capacitor in the range of 4.7 μ F to 10 μ F will satisfy these requirements.

9.2.2.5 Transformer Selection

9.2.2.5.1 V-t Product Calculation

To prevent a transformer from saturation its V-t product must be greater than the maximum V-t product applied by the device. The maximum voltage delivered by the device is the nominal converter input plus 10%. The maximum time this voltage is applied to the primary is half the period of the lowest frequency at the specified input voltage. Therefore, the transformer's minimum V-t product is determined through:

$$V_{t_{\min}} \geq V_{IN-\max} \times \frac{T_{\max}}{2} = \frac{V_{IN-\max}}{2 \times f_{\min}} \quad (3)$$

Taking an example of f_{\min} as 138 kHz for [SN6505A](#) and 363 kHz for [SN6505B](#) with a 5 V supply, [Equation 3](#) yields the minimum V-t products of:

$$V_{t_{\min}} \geq \frac{5.5 \text{ V}}{2 \times 138 \text{ kHz}} = 20 \text{ V}\mu\text{s} \quad \text{for SN6505A, and}$$

$$V_{t_{\min}} \geq \frac{5.5 \text{ V}}{2 \times 363 \text{ kHz}} = 7.6 \text{ V}\mu\text{s} \quad \text{for SN6505B applications.} \quad (4)$$

Common V-t values for low-power center-tapped transformers range from 22 $V\mu$ s to 150 $V\mu$ s with typical footprints of 10 mm x 12 mm. However, transformers specifically designed for PCMCIA applications provide as little as 11 $V\mu$ s and come with a significantly reduced footprint of 6 mm x 6 mm only.

While Vt-wise all of these transformers can be driven by the device, other important factors such as isolation voltage, transformer wattage, and turns ratio must be considered before making the final decision.

9.2.2.5.2 Turns Ratio Estimate

Assume the rectifier diodes and linear regulator has been selected. Also, it has been determined that the transformer chosen must have a V-t product of at least 11 $V\mu$ s. However, before searching the manufacturer web sites for a suitable transformer, the user still needs to know its minimum turns ratio that allows the push-pull converter to operate flawlessly over the specified current and temperature range. This minimum transformation ratio is expressed through the ratio of minimum secondary to minimum primary voltage multiplied by a correction factor that takes the transformer's typical efficiency of 97% into account:

$$V_{P-\min} = V_{IN-\min} - V_{DS-\max} \quad (5)$$

$V_{S-\min}$ must be large enough to allow for a maximum voltage drop, $V_{F-\max}$, across the rectifier diode and still provide sufficient input voltage for the regulator to remain in regulation. From the [Section 9.2.2.2](#) section, this minimum input voltage is known and by adding $V_{F-\max}$ gives the minimum secondary voltage with:

$$V_{S-\min} = V_{F-\max} + V_{DO-\max} + V_{O-\max} \quad (6)$$

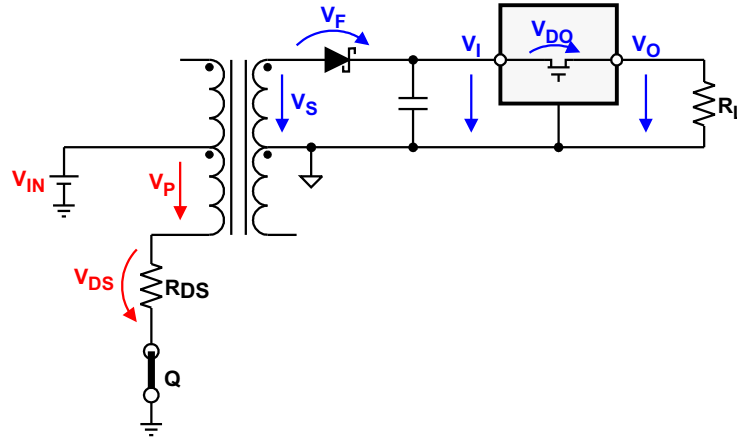

Figure 9-6. Establishing the Required Minimum Turns Ratio Through $N_{\min} = 1.031 \times V_{S-\min} / V_{P-\min}$

Then calculating the available minimum primary voltage, $V_{P-\min}$, involves subtracting the maximum possible drain-source voltage of the device, $V_{DS-\max}$, from the minimum converter input voltage $V_{IN-\min}$:

$$V_{P-\min} = V_{IN-\min} - V_{DS-\max} \quad (7)$$

$V_{DS-\max}$ however, is the product of the maximum $R_{DS(on)}$ and I_D values for a given supply specified in the data sheet:

$$V_{DS-\max} = R_{DS-\max} \times I_{D-\max} \quad (8)$$

Then inserting [Equation 8](#) into [Equation 7](#) yields:

$$V_{P-\min} = V_{IN-\min} - R_{DS-\max} \times I_{D-\max} \quad (9)$$

and inserting [Equation 9](#) and [Equation 6](#) into [Equation 5](#) provides the minimum turns ration with:

$$n_{\min} = 1.031 \times \frac{V_{F-\max} + V_{DO-\max} + V_{O-\max}}{V_{IN-\min} - R_{DS-\max} \times I_{D-\max}} \quad (10)$$

Example:

For a 3.3 V_{IN} to 5 V_{OUT} converter using the rectifier diode MBR0520L and the 5 V LDO, the data sheet values taken for a load current of 600 mA and a maximum temperature of 85°C are $V_{F-\max} = 0.2$ V, $V_{DO-\max} = 0.5$ V, and $V_{O-\max} = 5.1$ V.

Then assuming that the converter input voltage is taken from a 3.3 V controller supply with a maximum $\pm 2\%$ accuracy makes $V_{IN-\min} = 3.234$ V. Finally the maximum values for drain-source resistance and drain current at 3.3 V are taken from the data sheet with $R_{DS-\max} = 0.31$ Ω and $I_{D-\max} = 1$ A.

Inserting the values above into [Equation 10](#) yields a minimum turns ratio of:

$$n_{\min} = 1.031 \times \frac{0.2 \text{ V} + 0.5 \text{ V} + 5.1 \text{ V}}{3.234 \text{ V} - 0.31 \text{ } \Omega \times 1 \text{ A}} = 2.05 \quad (11)$$

Most commercially available transformers for 3-to-5 V push-pull converters offer turns ratios between 2.0 and 2.3 with a common tolerance of $\pm 3\%$.

SN6505A, SN6505B

SLLSEP9I – SEPTEMBER 2015 – REVISED AUGUST 2023

9.2.2.5.3 Recommended Transformers

Depending on the application, use the minimum configuration in Figure 9-7 or standard configuration in Figure 9-8.

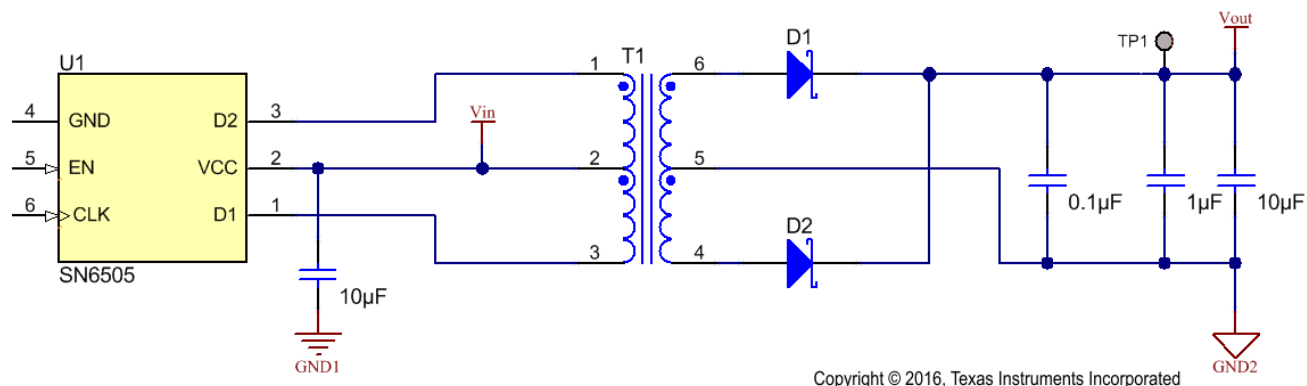

Figure 9-7. Unregulated Output for Low-Current Loads With Wide Supply Range

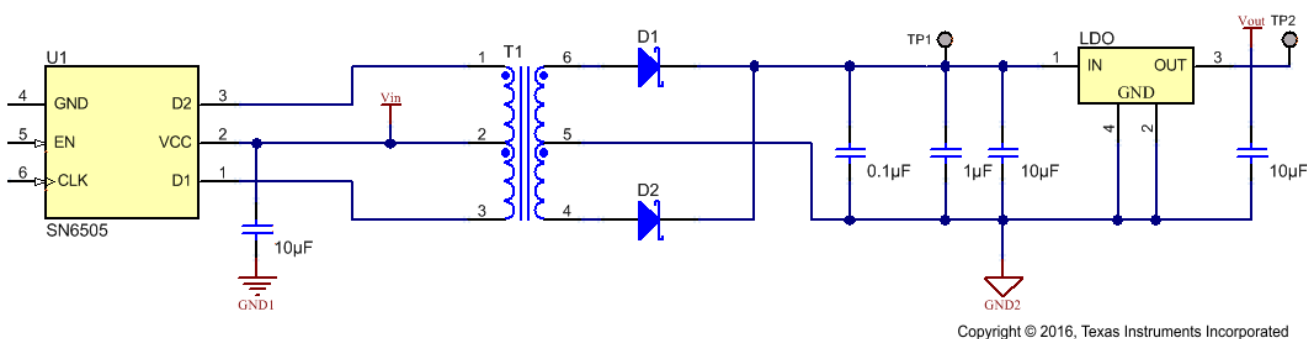

Figure 9-8. Regulated Output for Stable Supplies and High Current Loads

The Würth Electronics Midcom isolation transformers in Table 9-3 are optimized designs for the device, providing high efficiency and small form factor at low-cost.

The 1:1.1 and 1:1.7 turns-ratios are designed for logic applications with wide supply rails and low load currents. These applications operate without LDO, thus achieving further cost-reduction.

Table 9-3. Recommended Isolation Transformers Optimized for the Device

| URNS RATIO | V × T (Vμs) | ISOLATION (V _{RMS}) | DIMENSIONS (mm) | APPLICATION | LDO ⁽¹⁾ | ORDER NO. | MANUFACTURER |
|------------|--|--|--|---|--|----------------|-------------------------------|
| 1:1.1 ±2% | 7 | 2500 | 6.73 x 10.05 x 4.19 | 3.3 V → 3.3 V, 100mA, SN6505B Refer to Figure 6-13 and Figure 6-14 | No | 760390011 | Wurth Electronics / Midcom |
| 1:1.1 ±2% | 11 | | | 5 V → 5 V, 100mA, SN6505B Refer to Figure 6-15 and Figure 6-16 | | 760390012 | |
| 1:1.7 ±2% | | | | 3.3 V → 5 V, 100mA, SN6505B Refer to Figure 6-17 and Figure 6-18 | | 760390013 | |
| 1:1.3 ±2% | | | | 3.3 V → 3.3 V, 100mA, SN6505B Refer to Figure 6-19 and Figure 6-20 | 760390014 | | |
| 1:1.3 ±2% | | | | 5 V → 5 V, 100mA, SN6505B Refer to Figure 6-21 and Figure 6-22 | 760390014 | | |
| 1:2.1 ±2% | | | | 3.3 V → 5 V, 100mA, SN6505B Refer to Figure 6-23 and Figure 6-24 | 760390015 | | |
| 1.23:1 ±2% | | | | 5 V → 3.3 V, 100mA, SN6505B | 750313710 | | |
| 1:1.7 ±2% | | | 8.9 | 8.3 x 12.6 x 4.1 | 3.3 V → 3.3 V, 1A, SN6505B Refer to Figure 6-25 and Figure 6-26 | 750316028 | |
| 1:2.1 ±2% | 3.3 V → 5 V, 1A, SN6505B Refer to Figure 6-27 and Figure 6-28 | | | | 750316029 | | |
| 1.3:1 ±2% | 5 V → 3.3 V, 1A, SN6505B Refer to Figure 6-29 and Figure 6-30 | | | | 750316030 | | |
| | 3.3 V → 3.3 V, 1A, SN6505B 5 V → 5 V, 1A, SN6505B Refer to Figure 6-11 and Figure 6-12 | | | | 750315371 | | |
| 1:1.1 ±2% | 11 | | 9.14 x 12.7 x 7.37 | 3.3 V → 3.3 V, 100mA, SN6505B | Yes | 750313734 | |
| 1:1.1 ±2% | | | | 5 V → 5 V, 100mA, SN6505B | | 750313734 | |
| 1:1.7 ±2% | | | | 3.3 V → 5 V, 100mA, SN6505B | | 750313769 | |
| 1:1.3 ±2% | | 3.3 V → 3.3 V, 100mA, SN6505B 5 V → 5 V, 100mA, SN6505B | | 750313638 | | | |
| 1:2.1 ±2% | | 3.3 V → 5 V, 100mA, SN6505B | | 750313626 | | | |
| 1.3:1 ±2% | | 5 V → 3.3 V, 100mA, SN6505B | | 750313638 | | | |
| 1:1.75 ±2% | | 41 | | 12.32 x 15.41 x 11.05 | 3.3 V → 3.3 V, 1A, SN6505A Refer to Figure 6-3 and Figure 6-4 | Yes | 750316031 |
| 1:2 ±2% | 3.3 V → 5 V, 1A, SN6505A Refer to Figure 6-5 and Figure 6-6 | | 750316032 | | | | |
| 1.3:1 ±2% | 5.0 V → 3.3 V, 1A, SN6505A Refer to Figure 6-7 and Figure 6-8 | | 750316033 | | | | |
| 1:1.1 ±2% | 23 | 12.32 x 15.41 x 11.89 | 3.3 V → 3.3 V, 1A, SN6505A 5 V → 5 V, 1A, SN6505A Refer to Figure 6-1 and Figure 6-2 | | 750315240 | | |
| 1:3.5 ±2% | 9 | 9.14 x 12.95 x 7.62 | 5 V → 17.5 V, 100mA, SN6505B Refer to Figure 6-31 , and Figure 6-32 | | 750342879 | | |
| 1:3.9 ±2% | | 9.17 x 12.7 x 7.62 | 5V → 19.5 V, 100mA, SN6505B Refer to Figure 6-33 , and Figure 6-34 | | 750343725 | | |
| 1:3.75 ±2% | 9.5 | 8.3 x 12.6 x 4.1 | 5V → 18.75 V, 100mA, SN6505B Refer to Figure 6-35 , and Figure 6-35 | No | 78931812518 | | |
| 1:4.75 ±2% | | | 5V → 23.75V, 100mA, SN6505B Refer to Figure 6-37 , and Figure 6-38 | | 78931812523 | | |
| 1:2.5 ±2% | | | 5V → 12.5V, 200mA, SN6505B Refer to Figure 6-39 , and Figure 6-40 | | 78931812512 | | |
| 1:3.13 ±2% | | | 5V → 15.65V, 200mA, SN6505B Refer to Figure 6-41 , and Figure 6-42 | | 78931812515 | | |
| 1:3.5 ±2% | 16 | 6000 | 9.14 x 12.7 x 7.62 | 5V → 17.5V, 100mA, SN6505B Refer to Figure 6-43 , and Figure 6-44 | 750320340 | | |
| 1:1.3 ±3% | 11 | 5000 | 10.4 x 12.2 x 6.1 | 3.3 V → 3.3 V, 300mA, SN6505B 5 V → 5 V, 300mA, SN6505B | No | HCT-SM-1.3-8-2 | Bourns |
| 1:1.1 ±2% | 9.2 | 2500 | 7.01 x 11 x 4.19 | 3.3 V → 3.3 V, 150mA, SN6505B 5 V → 5 V, 150mA, SN6505B | No | EPC3668G-LF | PCA Electronics |

Table 9-3. Recommended Isolation Transformers Optimized for the Device (continued)

| URNS RATIO | V × T (Vμs) | ISOLATION (V _{RMS}) | DIMENSIONS (mm) | APPLICATION | LDO ⁽¹⁾ | ORDER NO. | MANUFACTURER |
|------------|-------------|-------------------------------|-------------------|--|--------------------|-----------|--------------|
| 1:1.5 ±3% | 34.4 | 2500 | 10 x 12.07 x 5.97 | 3.3 V → 3.3 V, 1A, SN6505A/B 5 V → 5 V, 1A, SN6505A/B | Yes | DA2303-AL | Coilcraft |
| 1:2.2 ±3% | 21.5 | 2500 | 10 x 12.07 x 5.97 | 3.3 V → 5 V, 1A, SN6505A/B | | DA2304-AL | |

(1) For configurations with LDO, a higher voltage than the required output voltage is generated, to allow for LDO drop-out. Figures show the voltage and efficiency at the LDO input.

9.2.3 Application Curves

See the [Section 6.7](#) and [Section 6.8](#) for application curves with transformers optimized for the device, providing high efficiency and small form factor at low-cost.

9.2.4 System Examples

9.2.4.1 Higher Output Voltage Designs

The device can drive push-pull converters that provide high output voltages of up to 30 V, or bipolar outputs of up to ± 15 V. Using commercially available center-tapped transformers, with their rather low turns ratios of 0.8 to 5, requires different rectifier topologies to achieve high output voltages. Figure 9-9 to Figure 9-11 show some of these topologies together with their respective open-circuit output voltages.

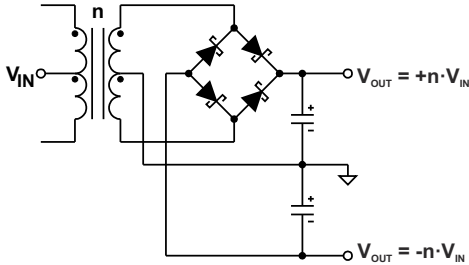

Figure 9-9. Bridge Rectifier With Center-Tapped Secondary Enables Bipolar Outputs

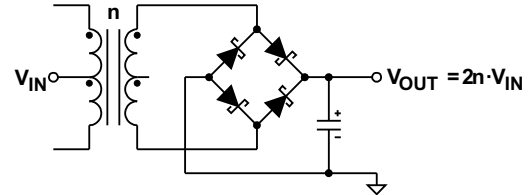

Figure 9-10. Bridge Rectifier Without Center-Tapped Secondary Performs Voltage Doubling

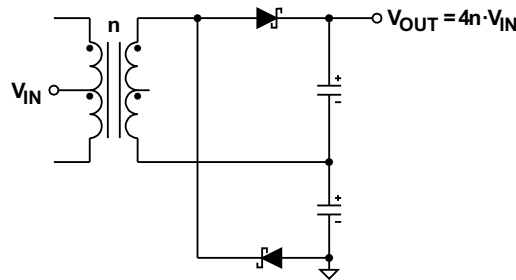

Figure 9-11. Half-Wave Rectifier Without Centered Ground and Center-Tapped Secondary Performs Voltage Doubling Twice, Hence Quadrupling V_{IN}

9.2.4.2 Application Circuits

The following application circuits are shown for a 3.3 V input supply commonly taken from the local, regulated microcontroller supply. For 5 V input voltages requiring different turn ratios refer to the transformer manufacturers and their web sites listed in Table 9-4.

Table 9-4. Transformer Manufacturers

| MANUFACTURER | MORE INFORMATION |
|------------------------------|---|
| Coilcraft Inc. | http://www.coilcraft.com |
| Halo-Electronics Inc. | http://www.haloelectronics.com |
| Murata Power Solutions | http://www.murata-ps.com |
| Würth Electronics Midcom Inc | http://www.midcom-inc.com |

10 Power Supply Recommendations

The device is designed to operate from an input voltage supply range between 2.5 V and 5 V nominal. This input supply must be regulated within $\pm 10\%$. If the input supply is located more than a few inches from the device, a 0.1 μF by-pass capacitor should be connected as close as possible to the device V_{CC} pin and a 10 μF capacitor should be connected close to the transformer center-tap pin.

11 Layout

11.1 Layout Guidelines

- The V_{IN} pin must be buffered to ground with a low-ESR ceramic bypass-capacitor. The recommended capacitor value can range from 1 μF to 10 μF . The capacitor must have a voltage rating of 10 V minimum and a X5R or X7R dielectric.
- The optimum placement is closest to the V_{IN} and GND pins at the board entrance to minimize the loop area formed by the bypass-capacitor connection, the V_{IN} terminal, and the GND pin. See [Figure 11-1](#) for a PCB layout example.
- The connections between the device D1 and D2 pins and the transformer primary endings, and the connection of the device V_{CC} pin and the transformer center-tap must be as close as possible for minimum trace inductance.
- The connection of the device V_{CC} pin and the transformer center-tap must be buffered to ground with a low-ESR ceramic bypass-capacitor. The recommended capacitor value can range from 1 μF to 10 μF . The capacitor must have a voltage rating of 16 V minimum and a X5R or X7R dielectric.
- The device GND pins must be tied to the PCB ground plane using two vias for minimum inductance.
- The ground connections of the capacitors and the ground plane should use two vias for minimum inductance.
- The rectifier diodes should be Schottky diodes with low forward voltage in the 10 mA to 100 mA current range to maximize efficiency.
- The V_{OUT} pin must be buffered to ISO-Ground with a low-ESR ceramic bypass-capacitor. The recommended capacitor value can range from 1 μF to 10 μF . The capacitor must have a voltage rating of 16 V minimum and a X5R or X7R dielectric.

11.2 Layout Example

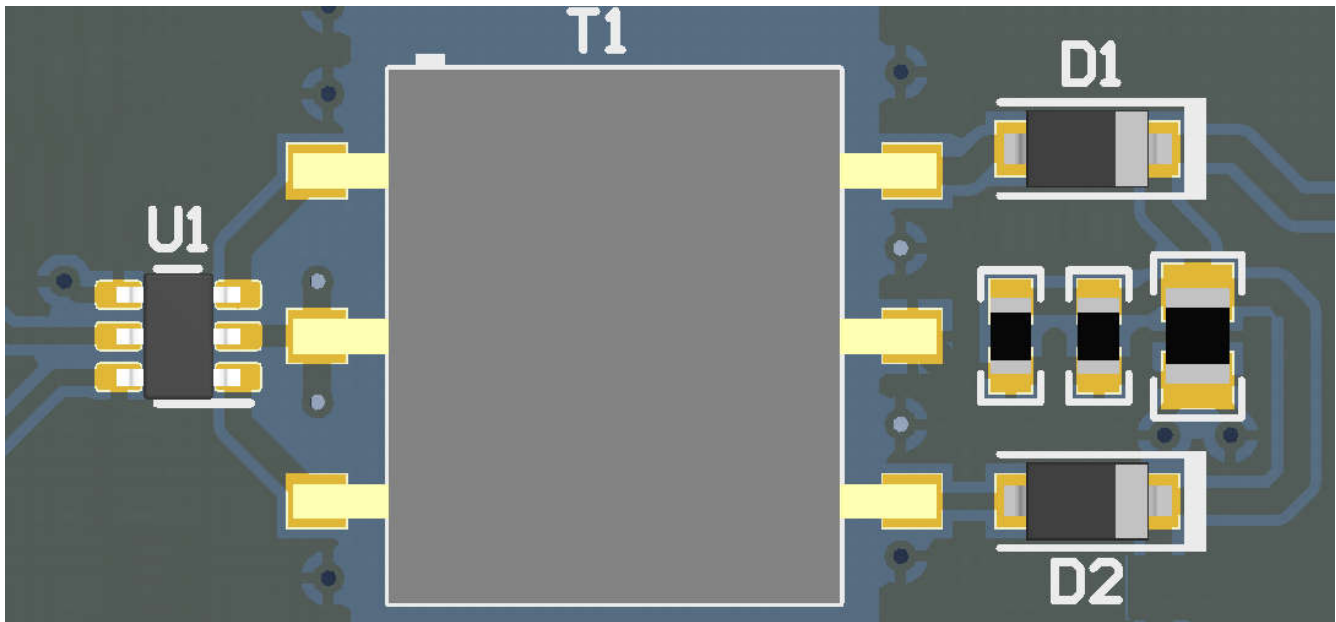

Figure 11-1. Layout Example of a 2-Layer Board

12 Device and Documentation Support

12.1 Device Support

12.2 Documentation Support

12.2.1 Related Documentation

For related documentation see the following:

- Texas Instruments, [Digital Isolator Design Guide](#)
- Texas Instruments, [Isolation Glossary](#)
- Texas Instruments, [How to Isolate Signal and Power in Isolated CAN Systems TI TechNote](#)
- Texas Instruments, [Small Form-Factor Reinforced Isolated IGBT Gate Drive Reference Design for 3-Phase Inverter TI Design](#)

12.3 Related Links

The table below lists quick access links. Categories include technical documents, support and community resources, tools and software, and quick access to order now.

Table 12-1. Related Links

| PARTS | PRODUCT FOLDER | ORDER NOW | TECHNICAL DOCUMENTS | TOOLS & SOFTWARE | SUPPORT & COMMUNITY |
|---------|----------------------------|----------------------------|----------------------------|----------------------------|----------------------------|
| SN6505A | Click here | Click here | Click here | Click here | Click here |
| SN6505B | Click here | Click here | Click here | Click here | Click here |

12.4 Receiving Notification of Documentation Updates

To receive notification of documentation updates, navigate to the device product folder on ti.com. In the upper right corner, click on *Alert me* to register and receive a weekly digest of any product information that has changed. For change details, review the revision history included in any revised document.

12.5 Community Resources

12.6 Trademarks

All trademarks are the property of their respective owners.

13 Mechanical, Packaging, and Orderable Information

The following pages include mechanical, packaging, and orderable information. This information is the most current data available for the designated devices. This data is subject to change without notice and revision of this document. For browser-based versions of this data sheet, refer to the left-hand navigation.

PACKAGING INFORMATION

| Orderable part number | Status (1) | Material type (2) | Package Pins | Package qty Carrier | RoHS (3) | Lead finish/ Ball material (4) | MSL rating/ Peak reflow (5) | Op temp (°C) | Part marking (6) |
|-----------------------------|---------------|----------------------|------------------|-----------------------|-------------|--------------------------------------|-----------------------------------|--------------|---------------------|
| SN6505ADBVR | Active | Production | SOT-23 (DBV) 6 | 3000 LARGE T&R | Yes | NIPDAU | Level-1-260C-UNLIM | -55 to 125 | (650A, 65AQ) |
| SN6505ADBVR.A | Active | Production | SOT-23 (DBV) 6 | 3000 LARGE T&R | Yes | NIPDAU | Level-1-260C-UNLIM | -55 to 125 | (650A, 65AQ) |
| SN6505ADBVT | Active | Production | SOT-23 (DBV) 6 | 250 SMALL T&R | Yes | NIPDAU | Level-1-260C-UNLIM | -55 to 125 | (650A, 65AQ) |
| SN6505ADBVT.A | Active | Production | SOT-23 (DBV) 6 | 250 SMALL T&R | Yes | NIPDAU | Level-1-260C-UNLIM | -55 to 125 | (650A, 65AQ) |
| SN6505BDBVR | Active | Production | SOT-23 (DBV) 6 | 3000 LARGE T&R | Yes | NIPDAU | Level-1-260C-UNLIM | -55 to 125 | (650B, 65BQ) |
| SN6505BDBVR.A | Active | Production | SOT-23 (DBV) 6 | 3000 LARGE T&R | Yes | NIPDAU | Level-1-260C-UNLIM | -55 to 125 | (650B, 65BQ) |
| SN6505BDBVRG4 | Active | Production | SOT-23 (DBV) 6 | 3000 LARGE T&R | Yes | NIPDAU | Level-1-260C-UNLIM | -55 to 125 | 65BQ |
| SN6505BDBVRG4.A | Active | Production | SOT-23 (DBV) 6 | 3000 LARGE T&R | Yes | NIPDAU | Level-1-260C-UNLIM | -55 to 125 | 65BQ |
| SN6505BDBVT | Active | Production | SOT-23 (DBV) 6 | 250 SMALL T&R | Yes | NIPDAU | Level-1-260C-UNLIM | -55 to 125 | (650B, 65BQ) |
| SN6505BDBVT.A | Active | Production | SOT-23 (DBV) 6 | 250 SMALL T&R | Yes | NIPDAU | Level-1-260C-UNLIM | -55 to 125 | (650B, 65BQ) |

(1) **Status:** For more details on status, see our [product life cycle](#).

(2) **Material type:** When designated, preproduction parts are prototypes/experimental devices, and are not yet approved or released for full production. Testing and final process, including without limitation quality assurance, reliability performance testing, and/or process qualification, may not yet be complete, and this item is subject to further changes or possible discontinuation. If available for ordering, purchases will be subject to an additional waiver at checkout, and are intended for early internal evaluation purposes only. These items are sold without warranties of any kind.

(3) **RoHS values:** Yes, No, RoHS Exempt. See the [TI RoHS Statement](#) for additional information and value definition.

(4) **Lead finish/Ball material:** Parts may have multiple material finish options. Finish options are separated by a vertical ruled line. Lead finish/Ball material values may wrap to two lines if the finish value exceeds the maximum column width.

(5) **MSL rating/Peak reflow:** The moisture sensitivity level ratings and peak solder (reflow) temperatures. In the event that a part has multiple moisture sensitivity ratings, only the lowest level per JEDEC standards is shown. Refer to the shipping label for the actual reflow temperature that will be used to mount the part to the printed circuit board.

(6) **Part marking:** There may be an additional marking, which relates to the logo, the lot trace code information, or the environmental category of the part.

Multiple part markings will be inside parentheses. Only one part marking contained in parentheses and separated by a "~" will appear on a part. If a line is indented then it is a continuation of the previous line and the two combined represent the entire part marking for that device.

Important Information and Disclaimer: The information provided on this page represents TI's knowledge and belief as of the date that it is provided. TI bases its knowledge and belief on information provided by third parties, and makes no representation or warranty as to the accuracy of such information. Efforts are underway to better integrate information from third parties. TI has taken and continues to take reasonable steps to provide representative

and accurate information but may not have conducted destructive testing or chemical analysis on incoming materials and chemicals. TI and TI suppliers consider certain information to be proprietary, and thus CAS numbers and other limited information may not be available for release.

In no event shall TI's liability arising out of such information exceed the total purchase price of the TI part(s) at issue in this document sold by TI to Customer on an annual basis.

OTHER QUALIFIED VERSIONS OF SN6505A, SN6505B :

- Automotive : [SN6505A-Q1](#), [SN6505B-Q1](#)

NOTE: Qualified Version Definitions:

- Automotive - Q100 devices qualified for high-reliability automotive applications targeting zero defects

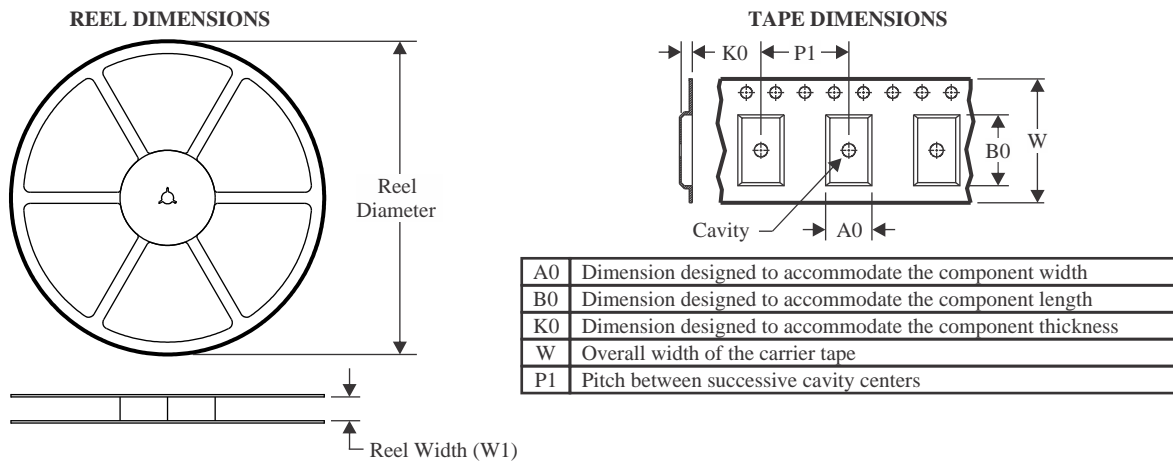
TAPE AND REEL INFORMATION

QUADRANT ASSIGNMENTS FOR PIN 1 ORIENTATION IN TAPE

*All dimensions are nominal

| Device | Package Type | Package Drawing | Pins | SPQ | Reel Diameter (mm) | Reel Width W1 (mm) | A0 (mm) | B0 (mm) | K0 (mm) | P1 (mm) | W (mm) | Pin1 Quadrant |
|---------------|--------------|-----------------|------|------|--------------------|--------------------|---------|---------|---------|---------|--------|---------------|
| SN6505ADBVR | SOT-23 | DBV | 6 | 3000 | 180.0 | 8.4 | 3.2 | 3.2 | 1.4 | 4.0 | 8.0 | Q3 |
| SN6505ADBVR | SOT-23 | DBV | 6 | 3000 | 178.0 | 9.0 | 3.23 | 3.17 | 1.37 | 4.0 | 8.0 | Q3 |
| SN6505ADBVT | SOT-23 | DBV | 6 | 250 | 180.0 | 8.4 | 3.2 | 3.2 | 1.4 | 4.0 | 8.0 | Q3 |
| SN6505BDBVR | SOT-23 | DBV | 6 | 3000 | 180.0 | 8.4 | 3.2 | 3.2 | 1.4 | 4.0 | 8.0 | Q3 |
| SN6505BDBVRG4 | SOT-23 | DBV | 6 | 3000 | 180.0 | 8.4 | 3.2 | 3.2 | 1.4 | 4.0 | 8.0 | Q3 |
| SN6505BDBVT | SOT-23 | DBV | 6 | 250 | 178.0 | 9.0 | 3.23 | 3.17 | 1.37 | 4.0 | 8.0 | Q3 |
| SN6505BDBVT | SOT-23 | DBV | 6 | 250 | 180.0 | 8.4 | 3.2 | 3.2 | 1.4 | 4.0 | 8.0 | Q3 |

TAPE AND REEL BOX DIMENSIONS

*All dimensions are nominal

| Device | Package Type | Package Drawing | Pins | SPQ | Length (mm) | Width (mm) | Height (mm) |
|---------------|--------------|-----------------|------|------|-------------|------------|-------------|
| SN6505ADBVR | SOT-23 | DBV | 6 | 3000 | 210.0 | 185.0 | 35.0 |
| SN6505ADBVR | SOT-23 | DBV | 6 | 3000 | 180.0 | 180.0 | 18.0 |
| SN6505ADBVT | SOT-23 | DBV | 6 | 250 | 210.0 | 185.0 | 35.0 |
| SN6505BDBVR | SOT-23 | DBV | 6 | 3000 | 210.0 | 185.0 | 35.0 |
| SN6505BDBVRG4 | SOT-23 | DBV | 6 | 3000 | 210.0 | 185.0 | 35.0 |
| SN6505BDBVT | SOT-23 | DBV | 6 | 250 | 180.0 | 180.0 | 18.0 |
| SN6505BDBVT | SOT-23 | DBV | 6 | 250 | 210.0 | 185.0 | 35.0 |

DBV0006A



PACKAGE OUTLINE

SOT-23 - 1.45 mm max height

SMALL OUTLINE TRANSISTOR

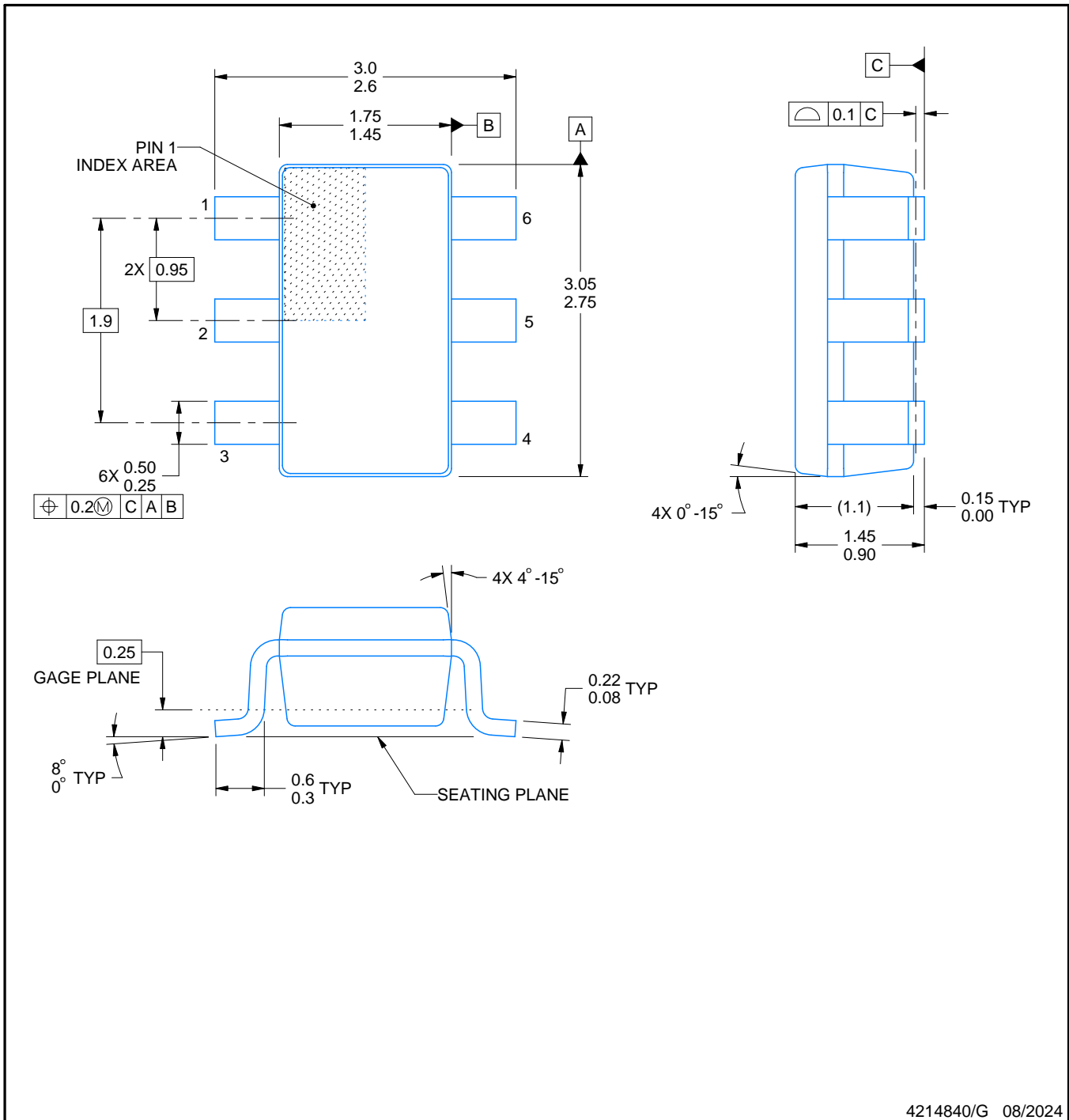

4214840/G 08/2024

NOTES:

1. All linear dimensions are in millimeters. Any dimensions in parenthesis are for reference only. Dimensioning and tolerancing per ASME Y14.5M.
2. This drawing is subject to change without notice.
3. Body dimensions do not include mold flash or protrusion. Mold flash and protrusion shall not exceed 0.25 per side.
4. Leads 1,2,3 may be wider than leads 4,5,6 for package orientation.
5. Reference JEDEC MO-178.

EXAMPLE BOARD LAYOUT

DBV0006A

SOT-23 - 1.45 mm max height

SMALL OUTLINE TRANSISTOR



LAND PATTERN EXAMPLE
EXPOSED METAL SHOWN
SCALE:15X

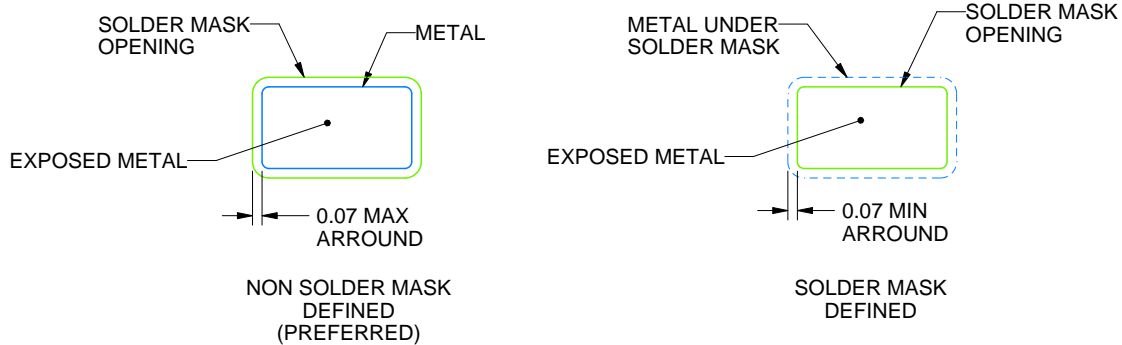

SOLDER MASK DETAILS

4214840/G 08/2024

NOTES: (continued)

6. Publication IPC-7351 may have alternate designs.
7. Solder mask tolerances between and around signal pads can vary based on board fabrication site.

EXAMPLE STENCIL DESIGN

DBV0006A

SOT-23 - 1.45 mm max height

SMALL OUTLINE TRANSISTOR



SOLDER PASTE EXAMPLE
BASED ON 0.125 mm THICK STENCIL
SCALE:15X

4214840/G 08/2024

NOTES: (continued)

8. Laser cutting apertures with trapezoidal walls and rounded corners may offer better paste release. IPC-7525 may have alternate design recommendations.
9. Board assembly site may have different recommendations for stencil design.

IMPORTANT NOTICE AND DISCLAIMER

TI PROVIDES TECHNICAL AND RELIABILITY DATA (INCLUDING DATASHEETS), DESIGN RESOURCES (INCLUDING REFERENCE DESIGNS), APPLICATION OR OTHER DESIGN ADVICE, WEB TOOLS, SAFETY INFORMATION, AND OTHER RESOURCES "AS IS" AND WITH ALL FAULTS, AND DISCLAIMS ALL WARRANTIES, EXPRESS AND IMPLIED, INCLUDING WITHOUT LIMITATION ANY IMPLIED WARRANTIES OF MERCHANTABILITY, FITNESS FOR A PARTICULAR PURPOSE OR NON-INFRINGEMENT OF THIRD PARTY INTELLECTUAL PROPERTY RIGHTS.

These resources are intended for skilled developers designing with TI products. You are solely responsible for (1) selecting the appropriate TI products for your application, (2) designing, validating and testing your application, and (3) ensuring your application meets applicable standards, and any other safety, security, regulatory or other requirements.

These resources are subject to change without notice. TI grants you permission to use these resources only for development of an application that uses the TI products described in the resource. Other reproduction and display of these resources is prohibited. No license is granted to any other TI intellectual property right or to any third party intellectual property right. TI disclaims responsibility for, and you fully indemnify TI and its representatives against any claims, damages, costs, losses, and liabilities arising out of your use of these resources.

TI's products are provided subject to [TI's Terms of Sale](#), [TI's General Quality Guidelines](#), or other applicable terms available either on ti.com or provided in conjunction with such TI products. TI's provision of these resources does not expand or otherwise alter TI's applicable warranties or warranty disclaimers for TI products. Unless TI explicitly designates a product as custom or customer-specified, TI products are standard, catalog, general purpose devices.

TI objects to and rejects any additional or different terms you may propose.

Copyright © 2026, Texas Instruments Incorporated

Last updated 10/2025