

SN74AVC4T245-Q1 Automotive 4-Bit Dual-Supply Bus Transceiver with Configurable Voltage Translation and 3-State Outputs

1 Features

- Qualified for automotive applications
- AEC-Q100 qualified with the following results:
 - Device temperature grade 1: –40°C to 125°C ambient operating temperature range
 - Device HBM ESD classification level H3B (JESD 22 A114-A)
 - Device CDM ESD classification level C5 (JESD 22 C101)
- [Function safety capable](#)
- Control input V_{IH} and V_{IL} levels are referenced to V_{CCA} voltage
- Fully configurable dual-rail design allows each port to operate over the full 1.2V to 3.6V power-supply range
- I/Os are 4.6V tolerant
- I_{off} supports partial power-down-mode operation
- Maximum data rates:
 - 380Mbps (1.8V to 3.3V translation)
 - 200Mbps (<1.8V to 3.3V translation)
 - 200Mbps (translate to 2.5V or 1.8V)
 - 150Mbps (translate to 1.5V)
 - 100Mbps (translate to 1.2V)
- Latch-up performance exceeds 100mA per JESD 78, Class II

2 Applications

- [Telematics](#)
- [Cluster](#)
- [Head unit](#)
- [Navigation systems](#)

3 Description

This 4-bit non-inverting bus transceiver uses two separate configurable power-supply rails. The A port is designed to track V_{CCA} . V_{CCA} accepts any supply voltage from 1.2V to 3.6V. The B port is designed to track V_{CCB} . V_{CCB} accepts any supply voltage from 1.2V to 3.6V. The SN74AVC4T245-Q1 is optimized to operate with V_{CCA}/V_{CCB} set at 1.4V to 3.6V. It is operational with V_{CCA}/V_{CCB} as low as 1.2V. This allows for universal low-voltage bidirectional translation between any of the 1.2V, 1.5V, 1.8V, 2.5V, and 3.3V voltage nodes.

The SN74AVC4T245-Q1 is designed for asynchronous communication between two data buses. The logic levels of the direction-control (DIR) input and the output-enable (\overline{OE}) input activate either the B-port outputs or the A-port outputs or place both output ports into the high-impedance mode. The device transmits data from the A bus to the B bus when the B-port outputs are activated, and from the B bus to the A bus when the A-port outputs are activated. The input circuitry on both A and B ports is always active and must have a logic HIGH or LOW level applied to prevent excess I_{CC} and I_{CCZ} .

The SN74AVC4T245-Q1 is designed so that the control pins (1DIR, 2DIR, 1 \overline{OE} , and 2 \overline{OE}) are supplied by V_{CCA} .

This device is fully specified for partial-power-down applications using I_{off} . The I_{off} circuitry disables the outputs, preventing damaging current backflow through the device when it is powered down.

The design of the V_{CC} isolation feature places both ports in the high-impedance state if either V_{CC} input is at GND.

To place the device in the high-impedance state during power up or power down, tie \overline{OE} to V_{CC} through a pullup resistor; the current-sinking capability of the driver determines the minimum value of the resistor.

Package Information

PART NUMBER	PACKAGE ⁽¹⁾	PACKAGE SIZE ⁽²⁾
SN74AVC4T245-Q1	RGY (VQFN, 16)	4mm × 3.5mm
	PW (TSSOP, 16)	5mm × 6.4mm
	BQB (WQFN, 16)	3.5mm × 2.5mm
	DYY (SOT, 16)	4.2mm × 2mm

(1) For more information, see [Section 11](#)

(2) The package size (length × width) is a nominal value and includes pins, where applicable.



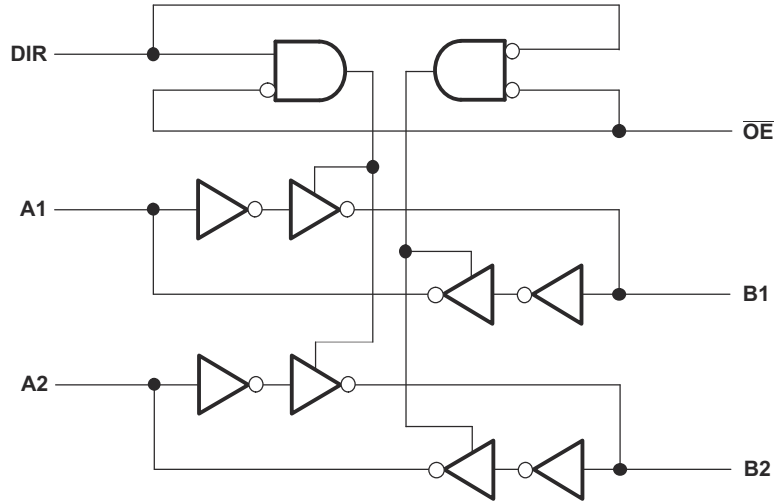

Logic Diagram (Positive Logic) for 1/2 of SN74AVC4T245-Q1

Table of Contents

1 Features	1	7.1 Overview.....	18
2 Applications	1	7.2 Functional Block Diagram.....	18
3 Description	1	7.3 Feature Description.....	19
4 Pin Configuration and Functions	4	7.4 Device Functional Modes.....	19
5 Specifications	6	8 Application and Implementation	20
5.1 Absolute Maximum Ratings.....	6	8.1 Application Information.....	20
5.2 ESD Ratings.....	6	8.2 Typical Application.....	20
5.3 Recommended Operating Conditions	6	8.3 Power Supply Recommendations.....	21
5.4 Thermal Information.....	7	8.4 Layout.....	22
5.5 Electrical Characteristics	8	9 Device and Documentation Support	23
5.6 Switching Characteristics: $V_{CCA} = 1.2V$	9	9.1 Documentation Support.....	23
5.7 Switching Characteristics: $V_{CCA} = 1.5V \pm 0.1V$	10	9.2 Receiving Notification of Documentation Updates....	23
5.8 Switching Characteristics: $V_{CCA} = 1.8V \pm 0.15V$	11	9.3 Support Resources.....	23
5.9 Switching Characteristics: $V_{CCA} = 2.5V \pm 0.2V$	11	9.4 Trademarks.....	23
5.10 Switching Characteristics: $V_{CCA} = 3.3V \pm 0.3V$	12	9.5 Electrostatic Discharge Caution.....	23
5.11 Operating Characteristics.....	14	9.6 Glossary.....	23
5.12 Typical Characteristics.....	15	10 Revision History	23
6 Parameter Measurement Information	17	11 Mechanical, Packaging, and Orderable Information	23
7 Detailed Description	18		

4 Pin Configuration and Functions

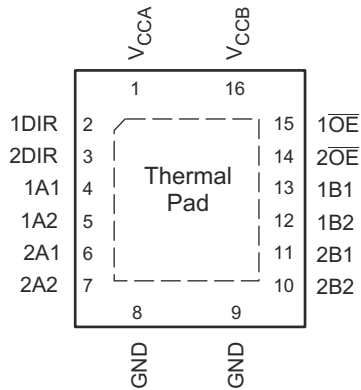

Figure 4-1. RGY Package 16-Pin VQFN With Exposed Thermal Pad (Top View)

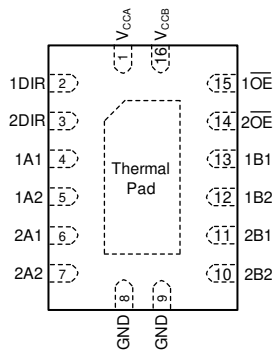

Figure 4-3. BQB/WBQB Package 16-Pin WQFN (Transparent Top View)

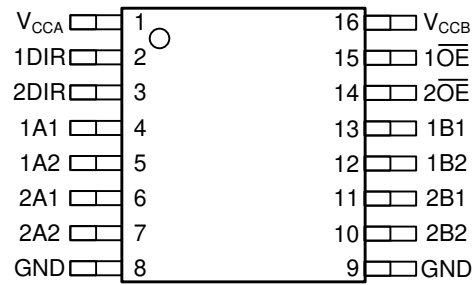

Figure 4-2. PW Package, 16-Pin TSSOP (Top View)

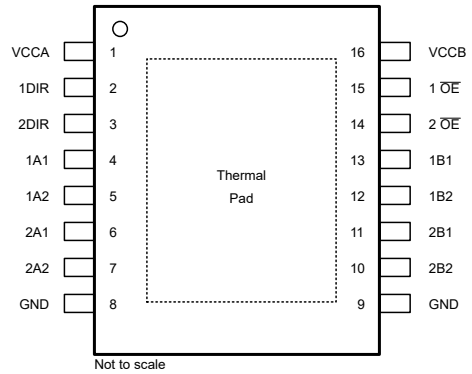

Figure 4-4. DYY Package, 16-Pin SOT (Top View)

Table 4-1. Pin Functions

PIN		TYPE ⁽¹⁾	DESCRIPTION
NAME	NO.		
1A1	4	I/O	Input/output 1A1. Referenced to V_{CCA} .
1A2	5	I/O	Input/output 1A2. Referenced to V_{CCA} .
1B1	13	I/O	Input/output 1B1. Referenced to V_{CCB} .
1B2	12	I/O	Input/output 1B2. Referenced to V_{CCB} .
1DIR	2	I	Direction-control input for 1 ports
1 \overline{OE}	15	I	3-state output-mode enable. Pull \overline{OE} high to place '1' outputs in 3-state mode. Referenced to V_{CCA} .
2A1	6	I/O	Input/output 2A1. Referenced to V_{CCA} .
2A2	7	I/O	Input/output 2A2. Referenced to V_{CCA} .
2B1	11	I/O	Input/output 2B1. Referenced to V_{CCB} .
2B2	10	I/O	Input/output 2B2. Referenced to V_{CCB} .
2DIR	3	I	Direction-control input for 2 ports
2 \overline{OE}	14	I	3-state output-mode enable. Pull \overline{OE} high to place '2' outputs in 3-state mode. Referenced to V_{CCA} .
GND	8, 9	—	Ground
V_{CCA}	1	I	A-port power supply voltage. $1.2V \leq V_{CCA} \leq 3.6V$
V_{CCB}	16	I	B-port power supply voltage. $1.2V \leq V_{CCB} \leq 3.6V$
Thermal pad		—	The exposed thermal pad must be connected as a secondary GND or be left electrically open.

(1) I = input, O = output

5 Specifications

5.1 Absolute Maximum Ratings

over operating ambient temperature range (unless otherwise noted) ⁽¹⁾

		MIN	MAX	UNIT	
V_{CCA} V_{CCB}	Supply voltage	-0.5	4.6	V	
V_I	Input voltage ⁽²⁾	I/O ports (A port)	-0.5	4.6	V
		I/O ports (B port)	-0.5	4.6	
		Control inputs	-0.5	4.6	
V_O	Voltage applied to any output in the high-impedance or power-off state ⁽²⁾	A port	-0.5	4.6	V
		B port	-0.5	4.6	
V_O	Voltage applied to any output in the high or low state ^{(2) (3)}	A port	-0.5	$V_{CCA} + 0.5$	V
		B port	-0.5	$V_{CCB} + 0.5$	
I_{IK}	Input clamp current	$V_I < 0$	-50	mA	
I_{OK}	Output clamp current	$V_O < 0$	-50	mA	
I_O	Continuous output current		±50	mA	
	Continuous current through V_{CCA} , V_{CCB} , or GND		±100	mA	
T_{stg}	Storage temperature	-65	150	°C	

(1) Stresses beyond those listed under *Absolute Maximum Ratings* may cause permanent damage to the device. These are stress ratings only, and do not imply functional operation of the device at these or any other conditions beyond those indicated under *Recommended Operating Conditions*. Exposure to absolute-maximum-rated conditions for extended periods may affect device reliability.

(2) The input voltage and output negative-voltage ratings may be exceeded if the input and output current ratings are observed.

(3) The output positive-voltage rating may be exceeded up to 4.6V maximum if the output current rating is observed.

5.2 ESD Ratings

		VALUE	UNIT	
$V_{(ESD)}$	Electrostatic discharge	Human body model (HBM), per ANSI/ESDA/JEDEC JS-001, all pins ⁽¹⁾	±8000	V
		Charged device model (CDM), per JEDEC specification JESD22-C101, all pins ⁽²⁾	±1000	
		Machine model (C101)	±150	

(1) JEDEC document JEP155 states that 500V HBM allows safe manufacturing with a standard ESD control process.

(2) JEDEC document JEP157 states that 250V CDM allows safe manufacturing with a standard ESD control process.

5.3 Recommended Operating Conditions

		V_{CCI}	V_{CCO}	MIN	MAX	UNIT
V_{CCA}	Supply voltage			1.2	3.6	V
V_{CCB}	Supply voltage			1.2	3.6	V
V_{IH}	High-level input voltage	Data inputs ⁽¹⁾	1.2V to 1.95V	$V_{CCI} \times 0.65$		V
			1.95V to 2.7V	1.6		
			2.7V to 3.6V	2		
V_{IL}	Low-level input voltage	Data inputs ⁽¹⁾	1.2V to 1.95V	$V_{CCI} \times 0.35$		V
			1.95V to 2.7V	0.7		
			2.7V to 3.6V	0.8		
V_{IH}	High-level input voltage	DIR (referenced to V_{CCA}) ⁽²⁾	1.2V to 1.95V	$V_{CCA} \times 0.65$		V
			1.95V to 2.7V	1.6		
			2.7V to 3.6V	2		

5.3 Recommended Operating Conditions (continued)

			V _{CCI}	V _{CCO}	MIN	MAX	UNIT
V _{IL}	Low-level input voltage	DIR (referenced to V _{CCA}) ⁽²⁾	1.2V to 1.95V			V _{CCA} × 0.35	V
			1.95V to 2.7V			0.7	
			2.7V to 3.6V			0.8	
V _I	Input voltage				0	3.6	V
V _O	Output voltage	Active state			0	V _{CCO}	V
		3-state			0	3.6	
I _{OH}	High-level output current			1.2V		-3	mA
				1.4V to 1.6V		-6	
				1.65V to 1.95V		-8	
				2.3V to 2.7V		-9	
				3V to 3.6V		-12	
I _{OL}	Low-level output current			1.1V to 1.2V		3	mA
				1.4V to 1.6V		6	
				1.65V to 1.95V		8	
				2.3V to 2.7V		9	
				3V to 3.6V		12	
Δt/Δv	Input transition rise or fall rate					5	ns/V
T _A	Operating ambient temperature				-40	125	°C

- (1) For V_{CCI} values not specified in the data sheet, V_{IH} min = V_{CCI} × 0.7V, V_{IL} max = V_{CCI} × 0.3V
(2) For V_{CCI} values not specified in the data sheet, V_{IH} min = V_{CCA} × 0.7V, V_{IL} max = V_{CCA} × 0.3V

5.4 Thermal Information

THERMAL METRIC ⁽¹⁾		SN74AVC4T245-Q1				UNIT
		RGY (VQFN)	PW (TSSOP)	BQB (WQFN)	DYY (SOT)	
		16 PINS	16 PINS	16 PINS	16 PINS	
R _{θJA}	Junction-to-ambient thermal resistance	68.8	101.8	80.8	163.4	°C/W
R _{θJC(top)}	Junction-to-case (top) thermal resistance	70.6	37.2	77.9	90.0	°C/W
R _{θJB}	Junction-to-board thermal resistance	45	60.6	50.7	93.1	°C/W
ψ _{JT}	Junction-to-top characterization parameter	11.9	1.6	7.4	10.9	°C/W
ψ _{JB}	Junction-to-board characterization parameter	44.7	60.0	50.6	92.1	°C/W
R _{θJC(bot)}	Junction-to-case (bottom) thermal resistance	28.2	N/A	28.4	N/A	°C/W

- (1) For more information about traditional and new thermal metrics, see the [Semiconductor and IC Package Thermal Metrics](#) application note.

5.5 Electrical Characteristics

over recommended operating ambient temperature range (unless otherwise noted)

PARAMETER		TEST CONDITIONS	V _{CCA}	V _{CCB}	T _A	MIN	TYP	MAX	UNIT
V _{OH}		V _I = V _{IH}	1.2V to 3.6V	1.2V to 3.6V	T _A = -40°C to 125°C	V _{CCO} - 0.2			V
			1.2V	1.2V	T _A = 25°C	0.95			
			1.4V	1.4V	T _A = -40°C to 125°C	1.05			
			1.65V	1.65V	T _A = -40°C to 125°C	1.2			
			2.3V	2.3V	T _A = -40°C to 125°C	1.75			
			3V	3V	T _A = -40°C to 125°C	2.3			
V _{OL}		V _I = V _{IL}	1.2V to 3.6V	1.2V to 3.6V	T _A = -40°C to 125°C			0.2	V
			1.2V	1.2V	T _A = 25°C	0.25			
			1.4V	1.4V	T _A = -40°C to 125°C	0.35			
			1.65V	1.65V	T _A = -40°C to 125°C	0.45			
			2.3V	2.3V	T _A = -40°C to 125°C	0.55			
			3V	3V	T _A = -40°C to 125°C	0.7			
I _I ⁽¹⁾	Control inputs	V _I = V _{CCA} or GND	1.2V to 3.6V	1.2V to 3.6V	T _A = 25°C	±0.025	±0.25		μA
					T _A = -40°C to 125°C	±1.5			
I _{off}	A or B port	V _I or V _O = 0 to 3.6V	0V	0V to 3.6V	T _A = 25°C	±0.1	±1		μA
					T _A = -40°C to 125°C	±5			
			0V to 3.6V	0V	T _A = 25°C	±0.1	±1		
					T _A = -40°C to 125°C	±5			
I _{oz}	A or B port	V _O = V _{CCO} or GND, V _I = V _{CC1} or GND, \overline{OE} = V _{IH}	3.6V	3.6V	T _A = 25°C	±0.5	±2.5		μA
					T _A = -40°C to 125°C	±5			
I _{CCA} ⁽¹⁾		V _I = V _{CC1} or GND, I _O = 0	1.2V to 3.6V	1.2V to 3.6V	T _A = -40°C to 125°C	8			μA
					T _A = 25°C	-2			
			0V	0V to 3.6V	T _A = -40°C to 125°C	-11			
I _{CCB} ⁽¹⁾		V _I = V _{CC1} or GND, I _O = 0	1.2V to 3.6V	1.2V to 3.6V	T _A = -40°C to 125°C	8			μA
					T _A = -40°C to 125°C	8			
			0V to 3.6V	0V	T _A = 25°C	-2			
					T _A = -40°C to 125°C	-11			
I _{CCA} + I _{CCB}		V _I = V _{CC1} or GND, I _O = 0	1.2V to 3.6V	1.2V to 3.6V	T _A = -40°C to 125°C	16			μA

5.5 Electrical Characteristics (continued)

over recommended operating ambient temperature range (unless otherwise noted)

PARAMETER		TEST CONDITIONS	V _{CCA}	V _{CCB}	T _A	MIN	TYP	MAX	UNIT
C _i	Control inputs	V _I = 3.3V or GND	3.3V	3.3V	T _A = 25°C	3.5	4.5		pF
					T _A = -40°C to 125°C		7		
C _{io}	A or B port	V _O = 3.3V or GND	3.3V	3.3V	T _A = 25°C		6		pF
					T _A = -40°C to 125°C				

- (1) All unused data inputs of the device must be held at V_{CCI} or GND for proper device operation. See the TI application report, *Implications of Slow or Floating CMOS Inputs*, [SCBA004](#).

5.6 Switching Characteristics: V_{CCA} = 1.2V

over recommended operating ambient temperature range, V_{CCA} = 1.2V (unless otherwise noted) (see [Figure 6-1](#))

PARAMETER	FROM (INPUT)	TO (OUTPUT)	V _{CCB}	TYP	UNIT
t _{PHL} , t _{PLH}	A	B	V _{CCB} = 1.2V	3.4	ns
			V _{CCB} = 1.5V ± 0.1V	2.9	
			V _{CCB} = 1.8V ± 0.15V	2.7	
			V _{CCB} = 2.5V ± 0.2V	2.6	
			V _{CCB} = 3.3V ± 0.3V	2.8	
t _{PHL} , t _{PLH}	B	A	V _{CCB} = 1.2V	3.6	ns
			V _{CCB} = 1.5V ± 0.1V	3.1	
			V _{CCB} = 1.8V ± 0.15V	2.8	
			V _{CCB} = 2.5V ± 0.2V	2.6	
			V _{CCB} = 3.3V ± 0.3V	2.6	
t _{PHZ} , t _{PLZ}	\overline{OE}	A	V _{CCB} = 1.2V	5.6	ns
			V _{CCB} = 1.5V ± 0.1V	4.7	
			V _{CCB} = 1.8V ± 0.15V	4.3	
			V _{CCB} = 2.5V ± 0.2V	3.9	
			V _{CCB} = 3.3V ± 0.3V	3.7	
t _{PZH}	\overline{OE}	B	V _{CCB} = 1.2V	5	ns
			V _{CCB} = 1.5V ± 0.1V	4.3	
			V _{CCB} = 1.8V ± 0.15V	3.9	
			V _{CCB} = 2.5V ± 0.2V	3.6	
			V _{CCB} = 3.3V ± 0.3V	36.6	
t _{PZL}	\overline{OE}	B	V _{CCB} = 1.2V	5	ns
			V _{CCB} = 1.5V ± 0.1V	4.3	
			V _{CCB} = 1.8V ± 0.15V	3.9	
			V _{CCB} = 2.5V ± 0.2V	3.6	
			V _{CCB} = 3.3V ± 0.3V	3.6	
t _{PHZ} , t _{PLZ}	\overline{OE}	A	V _{CCB} = 1.2V	6.2	ns
			V _{CCB} = 1.5V ± 0.1V	5.2	
			V _{CCB} = 1.8V ± 0.15V	5.2	
			V _{CCB} = 2.5V ± 0.2V	4.3	
			V _{CCB} = 3.3V ± 0.3V	4.8	

5.6 Switching Characteristics: $V_{CCA} = 1.2V$ (continued)

over recommended operating ambient temperature range, $V_{CCA} = 1.2V$ (unless otherwise noted) (see Figure 6-1)

PARAMETER	FROM (INPUT)	TO (OUTPUT)	V_{CCB}	TYP	UNIT
t_{PHZ} , t_{PLZ}	\overline{OE}	B	$V_{CCB} = 1.2V$	5.9	ns
			$V_{CCB} = 1.5V \pm 0.1V$	5.1	
			$V_{CCB} = 1.8V \pm 0.15V$	5	
			$V_{CCB} = 2.5V \pm 0.2V$	4.7	
			$V_{CCB} = 3.3V \pm 0.3V$	5.5	

5.7 Switching Characteristics, $V_{CCA} = 1.5V \pm 0.1V$

over recommended operating ambient temperature range, $V_{CCA} = 1.5V \pm 0.1V$ (see Figure 6-1)

PARAMETER	FROM (INPUT)	TO (OUTPUT)	V_{CCB}	MIN	TYP	MAX	UNIT
t_{PLH} , t_{PHL}	A	B	$V_{CCB} = 1.2V$		3.2		ns
			$V_{CCB} = 1.5V \pm 0.1V$			11.3	
			$V_{CCB} = 1.8V \pm 0.15V$			10.2	
			$V_{CCB} = 2.5V \pm 0.2V$			9.2	
			$V_{CCB} = 3.3V \pm 0.3V$			9.2	
t_{PLH} , t_{PHL}	B	A	$V_{CCB} = 1.2V$		3.3		ns
			$V_{CCB} = 1.5V \pm 0.1V$			11.3	
			$V_{CCB} = 1.8V \pm 0.15V$			11	
			$V_{CCB} = 2.5V \pm 0.2V$			10.7	
			$V_{CCB} = 3.3V \pm 0.3V$			10.6	
t_{PZH} , t_{PZL}	\overline{OE}	A	$V_{CCB} = 1.2V$		4.9		ns
			$V_{CCB} = 1.5V \pm 0.1V$			14.6	
			$V_{CCB} = 1.8V \pm 0.15V$			14.5	
			$V_{CCB} = 2.5V \pm 0.2V$			14.4	
			$V_{CCB} = 3.3V \pm 0.3V$			14.4	
t_{PZH} , t_{PZL}	\overline{OE}	B	$V_{CCB} = 1.2V$		4.5		ns
			$V_{CCB} = 1.5V \pm 0.1V$			14.6	
			$V_{CCB} = 1.8V \pm 0.15V$			12.7	
			$V_{CCB} = 2.5V \pm 0.2V$			10.8	
			$V_{CCB} = 3.3V \pm 0.3V$			10.6	
t_{PZH} , t_{PZL}	\overline{OE}	A	$V_{CCB} = 1.2V$		5.6		ns
			$V_{CCB} = 1.5V \pm 0.1V$			15.2	
			$V_{CCB} = 1.8V \pm 0.15V$			15.2	
			$V_{CCB} = 2.5V \pm 0.2V$			15.2	
			$V_{CCB} = 3.3V \pm 0.3V$			15.2	
t_{PZH} , t_{PZL}	\overline{OE}	B	$V_{CCB} = 1.2V$		5.2		ns
			$V_{CCB} = 1.5V \pm 0.1V$			15.3	
			$V_{CCB} = 1.8V \pm 0.15V$			14.1	
			$V_{CCB} = 2.5V \pm 0.2V$			12.4	
			$V_{CCB} = 3.3V \pm 0.3V$			12.6	

5.8 Switching Characteristics: $V_{CCA} = 1.8V \pm 0.15V$

over recommended operating ambient temperature range, $V_{CCA} = 1.8V \pm 0.15V$ (see Figure 6-1)

PARAMETER	FROM (INPUT)	TO (OUTPUT)	V_{CCB}	MIN	TYP	MAX	UNIT
t_{PLH}, t_{PHL}	A	B	$V_{CCB} = 1.2V$		2.9		ns
			$V_{CCB} = 1.5V \pm 0.1V$			11	
			$V_{CCB} = 1.8V \pm 0.15V$			9.9	
			$V_{CCB} = 2.5V \pm 0.2V$			8.9	
			$V_{CCB} = 3.3V \pm 0.3V$			8.9	
t_{PLH}, t_{PHL}	B	A	$V_{CCB} = 1.2V$		3		ns
			$V_{CCB} = 1.5V \pm 0.1V$			10.3	
			$V_{CCB} = 1.8V \pm 0.15V$			9.9	
			$V_{CCB} = 2.5V \pm 0.2V$			9.6	
			$V_{CCB} = 3.3V \pm 0.3V$			9.5	
t_{PZH}, t_{PZL}	\overline{OE}	A	$V_{CCB} = 1.2V$		4.4		ns
			$V_{CCB} = 1.5V \pm 0.1V$			12.4	
			$V_{CCB} = 1.8V \pm 0.15V$			12.3	
			$V_{CCB} = 2.5V \pm 0.2V$			12.3	
			$V_{CCB} = 3.3V \pm 0.3V$			12.2	
t_{PZH}, t_{PZL}	\overline{OE}	B	$V_{CCB} = 1.2V$		4.1		ns
			$V_{CCB} = 1.5V \pm 0.1V$			14.2	
			$V_{CCB} = 1.8V \pm 0.15V$			12.4	
			$V_{CCB} = 2.5V \pm 0.2V$			10.3	
			$V_{CCB} = 3.3V \pm 0.3V$			9.6	
t_{PZH}, t_{PZL}	\overline{OE}	A	$V_{CCB} = 1.2V$		5.4		ns
			$V_{CCB} = 1.5V \pm 0.1V$			13.6	
			$V_{CCB} = 1.8V \pm 0.15V$			13.7	
			$V_{CCB} = 2.5V \pm 0.2V$			13.7	
			$V_{CCB} = 3.3V \pm 0.3V$			13.7	
t_{PZH}, t_{PZL}	\overline{OE}	B	$V_{CCB} = 1.2V$		5		ns
			$V_{CCB} = 1.5V \pm 0.1V$			14.9	
			$V_{CCB} = 1.8V \pm 0.15V$			13.7	
			$V_{CCB} = 2.5V \pm 0.2V$			11.9	
			$V_{CCB} = 3.3V \pm 0.3V$			11.9	

5.9 Switching Characteristics: $V_{CCA} = 2.5V \pm 0.2V$

over recommended operating ambient temperature range, $V_{CCA} = 2.5V \pm 0.2V$ (see Figure 6-1)

PARAMETER	FROM (INPUT)	TO (OUTPUT)	V_{CCB}	MIN	TYP	MAX	UNIT
t_{PLH}, t_{PHL}	A	B	$V_{CCB} = 1.2V$		2.8		ns
			$V_{CCB} = 1.5V \pm 0.1V$			10.7	
			$V_{CCB} = 1.8V \pm 0.15V$			9.6	
			$V_{CCB} = 2.5V \pm 0.2V$			8.5	
			$V_{CCB} = 3.3V \pm 0.3V$			8.6	

5.9 Switching Characteristics: $V_{CCA} = 2.5V \pm 0.2V$ (continued)

over recommended operating ambient temperature range, $V_{CCA} = 2.5V \pm 0.2V$ (see [Figure 6-1](#))

PARAMETER	FROM (INPUT)	TO (OUTPUT)	V_{CCB}	MIN	TYP	MAX	UNIT
t_{PLH} , t_{PHL}	B	A	$V_{CCB} = 1.2V$		2.7		ns
			$V_{CCB} = 1.5V \pm 0.1V$			9.2	
			$V_{CCB} = 1.8V \pm 0.15V$			8.9	
			$V_{CCB} = 2.5V \pm 0.2V$			8.4	
			$V_{CCB} = 3.3V \pm 0.3V$			8.3	
t_{PZH} , t_{PZL}	\overline{OE}	A	$V_{CCB} = 1.2V$		4		ns
			$V_{CCB} = 1.5V \pm 0.1V$			11.5	
			$V_{CCB} = 1.8V \pm 0.15V$			10.2	
			$V_{CCB} = 2.5V \pm 0.2V$			9.8	
			$V_{CCB} = 3.3V \pm 0.3V$			9.8	
t_{PZH} , t_{PZL}	\overline{OE}	B	$V_{CCB} = 1.2V$		3.8		ns
			$V_{CCB} = 1.5V \pm 0.1V$			13.8	
			$V_{CCB} = 1.8V \pm 0.15V$			12	
			$V_{CCB} = 2.5V \pm 0.2V$			9.8	
			$V_{CCB} = 3.3V \pm 0.3V$			9	
t_{PHZ} , t_{PLZ}	\overline{OE}	A	$V_{CCB} = 1.2V$		4.7		ns
			$V_{CCB} = 1.5V \pm 0.1V$			13.4	
			$V_{CCB} = 1.8V \pm 0.15V$			13.4	
			$V_{CCB} = 2.5V \pm 0.2V$			11.2	
			$V_{CCB} = 3.3V \pm 0.3V$			11.5	
t_{PHZ} , t_{PLZ}	\overline{OE}	B	$V_{CCB} = 1.2V$		4.5		ns
			$V_{CCB} = 1.5V \pm 0.1V$			14.4	
			$V_{CCB} = 1.8V \pm 0.15V$			13.2	
			$V_{CCB} = 2.5V \pm 0.2V$			11.2	
			$V_{CCB} = 3.3V \pm 0.3V$			10.2	

5.10 Switching Characteristics: $V_{CCA} = 3.3V \pm 0.3V$

over recommended operating ambient temperature range, $V_{CCA} = 3.3V \pm 0.3V$ (see [Figure 6-1](#))

PARAMETER	FROM (INPUT)	TO (OUTPUT)	V_{CCB}	MIN	TYP	MAX	UNIT
t_{PLH} , t_{PHL}	A	B	$V_{CCB} = 1.2V$		2.9		ns
			$V_{CCB} = 1.5V \pm 0.1V$			10.6	
			$V_{CCB} = 1.8V \pm 0.15V$			9.5	
			$V_{CCB} = 2.5V \pm 0.2V$			8.3	
			$V_{CCB} = 3.3V \pm 0.3V$			7.9	
t_{PLH} , t_{PHL}	B	A	$V_{CCB} = 1.2V$		2.6		ns
			$V_{CCB} = 1.5V \pm 0.1V$			9.2	
			$V_{CCB} = 1.8V \pm 0.15V$			8.4	
			$V_{CCB} = 2.5V \pm 0.2V$			8	
			$V_{CCB} = 3.3V \pm 0.3V$			7.8	

5.10 Switching Characteristics: $V_{CCA} = 3.3V \pm 0.3V$ (continued)

over recommended operating ambient temperature range, $V_{CCA} = 3.3V \pm 0.3V$ (see [Figure 6-1](#))

PARAMETER	FROM (INPUT)	TO (OUTPUT)	V_{CCB}	MIN	TYP	MAX	UNIT
t_{PHZ}, t_{PLZ}	\overline{OE}	A	$V_{CCB} = 1.2V$		3.8		ns
			$V_{CCB} = 1.5V \pm 0.1V$			13.7	
			$V_{CCB} = 1.8V \pm 0.15V$			10.2	
			$V_{CCB} = 2.5V \pm 0.2V$			8.8	
			$V_{CCB} = 3.3V \pm 0.3V$			8.8	
t_{PHZ}, t_{PLZ}	\overline{OE}	B	$V_{CCB} = 1.2V$		3.7		ns
			$V_{CCB} = 1.5V \pm 0.1V$			13.7	
			$V_{CCB} = 1.8V \pm 0.15V$			11.8	
			$V_{CCB} = 2.5V \pm 0.2V$			9.7	
			$V_{CCB} = 3.3V \pm 0.3V$			8.8	
t_{PHZ}, t_{PLZ}	\overline{OE}	A	$V_{CCB} = 1.2V$		4.8		ns
			$V_{CCB} = 1.5V \pm 0.1V$			14.3	
			$V_{CCB} = 1.8V \pm 0.15V$			13.3	
			$V_{CCB} = 2.5V \pm 0.2V$			10.6	
			$V_{CCB} = 3.3V \pm 0.3V$			11.6	
t_{PHZ}, t_{PLZ}	\overline{OE}	B	$V_{CCB} = 1.2V$		5.3		ns
			$V_{CCB} = 1.5V \pm 0.1V$			14.3	
			$V_{CCB} = 1.8V \pm 0.15V$			13.1	
			$V_{CCB} = 2.5V \pm 0.2V$			11.4	
			$V_{CCB} = 3.3V \pm 0.3V$			11.2	

5.11 Operating Characteristics

T_A = 25°C

PARAMETER			TEST CONDITIONS	V _{CCA}	TYP	UNIT		
C _{pdA} ⁽¹⁾	A to B	Outputs enabled	C _L = 0, f = 10MHz, t _r = t _f = 1ns	V _{CCA} = V _{CCB} = 1.2V	1	pF		
				V _{CCA} = V _{CCB} = 1.5V	1			
				V _{CCA} = V _{CCB} = 1.8V	1			
				V _{CCA} = V _{CCB} = 2.5V	1.5			
				V _{CCA} = V _{CCB} = 3.3V	2			
				V _{CCA} = V _{CCB} = 1.2V	1			
	V _{CCA} = V _{CCB} = 1.5V							
	V _{CCA} = V _{CCB} = 1.8V							
	V _{CCA} = V _{CCB} = 2.5V							
	V _{CCA} = V _{CCB} = 3.3V							
	B to A	Outputs enabled	C _L = 0, f = 10MHz, t _r = t _f = 1ns	C _L = 0, f = 10MHz, t _r = t _f = 1ns	V _{CCA} = V _{CCB} = 1.2V		12	
					V _{CCA} = V _{CCB} = 1.5V		12.5	
					V _{CCA} = V _{CCB} = 1.8V		13	
					V _{CCA} = V _{CCB} = 2.5V		14	
					V _{CCA} = V _{CCB} = 3.3V		15	
		Outputs disabled	C _L = 0, f = 10MHz, t _r = t _f = 1ns	C _L = 0, f = 10MHz, t _r = t _f = 1ns	C _L = 0, f = 10MHz, t _r = t _f = 1ns		V _{CCA} = V _{CCB} = 1.2V	1
							V _{CCA} = V _{CCB} = 1.5V	
							V _{CCA} = V _{CCB} = 1.8V	
V _{CCA} = V _{CCB} = 2.5V								
V _{CCA} = V _{CCB} = 3.3V								
C _{pdB} ⁽¹⁾	A to B	Outputs enabled	C _L = 0, f = 10MHz, t _r = t _f = 1ns	V _{CCA} = V _{CCB} = 1.2V	12	pF		
				V _{CCA} = V _{CCB} = 1.5V	12.5			
				V _{CCA} = V _{CCB} = 1.8V	13			
				V _{CCA} = V _{CCB} = 2.5V	14			
				V _{CCA} = V _{CCB} = 3.3V	15			
				V _{CCA} = V _{CCB} = 1.2V	1			
	V _{CCA} = V _{CCB} = 1.5V							
	V _{CCA} = V _{CCB} = 1.8V							
	V _{CCA} = V _{CCB} = 2.5V							
	V _{CCA} = V _{CCB} = 3.3V							
	B to A	Outputs enabled	C _L = 0, f = 10MHz, t _r = t _f = 1ns	C _L = 0, f = 10MHz, t _r = t _f = 1ns	V _{CCA} = V _{CCB} = 1.2V		1	
					V _{CCA} = V _{CCB} = 1.5V		1	
					V _{CCA} = V _{CCB} = 1.8V		1	
					V _{CCA} = V _{CCB} = 2.5V		1	
					V _{CCA} = V _{CCB} = 3.3V		2	
		Outputs disabled	C _L = 0, f = 10MHz, t _r = t _f = 1ns	C _L = 0, f = 10MHz, t _r = t _f = 1ns	C _L = 0, f = 10MHz, t _r = t _f = 1ns		V _{CCA} = V _{CCB} = 1.2V	1
							V _{CCA} = V _{CCB} = 1.5V	
							V _{CCA} = V _{CCB} = 1.8V	
V _{CCA} = V _{CCB} = 2.5V								
V _{CCA} = V _{CCB} = 3.3V								

(1) Power dissipation capacitance per transceiver

5.12 Typical Characteristics

T_A = 25°C

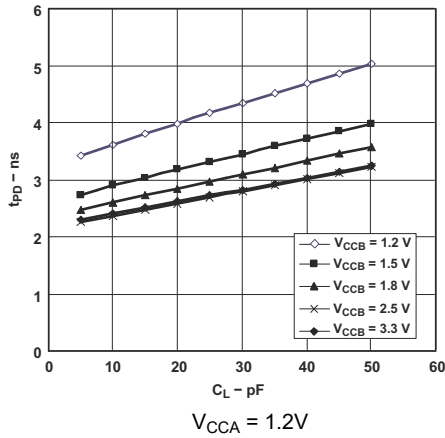

Figure 5-1. Typical Propagation Delay (A to B) vs Load Capacitance

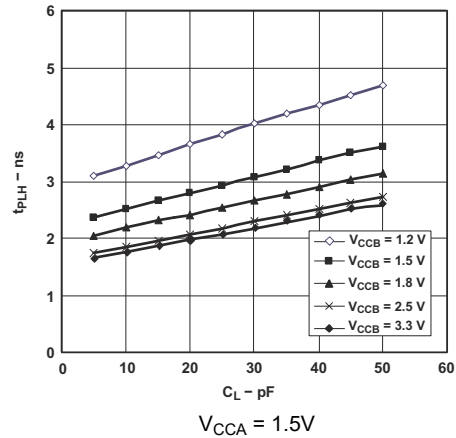

Figure 5-2. Typical Propagation Delay (A to B) vs Load Capacitance

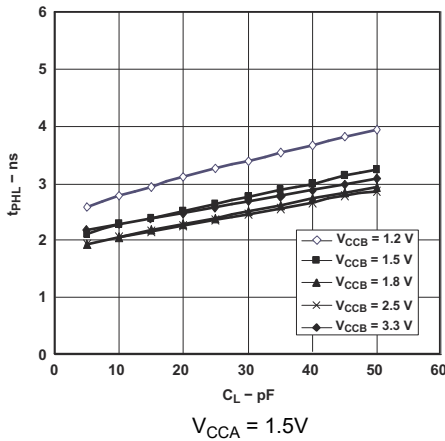

Figure 5-3. Typical Propagation Delay (A to B) vs Load Capacitance

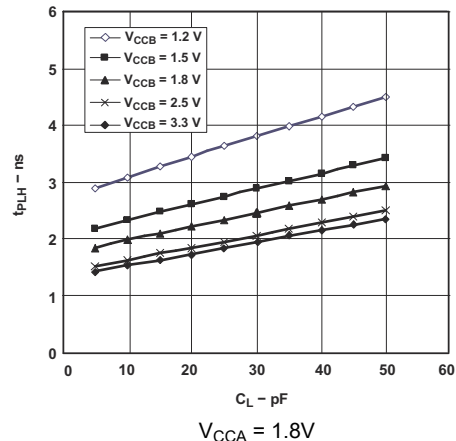

Figure 5-4. Typical Propagation Delay (A to B) vs Load Capacitance

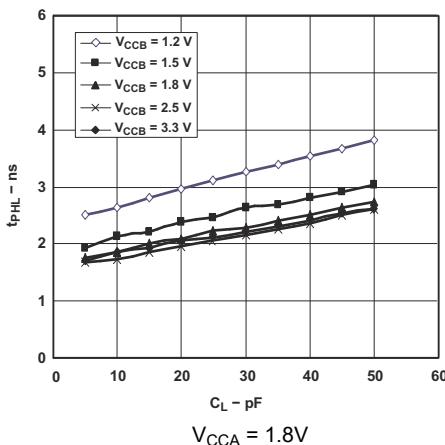

Figure 5-5. Typical Propagation Delay (A to B) vs Load Capacitance

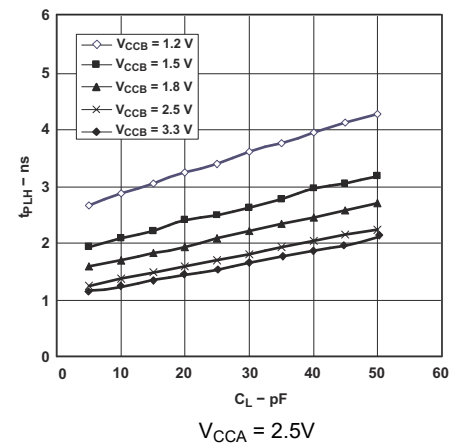

Figure 5-6. Typical Propagation Delay (A to B) vs Load Capacitance

5.12 Typical Characteristics (continued)

T_A = 25°C

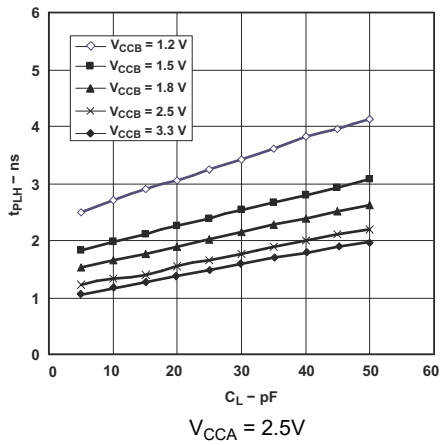

Figure 5-7. Typical Propagation Delay (A to B) vs Load Capacitance

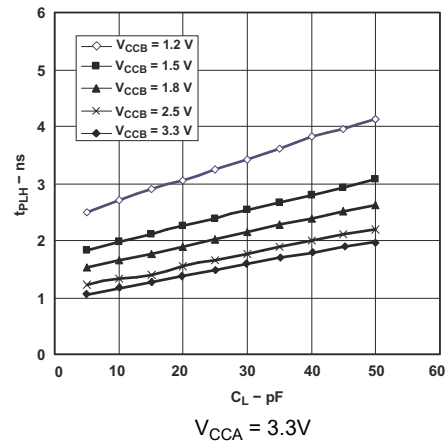

Figure 5-8. Typical Propagation Delay (A to B) vs Load Capacitance

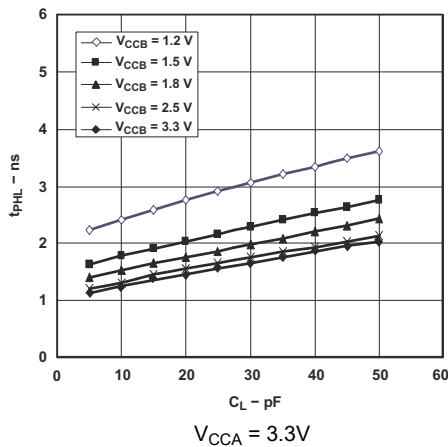

Figure 5-9. Typical Propagation Delay (A to B) vs Load Capacitance

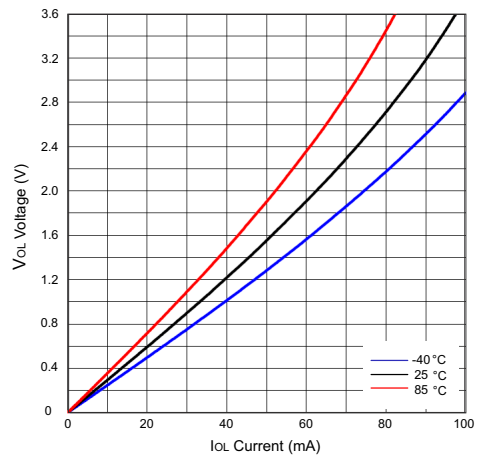

Figure 5-10. Low-Level Output Voltage (VOL) vs Low-Level Current (IOL)

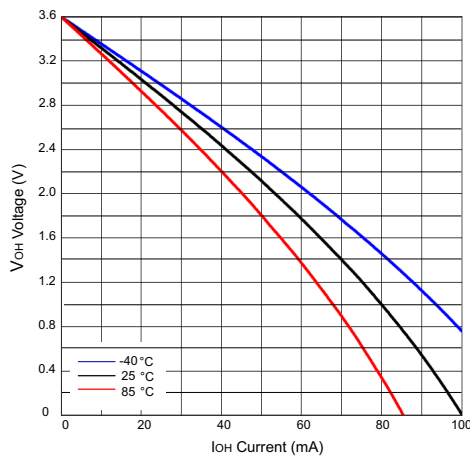
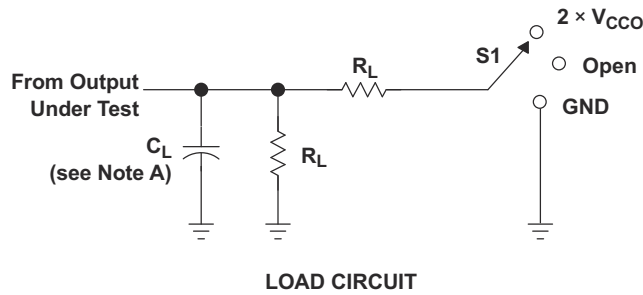

Figure 5-11. High-Level Output Voltage (VOH) vs High-Level Current (IOH)

6 Parameter Measurement Information



TEST	S1
t_{pd}	Open
t_{PLZ}/t_{PZL}	$2 \times V_{CCO}$
t_{PHZ}/t_{PZH}	GND

V_{CCO}	C_L	R_L	V_{TP}
1.2 V	15 pF	2 k Ω	0.1 V
1.5 V \pm 0.1 V	15 pF	2 k Ω	0.1 V
1.8 V \pm 0.15 V	15 pF	2 k Ω	0.15 V
2.5 V \pm 0.2 V	15 pF	2 k Ω	0.15 V
3.3 V \pm 0.3 V	15 pF	2 k Ω	0.3 V

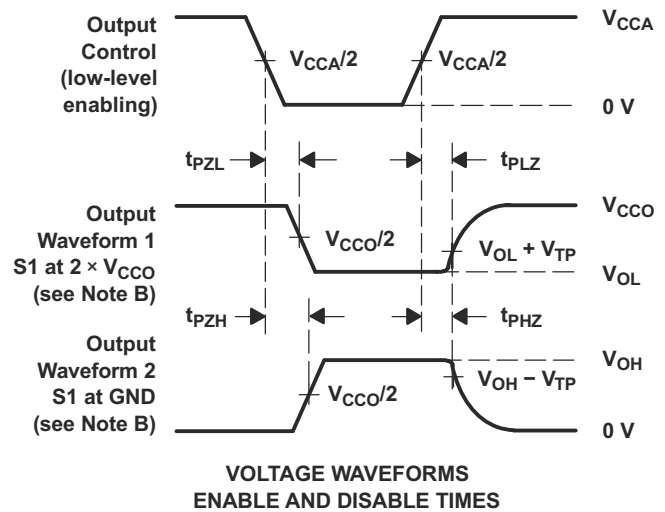
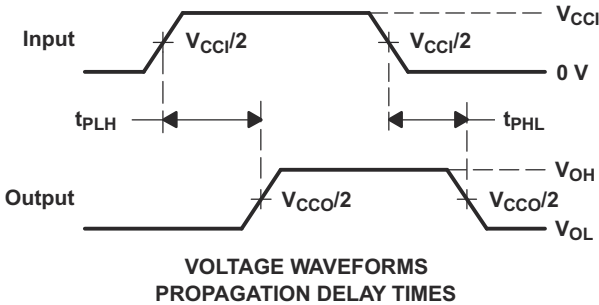
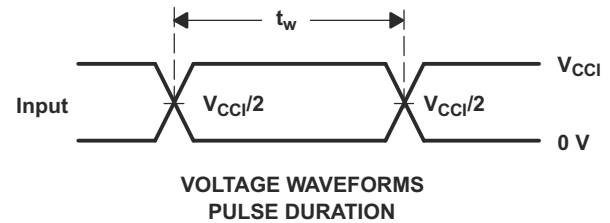

- NOTES:
- C_L includes probe and jig capacitance.
 - Waveform 1 is for an output with internal conditions such that the output is low except when disabled by the output control. Waveform 2 is for an output with internal conditions such that the output is high, except when disabled by the output control.
 - All input pulses are supplied by generators having the following characteristics: $PRR \leq 10$ MHz, $Z_O = 50 \Omega$, $dv/dt \geq 1$ V/ns.
 - The outputs are measured one at a time, with one transition per measurement.
 - t_{PLZ} and t_{PHZ} are the same as t_{dis} .
 - t_{PZL} and t_{PZH} are the same as t_{en} .
 - t_{PLH} and t_{PHL} are the same as t_{pd} .
 - V_{CCI} is the V_{CC} associated with the input port.
 - V_{CCO} is the V_{CC} associated with the output port.

Figure 6-1. Load and Circuit and Voltage Waveforms

7 Detailed Description

7.1 Overview

The SN74AVC4T245-Q1 is a 4-bit, dual-supply noninverting bidirectional voltage level translation device. Ax pins and control pins (1DIR, 2DIR, 1 $\overline{\text{OE}}$, and 2 $\overline{\text{OE}}$) are supported by V_{CCA} , and Bx pins are supported by V_{CCB} . The A port is able to accept I/O voltages ranging from 1.2V to 3.6V, while the B port can accept I/O voltages from 1.2V to 3.6V. A high on DIR allows data transmission from Ax to Bx and a low on DIR allows data transmission from Bx to Ax when $\overline{\text{OE}}$ is set to low. When $\overline{\text{OE}}$ is set to high, both Ax and Bx pins are in the high-impedance state.

7.2 Functional Block Diagram

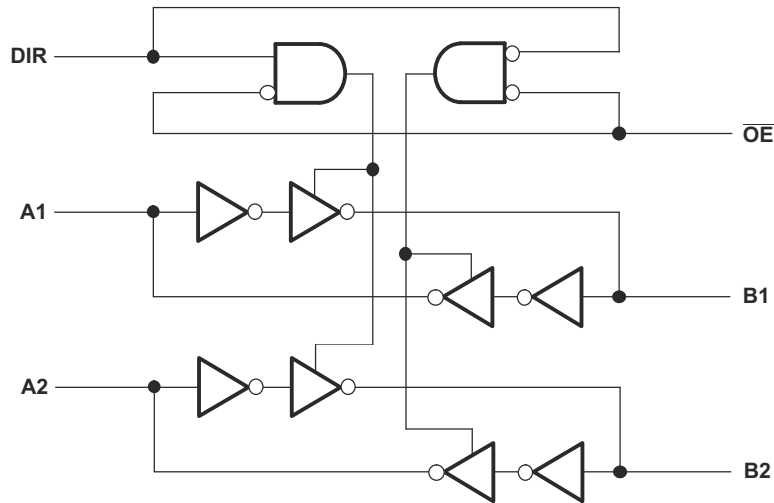

Figure 7-1. Logic Diagram (Positive Logic) for 1/2 of SN74AVC4T245-Q1

7.3 Feature Description

7.3.1 Fully Configurable Dual-Rail Design

Both V_{CCA} and V_{CCB} can be supplied at any voltage between 1.2V and 3.6V; thus, making the device suitable for translating between any of the low voltage nodes (1.2V, 1.8V, 2.5V, and 3.3V).

7.3.2 Supports High Speed Translation

The SN74AVC4T245-Q1 device can support high data rate applications. The translated signal data rate can be up to 380Mbps when the signal is translated from 1.8V to 3.3V.

7.3.3 I_{off} Supports Partial-Power-Down Mode Operation

I_{off} prevents backflow current by disabling I/O output circuits when the device is in partial-power-down mode.

7.4 Device Functional Modes

Table 7-1 lists the functional modes of the SN74AVC4T245-Q1 device.

**Table 7-1. Function Table
(Each 2-Bit Section)**

CONTROL INPUTS		OUTPUT CIRCUITS		OPERATION
\overline{OE}	DIR	A PORT	B PORT	
L	L	Enabled	Hi-Z	B data to A bus
L	H	Hi-Z	Enabled	A data to B bus
H	X	Hi-Z	Hi-Z	Isolation

8 Application and Implementation

Note

Information in the following applications sections is not part of the TI component specification, and TI does not warrant its accuracy or completeness. TI's customers are responsible for determining suitability of components for their purposes, as well as validating and testing their design implementation to confirm system functionality.

8.1 Application Information

The SN74AVC4T245-Q1 device can be used in level-translation applications for interfacing devices or systems operating at different interface voltages with one another. The SN74AVC4T245-Q1 device is ideal for use in applications where a push-pull driver is connected to the data I/Os. The maximum data rate can be up to 380Mbps when the device translates a signal from 1.8V to 3.3V.

8.2 Typical Application

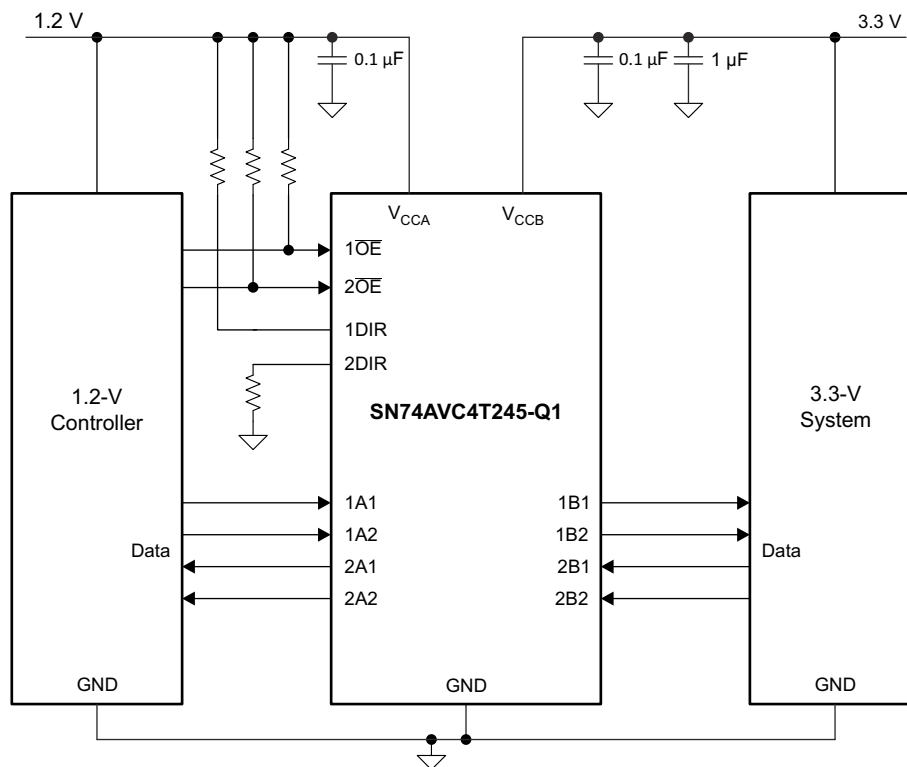

Figure 8-1. Typical Application Diagram

8.2.1 Design Requirements

Table 8-1 lists the parameters for this design example.

Table 8-1. Design Parameters

DESIGN PARAMETER	EXAMPLE VALUE
Input voltage range	1.2V
Output voltage range	3.3V

8.2.2 Detailed Design Procedure

To begin the design process, determine the following:

- Input voltage range
 - Use the supply voltage of the device that is driving the SN74AVC4T245-Q1 device to determine the input voltage range. For a valid logic high, the value must exceed the V_{IH} of the input port. For a valid logic low, the value must be less than the V_{IL} of the input port. For this example, the input voltage is 1.2V.
- Output voltage range
 - Use the supply voltage of the device that the SN74AVC4T245-Q1 device is driving to determine the output voltage range. For this example, the output voltage is 3.3V.

8.2.3 Application Curve

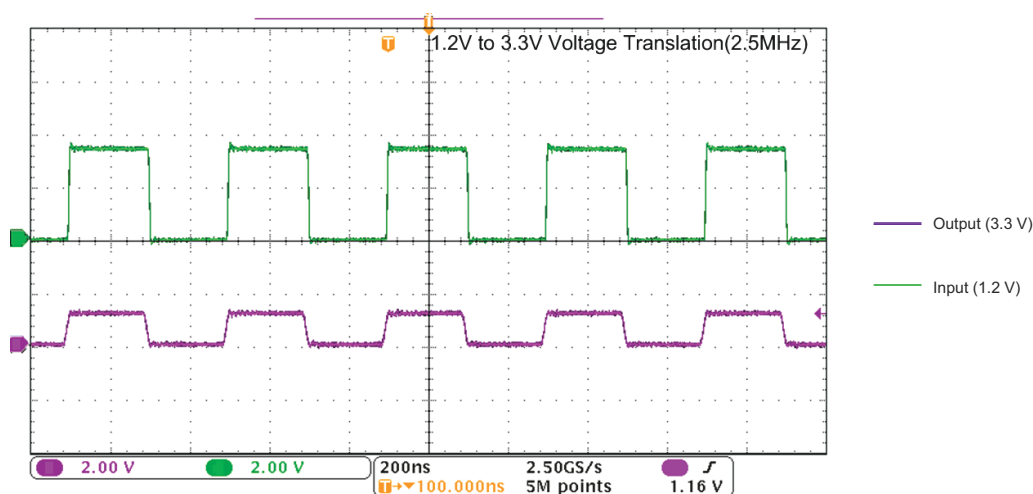

Figure 8-2. Translation Up (1.2V to 3.3V) at 2.5MHz

8.3 Power Supply Recommendations

The SN74AVC4T245-Q1 device uses two separate configurable power-supply rails: V_{CCA} and V_{CCB} . V_{CCA} accepts any supply voltage from 1.2V to 3.6V, and V_{CCB} accepts any supply voltage from 1.2V to 3.6V. The A port and B port are designed to track V_{CCA} and V_{CCB} respectively, allowing for low-voltage bidirectional translation between any of the 1.2V, 1.5V, 1.8V, 2.5V, and 3.3V voltage nodes.

The output-enable (\overline{OE}) input circuit is designed so that it is supplied by V_{CCA} ; when the \overline{OE} input is high, all outputs are placed in the high-impedance state. To place the outputs in the high-impedance state during power up or power down, tie the \overline{OE} input pin to V_{CCA} through a pullup resistor and do not enable it until V_{CCA} and V_{CCB} are fully ramped and stable. The minimum value of the pullup resistor to V_{CCA} is determined by the current-sinking capability of the driver.

8.4 Layout

8.4.1 Layout Guidelines

For device reliability, it is recommended to follow common printed-circuit board layout guidelines such as:

- Use bypass capacitors on power supplies.
- Use short trace lengths to avoid excessive loading.
- Place pads on the signal paths for loading capacitors or pullup resistors to help adjust rise and fall times of signals, depending on the system requirements.

8.4.2 Layout Example

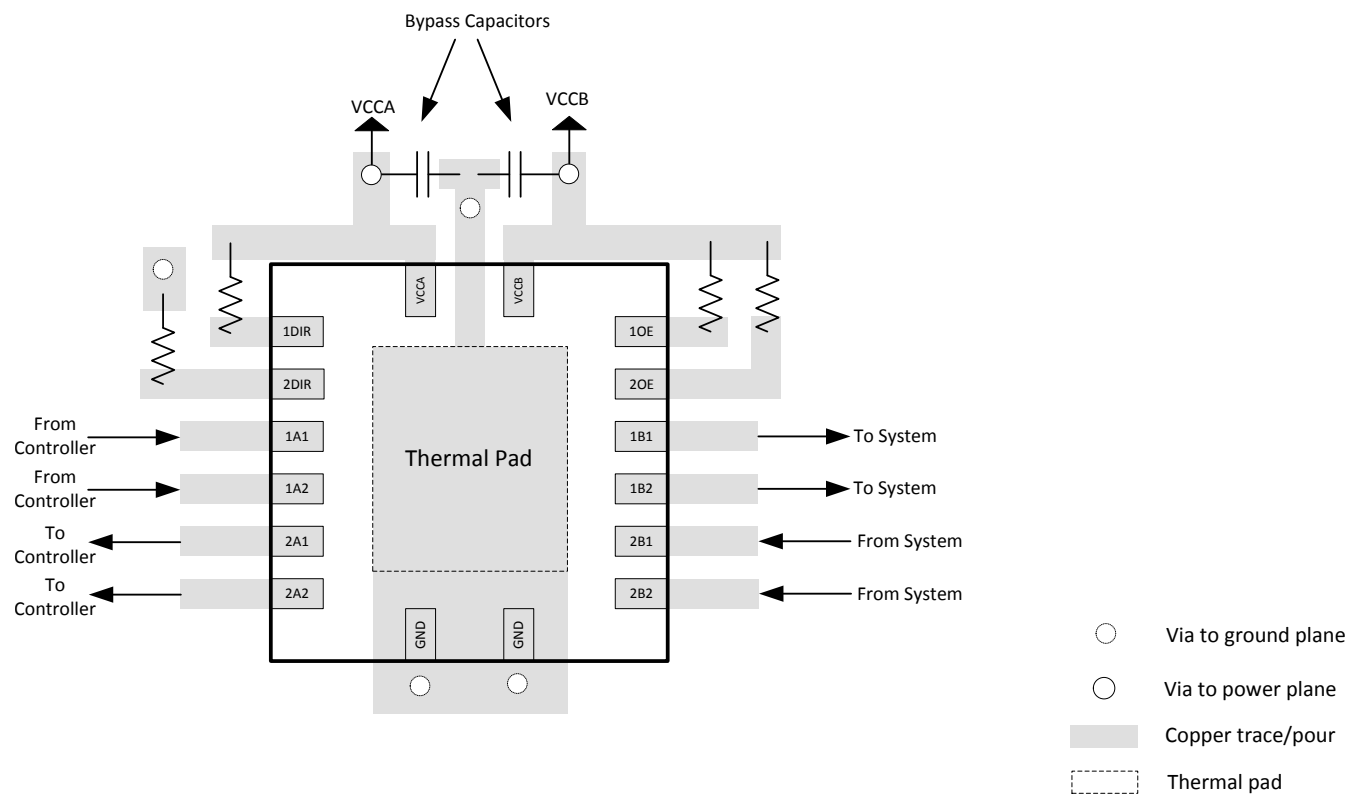

Figure 8-3. SN74AVC4T245-Q1 RGY Package Layout Diagram

9 Device and Documentation Support

9.1 Documentation Support

9.1.1 Related Documentation

For related documentation, see the following:

- Texas Instruments, [IC Package Thermal Metrics](#)
- Texas Instruments, [Implications of Slow or Floating CMOS Inputs](#)

9.2 Receiving Notification of Documentation Updates

To receive notification of documentation updates, navigate to the device product folder on ti.com. Click on *Notifications* to register and receive a weekly digest of any product information that has changed. For change details, review the revision history included in any revised document.

9.3 Support Resources

[TI E2E™ support forums](#) are an engineer's go-to source for fast, verified answers and design help — straight from the experts. Search existing answers or ask your own question to get the quick design help you need.

Linked content is provided "AS IS" by the respective contributors. They do not constitute TI specifications and do not necessarily reflect TI's views; see TI's [Terms of Use](#).

9.4 Trademarks

TI E2E™ is a trademark of Texas Instruments.
All trademarks are the property of their respective owners.

9.5 Electrostatic Discharge Caution



This integrated circuit can be damaged by ESD. Texas Instruments recommends that all integrated circuits be handled with appropriate precautions. Failure to observe proper handling and installation procedures can cause damage.

ESD damage can range from subtle performance degradation to complete device failure. Precision integrated circuits may be more susceptible to damage because very small parametric changes could cause the device not to meet its published specifications.

9.6 Glossary

[TI Glossary](#) This glossary lists and explains terms, acronyms, and definitions.

10 Revision History

NOTE: Page numbers for previous revisions may differ from page numbers in the current version.

Changes from Revision C (February 2024) to Revision D (May 2026)	Page
• Updated the <i>Thermal Information</i> for the <i>RGY</i> package.....	7

Changes from Revision B (March 2016) to Revision C (February 2024)	Page
• Added Functional safety link to Features list	1
• Updated the Package Information table to include package lead size	1
• Added the <i>PW</i> , <i>BQB</i> , and <i>DYY</i> packages.....	1

11 Mechanical, Packaging, and Orderable Information

The following pages include mechanical, packaging, and orderable information. This information is the most-current data available for the designated device. This data is subject to change without notice and without revision of this document. For browser-based versions of this data sheet, see the left-hand navigation pane.

PACKAGING INFORMATION

Orderable part number	Status (1)	Material type (2)	Package Pins	Package qty Carrier	RoHS (3)	Lead finish/ Ball material (4)	MSL rating/ Peak reflow (5)	Op temp (°C)	Part marking (6)
74AVC4T245QDYRQ1	Active	Production	SOT-23-THIN (DYY) 16	3000 LARGE T&R	Yes	NIPDAU	Level-1-260C-UNLIM	-40 to 125	WT245Q
74AVC4T245QDYRQ1.A	Active	Production	SOT-23-THIN (DYY) 16	3000 LARGE T&R	Yes	NIPDAU	Level-1-260C-UNLIM	-40 to 125	WT245Q
74AVC4T245QPWRQ1	Active	Production	TSSOP (PW) 16	3000 LARGE T&R	Yes	NIPDAU	Level-1-260C-UNLIM	-40 to 125	WT245Q
74AVC4T245QPWRQ1.A	Active	Production	TSSOP (PW) 16	3000 LARGE T&R	Yes	NIPDAU	Level-1-260C-UNLIM	-40 to 125	WT245Q
74AVC4T245QRGYRQ1	Active	Production	VQFN (RGY) 16	3000 LARGE T&R	Yes	NIPDAU	Level-3-260C-168 HR	-40 to 125	4T245Q
74AVC4T245QRGYRQ1.A	Active	Production	VQFN (RGY) 16	3000 LARGE T&R	Yes	NIPDAU	Level-3-260C-168 HR	-40 to 125	4T245Q
74AVC4T245QRGYRQ1.B	Active	Production	VQFN (RGY) 16	3000 LARGE T&R	Yes	NIPDAU	Level-3-260C-168 HR	-40 to 125	4T245Q
74AVC4T245QWBQBRQ1	Active	Production	WQFN (BQB) 16	3000 LARGE T&R	Yes	NIPDAU	Level-1-260C-UNLIM	-40 to 125	WT245Q
74AVC4T245QWBQBRQ1.A	Active	Production	WQFN (BQB) 16	3000 LARGE T&R	Yes	NIPDAU	Level-1-260C-UNLIM	-40 to 125	WT245Q
74AVC4T245RGYRQ1G4	Active	Production	VQFN (RGY) 16	3000 LARGE T&R	Yes	NIPDAU	Level-3-260C-168 HR	-40 to 125	4T245Q
74AVC4T245RGYRQ1G4.A	Active	Production	VQFN (RGY) 16	3000 LARGE T&R	Yes	NIPDAU	Level-3-260C-168 HR	-40 to 125	4T245Q
74AVC4T245RGYRQ1G4.B	Active	Production	VQFN (RGY) 16	3000 LARGE T&R	Yes	NIPDAU	Level-3-260C-168 HR	-40 to 125	4T245Q

(1) **Status:** For more details on status, see our [product life cycle](#).

(2) **Material type:** When designated, preproduction parts are prototypes/experimental devices, and are not yet approved or released for full production. Testing and final process, including without limitation quality assurance, reliability performance testing, and/or process qualification, may not yet be complete, and this item is subject to further changes or possible discontinuation. If available for ordering, purchases will be subject to an additional waiver at checkout, and are intended for early internal evaluation purposes only. These items are sold without warranties of any kind.

(3) **RoHS values:** Yes, No, RoHS Exempt. See the [TI RoHS Statement](#) for additional information and value definition.

(4) **Lead finish/Ball material:** Parts may have multiple material finish options. Finish options are separated by a vertical ruled line. Lead finish/Ball material values may wrap to two lines if the finish value exceeds the maximum column width.

(5) **MSL rating/Peak reflow:** The moisture sensitivity level ratings and peak solder (reflow) temperatures. In the event that a part has multiple moisture sensitivity ratings, only the lowest level per JEDEC standards is shown. Refer to the shipping label for the actual reflow temperature that will be used to mount the part to the printed circuit board.

(6) **Part marking:** There may be an additional marking, which relates to the logo, the lot trace code information, or the environmental category of the part.

Multiple part markings will be inside parentheses. Only one part marking contained in parentheses and separated by a "~" will appear on a part. If a line is indented then it is a continuation of the previous line and the two combined represent the entire part marking for that device.

Important Information and Disclaimer: The information provided on this page represents TI's knowledge and belief as of the date that it is provided. TI bases its knowledge and belief on information provided by third parties, and makes no representation or warranty as to the accuracy of such information. Efforts are underway to better integrate information from third parties. TI has taken and continues to take reasonable steps to provide representative and accurate information but may not have conducted destructive testing or chemical analysis on incoming materials and chemicals. TI and TI suppliers consider certain information to be proprietary, and thus CAS numbers and other limited information may not be available for release.

In no event shall TI's liability arising out of such information exceed the total purchase price of the TI part(s) at issue in this document sold by TI to Customer on an annual basis.

OTHER QUALIFIED VERSIONS OF SN74AVC4T245-Q1 :

- Catalog : [SN74AVC4T245](#)

NOTE: Qualified Version Definitions:

- Catalog - TI's standard catalog product

TAPE AND REEL INFORMATION

QUADRANT ASSIGNMENTS FOR PIN 1 ORIENTATION IN TAPE

*All dimensions are nominal

Device	Package Type	Package Drawing	Pins	SPQ	Reel Diameter (mm)	Reel Width W1 (mm)	A0 (mm)	B0 (mm)	K0 (mm)	P1 (mm)	W (mm)	Pin1 Quadrant
74AVC4T245QDYRQ1	SOT-23-THIN	DYY	16	3000	330.0	12.4	4.8	3.6	1.6	8.0	12.0	Q3
74AVC4T245QPWRQ1	TSSOP	PW	16	3000	330.0	12.4	6.9	5.6	1.6	8.0	12.0	Q1
74AVC4T245QRGYRQ1	VQFN	RGY	16	3000	330.0	12.4	3.8	4.3	1.5	8.0	12.0	Q1
74AVC4T245QWBQRQ1	WQFN	BQB	16	3000	180.0	12.4	2.8	3.8	1.2	4.0	12.0	Q1
74AVC4T245RGYRQ1G4	VQFN	RGY	16	3000	330.0	12.4	3.8	4.3	1.5	8.0	12.0	Q1

TAPE AND REEL BOX DIMENSIONS

*All dimensions are nominal

Device	Package Type	Package Drawing	Pins	SPQ	Length (mm)	Width (mm)	Height (mm)
74AVC4T245QDYRQ1	SOT-23-THIN	DYY	16	3000	336.6	336.6	31.8
74AVC4T245QPWRQ1	TSSOP	PW	16	3000	353.0	353.0	32.0
74AVC4T245QRGYRQ1	VQFN	RGY	16	3000	353.0	353.0	32.0
74AVC4T245QWBQRQ1	WQFN	BQB	16	3000	210.0	185.0	35.0
74AVC4T245RGYRQ1G4	VQFN	RGY	16	3000	353.0	353.0	32.0

GENERIC PACKAGE VIEW

BQB 16

WQFN - 0.8 mm max height

2.5 x 3.5, 0.5 mm pitch

PLASTIC QUAD FLATPACK - NO LEAD

This image is a representation of the package family, actual package may vary.
Refer to the product data sheet for package details.

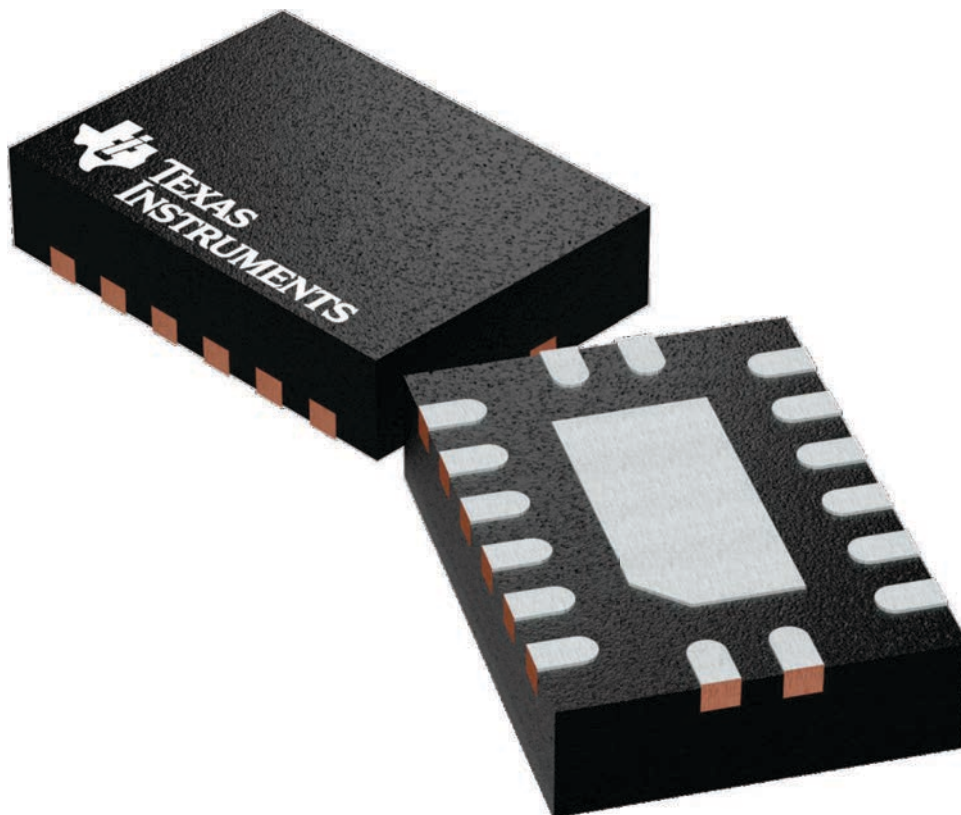

4226161/A

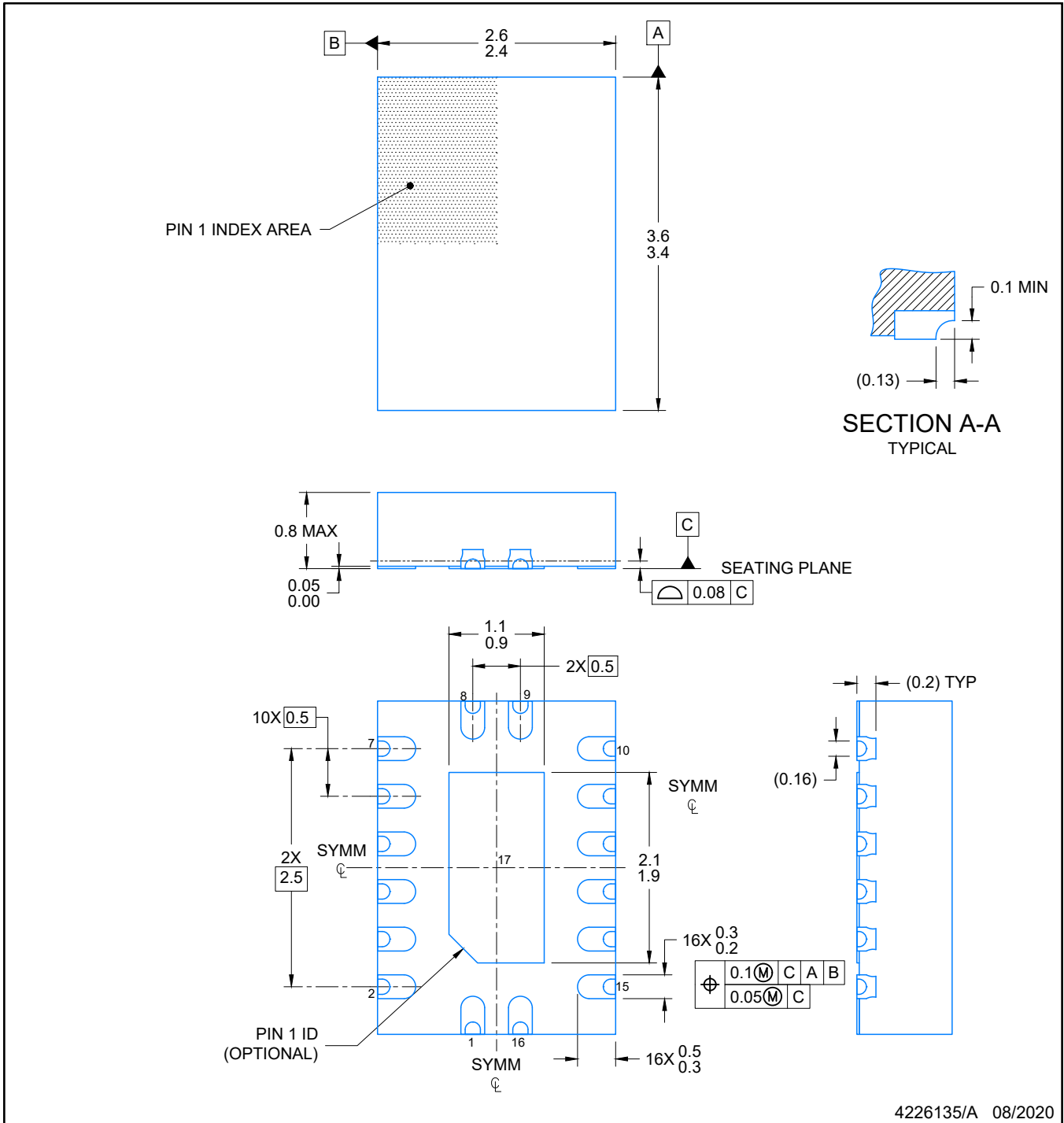

4226135/A 08/2020

NOTES:

1. All linear dimensions are in millimeters. Any dimensions in parenthesis are for reference only. Dimensioning and tolerancing per ASME Y14.5M.
2. This drawing is subject to change without notice.
3. The package thermal pad must be soldered to the printed circuit board for optimal thermal and mechanical performance.

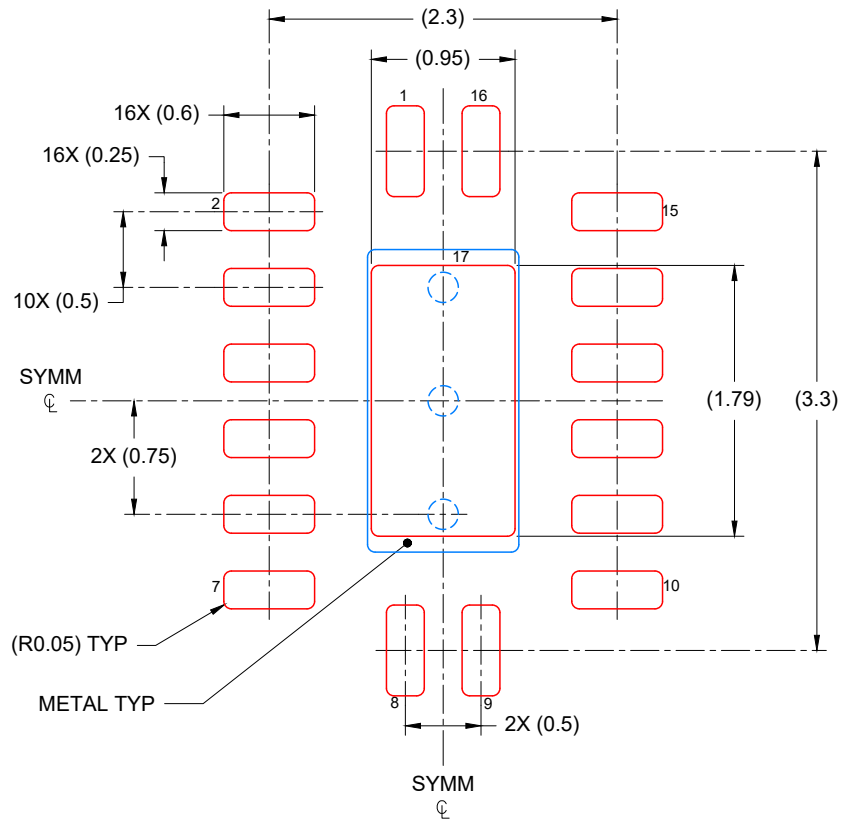

SOLDER PASTE EXAMPLE
 BASED ON 0.125 mm THICK STENCIL

EXPOSED PAD
 85% PRINTED COVERAGE BY AREA
 SCALE: 20X

4226135/A 08/2020

NOTES: (continued)

- 6. Laser cutting apertures with trapezoidal walls and rounded corners may offer better paste release. IPC-7525 may have alternate design recommendations.

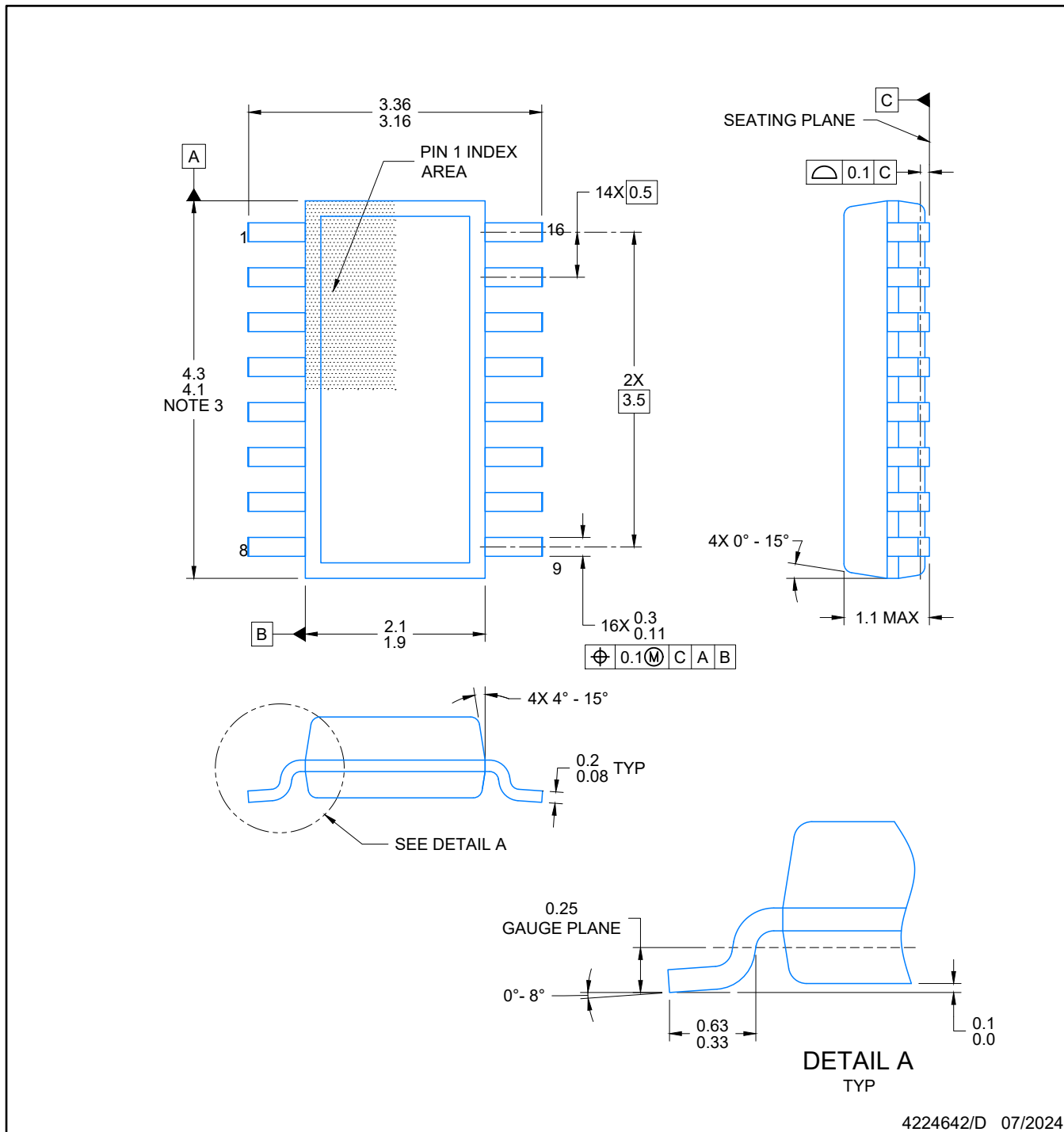

4224642/D 07/2024

NOTES:

1. All linear dimensions are in millimeters. Any dimensions in parenthesis are for reference only. Dimensioning and tolerancing per ASME Y14.5M.
2. This drawing is subject to change without notice.
3. This dimension does not include mold flash, protrusions, or gate burrs. Mold flash, protrusions, or gate burrs shall not exceed 0.15 per side.
4. This dimension does not include interlead flash. Interlead flash shall not exceed 0.50 per side.
5. Reference JEDEC Registration MO-345, Variation AA

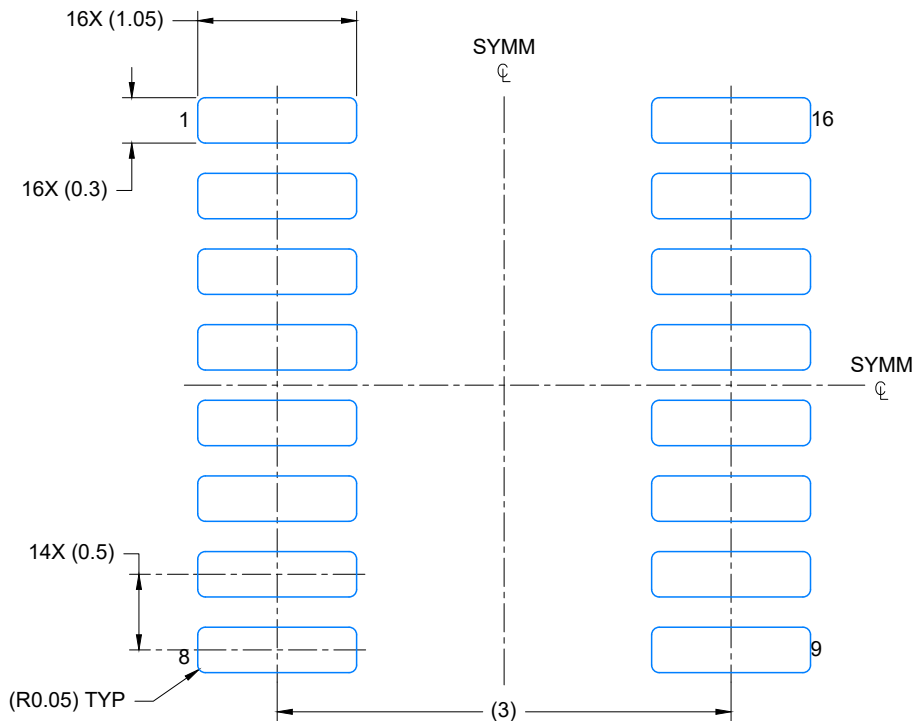

LAND PATTERN EXAMPLE
EXPOSED METAL SHOWN
SCALE: 20X

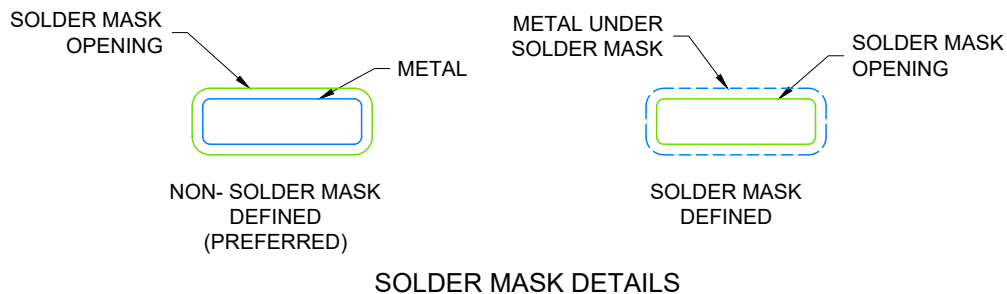

4224642/D 07/2024

NOTES: (continued)

- 6. Publication IPC-7351 may have alternate designs.
- 7. Solder mask tolerances between and around signal pads can vary based on board fabrication site.

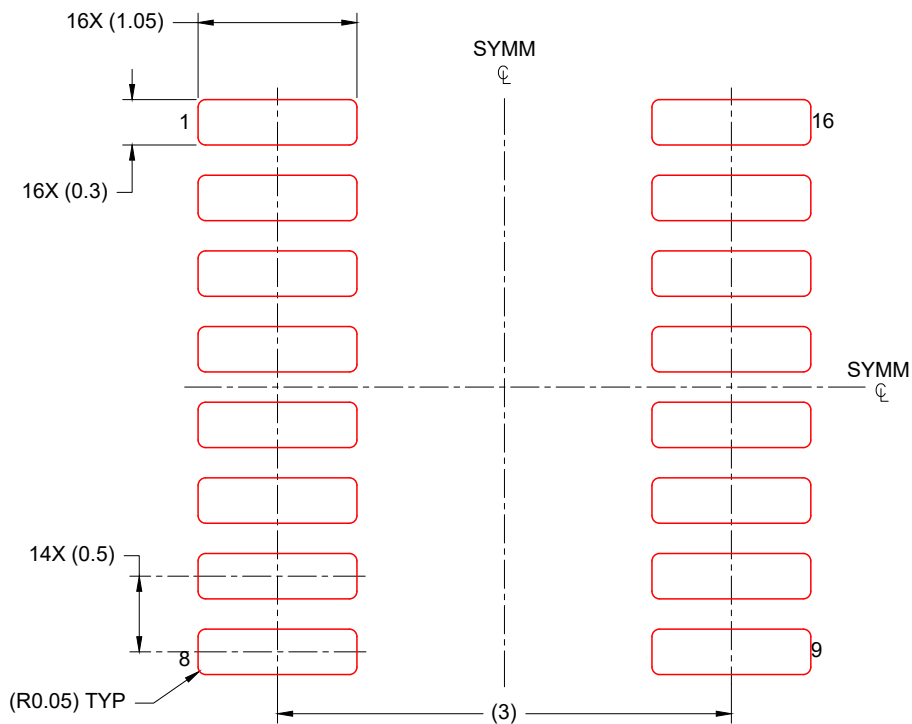

SOLDER PASTE EXAMPLE
BASED ON 0.125 mm THICK STENCIL
SCALE: 20X

4224642/D 07/2024

NOTES: (continued)

- 8. Laser cutting apertures with trapezoidal walls and rounded corners may offer better paste release. IPC-7525 may have alternate design recommendations.
- 9. Board assembly site may have different recommendations for stencil design.

RGY (R-PVQFN-N16)

PLASTIC QUAD FLATPACK NO-LEAD

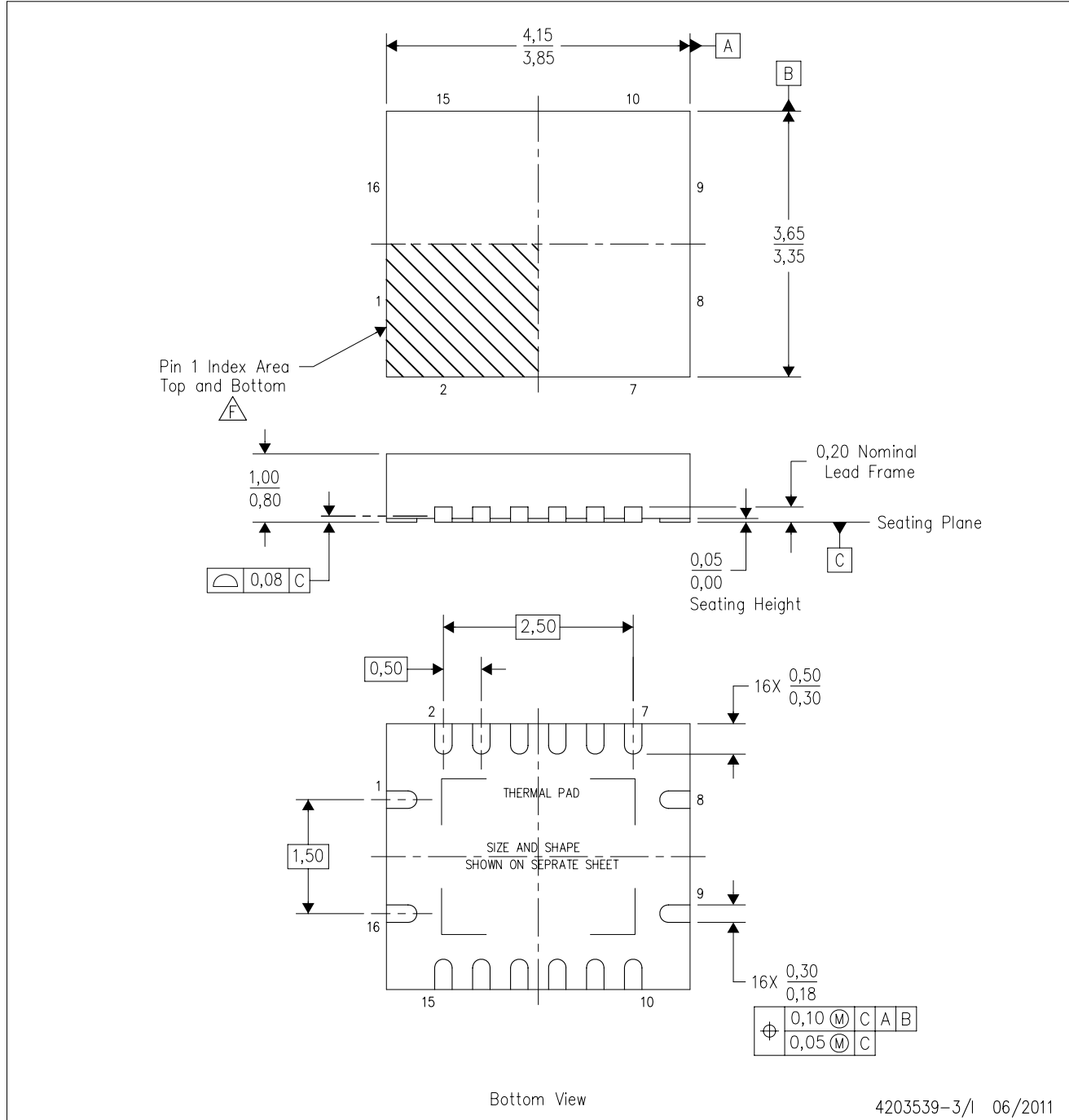

- NOTES:
- A. All linear dimensions are in millimeters. Dimensioning and tolerancing per ASME Y14.5M-1994.
 - B. This drawing is subject to change without notice.
 - C. QFN (Quad Flatpack No-Lead) package configuration.
 - D. The package thermal pad must be soldered to the board for thermal and mechanical performance.
 - E. See the additional figure in the Product Data Sheet for details regarding the exposed thermal pad features and dimensions.
 - F. Pin 1 identifiers are located on both top and bottom of the package and within the zone indicated. The Pin 1 identifiers are either a molded, marked, or metal feature.
 - G. Package complies to JEDEC MO-241 variation BA.

RGY (R-PVQFN-N16)

PLASTIC QUAD FLATPACK NO-LEAD

THERMAL INFORMATION

This package incorporates an exposed thermal pad that is designed to be attached directly to an external heatsink. The thermal pad must be soldered directly to the printed circuit board (PCB). After soldering, the PCB can be used as a heatsink. In addition, through the use of thermal vias, the thermal pad can be attached directly to the appropriate copper plane shown in the electrical schematic for the device, or alternatively, can be attached to a special heatsink structure designed into the PCB. This design optimizes the heat transfer from the integrated circuit (IC).

For information on the Quad Flatpack No-Lead (QFN) package and its advantages, refer to Application Report, QFN/SON PCB Attachment, Texas Instruments Literature No. SLUA271. This document is available at www.ti.com.

The exposed thermal pad dimensions for this package are shown in the following illustration.

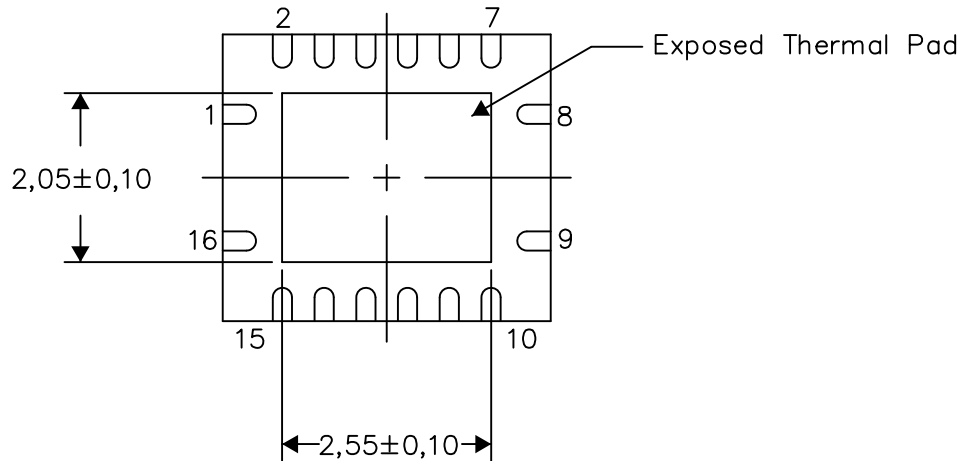

Bottom View

Exposed Thermal Pad Dimensions

4206353-3/P 03/14

NOTE: All linear dimensions are in millimeters

RGY (R-PVQFN-N16)

PLASTIC QUAD FLATPACK NO-LEAD

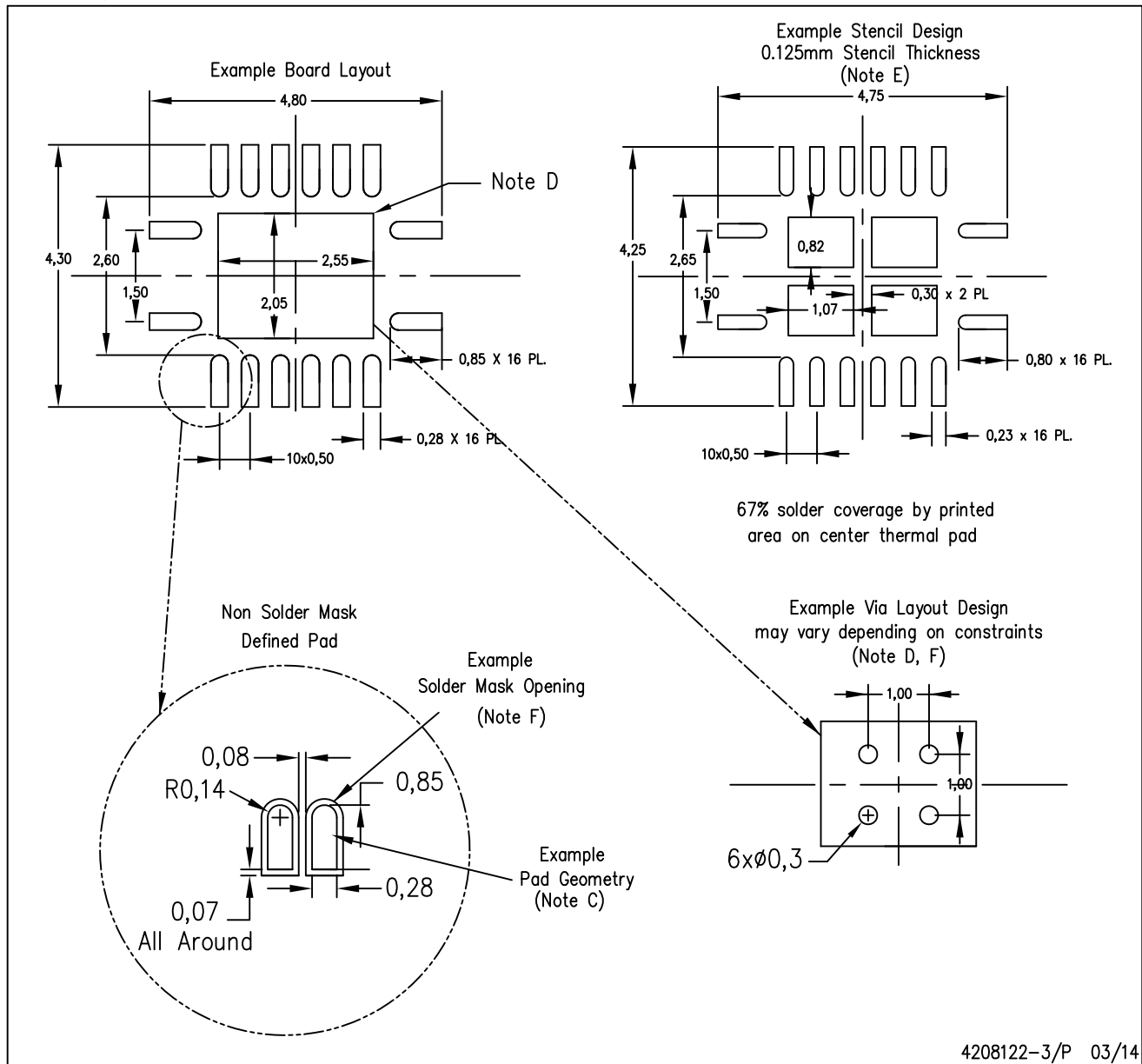

- NOTES:
- A. All linear dimensions are in millimeters.
 - B. This drawing is subject to change without notice.
 - C. Publication IPC-7351 is recommended for alternate designs.
 - D. This package is designed to be soldered to a thermal pad on the board. Refer to Application Note, Quad Flat-Pack QFN/SON PCB Attachment, Texas Instruments Literature No. SLUA271, and also the Product Data Sheets for specific thermal information, via requirements, and recommended board layout. These documents are available at www.ti.com <<http://www.ti.com>>.
 - E. Laser cutting apertures with trapezoidal walls and also rounding corners will offer better paste release. Customers should contact their board assembly site for stencil design recommendations. Refer to IPC 7525 for stencil design considerations.
 - F. Customers should contact their board fabrication site for minimum solder mask web tolerances between signal pads.

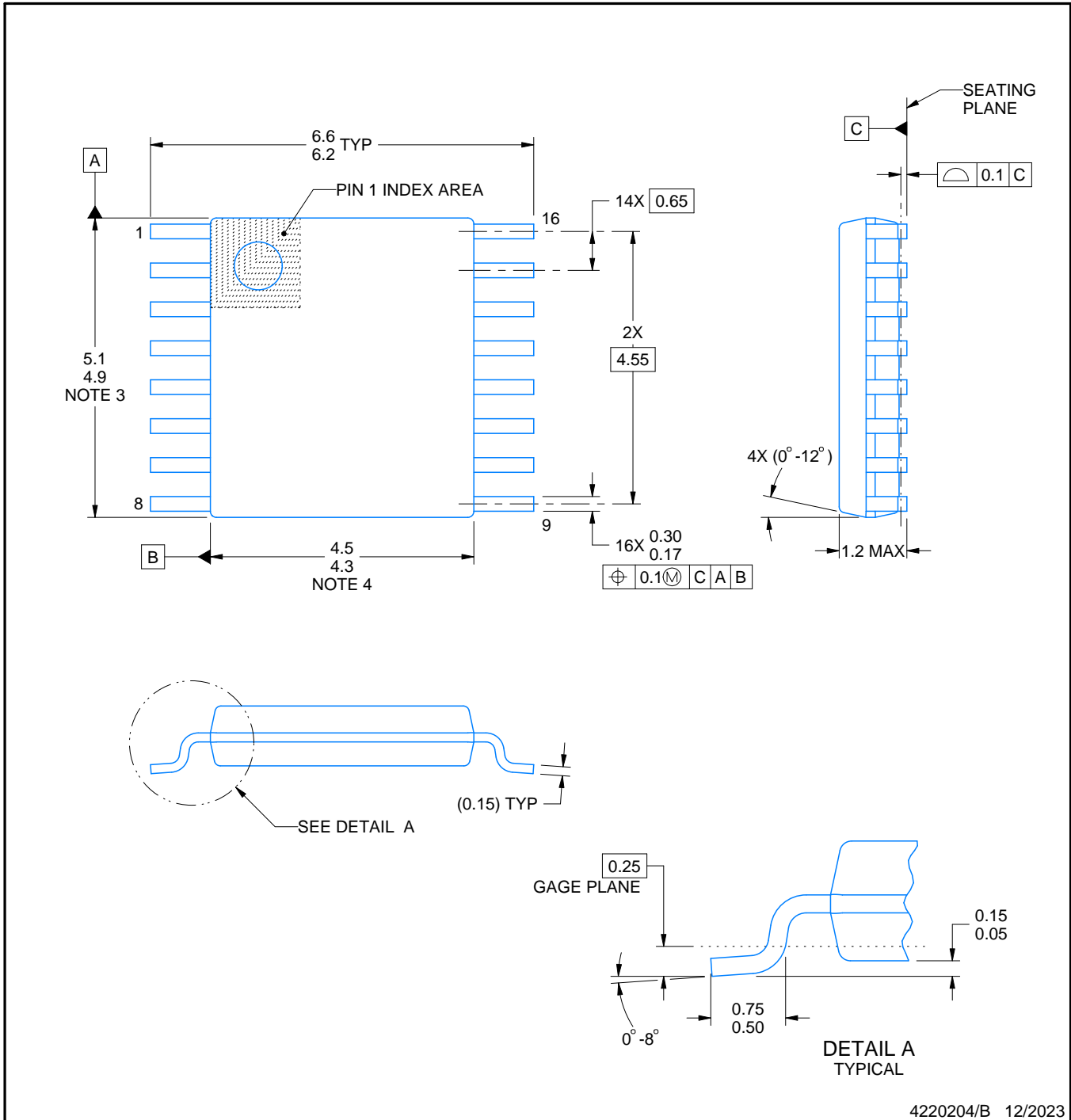
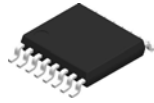

4220204/B 12/2023

NOTES:

1. All linear dimensions are in millimeters. Any dimensions in parenthesis are for reference only. Dimensioning and tolerancing per ASME Y14.5M.
2. This drawing is subject to change without notice.
3. This dimension does not include mold flash, protrusions, or gate burrs. Mold flash, protrusions, or gate burrs shall not exceed 0.15 mm per side.
4. This dimension does not include interlead flash. Interlead flash shall not exceed 0.25 mm per side.
5. Reference JEDEC registration MO-153.

EXAMPLE BOARD LAYOUT

PW0016A

TSSOP - 1.2 mm max height

SMALL OUTLINE PACKAGE

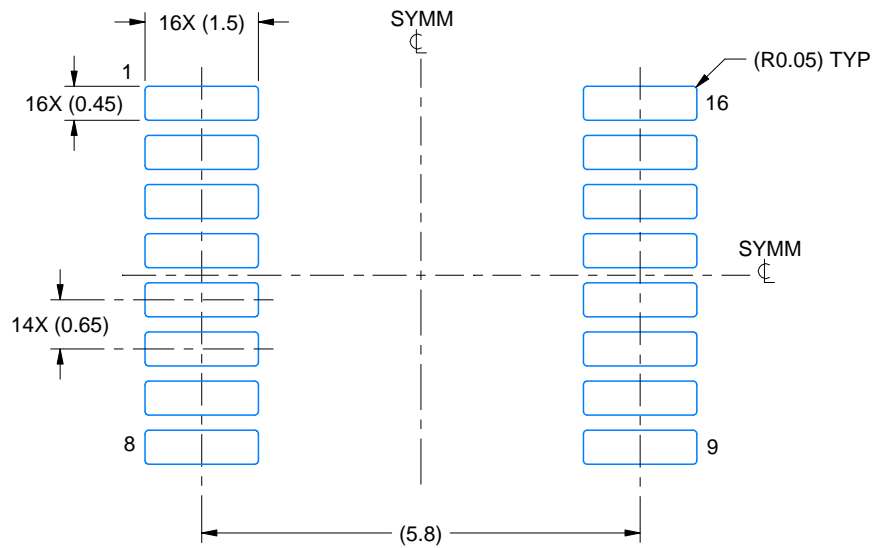

LAND PATTERN EXAMPLE
EXPOSED METAL SHOWN
SCALE: 10X

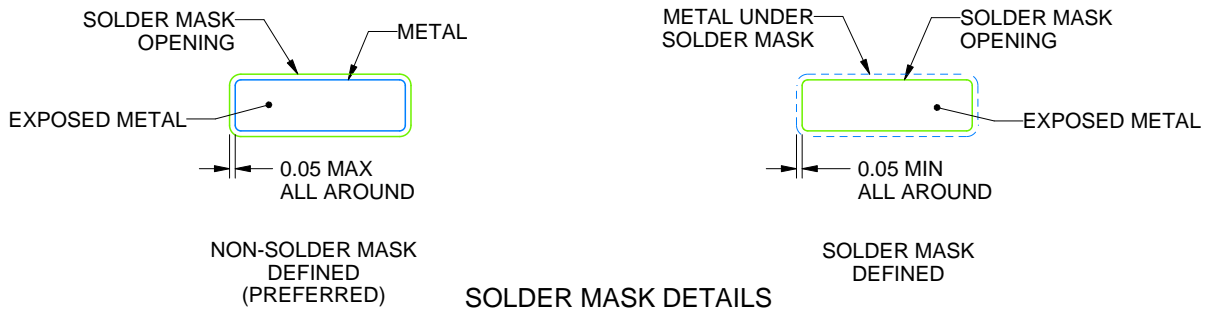

SOLDER MASK DETAILS

4220204/B 12/2023

NOTES: (continued)

- 6. Publication IPC-7351 may have alternate designs.
- 7. Solder mask tolerances between and around signal pads can vary based on board fabrication site.

EXAMPLE STENCIL DESIGN

PW0016A

TSSOP - 1.2 mm max height

SMALL OUTLINE PACKAGE

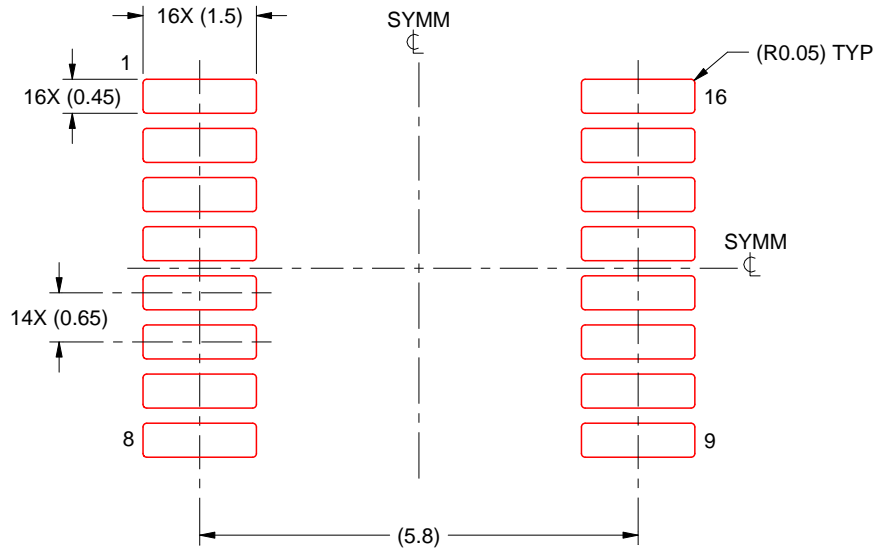

SOLDER PASTE EXAMPLE
BASED ON 0.125 mm THICK STENCIL
SCALE: 10X

4220204/B 12/2023

NOTES: (continued)

8. Laser cutting apertures with trapezoidal walls and rounded corners may offer better paste release. IPC-7525 may have alternate design recommendations.
9. Board assembly site may have different recommendations for stencil design.

IMPORTANT NOTICE AND DISCLAIMER

TI PROVIDES TECHNICAL AND RELIABILITY DATA (INCLUDING DATASHEETS), DESIGN RESOURCES (INCLUDING REFERENCE DESIGNS), APPLICATION OR OTHER DESIGN ADVICE, WEB TOOLS, SAFETY INFORMATION, AND OTHER RESOURCES "AS IS" AND WITH ALL FAULTS, AND DISCLAIMS ALL WARRANTIES, EXPRESS AND IMPLIED, INCLUDING WITHOUT LIMITATION ANY IMPLIED WARRANTIES OF MERCHANTABILITY, FITNESS FOR A PARTICULAR PURPOSE OR NON-INFRINGEMENT OF THIRD PARTY INTELLECTUAL PROPERTY RIGHTS.

These resources are intended for skilled developers designing with TI products. You are solely responsible for (1) selecting the appropriate TI products for your application, (2) designing, validating and testing your application, and (3) ensuring your application meets applicable standards, and any other safety, security, regulatory or other requirements.

These resources are subject to change without notice. TI grants you permission to use these resources only for development of an application that uses the TI products described in the resource. Other reproduction and display of these resources is prohibited. No license is granted to any other TI intellectual property right or to any third party intellectual property right. TI disclaims responsibility for, and you fully indemnify TI and its representatives against any claims, damages, costs, losses, and liabilities arising out of your use of these resources.

TI's products are provided subject to [TI's Terms of Sale](#), [TI's General Quality Guidelines](#), or other applicable terms available either on [ti.com](#) or provided in conjunction with such TI products. TI's provision of these resources does not expand or otherwise alter TI's applicable warranties or warranty disclaimers for TI products. Unless TI explicitly designates a product as custom or customer-specified, TI products are standard, catalog, general purpose devices.

TI objects to and rejects any additional or different terms you may propose.

Copyright © 2026, Texas Instruments Incorporated

Last updated 10/2025