

# SN74LV4053A-Q1 Automotive Triple 2-Channel Analog Multiplexer or Demultiplexer

## 1 Features

- Qualified for automotive applications
- ESD protection exceeds 2000V per MIL-STD-883, method 3015; exceeds 200V using machine model (C = 200pF, R = 0)
- 1.65V to 5.5V  $V_{CC}$  operation
- Supports mixed-mode voltage operation on all ports
- High on-off output-voltage ratio
- Low crosstalk between switches
- Individual switch controls
- Extremely low input current

## 2 Applications

- Automotive:
  - Signal gating
  - Chopping
  - Modulation or demodulation (modem)
  - Signal multiplexing for analog-to-digital and digital-to-analog conversion systems

## 3 Description

This triple 2-channel CMOS analog multiplexer/demultiplexer is designed for 1.65V to 5.5V  $V_{CC}$  operation.

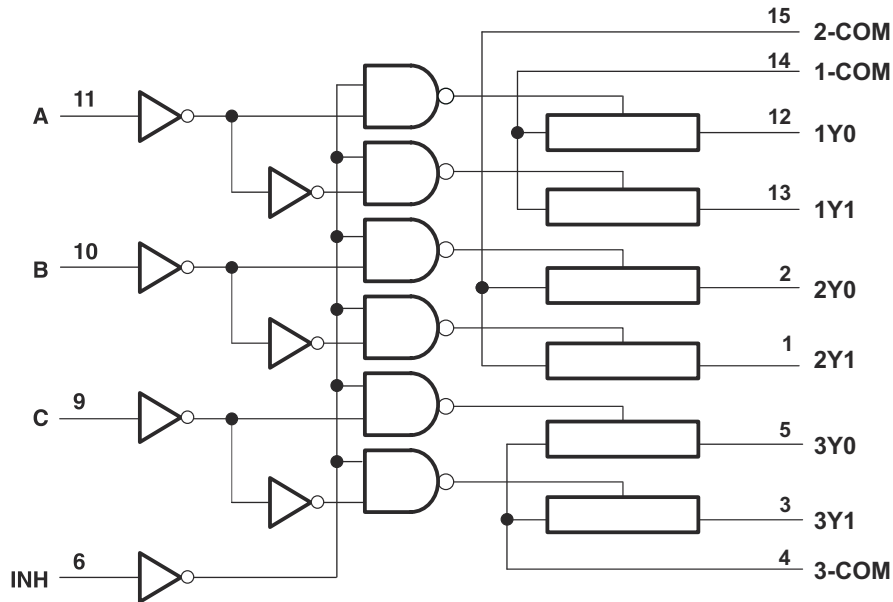
The SN74LV4053A-Q1 handles both analog and digital signals. Each channel permits signals with amplitudes up to 5.5V (peak) to be transmitted in either direction.

Applications include signal gating, chopping, modulation or demodulation (modem), and signal multiplexing for analog-to-digital and digital-to-analog conversion systems.

### Package Information

PART NUMBER	PACKAGE <sup>(1)</sup>	PACKAGE SIZE <sup>(2)</sup>
SN74LV4053A-Q1	PW (TSSOP, 16)	5mm × 6.4mm
	DYY (SOT-23-THIN, 16)	4.2mm x 3.26mm

- (1) For more information, see [Section 11](#).  
 (2) The package size (length × width) is a nominal value and includes pins, where applicable.



Logic Diagram (Positive Logic)

## Table of Contents

<b>1 Features</b> .....	1	7.2 Device Functional Modes.....	14
<b>2 Applications</b> .....	1	<b>8 Application and Implementation</b> .....	15
<b>3 Description</b> .....	1	8.1 Application Information.....	15
<b>4 Pin Configuration and Functions</b> .....	3	8.2 Typical Application.....	15
<b>5 Specifications</b> .....	5	8.3 Design Requirements.....	15
5.1 Absolute Maximum Ratings.....	5	8.4 Detailed Design Procedure.....	15
5.2 ESD Ratings.....	5	8.5 Power Supply Recommendations.....	15
5.3 Thermal Information: SN74LV4053A-Q1.....	5	8.6 Layout.....	15
5.4 Recommended Operating Conditions.....	6	<b>9 Device and Documentation Support</b> .....	17
5.5 Electrical Characteristics.....	6	9.1 Receiving Notification of Documentation Updates....	17
5.6 Timing Characteristics $V_{CC} = 2.5\text{ V} \pm 0.2\text{ V}$ .....	8	9.2 Support Resources.....	17
5.7 Timing Characteristics $V_{CC} = 3.3\text{ V} \pm 0.3\text{ V}$ .....	8	9.3 Trademarks.....	17
5.8 Timing Characteristics $V_{CC} = 5\text{ V} \pm 0.5\text{ V}$ .....	8	9.4 Electrostatic Discharge Caution.....	17
5.9 AC Characteristics.....	9	9.5 Glossary.....	17
<b>6 Parameter Measurement Information</b> .....	10	<b>10 Revision History</b> .....	17
<b>7 Detailed Description</b> .....	14	<b>11 Mechanical, Packaging, and Orderable Information</b> .....	18
7.1 Functional Block Diagram.....	14		

## 4 Pin Configuration and Functions

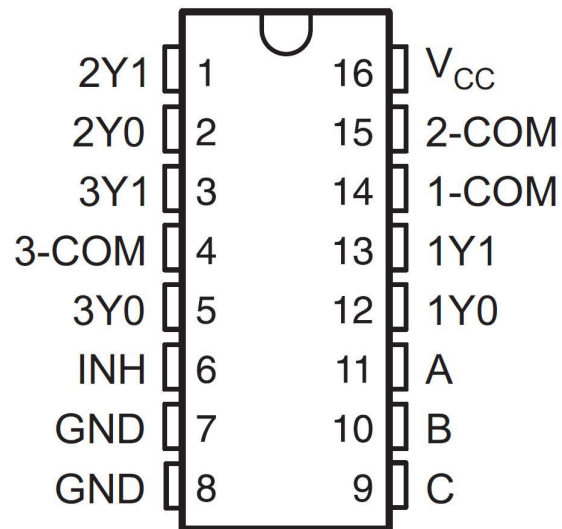


Figure 4-1. D, PW or DYY Package, 16-Pin TSSOP, SOT-23-THIN (Top View)

**Table 4-1. Pin Functions**

PIN		TYPE <sup>(2)</sup>	DESCRIPTION
NAME	NO.		
2Y1	1	I <sup>(1)</sup>	Input to mux 2
2Y0	2	I <sup>(1)</sup>	Input to mux 2
3Y1	3	I <sup>(1)</sup>	Input to mux 3
3-COM	4	O <sup>(1)</sup>	Output of mux 3
3Y0	5	I <sup>(1)</sup>	Input to mux 3
INH	6	I	Enables the outputs of the device. Logic low level with turn the outputs on, high level will turn them off.
GND	7	-	Ground
GND	8	-	Ground
C	9	I	Selector line for outputs (see <a href="#">Section 7.2</a> for specific information)
B	10	I	Selector line for outputs (see <a href="#">Section 7.2</a> for specific information)
A	11	I	Selector line for outputs (see <a href="#">Section 7.2</a> for specific information)
1Y0	12	I <sup>(1)</sup>	Input to mux 1
1Y1	13	I <sup>(1)</sup>	Input to mux 1
1-COM	14	O <sup>(1)</sup>	Output of mux 1
2-COM	15	O <sup>(1)</sup>	Output of mux 2
V <sub>CC</sub>	16	I	Device power input

- (1) These I/O descriptions represent the device when used as a multiplexer, when this device is operated as a demultiplexer pins 1Y0, 1Y1, 2Y0, 2Y1, 3Y0, 3Y1 may be considered outputs (O) and pins 1-COM, 2-COM, and 3-COM may be considered inputs (I).
- (2) I = input, O = output

## 5 Specifications

### 5.1 Absolute Maximum Ratings

over operating free-air temperature range (unless otherwise noted)<sup>(1) (3)</sup>

		MIN	MAX	UNIT
V <sub>CC</sub>	Supply voltage	-0.5	7.0	V
V <sub>I</sub>	Logic input voltage range	-0.5	7.0	V
V <sub>IO</sub>	Switch I/O voltage range <sup>(2) (3)</sup>	-0.5	V <sub>CC</sub> + 0.5	V
I <sub>IK</sub>	Input clamp current	V <sub>I</sub> < 0		mA
I <sub>IOK</sub>	Switch IO diode clamp current	V <sub>IO</sub> < 0 or V <sub>IO</sub> > V <sub>CC</sub>	50	mA
I <sub>T</sub>	Switch continuous current	V <sub>IO</sub> = 0 to V <sub>CC</sub>	±25	mA
	Continuous current through V <sub>CC</sub> or GND		±50	mA
T <sub>stg</sub>	Storage temperature	-65	150	°C

- (1) Operation outside the *Absolute Maximum Ratings* may cause permanent device damage. Absolute maximum ratings do not imply functional operation of the device at these or any other conditions beyond those listed under *Recommended Operating Conditions*. If briefly operating outside the *Recommended Operating Conditions* but within the *Absolute Maximum Ratings*, the device may not sustain damage, but it may not be fully functional. Operating the device in this manner may affect device reliability, functionality, performance, and shorten the device lifetime.
- (2) Pins are diode-clamped to the power-supply rails. Over voltage signals must be voltage and current limited to maximum ratings.
- (3) This value is limited to 5.5 V maximum

### 5.2 ESD Ratings

				VALUE	UNIT
V <sub>(ESD)</sub>	Electrostatic discharge	Human body model (HBM), per AEC Q100-002 <sup>(1)</sup>	All pins	±2000	V
V <sub>(ESD)</sub>	Electrostatic discharge	Charged device model (CDM), per AEC Q100-011	All pins	±500	V

- (1) AEC Q100-002 indicates that HBM stressing shall be in accordance with the ANSI/ESDA/JEDEC JS-001 specification.

### 5.3 Thermal Information: SN74LV4053A-Q1

THERMAL METRIC		SN74LV4053A-Q1	SN74LV4053A-Q1	UNIT
		PW (TSSOP)	DYY (SOT)	
		16 PINS	16 PINS	
R <sub>θJA</sub>	Junction-to-ambient thermal resistance	140.2	199.7	°C/W
R <sub>θJC(top)</sub>	Junction-to-case (top) thermal resistance	72.6	121.2	°C/W
R <sub>θJB</sub>	Junction-to-board thermal resistance	98.7	129.0	°C/W
Ψ <sub>JT</sub>	Junction-to-top characterization parameter	13.4	24.6	°C/W
Ψ <sub>JB</sub>	Junction-to-board characterization parameter	97.3	126.7	°C/W
R <sub>θJC(bot)</sub>	Junction-to-case (bottom) thermal resistance	N/A	N/A	°C/W

## 5.4 Recommended Operating Conditions

over operating free-air temperature range (unless otherwise noted)<sup>(1)</sup>

		MIN	NOM	MAX	UNIT
V <sub>CC</sub>	Supply voltage	1 <sup>(2)</sup>		5.5	V
V <sub>IH</sub>	High-level input voltage, logic control inputs	V <sub>CC</sub> = 1.65		5.5	V
		V <sub>CC</sub> = 2 V	1.5	5.5	
		V <sub>CC</sub> = 2.3 V to 2.7 V	V <sub>CC</sub> × 0.7	5.5	
		V <sub>CC</sub> = 3 V to 3.6 V	V <sub>CC</sub> × 0.7	5.5	
		V <sub>CC</sub> = 4.5 V to 5.5 V	V <sub>CC</sub> × 0.7	5.5	
V <sub>IL</sub>	Low-level input voltage, logic control inputs	V <sub>CC</sub> = 1.65 V	0	0.4	V
		V <sub>CC</sub> = 2	0	0.5	
		V <sub>CC</sub> = 2.3V to 2.7V	0	V <sub>CC</sub> × 0.3	
		V <sub>CC</sub> = 3 V to 3.6 V	0	V <sub>CC</sub> × 0.3	
		V <sub>CC</sub> = 4.5 V to 5.5 V	0	V <sub>CC</sub> × 0.3	
V <sub>I</sub>	Logic control input voltage	0		5.5	V
V <sub>IO</sub>	Switch input or output voltage	0		V <sub>CC</sub>	V
Δt/ΔV	Logic input transition rise or fall rate	V <sub>CC</sub> = 1.0 V to 2.0 V		500	ns/V
		V <sub>CC</sub> = 2.0 V to 2.7 V		200	
		V <sub>CC</sub> = 3 V to 3.6 V		100	
		V <sub>CC</sub> = 4.5 V to 5.5 V		20	
T <sub>A</sub>	Ambient temperature	−40		125	°C

(1) All unused inputs of the device must be held at V<sub>CC</sub> or GND to ensure proper device operation. Refer to TI application report *Implications of Slow or Floating CMOS Inputs*, SCBA004.

(2) When using a V<sub>CC</sub> of ≤1.2 V, it is recommended to use these devices only for transmitting digital signals. When supply voltage is near 1.2 V the analog switch ON resistance becomes very non-linear

## 5.5 Electrical Characteristics

over recommended operating free-air temperature range (unless otherwise noted)

PARAMETER	Condition	T <sub>A</sub>	V <sub>CC</sub>	MIN	TYP	MAX	UNIT
r <sub>ON</sub>	ON-state switch resistance	I <sub>T</sub> = 2 mA, V <sub>I</sub> = V <sub>CC</sub> or GND, V <sub>INH</sub> = V <sub>IL</sub>	1.65 V	25°C	60	150	Ω
				−40°C to 85°C		225	
				−40°C to 125°C		225	
			2.3 V	25°C	38	180	
				−40°C to 85°C		225	
				−40°C to 125°C		225	
			3 V	25°C	30	150	
				−40°C to 85°C		190	
				−40°C to 125°C		190	
			4.5 V	25°C	22	75	
				−40°C to 85°C		100	
				−40°C to 125°C		100	

## 5.5 Electrical Characteristics (continued)

over recommended operating free-air temperature range (unless otherwise noted)

PARAMETER	Condition	T <sub>A</sub>	V <sub>CC</sub>	MIN	TYP	MAX	UNIT
r <sub>ON(p)</sub>	Peak ON-state resistance  I <sub>T</sub> = 2 mA, V <sub>I</sub> = GND to V <sub>CC</sub> , V <sub>INH</sub> = V <sub>IL</sub>	25°C	1.65 V		220	600	Ω
		-40°C to 85°C				700	
		-40°C to 125°C				700	
		25°C	2.3 V		113	500	
		-40°C to 85°C				600	
		-40°C to 125°C				600	
		25°C	3 V		54	180	
		-40°C to 85°C				225	
		-40°C to 125°C				225	
		25°C	4.5 V		31	100	
		-40°C to 85°C				125	
		-40°C to 125°C				125	
Δr <sub>ON</sub>	Difference in ON-state resistance between switches  I <sub>T</sub> = 2 mA, V <sub>I</sub> = GND to V <sub>CC</sub> , V <sub>INH</sub> = V <sub>IL</sub>	25°C	1.65 V		3	40	Ω
		-40°C to 85°C				40	
		-40°C to 125°C				40	
		25°C	2.3 V		2.1	30	
		-40°C to 85°C				40	
		-40°C to 125°C				40	
		25°C	3 V		1.4	20	
		-40°C to 85°C				30	
		-40°C to 125°C				30	
		25°C	4.5 V		1.3	15	
		-40°C to 85°C				20	
		-40°C to 125°C				20	
I <sub>IH</sub> I <sub>IL</sub>	Control input current  V <sub>I</sub> = 5.5 V or GND	25°C	0 to 5.5 V	-0.1		0.1	μA
		-40°C to 85°C		-1		1	
		-40°C to 125°C		-2		2	
I <sub>S(off)</sub>	OFF-state switch leakage current  V <sub>I</sub> = V <sub>CC</sub> and V <sub>O</sub> = GND, or V <sub>I</sub> = GND and V <sub>O</sub> = V <sub>CC</sub> , V <sub>INH</sub> = V <sub>IH</sub>	25°C	5.5 V	-0.1		0.1	μA
		-40°C to 85°C		-1		1	
		-40°C to 125°C		-2		2	
I <sub>S(on)</sub>	ON-state switch leakage current  V <sub>I</sub> = V <sub>CC</sub> or GND, V <sub>INH</sub> = V <sub>IL</sub>	25°C	5.5 V	-0.1		0.1	μA
		-40°C to 85°C		-1		1	
		-40°C to 125°C		-2		2	
I <sub>CC</sub>	Supply current  V <sub>I</sub> = V <sub>CC</sub> or GND V <sub>INH</sub> = 0 V	25°C	5.5 V		0.01		μA
		-40°C to 85°C				20	
		-40°C to 125°C				40	
C <sub>IC</sub>	Control input capacitance	f = 10 MHz	25°C	3.3 V		2	pF
C <sub>IS</sub>	Common terminal capacitance	f = 10 MHz	25°C	3.3 V		8.2	pF
C <sub>OS</sub>	Switch terminal capacitance	f = 10 MHz	25°C	3.3 V		5.7	pF
C <sub>F</sub>	Feedthrough capacitance	f = 10 MHz	25°C	3.3 V		0.5	pF

## 5.5 Electrical Characteristics (continued)

over recommended operating free-air temperature range (unless otherwise noted)

PARAMETER		Condition	T <sub>A</sub>	V <sub>CC</sub>	MIN	TYP	MAX	UNIT
C <sub>PD</sub>	Power dissipation capacitance	C <sub>L</sub> = 50 pF, f = 10 MHz	25°C	3.3 V		5.3		pF

## 5.6 Timing Characteristics V<sub>CC</sub> = 2.5 V ± 0.2 V

PARAMETER		FROM (INPUT)	TO (OUTPUT)	CONDITIONS	T <sub>A</sub>	MIN	TYP	MAX	UNIT
t <sub>PLH</sub> t <sub>PHL</sub>	Propagation delay time	COM or Yn	Yn or COM	C <sub>L</sub> = 15 pF	25°C		1.9	10	ns
					-40°C to 85°C			16	
					-40°C to 125°C			18	
t <sub>PZH</sub> t <sub>PZL</sub>	Enable delay time	INH	COM or Yn	C <sub>L</sub> = 15 pF	25°C		6.6	18	ns
					-40°C to 85°C			23	
					-40°C to 125°C			25	
t <sub>PHZ</sub> t <sub>PLZ</sub>	Disable delay time	INH	COM or Yn	C <sub>L</sub> = 15 pF	25°C		7.4	18	ns
					-40°C to 85°C			23	
					-40°C to 125°C			25	
t <sub>PLH</sub> t <sub>PHL</sub>	Propagation delay time	COM or Yn	Yn or COM	C <sub>L</sub> = 50 pF	25°C		3.8	12	ns
					-40°C to 85°C			18	
					-40°C to 125°C			20	
t <sub>PZH</sub> t <sub>PZL</sub>	Enable delay time	INH	COM or Yn	C <sub>L</sub> = 50 pF	25°C		7.8	28	ns
					-40°C to 85°C			35	
					-40°C to 125°C			35	
t <sub>PHZ</sub> t <sub>PLZ</sub>	Disable delay time	INH	COM or Yn	C <sub>L</sub> = 50 pF	25°C		11.5	28	ns
					-40°C to 85°C			35	
					-40°C to 125°C			35	

## 5.7 Timing Characteristics V<sub>CC</sub> = 3.3 V ± 0.3 V

PARAMETER		FROM (INPUT)	TO (OUTPUT)	CONDITIONS	T <sub>A</sub>	MIN	TYP	MAX	UNIT
t <sub>PLH</sub> t <sub>PHL</sub>	Propagation delay time	COM or Yn	Yn or COM	C <sub>L</sub> = 50 pF	25°C		2.5	9	ns
					-40°C to 85°C			12	
					-40°C to 125°C			14	
t <sub>PZH</sub> t <sub>PZL</sub>	Enable delay time	INH	COM or Yn	C <sub>L</sub> = 50 pF	25°C		5.5	20	ns
					-40°C to 85°C			25	
					-40°C to 125°C			25	
t <sub>PHZ</sub> t <sub>PLZ</sub>	Disable delay time	INH	COM or Yn	C <sub>L</sub> = 50 pF	25°C		8.8	20	ns
					-40°C to 85°C			25	
					-40°C to 125°C			25	

## 5.8 Timing Characteristics V<sub>CC</sub> = 5 V ± 0.5 V

PARAMETER		FROM (INPUT)	TO (OUTPUT)	CONDITIONS	T <sub>A</sub>	MIN	TYP	MAX	UNIT
t <sub>PLH</sub> t <sub>PHL</sub>	Propagation delay time	COM or Yn	Yn or COM	C <sub>L</sub> = 50 pF	25°C		1.5	6	ns
					-40°C to 85°C			8	
					-40°C to 125°C			10	



**5.8 Timing Characteristics  $V_{CC} = 5\text{ V} \pm 0.5\text{ V}$  (continued)**

PARAMETER		FROM (INPUT)	TO (OUTPUT)	CONDITIONS	$T_A$	MIN	TYP	MAX	UNIT
$t_{PZH}$ $t_{PZL}$	Enable delay time	INH	COM or Yn	$C_L = 50\text{ pF}$	25°C		4	14	ns
					-40°C to 85°C			18	
					-40°C to 125°C			18	
$t_{PHZ}$ $t_{PLZ}$	Disable delay time	INH	COM or Yn	$C_L = 50\text{ pF}$	25°C		6.2	14	ns
					-40°C to 85°C			18	
					-40°C to 125°C			18	

**5.9 AC Characteristics**

PARAMETER	FROM (INPUT)	TO (OUTPUT)	Device	CONDITIONS	MIN	TYP	MAX	UNIT
Frequency response (switch on)	COM or Yn	Yn or COM	SN74LV4053	$C_L = 50\text{ pF}$ , $R_L = 600\ \Omega$ , $F_{in} = 1\text{ MHz}$ (sine wave),	$V_{CC} = 2.3\text{ V}$		30	MHz
					$V_{CC} = 3\text{ V}$		35	
					$V_{CC} = 4.5\text{ V}$		50	
Feedthrough attenuation (switch off)	COM or Yn	Yn or COM	ALL	$C_L = 50\text{ pF}$ , $R_L = 600\ \Omega$ , $F_{in} = 1\text{ MHz}$ (sine wave)	$V_{CC} = 2.3\text{ V}$		-45	dB
					$V_{CC} = 3\text{ V}$		-45	
					$V_{CC} = 4.5\text{ V}$		-45	
Crosstalk (between any switches)	COM or Yn	Yn or COM	ALL	$C_L = 50\text{ pF}$ , $R_L = 600\ \Omega$ , $F_{in} = 1\text{ MHz}$ (sine wave)	$V_{CC} = 2.3\text{ V}$		20	mV
					$V_{CC} = 3\text{ V}$		35	
					$V_{CC} = 4.5\text{ V}$		60	
Sine-wave distortion	COM or Yn	Yn or COM	ALL	$C_L = 50\text{ pF}$ , $R_L = 10\text{ k}\Omega$ , $F_{in} = 1\text{ kHz}$ (sine wave)	$V_I = 2\text{ V}_{p-p}$ $V_{CC} = 2.3\text{ V}$		0.1	%
					$V_I = 2.5\text{ V}_{p-p}$ $V_{CC} = 3\text{ V}$		0.1	
					$V_I = 4\text{ V}_{p-p}$ $V_{CC} = 4.5\text{ V}$		0.1	

## 6 Parameter Measurement Information

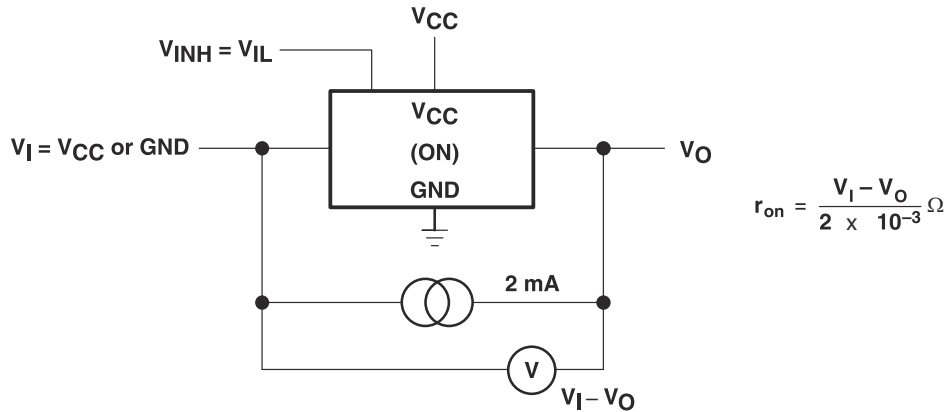


Figure 6-1. On-State Resistance Test Circuit

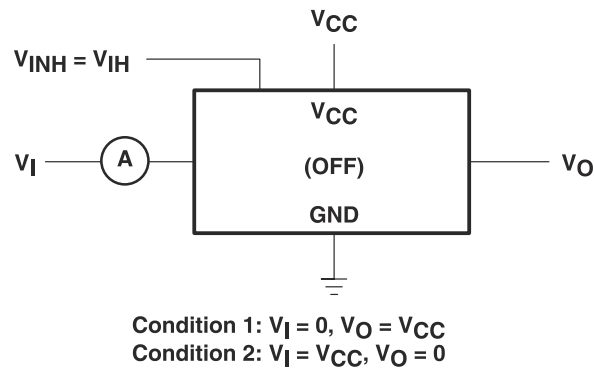


Figure 6-2. Off-State Switch Leakage-Current Test Circuit

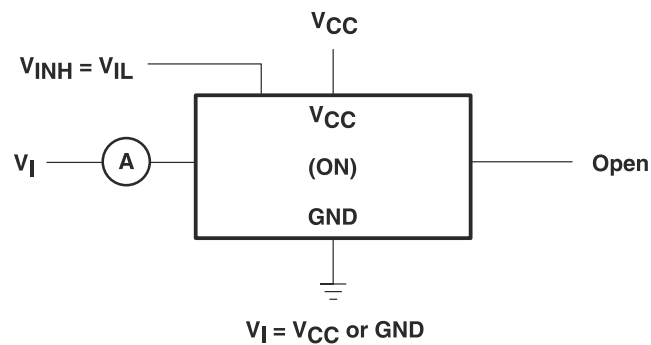
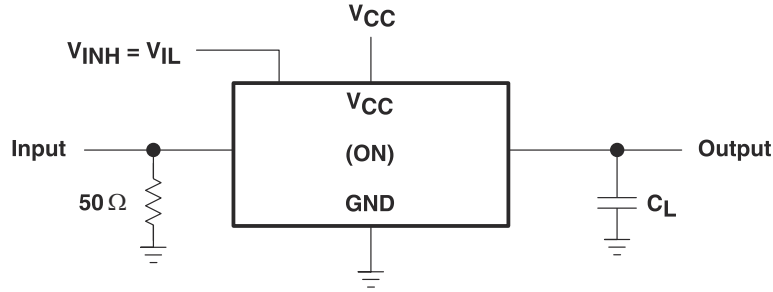
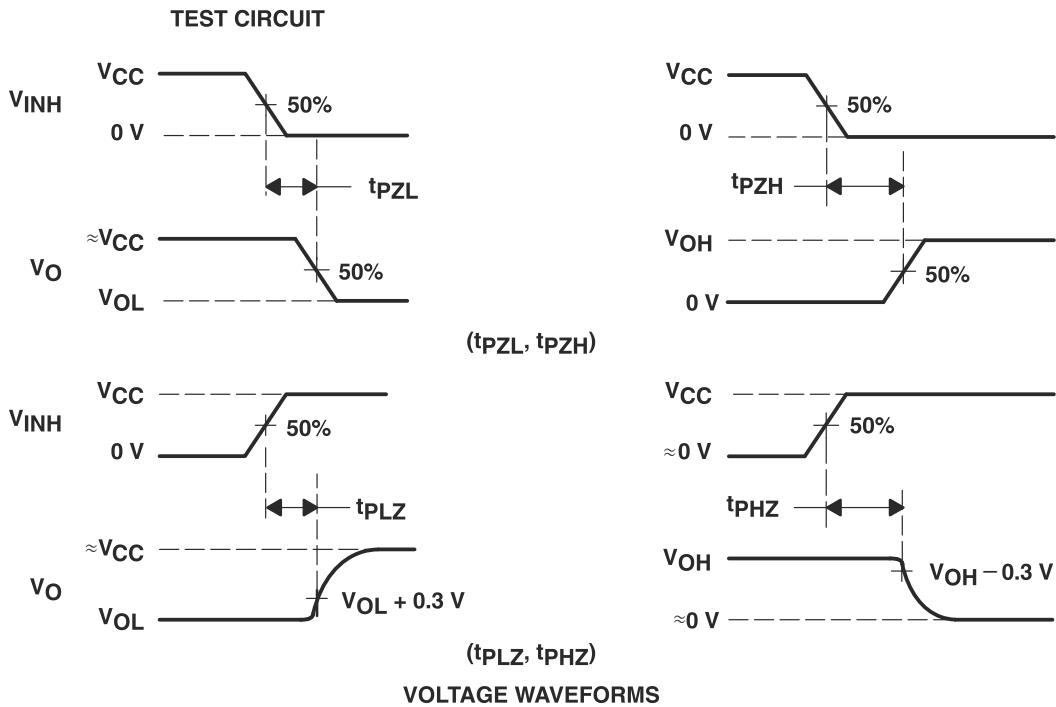
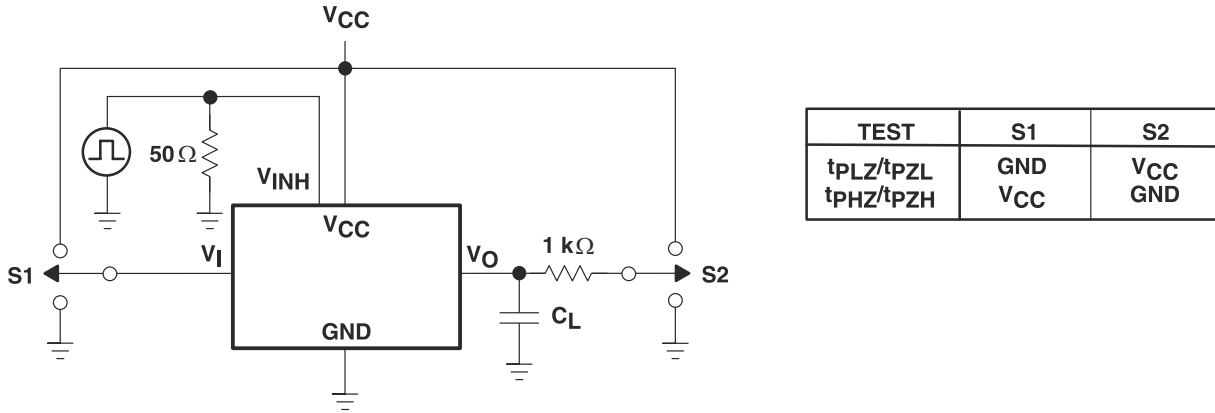


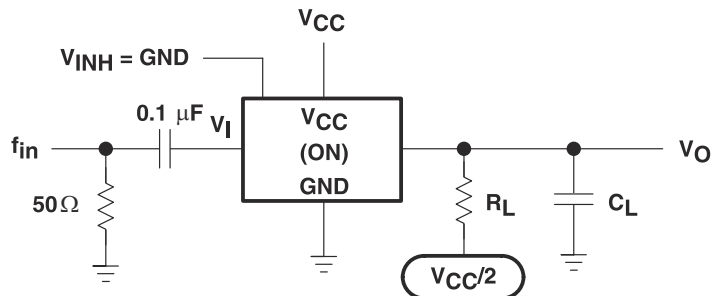
Figure 6-3. On-State Switch Leakage-Current Test Circuit



**Figure 6-4. Propagation Delay Time, Signal Input to Signal Output**

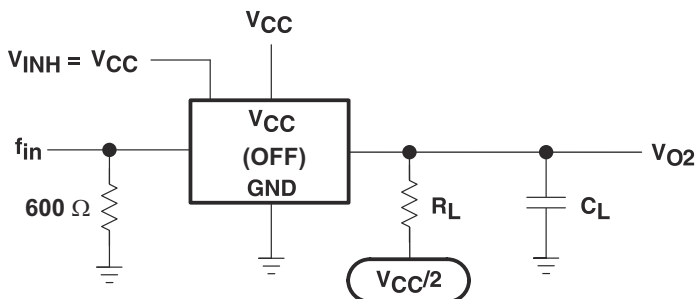
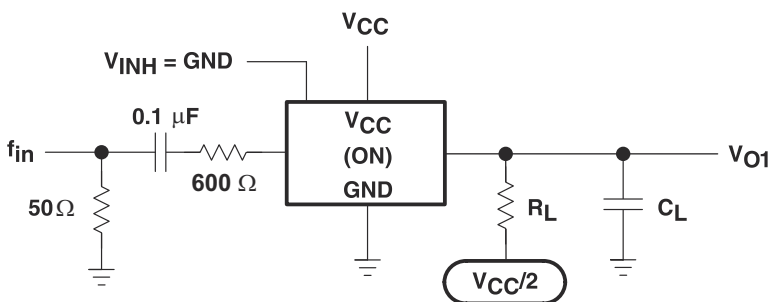


**Figure 6-5. Switching Time ( $t_{PZL}$ ,  $t_{PLZ}$ ,  $t_{PZH}$ ,  $t_{PHZ}$ ), Control to Signal Output**

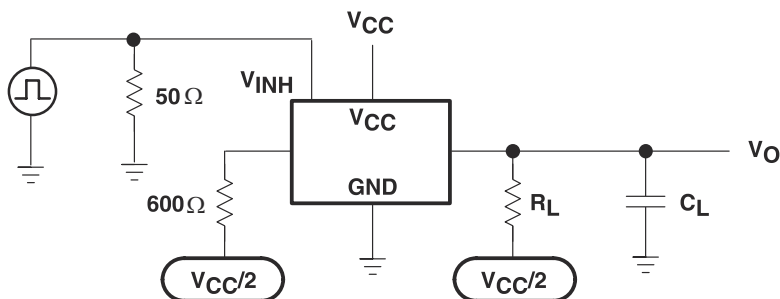


NOTE A:  $f_{in}$  is a sine wave.

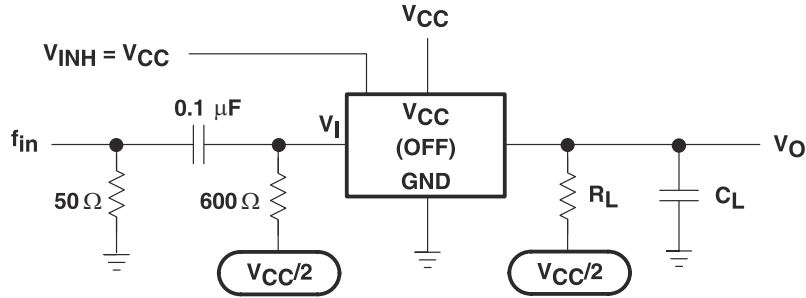
**Figure 6-6. Frequency Response (Switch On)**



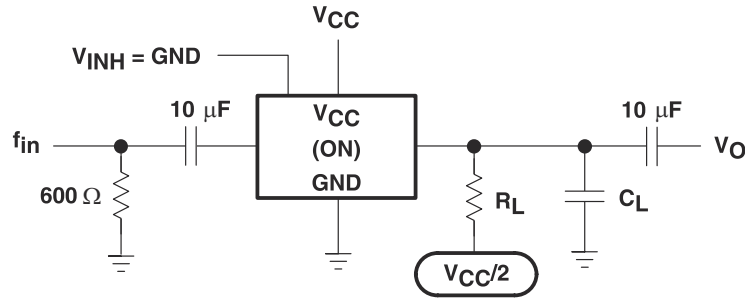
**Figure 6-7. Crosstalk Between Any Two Switches**



**Figure 6-8. Crosstalk Between Control Input and Switch Output**



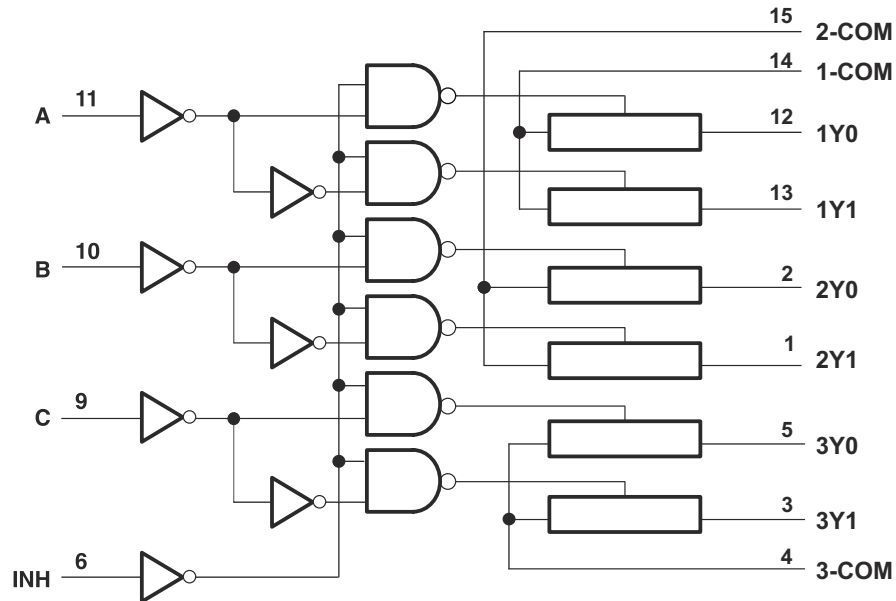
**Figure 6-9. Feedthrough Attenuation (Switch Off)**



**Figure 6-10. Sine-Wave Distortion**

## 7 Detailed Description

### 7.1 Functional Block Diagram



### 7.2 Device Functional Modes

Function Table

INPUTS				ON CHANNEL
INH	C	B	A	
L	L	L	L	1Y0, 2Y0, 3Y0
L	L	L	H	1Y1, 2Y0, 3Y0
L	L	H	L	1Y0, 2Y1, 3Y0
L	L	H	H	1Y1, 2Y1, 3Y0
L	H	L	L	1Y0, 2Y0, 3Y1
L	H	L	H	1Y1, 2Y0, 3Y1
L	H	H	L	1Y0, 2Y1, 3Y1
L	H	H	H	1Y1, 2Y1, 3Y1
H	X	X	X	None

## 8 Application and Implementation

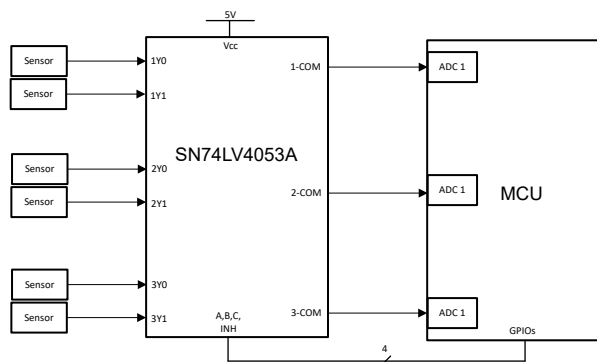
### Note

Information in the following applications sections is not part of the TI component specification, and TI does not warrant its accuracy or completeness. TI's customers are responsible for determining suitability of components for their purposes, as well as validating and testing their design implementation to confirm system functionality.

### 8.1 Application Information

A multiplexer is used in applications where multiple signals share a resource. In the following example, several different sensors are connected to the analog-to-digital converter (ADC) of a microcontroller (MCU).

### 8.2 Typical Application



**Figure 8-1. Typical Application Schematic**

### 8.3 Design Requirements

Processing 8 different analog signals would normally require 8 separate ADCs, but the previous figure shows how to achieve this using only 2 ADCs and 3 GPIOs (general purpose input/outputs).

### 8.4 Detailed Design Procedure

To design with the SN74LV4053A-Q1, a stable input voltage between 2V (see *Recommended Operating Conditions* for details) and 5.5V must be available. The characteristics of the signal that is being multiplexed so that no important information is lost due to timing or voltage level incompatibility with this device is another important design consideration.

### 8.5 Power Supply Recommendations

Most systems have a common 3.3V or 5V rail that may be used to supply the  $V_{CC}$  pin of this device. If this is not available, then a Switch-Mode-Power-Supply (SMPS) or a Linear Dropout Regulator (LDO) may be used to supply this device from a higher voltage rail.

### 8.6 Layout

#### 8.6.1 Layout Guidelines

In general, it is best to keep signal lines as short and as straight as possible. Incorporation of microstrip or stripline techniques is also recommended when signal lines are greater than 1 inch in length. These traces must be designed with a characteristic impedance of either 50Ω or 75Ω, as required by the application. Be careful when placing this device too close to high voltage switching components, as they may cause interference.

### 8.6.2 Layout Example

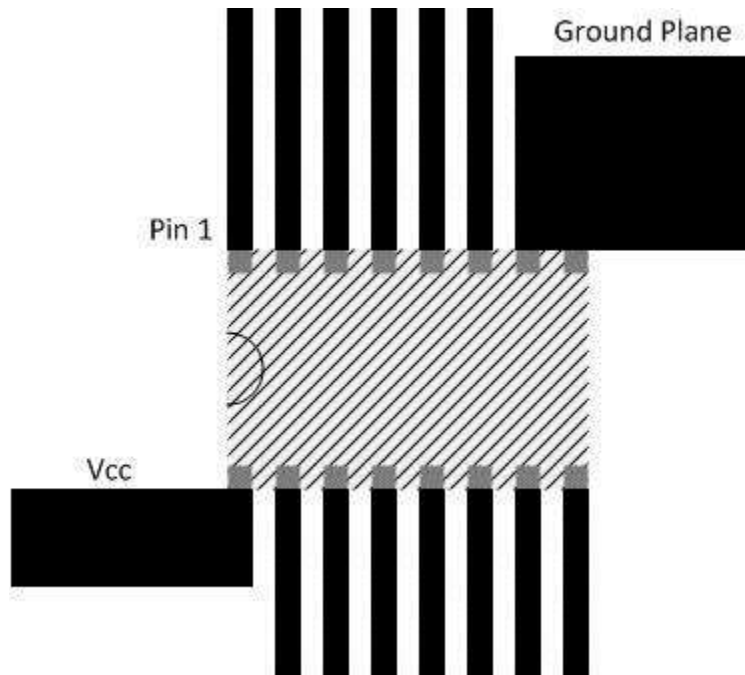


Figure 8-2. Layout Example Schematic



## 9 Device and Documentation Support

TI offers an extensive line of development tools. Tools and software to evaluate the performance of the device, generate code, and develop solutions are listed below.

### 9.1 Receiving Notification of Documentation Updates

To receive notification of documentation updates, navigate to the device product folder on [ti.com](http://ti.com). Click on *Notifications* to register and receive a weekly digest of any product information that has changed. For change details, review the revision history included in any revised document.

### 9.2 Support Resources

TI E2E™ [support forums](#) are an engineer's go-to source for fast, verified answers and design help — straight from the experts. Search existing answers or ask your own question to get the quick design help you need.

Linked content is provided "AS IS" by the respective contributors. They do not constitute TI specifications and do not necessarily reflect TI's views; see TI's [Terms of Use](#).

### 9.3 Trademarks

TI E2E™ is a trademark of Texas Instruments.  
All trademarks are the property of their respective owners.

### 9.4 Electrostatic Discharge Caution



This integrated circuit can be damaged by ESD. Texas Instruments recommends that all integrated circuits be handled with appropriate precautions. Failure to observe proper handling and installation procedures can cause damage.

ESD damage can range from subtle performance degradation to complete device failure. Precision integrated circuits may be more susceptible to damage because very small parametric changes could cause the device not to meet its published specifications.

### 9.5 Glossary

[TI Glossary](#) This glossary lists and explains terms, acronyms, and definitions.

## 10 Revision History

NOTE: Page numbers for previous revisions may differ from page numbers in the current version.

<b>Changes from Revision E (September 2024) to Revision F (October 2024)</b>	<b>Page</b>
• Added 50mA to the Switch IO diode clamp current.....	5
• Added typical spec for I <sub>cc</sub> at 25°C.....	6

---

<b>Changes from Revision D (June 2024) to Revision E (September 2024)</b>	<b>Page</b>
• Added DYY package and size.....	1
• Added DYY package.....	3

---

<b>Changes from Revision C (June 2011) to Revision D (June 2024)</b>	<b>Page</b>
• Changed the numbering format for tables, figures, and cross-references throughout the document.....	1
• Added new VIH and VIL Specifications at 1.65V V <sub>cc</sub> .....	6
• Added Ron, Ron Peak, and Delta Ron Specifications at 1.65V V <sub>cc</sub> .....	6

---

## 11 Mechanical, Packaging, and Orderable Information

The following pages include mechanical, packaging, and orderable information. This information is the most current data available for the designated devices. This data is subject to change without notice and revision of this document. For browser-based versions of this data sheet, refer to the left-hand navigation.

**PACKAGING INFORMATION**

Orderable Device	Status (1)	Package Type	Package Drawing	Pins	Package Qty	Eco Plan (2)	Lead finish/ Ball material (6)	MSL Peak Temp (3)	Op Temp (°C)	Device Marking (4/5)	Samples
CLV4053ATPWRG4Q1	OBSOLETE	TSSOP	PW	16		TBD	Call TI	Call TI	-40 to 105	L4053AQ	
SN74LV4053AQDYRQ1	ACTIVE	SOT-23-THIN	DYY	16	3000	RoHS & Green	NIPDAU	Level-1-260C-UNLIM	-40 to 125	LV4053Q	Samples
SN74LV4053AQPWRQ1	ACTIVE	TSSOP	PW	16	2000	RoHS & Green	NIPDAU	Level-1-260C-UNLIM	-40 to 125	4053AQ1	Samples
SN74LV4053ATDRQ1	NRND	SOIC	D	16	2500	RoHS & Green	NIPDAU	Level-1-260C-UNLIM	-40 to 105	L4053AQ	
SN74LV4053ATPWRQ1	OBSOLETE	TSSOP	PW	16		TBD	Call TI	Call TI	-40 to 105	L4053AQ	

(1) The marketing status values are defined as follows:

**ACTIVE:** Product device recommended for new designs.

**LIFEBUY:** TI has announced that the device will be discontinued, and a lifetime-buy period is in effect.

**NRND:** Not recommended for new designs. Device is in production to support existing customers, but TI does not recommend using this part in a new design.

**PREVIEW:** Device has been announced but is not in production. Samples may or may not be available.

**OBSOLETE:** TI has discontinued the production of the device.

(2) **RoHS:** TI defines "RoHS" to mean semiconductor products that are compliant with the current EU RoHS requirements for all 10 RoHS substances, including the requirement that RoHS substance do not exceed 0.1% by weight in homogeneous materials. Where designed to be soldered at high temperatures, "RoHS" products are suitable for use in specified lead-free processes. TI may reference these types of products as "Pb-Free".

**RoHS Exempt:** TI defines "RoHS Exempt" to mean products that contain lead but are compliant with EU RoHS pursuant to a specific EU RoHS exemption.

**Green:** TI defines "Green" to mean the content of Chlorine (Cl) and Bromine (Br) based flame retardants meet JS709B low halogen requirements of <=1000ppm threshold. Antimony trioxide based flame retardants must also meet the <=1000ppm threshold requirement.

(3) MSL, Peak Temp. - The Moisture Sensitivity Level rating according to the JEDEC industry standard classifications, and peak solder temperature.

(4) There may be additional marking, which relates to the logo, the lot trace code information, or the environmental category on the device.

(5) Multiple Device Markings will be inside parentheses. Only one Device Marking contained in parentheses and separated by a "~" will appear on a device. If a line is indented then it is a continuation of the previous line and the two combined represent the entire Device Marking for that device.

(6) Lead finish/Ball material - Orderable Devices may have multiple material finish options. Finish options are separated by a vertical ruled line. Lead finish/Ball material values may wrap to two lines if the finish value exceeds the maximum column width.

**Important Information and Disclaimer:** The information provided on this page represents TI's knowledge and belief as of the date that it is provided. TI bases its knowledge and belief on information provided by third parties, and makes no representation or warranty as to the accuracy of such information. Efforts are underway to better integrate information from third parties. TI has taken and

continues to take reasonable steps to provide representative and accurate information but may not have conducted destructive testing or chemical analysis on incoming materials and chemicals. TI and TI suppliers consider certain information to be proprietary, and thus CAS numbers and other limited information may not be available for release.

In no event shall TI's liability arising out of such information exceed the total purchase price of the TI part(s) at issue in this document sold by TI to Customer on an annual basis.

**OTHER QUALIFIED VERSIONS OF SN74LV4053A-Q1 :**

- Catalog : [SN74LV4053A](#)
- Enhanced Product : [SN74LV4053A-EP](#)

NOTE: Qualified Version Definitions:

- Catalog - TI's standard catalog product
- Enhanced Product - Supports Defense, Aerospace and Medical Applications

**TAPE AND REEL INFORMATION**

**QUADRANT ASSIGNMENTS FOR PIN 1 ORIENTATION IN TAPE**


\*All dimensions are nominal

Device	Package Type	Package Drawing	Pins	SPQ	Reel Diameter (mm)	Reel Width W1 (mm)	A0 (mm)	B0 (mm)	K0 (mm)	P1 (mm)	W (mm)	Pin1 Quadrant
SN74LV4053AQDYRQ1	SOT-23-THIN	DYY	16	3000	330.0	12.4	4.8	3.6	1.6	8.0	12.0	Q3

**TAPE AND REEL BOX DIMENSIONS**




\*All dimensions are nominal

Device	Package Type	Package Drawing	Pins	SPQ	Length (mm)	Width (mm)	Height (mm)
SN74LV4053AQDYRQ1	SOT-23-THIN	DYY	16	3000	336.6	336.6	31.8

D (R-PDSO-G16)

PLASTIC SMALL OUTLINE



- NOTES:
- A. All linear dimensions are in inches (millimeters).
  - B. This drawing is subject to change without notice.
  -  Body length does not include mold flash, protrusions, or gate burrs. Mold flash, protrusions, or gate burrs shall not exceed 0.006 (0,15) each side.
  -  Body width does not include interlead flash. Interlead flash shall not exceed 0.017 (0,43) each side.
  - E. Reference JEDEC MS-012 variation AC.



4220204/A 02/2017

NOTES:

1. All linear dimensions are in millimeters. Any dimensions in parenthesis are for reference only. Dimensioning and tolerancing per ASME Y14.5M.
2. This drawing is subject to change without notice.
3. This dimension does not include mold flash, protrusions, or gate burrs. Mold flash, protrusions, or gate burrs shall not exceed 0.15 mm per side.
4. This dimension does not include interlead flash. Interlead flash shall not exceed 0.25 mm per side.
5. Reference JEDEC registration MO-153.



# EXAMPLE BOARD LAYOUT

PW0016A

TSSOP - 1.2 mm max height

SMALL OUTLINE PACKAGE



LAND PATTERN EXAMPLE  
EXPOSED METAL SHOWN  
SCALE: 10X



SOLDER MASK DETAILS

4220204/A 02/2017

NOTES: (continued)

- 6. Publication IPC-7351 may have alternate designs.
- 7. Solder mask tolerances between and around signal pads can vary based on board fabrication site.

# EXAMPLE STENCIL DESIGN

PW0016A

TSSOP - 1.2 mm max height

SMALL OUTLINE PACKAGE

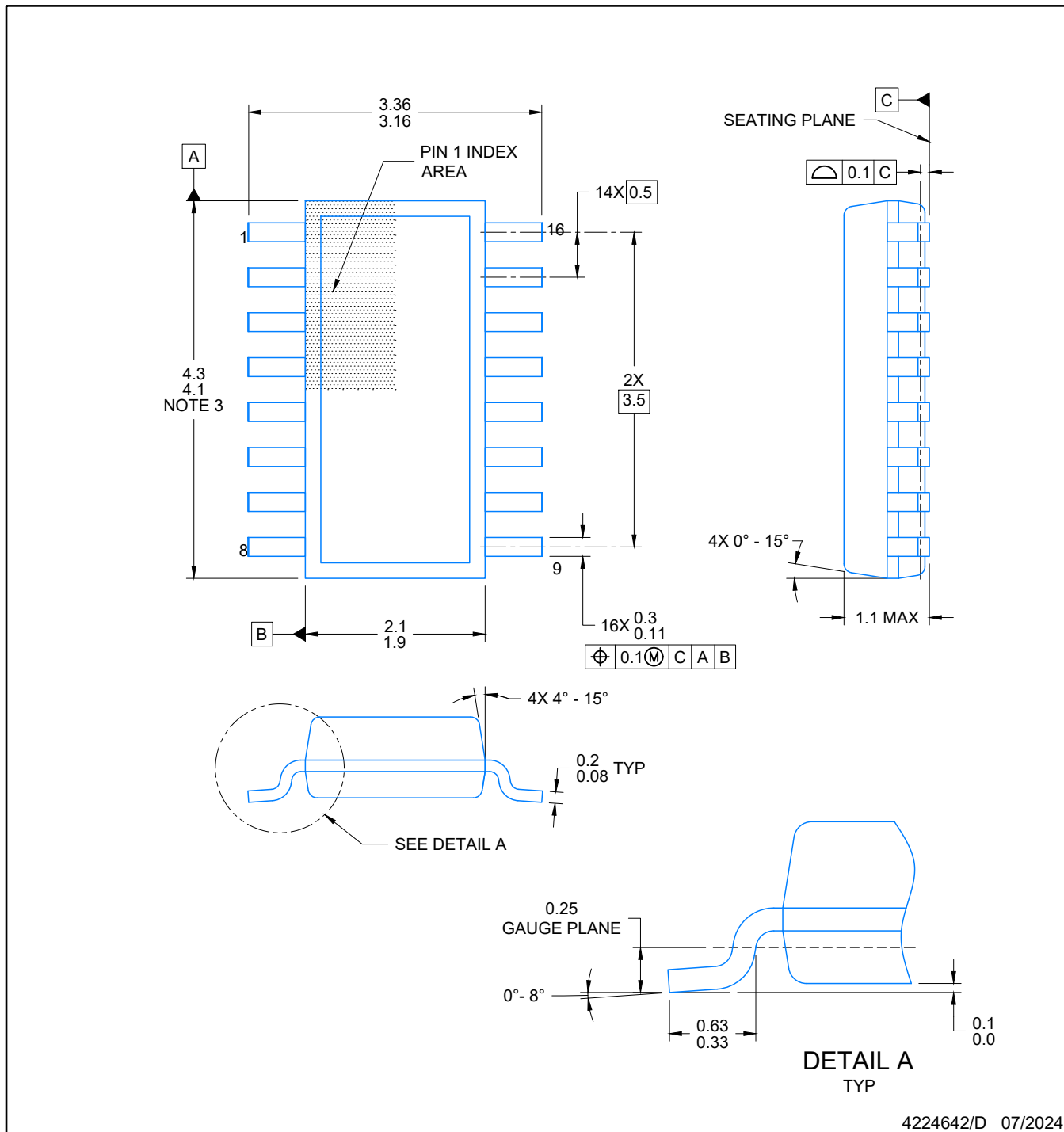


SOLDER PASTE EXAMPLE  
BASED ON 0.125 mm THICK STENCIL  
SCALE: 10X

4220204/A 02/2017

NOTES: (continued)

8. Laser cutting apertures with trapezoidal walls and rounded corners may offer better paste release. IPC-7525 may have alternate design recommendations.
9. Board assembly site may have different recommendations for stencil design.



4224642/D 07/2024

**NOTES:**

1. All linear dimensions are in millimeters. Any dimensions in parenthesis are for reference only. Dimensioning and tolerancing per ASME Y14.5M.
2. This drawing is subject to change without notice.
3. This dimension does not include mold flash, protrusions, or gate burrs. Mold flash, protrusions, or gate burrs shall not exceed 0.15 per side.
4. This dimension does not include interlead flash. Interlead flash shall not exceed 0.50 per side.
5. Reference JEDEC Registration MO-345, Variation AA



LAND PATTERN EXAMPLE  
EXPOSED METAL SHOWN  
SCALE: 20X



4224642/D 07/2024

NOTES: (continued)

- 6. Publication IPC-7351 may have alternate designs.
- 7. Solder mask tolerances between and around signal pads can vary based on board fabrication site.



SOLDER PASTE EXAMPLE  
BASED ON 0.125 mm THICK STENCIL  
SCALE: 20X

4224642/D 07/2024

NOTES: (continued)

- 8. Laser cutting apertures with trapezoidal walls and rounded corners may offer better paste release. IPC-7525 may have alternate design recommendations.
- 9. Board assembly site may have different recommendations for stencil design.

## IMPORTANT NOTICE AND DISCLAIMER

TI PROVIDES TECHNICAL AND RELIABILITY DATA (INCLUDING DATA SHEETS), DESIGN RESOURCES (INCLUDING REFERENCE DESIGNS), APPLICATION OR OTHER DESIGN ADVICE, WEB TOOLS, SAFETY INFORMATION, AND OTHER RESOURCES "AS IS" AND WITH ALL FAULTS, AND DISCLAIMS ALL WARRANTIES, EXPRESS AND IMPLIED, INCLUDING WITHOUT LIMITATION ANY IMPLIED WARRANTIES OF MERCHANTABILITY, FITNESS FOR A PARTICULAR PURPOSE OR NON-INFRINGEMENT OF THIRD PARTY INTELLECTUAL PROPERTY RIGHTS.

These resources are intended for skilled developers designing with TI products. You are solely responsible for (1) selecting the appropriate TI products for your application, (2) designing, validating and testing your application, and (3) ensuring your application meets applicable standards, and any other safety, security, regulatory or other requirements.

These resources are subject to change without notice. TI grants you permission to use these resources only for development of an application that uses the TI products described in the resource. Other reproduction and display of these resources is prohibited. No license is granted to any other TI intellectual property right or to any third party intellectual property right. TI disclaims responsibility for, and you will fully indemnify TI and its representatives against, any claims, damages, costs, losses, and liabilities arising out of your use of these resources.

TI's products are provided subject to [TI's Terms of Sale](#) or other applicable terms available either on [ti.com](https://www.ti.com) or provided in conjunction with such TI products. TI's provision of these resources does not expand or otherwise alter TI's applicable warranties or warranty disclaimers for TI products.

TI objects to and rejects any additional or different terms you may have proposed.

Mailing Address: Texas Instruments, Post Office Box 655303, Dallas, Texas 75265

Copyright © 2025, Texas Instruments Incorporated