

SN74LVC1G17B-Q1 Automotive Single Schmitt-Trigger Buffer

1 Features

- AEC-Q100 qualified for automotive applications:
 - Device temperature grade 1: -40°C to +125°C
- Operating range from 1.1V to 5.5V
- 5.5V tolerant input pins
- Supports standard pinouts
- Latch-up performance exceeds 100mA per JESD 78

2 Applications

- [Enable or disable a digital signal](#)
- [Eliminate slow or noisy input signals](#)
- [Hold a signal during controller reset](#)
- [Debounce a switch](#)

3 Description

The SN74LVC1G17B-Q1 device contains one buffer and performs the Boolean function $Y = A$. The device functions as an independent buffer with Schmitt-trigger inputs, so the device has different input threshold levels for positive-going (V_{T+}) and negative-going (V_{T-}) signals to provide hysteresis (ΔV_T) which makes the device tolerant to slow or noisy input signals.

Package Information

| PART NUMBER | PACKAGE ⁽¹⁾ | PACKAGE SIZE ⁽²⁾ | BODY SIZE ⁽³⁾ |
|-----------------|------------------------|-----------------------------|--------------------------|
| SN74LVC1G17B-Q1 | DBV (SOT-23, 5) | 2.9mm × 2.8mm | 2.9mm × 1.6mm |
| | DCK (SC70, 5) | 2mm × 2.1mm | 2mm × 1.25mm |
| | DTX (X2SON, 5) | 1.1mm × 0.85mm | 1.1mm × 0.85mm |

- (1) For more information, see [Mechanical, Packaging, and Orderable Information](#).
- (2) The package size (length × width) is a nominal value and includes pins, where applicable.
- (3) The body size (length × width) is a nominal value and does not include pins.

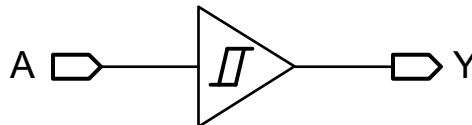

Logic Diagram



Table of Contents

| | | | |
|--------------------------------------------------|----|----------------------------------------------------------------------|----|
| 1 Features | 1 | 7.4 Device Functional Modes..... | 11 |
| 2 Applications | 1 | 8 Application and Implementation | 12 |
| 3 Description | 1 | 8.1 Application Information..... | 12 |
| 4 Pin Configuration and Functions | 3 | 8.2 Typical Application..... | 12 |
| 5 Specifications | 4 | 8.3 Power Supply Recommendations..... | 14 |
| 5.1 Absolute Maximum Ratings..... | 4 | 8.4 Layout..... | 14 |
| 5.2 ESD Ratings..... | 4 | 9 Device and Documentation Support | 16 |
| 5.3 Recommended Operating Conditions..... | 4 | 9.1 Documentation Support..... | 16 |
| 5.4 Thermal Information..... | 4 | 9.2 Receiving Notification of Documentation Updates.... | 16 |
| 5.5 Electrical Characteristics..... | 5 | 9.3 Support Resources..... | 16 |
| 5.6 Switching Characteristics..... | 7 | 9.4 Trademarks..... | 16 |
| 5.7 Typical Characteristics..... | 7 | 9.5 Electrostatic Discharge Caution..... | 16 |
| 6 Parameter Measurement Information | 9 | 9.6 Glossary..... | 16 |
| 7 Detailed Description | 10 | 10 Revision History | 16 |
| 7.1 Overview..... | 10 | 11 Mechanical, Packaging, and Orderable Information | 17 |
| 7.2 Functional Block Diagram..... | 10 | | |
| 7.3 Feature Description..... | 10 | | |

4 Pin Configuration and Functions

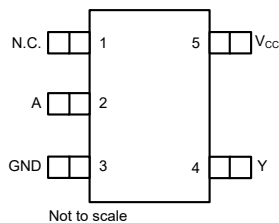

Figure 4-1. DCK , DBV Package 5-Pin SC70 , SOT-23 Top View

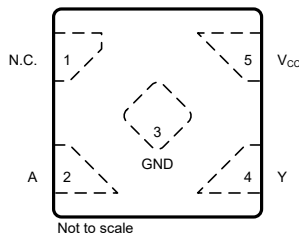

Figure 4-2. DTX Package 5-PIN X2SON Top View

Table 4-1. Pin Functions

| PIN | | TYPE ⁽¹⁾ | DESCRIPTION |
|-----------------|-----|---------------------|------------------------|
| NAME | NO. | | |
| A | 2 | I | Input |
| GND | 3 | G | Ground |
| N.C. | 1 | - | No internal connection |
| V _{CC} | 5 | P | Power supply |
| Y | 4 | O | Output |

(1) I = input, O = Output, P = Power, G = Ground

5 Specifications

5.1 Absolute Maximum Ratings

over operating free-air temperature range (unless otherwise noted)⁽¹⁾

| | | | MIN | MAX | UNIT |
|------------------|----------------------------------------------------------|------------------------|------|-----------------------|------|
| V _{CC} | Supply voltage range | | -0.5 | 6.5 | V |
| V _I | Input voltage range ⁽²⁾ | | -0.5 | 6.5 | V |
| V _O | Output voltage range ⁽²⁾ | | -0.5 | V _{CC} + 0.5 | V |
| I _{IK} | Input diode clamp current | V _I < -0.5V | | -50 | mA |
| I _{OK} | Output diode clamp current | V _O < -0.5V | | -50 | mA |
| I _O | Continuous output current | | | ±50 | mA |
| I _O | Continuous output current through V _{CC} or GND | | | ±100 | mA |
| T _J | Junction temperature | | -65 | 150 | °C |
| T _{stg} | Storage temperature | | -65 | 150 | °C |

- (1) Operation outside the *Absolute Maximum Ratings* may cause permanent device damage. Absolute maximum ratings do not imply functional operation of the device at these or any other conditions beyond those listed under *Recommended Operating Conditions*. If briefly operating outside the *Recommended Operating Conditions* but within the *Absolute Maximum Ratings*, the device may not sustain damage, but it may not be fully functional. Operating the device in this manner may affect device reliability, functionality, performance, and shorten the device lifetime.
- (2) The input and output negative voltage ratings may be exceeded if the input and output current ratings are observed.

5.2 ESD Ratings

| | | | VALUE | UNIT |
|--------------------|-------------------------|----------------------------------------------------------------------------------------|-------|------|
| V _(ESD) | Electrostatic discharge | Human body model (HBM), per AEC Q100-002 HBM ESD Classification Level 2 ⁽¹⁾ | ±2000 | V |
| | | Charged device model (CDM), per AEC Q100-011 CDM ESD Classification Level C4B | ±1000 | |

- (1) AEC Q100-002 indicate that HBM stressing shall be in accordance with the ANSI/ESDA/JEDEC JS-001 specification.

5.3 Recommended Operating Conditions

over operating free-air temperature range (unless otherwise noted)

| Specifications | Description | Condition | MIN | MAX | UNIT |
|-----------------|------------------------------------|--------------------------------|-----|-----------------|------|
| V _{CC} | Supply voltage | | 1.1 | 5.5 | V |
| V _I | Input voltage | | 0 | 5.5 | V |
| V _O | Output voltage - High or Low state | | 0 | V _{CC} | V |
| Δt/Δv | Input transition rise or fall rate | V _{CC} = 1.1V to 5.5V | | 100 | ms/V |
| T _A | Operating free-air temperature | | -40 | 125 | °C |

5.4 Thermal Information

| PACKAGE | PINS | THERMAL METRIC ⁽¹⁾ | | | | | | UNIT |
|-----------------|------|-------------------------------|-----------------------|------------------|-----------------|-----------------|-----------------------|------|
| | | R _{θJA} | R _{θJC(top)} | R _{θJB} | Ψ _{JT} | Ψ _{JB} | R _{θJC(bot)} | |
| DBV (SOT-23, 5) | 5 | 357.1 | 263.7 | 264.4 | 195.6 | 262.2 | - | °C/W |
| DCK (SC70, 5) | 5 | 371.0 | 297.5 | 258.6 | 195.6 | 256.2 | - | °C/W |
| DTX (X2SON, 5) | 5 | 393.6 | 103.2 | 331.8 | 69.8 | 331.9 | 179.9 | °C/W |

- (1) For more information about traditional and new thermal metrics, see the [Semiconductor and IC Package Thermal Metrics](#) application note.

5.5 Electrical Characteristics

over operating free-air temperature range (unless otherwise noted)

| PARAMETER | TEST CONDITIONS | V _{CC} | -40°C to 125°C | | | UNIT |
|-----------------|-------------------------------------------------|-----------------|-----------------------|------|------|------|
| | | | MIN | TYP | MAX | |
| V _{T+} | Positive-going input threshold voltage | 1.1V | 0.5 | 0.77 | 0.9 | V |
| | | 1.3V | 0.6 | 0.89 | 1.0 | |
| | | 1.65V | 0.76 | 1.08 | 1.16 | |
| | | 1.95V | 0.6 | 1.12 | 1.5 | |
| | | 2.3V | 1.08 | 1.35 | 1.56 | |
| | | 2.7V | 0.8 | 1.47 | 2 | |
| | | 3V | 1.3 | 1.66 | 1.92 | |
| | | 3.6V | 1.6 | 1.83 | 2.2 | |
| | | 4.5V | 2.16 | 2.37 | 2.74 | |
| | | 5.5V | 2.61 | 2.86 | 3.33 | |
| V _{T-} | Negative-going input threshold voltage | 1.1V | 0.2 | 0.37 | 0.6 | V |
| | | 1.3V | 0.26 | 0.45 | 0.65 | |
| | | 1.65V | 0.35 | 0.57 | 0.7 | |
| | | 1.95V | 0.5 | 0.6 | 0.8 | |
| | | 2.3V | 0.56 | 0.79 | 0.89 | |
| | | 2.7V | 0.8 | 0.86 | 1.1 | |
| | | 3V | 0.84 | 1.04 | 1.2 | |
| | | 3.6V | 1.1 | 1.37 | 1.7 | |
| | | 4.5V | 1.41 | 1.59 | 1.97 | |
| | | 5.5V | 1.71 | 1.94 | 2.4 | |
| ΔV _T | Hysteresis (V _{T+} - V _{T-}) | 1.1V | 0.25 | 0.49 | 0.53 | V |
| | | 1.3V | 0.25 | 0.50 | 0.54 | |
| | | 1.65V | 0.3 | 0.52 | 0.8 | |
| | | 1.95V | 0.4 | 0.53 | 0.7 | |
| | | 2.3V | 0.4 | 0.56 | 0.78 | |
| | | 2.7V | 0.5 | 0.6 | 0.8 | |
| | | 3V | 0.4 | 0.62 | 0.87 | |
| | | 3.6V | 0.4 | 0.65 | 0.95 | |
| | | 4.5V | 0.58 | 0.78 | 1.04 | |
| | | 5.5V | 0.69 | 0.91 | 1.14 | |
| V _{OH} | I _{OH} = -100μA | 1.1V to 5.5V | V _{CC} - 0.1 | | | V |
| | I _{OH} = -4mA | 1.65V | 1.2 | | | |
| | I _{OH} = -8mA | 2.3V | 1.9 | | | |
| | I _{OH} = -12mA | 2.7V | 2.2 | | | |
| | I _{OH} = -16mA | 3V | 2.4 | | | |
| | I _{OH} = -24mA | 3V | 2.3 | | | |
| | I _{OH} = -32mA | 4.5V | 3.8 | | | |

5.5 Electrical Characteristics (continued)

over operating free-air temperature range (unless otherwise noted)

| PARAMETER | TEST CONDITIONS | V _{CC} | -40°C to 125°C | | | UNIT |
|------------------|------------------------------------------------------------------------------|--------------------------------|----------------|-----|------|------|
| | | | MIN | TYP | MAX | |
| V _{OL} | I _{OL} = 100 μA | 1.1V to 5.5V | | | 0.2 | V |
| | I _{OL} = 4mA | 1.65V | | | 0.45 | |
| | I _{OL} = 8mA | 2.3V | | | 0.3 | |
| | I _{OL} = 12mA | 2.7V | | | 0.4 | |
| | I _{OL} = 16mA | 3V | | | 0.4 | |
| | I _{OL} = 24mA | 3V | | | 0.55 | |
| | I _{OL} = 32mA | 4.5V | | | 0.55 | |
| I _I | V _I = V _{CC} or GND | V _{CC} = 0V to 5.5V | | ±1 | ±5 | μA |
| I _{OFF} | V _I or V _O = V _{CC} | V _{CC} = 0V | | ±1 | ±10 | μA |
| I _{OZ} | V _O = V _{CC} or GND | 5.5V | | ±1 | ±15 | μA |
| I _{CC} | V _I = V _{CC} or GND, I _O = 0 | V _{CC} = 1.1V to 5.5V | | 1 | 10 | μA |
| ΔI _{CC} | One input at V _{CC} - 0.6 V, other inputs at V _{CC} or GND | 3.0V to 5.5V | | | 500 | μA |
| C _I | V _I = V _{CC} or GND | 3.3V | | 3.5 | | pF |
| C _O | V _O = V _{CC} or GND | 3.3V | | 6.3 | | pF |

5.6 Switching Characteristics

over operating free-air temperature range; typical values measured at $T_A = 25^\circ\text{C}$ (unless otherwise noted). See *Parameter Measurement Information*

| PARAMETER | FROM (INPUT) | TO (OUTPUT) | LOAD CONDITIONS | V_{CC} | -40°C to 125°C | | | UNIT |
|-------------------------------|--------------|-------------|---------------------|--------------------------------|----------------|-----|------|------|
| | | | | | MIN | TYP | MAX | |
| t_{pd} | A | Y | $C_L = 15\text{pF}$ | $1.2\text{V} \pm 0.1\text{V}$ | | | 53.5 | ns |
| | | | | $1.5\text{V} \pm 0.12\text{V}$ | | | 12.7 | |
| | | | | $1.8\text{V} \pm 0.15\text{V}$ | | | 8.1 | |
| | | | | $2.5\text{V} \pm 0.2\text{V}$ | | | 5.1 | |
| | | | | $3.3\text{V} \pm 0.3\text{V}$ | | | 4.2 | |
| | | | | $5.0\text{V} \pm 0.5\text{V}$ | | | 3.3 | |
| | | | $C_L = 30\text{pF}$ | $1.8\text{V} \pm 0.15\text{V}$ | | | 8.8 | |
| | | | | $2.5\text{V} \pm 0.2\text{V}$ | | | 5.5 | |
| | | | $C_L = 50\text{pF}$ | $3.3\text{V} \pm 0.3\text{V}$ | | | 4.9 | |
| $5.0\text{V} \pm 0.5\text{V}$ | | | | 3.8 | | | | |
| C_{pd} | | | $f = 10\text{MHz}$ | 1.8V | | | 17.6 | pF |
| | | | | 2.5V | | | 18.9 | |
| | | | | 3.3V | | | 20 | |
| | | | | 5V | | | 21.3 | |

5.7 Typical Characteristics

$T_A = 25^\circ\text{C}$ (unless otherwise noted)

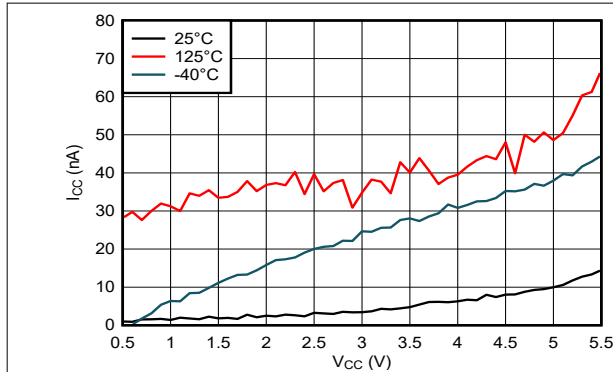

Figure 5-1. Supply Current Across Supply Voltage

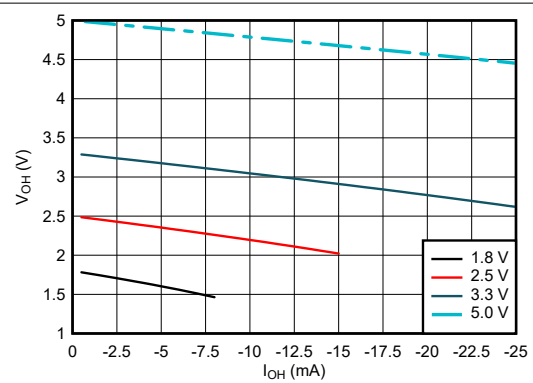

Figure 5-2. Output Voltage vs Current in HIGH State

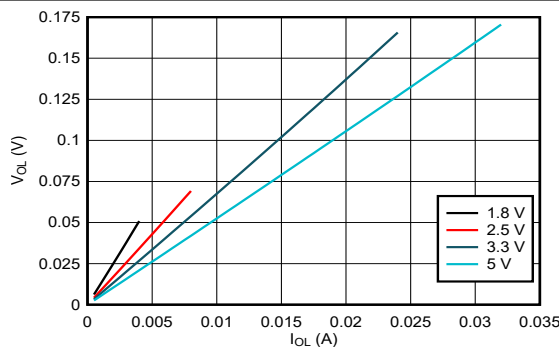

Figure 5-3. Output Voltage vs Current in LOW State

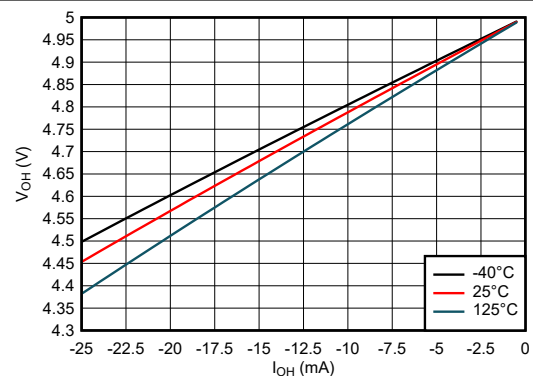

Figure 5-4. Output Voltage vs Current in HIGH State; 5V Supply

5.7 Typical Characteristics (continued)

$T_A = 25^\circ\text{C}$ (unless otherwise noted)

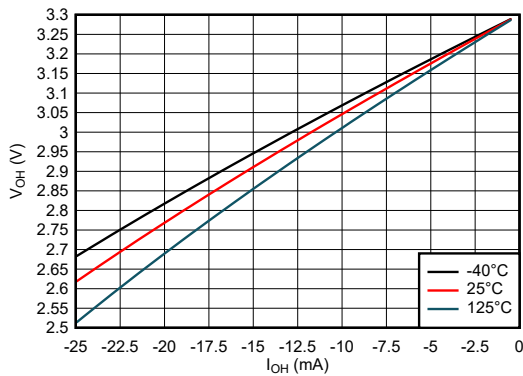

Figure 5-5. Output Voltage vs Current in HIGH State; 3.3V Supply



Figure 5-6. Output Voltage vs Current in HIGH State; 2.5V Supply

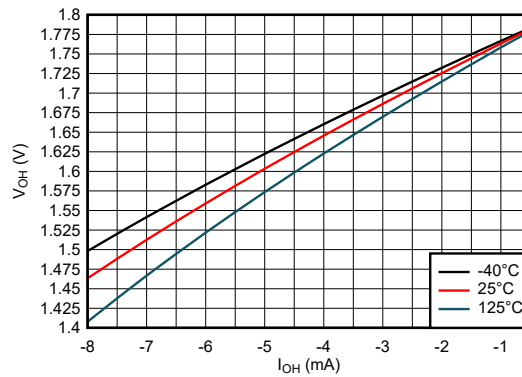

Figure 5-7. Output Voltage vs Current in HIGH State; 1.8V Supply

6 Parameter Measurement Information

Phase relationships between waveforms were chosen arbitrarily for the examples listed in the following table. All input pulses are supplied by generators having the following characteristics: $PRR \leq 1\text{MHz}$, $Z_O = 50\Omega$, $t_f \leq 2.5\text{ns}$.

The outputs are measured individually with one input transition per measurement.

Table 6-1. Push-Pull Outputs

| V_{CC} | V_t | R_L | C_L | ΔV |
|--------------------------------|---------------|-------------------|---------------------------|----------------|
| $1.2\text{V} \pm 0.1\text{V}$ | $V_{CC}/2$ | $2\text{k}\Omega$ | 15pF | 0.1V |
| $1.5\text{V} \pm 0.12\text{V}$ | $V_{CC}/2$ | $2\text{k}\Omega$ | 15pF | 0.1V |
| $1.8\text{V} \pm 0.15\text{V}$ | $V_{CC}/2$ | $1\text{k}\Omega$ | $15\text{pF}/30\text{pF}$ | 0.15V |
| $2.5\text{V} \pm 0.2\text{V}$ | $V_{CC}/2$ | 500Ω | $15\text{pF}/30\text{pF}$ | 0.15V |
| $3.3\text{V} \pm 0.3\text{V}$ | 1.5V | 500Ω | $15\text{pF}/50\text{pF}$ | 0.3V |
| $5.0\text{V} \pm 0.5\text{V}$ | 1.5V | 500Ω | $15\text{pF}/50\text{pF}$ | 0.3V |

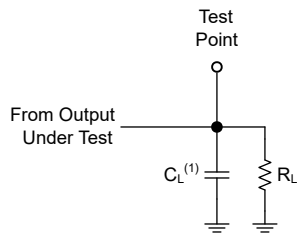

(1) C_L includes probe and test-fixture capacitance.

Figure 6-1. Load Circuit for Push-Pull Outputs

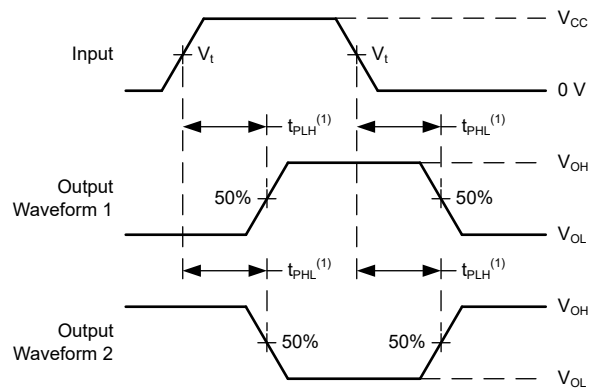

(1) The greater between t_{PLH} and t_{PHL} is the same as t_{pd} .

Figure 6-2. Voltage Waveforms Propagation Delays

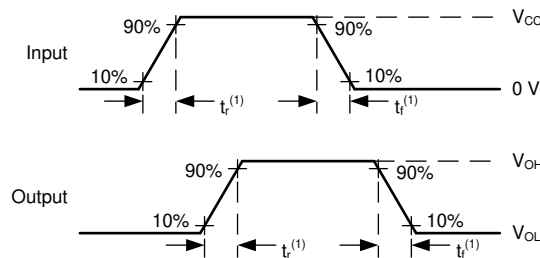

(1) The greater between t_r and t_f is the same as t_t .

Figure 6-3. Voltage Waveforms, Input and Output Transition Times

7 Detailed Description

7.1 Overview

The SN74LVC1G17B-Q1 device contains one Schmitt Trigger buffer and performs the Boolean function $Y = A$. The device functions as an independent buffer, but because of Schmitt Trigger action, it will have different input threshold levels for a positive-going (V_{t+}) and negative-going (V_{t-}) signals.

This device is fully specified for partial-power-down applications using I_{off} . The I_{off} circuit disables the output, preventing damaging current back-flow through the device when it is powered down.

7.2 Functional Block Diagram



7.3 Feature Description

7.3.1 Balanced CMOS Push-Pull Outputs

This device includes balanced CMOS push-pull outputs. The term *balanced* indicates that the device can sink and source similar currents. The drive capability of this device can create fast edges into light loads, so routing and load conditions must be considered to prevent ringing. Additionally, the outputs of this device are capable of driving larger currents than the device can sustain without being damaged. Limit the output power of the device to avoid damage due to overcurrent. The electrical and thermal limits defined in the *Absolute Maximum Ratings* must be followed at all times.

Unused push-pull CMOS outputs must be left disconnected.

7.3.2 CMOS Schmitt-Trigger Inputs

This device includes inputs with the Schmitt-trigger architecture. These inputs are high impedance and are typically modeled as a resistor in parallel with the input capacitance given in the *Electrical Characteristics* table from the input to ground. The worst case resistance is calculated with the maximum input voltage, given in the *Absolute Maximum Ratings* table, and the maximum input leakage current, given in the *Electrical Characteristics* table, using Ohm's law ($R = V \div I$).

The Schmitt-trigger input architecture provides hysteresis as defined by ΔV_T in the *Electrical Characteristics* table, which makes this device extremely tolerant to slow or noisy inputs. While the inputs can be driven much slower than standard CMOS inputs, properly terminating unused inputs is still recommended. Driving the inputs with slow transitioning signals increases dynamic current consumption of the device. For additional information regarding Schmitt-trigger inputs, please see [Understanding Schmitt Triggers](#).

7.3.3 Partial Power Down (I_{off})

This device includes circuitry to disable all outputs when the supply pin is held at 0V. When disabled, the outputs neither source nor sink current, regardless of the input voltages. The amount of leakage current at each output is defined by the I_{off} specification in the *Electrical Characteristics* table.

7.3.4 Clamp Diode Structure

Figure 7-1 shows the inputs and outputs to this device have negative clamping diodes only.

CAUTION

Voltages beyond the values specified in the *Absolute Maximum Ratings* table can cause damage to the device. The input and output voltage ratings may be exceeded if the input and output clamp-current ratings are observed.

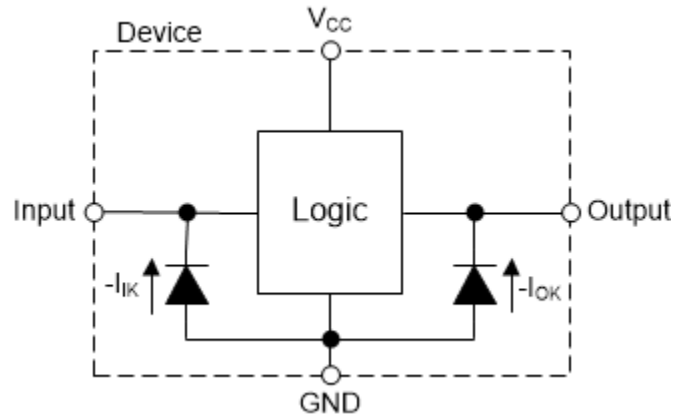

Figure 7-1. Electrical Placement of Clamping Diodes for Each Input and Output

7.4 Device Functional Modes

Function Table shows the functional modes of the SN74LVC1G17B-Q1 device.

Table 7-1. Function Table

| INPUT A | OUTPUT Y |
|------------|-------------|
| H | H |
| L | L |

8 Application and Implementation

Note

Information in the following applications sections is not part of the TI component specification, and TI does not warrant its accuracy or completeness. TI's customers are responsible for determining suitability of components for their purposes, as well as validating and testing their design implementation to confirm system functionality.

8.1 Application Information

The device is a high-drive CMOS device that can be used for a multitude of buffer type functions where the input is slow or noisy. The device can produce 24mA of drive current at 3.3V, making it ideal for driving multiple outputs and good for high-speed applications up to 100MHz. The inputs are 5.5V tolerant allowing it to translate down to V_{CC} .

8.2 Typical Application

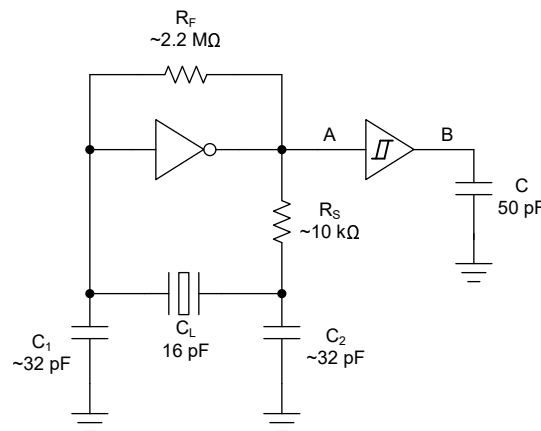

Figure 8-1. Typical Application Schematic

8.2.1 Design Requirements

8.2.1.1 Power Considerations

Verify that the desired supply voltage is within the range specified in the *Electrical Characteristics*. The supply voltage sets the device electrical characteristics, as described in the *Electrical Characteristics* section.

The positive voltage supply must be capable of sourcing current equal to the total current to be sourced by all outputs of the SN74LVC1G17B-Q1 plus the maximum static supply current, I_{CC} , listed in the *Electrical Characteristics*, and any transient current required for switching. The logic device can only source as much current that is provided by the positive supply source. Verify that the maximum total current through V_{CC} listed in the *Absolute Maximum Ratings* is not exceeded.

The ground must be capable of sinking current equal to the total current to be sunk by all outputs of the SN74LVC1G17B-Q1 plus the maximum supply current, I_{CC} , listed in the *Electrical Characteristics*, and any transient current required for switching. The logic device can only sink as much current that can be sunk into the ground connection. Verify that the maximum total current through GND listed in the *Absolute Maximum Ratings* is not exceeded.

The SN74LVC1G17B-Q1 can drive a load with a total capacitance less than or equal to 50pF while still meeting all of the datasheet specifications. Larger capacitive loads can be applied; however, do not exceed 50pF.

The SN74LVC1G17B-Q1 can drive a load with total resistance described by $R_L \geq V_O / I_O$, with the output voltage and current defined in the *Electrical Characteristics* table with V_{OH} and V_{OL} . When outputting in the HIGH state,

the output voltage in the equation is defined as the difference between the measured output voltage and the supply voltage at the V_{CC} pin.

Total power consumption can be calculated using the information provided in the [CMOS Power Consumption and Cpd Calculation application note](#).

Thermal increase can be calculated using the information provided in the [Thermal Characteristics of Standard Linear and Logic \(SLL\) Packages and Devices application note](#).

CAUTION

The maximum junction temperature, $T_{J(max)}$ listed in the *Absolute Maximum Ratings*, is an additional limitation to prevent damage to the device. Do not violate any values listed in the *Absolute Maximum Ratings*. These limits are provided to prevent damage to the device.

8.2.1.2 Input Considerations

Input signals must cross $V_{t-(min)}$ to be considered a logic LOW, and $V_{t+(max)}$ to be considered a logic HIGH. Do not exceed the maximum input voltage range found in the *Absolute Maximum Ratings*.

Unused inputs must be terminated to either V_{CC} or ground. The unused inputs can be directly terminated if the input is completely unused, or the inputs can be connected with a pullup or pulldown resistor if the input is used sometimes, but not always. A pullup resistor is used for a default state of HIGH, and a pulldown resistor is used for a default state of LOW. The drive current of the controller, leakage current into the SN74LVC1G17B-Q1 (as specified in the *Electrical Characteristics*), and the desired input transition rate limits the resistor size. A 10k Ω resistor value is often used due to these factors.

The SN74LVC1G17B-Q1 has no input signal transition rate requirements because the device has Schmitt-Trigger inputs.

Another benefit to having Schmitt-Trigger inputs is the ability to reject noise. Noise with a large enough amplitude can still cause issues. To know how much noise is too much, please refer to the $\Delta V_{T(min)}$ in the *Electrical Characteristics*. This hysteresis value provides the peak-to-peak limit.

Unlike what happens with standard CMOS inputs, Schmitt-Trigger inputs can be held at any valid value without causing huge increases in power consumption. The typical additional current caused by holding an input at a value other than V_{CC} or ground is plotted in the *Typical Characteristics*.

Refer to the *Feature Description* for additional information regarding the inputs for this device.

8.2.1.3 Output Considerations

The positive supply voltage is used to produce the output HIGH voltage. Drawing current from the output decreases the output voltage as specified by the V_{OH} specification in the *Electrical Characteristics*. The ground voltage is used to produce the output LOW voltage. Sinking current into the output increases the output voltage as specified by the V_{OL} specification in the *Electrical Characteristics*.

Push-pull outputs that can be in opposite states, even for a very short time period, must never be connected directly together. This can cause excessive current and damage to the device.

Two channels within the same device with the same input signals can be connected in parallel for additional output drive strength.

Unused outputs can be left floating. Do not connect outputs directly to V_{CC} or ground.

Refer to the *Feature Description* section for additional information regarding the outputs for this device.

8.2.2 Detailed Design Procedure

1. Add a decoupling capacitor from V_{CC} to GND. The capacitor needs to be placed physically close to the device and electrically close to both the V_{CC} and GND pins. An example layout is shown in the *Layout* section.

2. Verify that the capacitive load at the output is $\leq 50\text{pF}$. Low load capacitance can be accomplished by providing short, appropriately sized traces from the SN74LVC1G17B-Q1 to the receiving device.
3. Verify that the resistive load at the output is larger than $(V_{CC} / I_{O(max)})\Omega$. Never violate the maximum output current from the *Absolute Maximum Ratings*. Most CMOS inputs have a resistive load measured in $M\Omega$; much larger than the minimum calculated previously.
4. Thermal issues are rarely a concern for logic gates; however, the power consumption and thermal increase can be calculated using the steps provided in the [CMOS Power Consumption and Cpd Calculation application note](#).

8.2.3 Application Curve

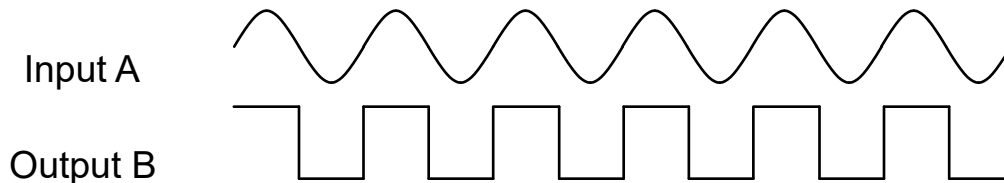

Figure 8-2. Schmitt-Trigger Sinewave Input and Square Wave Output

8.3 Power Supply Recommendations

The power supply can be any voltage between the minimum and maximum supply voltage rating listed in the *Recommended Operating Conditions*.

Verify that each V_{CC} terminal has a good bypass capacitor to prevent power disturbance. For the SN74LVC1G17B-Q1, a $0.1\mu\text{F}$ bypass capacitor is recommended. To reject different frequencies of noise, use multiple bypass capacitors in parallel. Capacitors with values of $0.1\mu\text{F}$ and $1\mu\text{F}$ are commonly used in parallel.

8.4 Layout

8.4.1 Layout Guidelines

- Bypass capacitor placement
 - Place near the positive supply terminal of the device
 - Provide an electrically short ground return path
 - Use wide traces to minimize impedance
 - Keep the device, capacitors, and traces on the same side of the board whenever possible
- Signal trace geometry
 - 8mil to 12mil trace width
 - Lengths less than 12cm to minimize transmission line effects
 - Avoid 90° corners for signal traces
 - Use an unbroken ground plane below signal traces
 - Flood fill areas around signal traces with ground
 - Parallel traces must be separated by at least 3x dielectric thickness
 - For traces longer than 12cm
 - Use impedance controlled traces
 - Source-terminate using a series damping resistor near the output
 - Avoid branches; buffer each signal that must branch separately

8.4.2 Layout Example

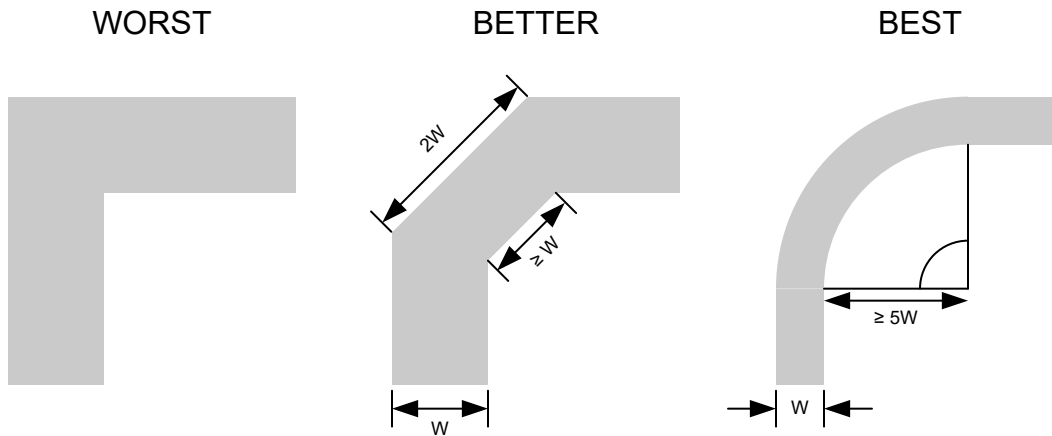

Figure 8-3. Example Trace Corners for Improved Signal Integrity

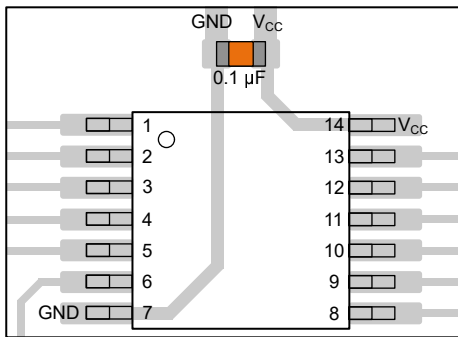

Figure 8-4. Example Bypass Capacitor Placement for TSSOP and Similar Packages

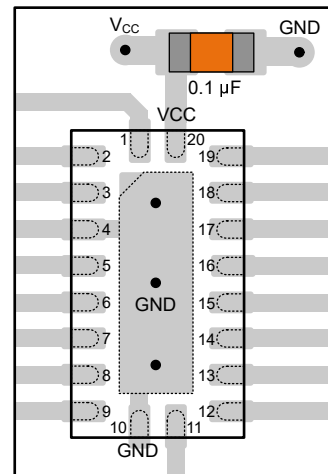

Figure 8-5. Example Bypass Capacitor Placement for WQFN and Similar Packages

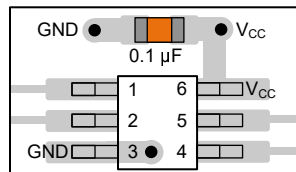

Figure 8-6. Example Bypass Capacitor Placement for SOT, SC70 and Similar Packages

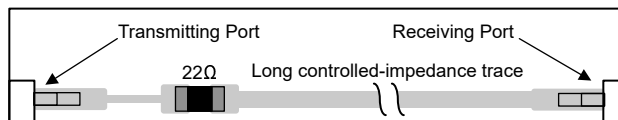

Figure 8-7. Example Damping Resistor Placement for Improved Signal Integrity

9 Device and Documentation Support

TI offers an extensive line of development tools. Tools and software to evaluate the performance of the device, generate code, and develop solutions are listed below.

9.1 Documentation Support

9.1.1 Related Documentation

For related documentation, see the following:

- Texas Instruments, [CMOS Power Consumption and \$C_{pd}\$ Calculation application note](#)
- Texas Instruments, [Designing With Logic application note](#)
- Texas Instruments, [Thermal Characteristics of Standard Linear and Logic \(SLL\) Packages and Devices application note](#)

9.2 Receiving Notification of Documentation Updates

To receive notification of documentation updates, navigate to the device product folder on [ti.com](#). Click on *Notifications* to register and receive a weekly digest of any product information that has changed. For change details, review the revision history included in any revised document.

9.3 Support Resources

TI E2E™ [support forums](#) are an engineer's go-to source for fast, verified answers and design help — straight from the experts. Search existing answers or ask your own question to get the quick design help you need.

Linked content is provided "AS IS" by the respective contributors. They do not constitute TI specifications and do not necessarily reflect TI's views; see TI's [Terms of Use](#).

9.4 Trademarks

TI E2E™ is a trademark of Texas Instruments.
All trademarks are the property of their respective owners.

9.5 Electrostatic Discharge Caution



This integrated circuit can be damaged by ESD. Texas Instruments recommends that all integrated circuits be handled with appropriate precautions. Failure to observe proper handling and installation procedures can cause damage.

ESD damage can range from subtle performance degradation to complete device failure. Precision integrated circuits may be more susceptible to damage because very small parametric changes could cause the device not to meet its published specifications.

9.6 Glossary

[TI Glossary](#) This glossary lists and explains terms, acronyms, and definitions.

10 Revision History

NOTE: Page numbers for previous revisions may differ from page numbers in the current version.

| DATE | REVISION | NOTES |
|-----------|----------|-----------------|
| June 2026 | * | Initial Release |

11 Mechanical, Packaging, and Orderable Information

The following pages include mechanical, packaging, and orderable information. This information is the most current data available for the designated devices. This data is subject to change without notice and revision of this document. For browser-based versions of this data sheet, refer to the left-hand navigation.

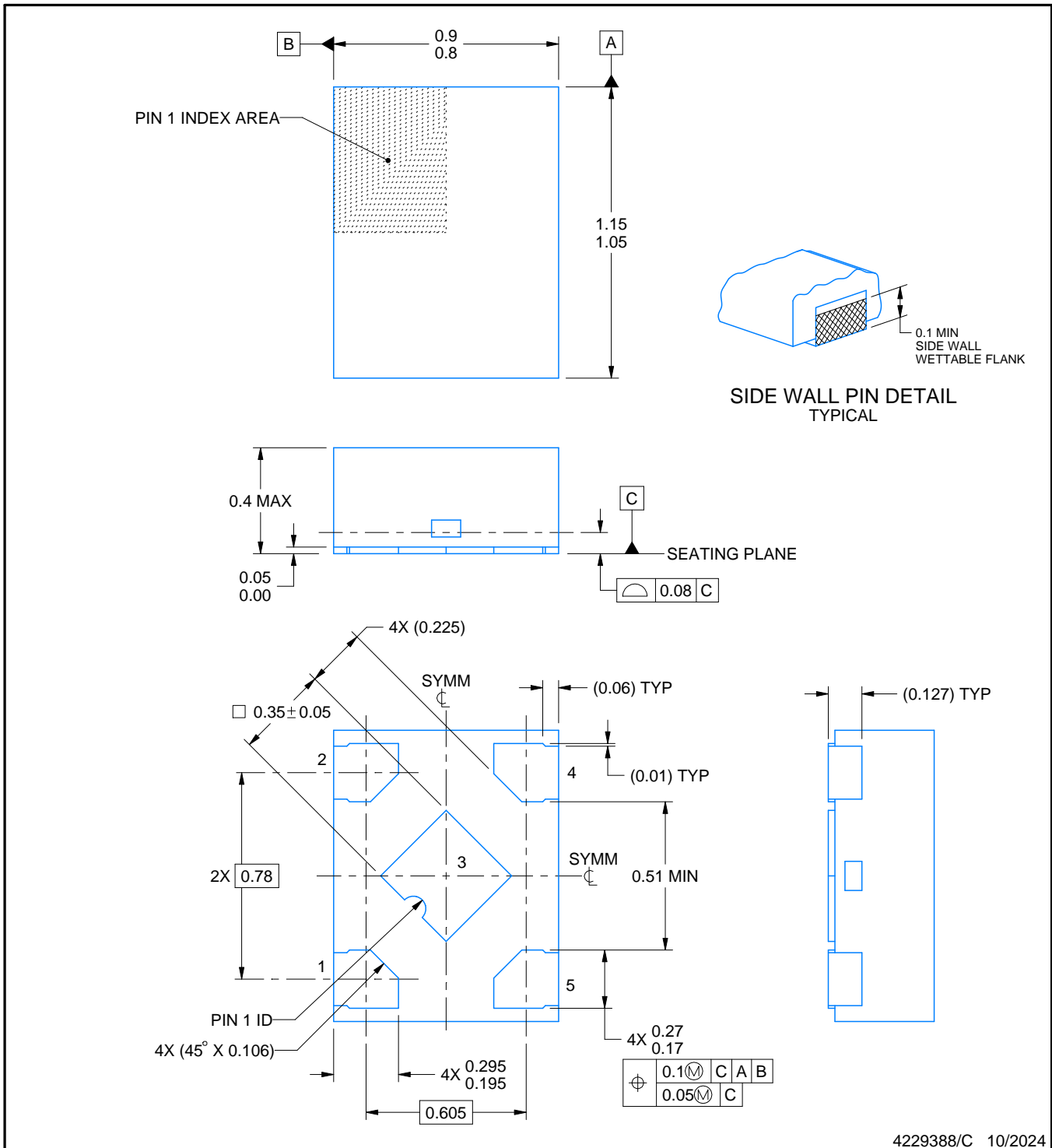
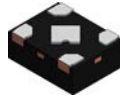

NOTES:

1. All linear dimensions are in millimeters. Any dimensions in parenthesis are for reference only. Dimensioning and tolerancing per ASME Y14.5M.
2. This drawing is subject to change without notice.
3. The package thermal pad must be soldered to the printed circuit board for thermal and mechanical performance.

EXAMPLE BOARD LAYOUT

DTX0005A

X2SON - 0.4 mm max height

PLASTIC SMALL OUTLINE - NO LEAD

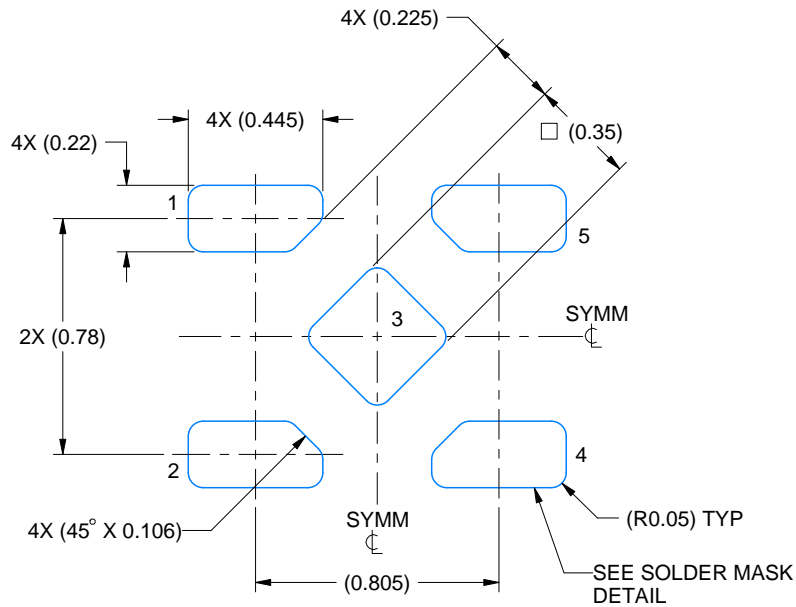

LAND PATTERN EXAMPLE
EXPOSED METAL SHOWN
SCALE: 40X

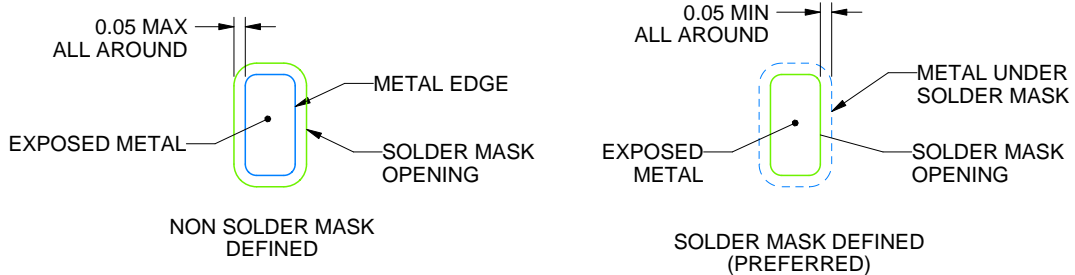

SOLDER MASK DETAILS

4229388/C 10/2024

NOTES: (continued)

4. This package is designed to be soldered to a thermal pad on the board. For more information, see Texas Instruments literature number SLUA271 (www.ti.com/lit/slua271).

EXAMPLE STENCIL DESIGN

DTX0005A

X2SON - 0.4 mm max height

PLASTIC SMALL OUTLINE - NO LEAD

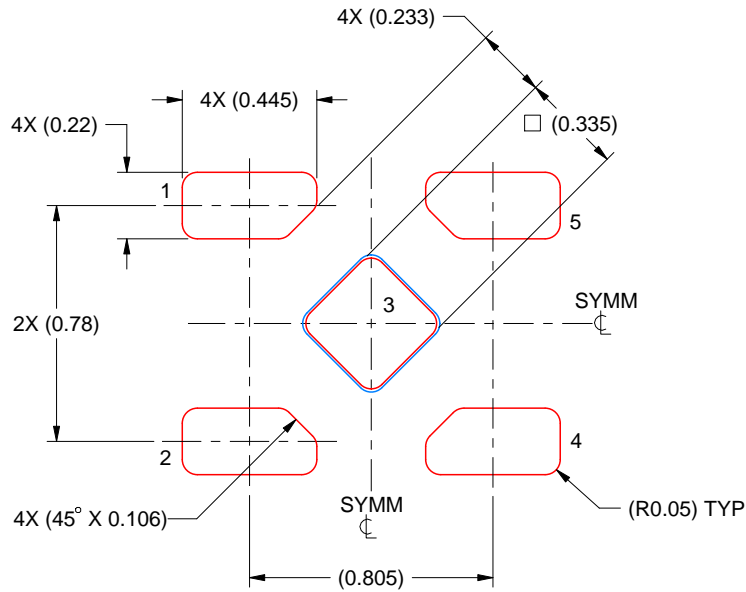

SOLDER PASTE EXAMPLE
BASED ON 0.1 mm THICK STENCIL
SCALE: 40X

PRINTED SOLDER PASTE COVERAGE BY AREA UNDER PACKAGE
PAD 5: 92%

4229388/C 10/2024

NOTES: (continued)

5. Laser cutting apertures with trapezoidal walls and rounded corners may offer better paste release. IPC-7525 may have alternate design recommendations.

IMPORTANT NOTICE AND DISCLAIMER

TI PROVIDES TECHNICAL AND RELIABILITY DATA (INCLUDING DATASHEETS), DESIGN RESOURCES (INCLUDING REFERENCE DESIGNS), APPLICATION OR OTHER DESIGN ADVICE, WEB TOOLS, SAFETY INFORMATION, AND OTHER RESOURCES "AS IS" AND WITH ALL FAULTS, AND DISCLAIMS ALL WARRANTIES, EXPRESS AND IMPLIED, INCLUDING WITHOUT LIMITATION ANY IMPLIED WARRANTIES OF MERCHANTABILITY, FITNESS FOR A PARTICULAR PURPOSE OR NON-INFRINGEMENT OF THIRD PARTY INTELLECTUAL PROPERTY RIGHTS.

These resources are intended for skilled developers designing with TI products. You are solely responsible for (1) selecting the appropriate TI products for your application, (2) designing, validating and testing your application, and (3) ensuring your application meets applicable standards, and any other safety, security, regulatory or other requirements.

These resources are subject to change without notice. TI grants you permission to use these resources only for development of an application that uses the TI products described in the resource. Other reproduction and display of these resources is prohibited. No license is granted to any other TI intellectual property right or to any third party intellectual property right. TI disclaims responsibility for, and you fully indemnify TI and its representatives against any claims, damages, costs, losses, and liabilities arising out of your use of these resources.

TI's products are provided subject to [TI's Terms of Sale](#), [TI's General Quality Guidelines](#), or other applicable terms available either on ti.com or provided in conjunction with such TI products. TI's provision of these resources does not expand or otherwise alter TI's applicable warranties or warranty disclaimers for TI products. Unless TI explicitly designates a product as custom or customer-specified, TI products are standard, catalog, general purpose devices.

TI objects to and rejects any additional or different terms you may propose.

Copyright © 2026, Texas Instruments Incorporated

Last updated 10/2025