

TDEL3G510 Triple Falling Edge Delay Elements

1 Features

- 1% typical, 10% maximum delay variation
- Pre-configured digital timing - no external timing components required
- Wide operating range from 1.65V to 5.5V
- I/O clamp diodes protect from over- and under-voltage transients
- Schmitt-trigger architecture on all inputs

2 Applications

- Delay the falling edge of a signal
- Extend a short active-high pulse
- Filter out short active-low pulses
- Debounce an active-high signal

3 Description

The TDEL3G510 devices contain three independent fixed-time falling-edge delay blocks. Each channel delays the input signal falling edge by a predetermined amount, while allowing rising edges to pass through with minimal delay.

Package Information

PART NUMBER	PACKAGE ⁽¹⁾	PACKAGE SIZE ⁽²⁾	BODY SIZE ⁽³⁾
TDEL3G510	DRL (SOT-5X3, 8)	2.1mm × 1.6mm	2.1mm × 1.6mm

(1) For all available packages, see the orderable addendum at the end of the data sheet.

(2) The package size (length × width) is a nominal value and includes pins, where applicable.

(3) The body size (length × width) is a nominal value and does not include pins.

Device Information

PART NUMBER	DELAY TIME ⁽¹⁾
TDEL1G51000	100ms

(1) Approximate values shown; see [Section 5.8](#) for details

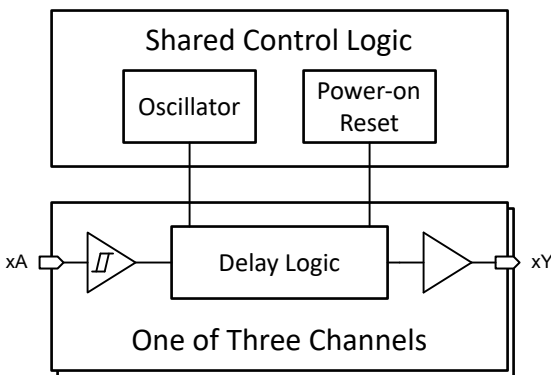

Functional Block Diagram

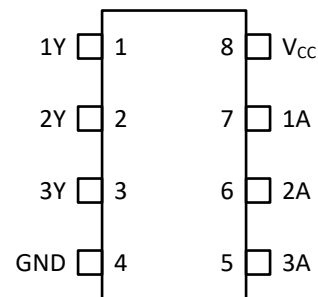

Pinout Diagram



Table of Contents

1 Features	1	7.4 Device Functional Modes.....	12
2 Applications	1	8 Application and Implementation	13
3 Description	1	8.1 Application Information.....	13
4 Pin Configuration and Functions	3	8.2 Typical Application.....	13
5 Specifications	4	8.3 Power Supply Recommendations.....	15
5.1 Absolute Maximum Ratings.....	4	8.4 Layout.....	15
5.2 ESD Ratings.....	4	9 Device and Documentation Support	17
5.3 Recommended Operating Conditions.....	4	9.1 Device Support.....	17
5.4 Thermal Information.....	5	9.2 Documentation Support.....	17
5.5 Electrical Characteristics.....	5	9.3 Receiving Notification of Documentation Updates....	17
5.6 Timing Characteristics.....	6	9.4 Support Resources.....	17
5.7 Switching Characteristics.....	6	9.5 Trademarks.....	17
5.8 Typical Characteristics.....	8	9.6 Electrostatic Discharge Caution.....	17
6 Parameter Measurement Information	9	9.7 Glossary.....	17
7 Detailed Description	10	10 Revision History	17
7.1 Overview.....	10	11 Mechanical, Packaging, and Orderable Information	18
7.2 Functional Block Diagram.....	10		
7.3 Feature Description.....	10		

4 Pin Configuration and Functions

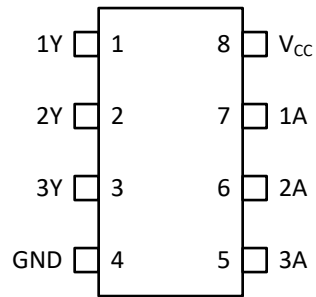

Figure 4-1. TDEL3G510 DRL Package (Top View)

Pin Functions

PIN		TYPE ⁽¹⁾	DESCRIPTION
NAME	DRL NO.		
1A	7	I	Channel 1 input
1Y	1	O	Channel 1 output
2A	6	I	Channel 2 input
2Y	2	O	Channel 2 output
3A	5	I	Channel 3 input
3Y	3	O	Channel 3 output
GND	4	G	Ground
V _{CC}	8	P	Positive supply

(1) Signal Types: I = Input, O = Output, G = Ground, P = Power.

5 Specifications

5.1 Absolute Maximum Ratings

over operating free-air temperature range (unless otherwise noted)⁽¹⁾

			MIN	MAX	UNIT
V_{CC}	Supply voltage range		-0.5	6.5	V
V_I	Digital input voltage range ⁽²⁾		-0.5	$V_{CC} + 0.5$	V
V_O	Digital output voltage range in the active state ⁽³⁾		-0.5	$V_{CC} + 0.5$	V
I_{IK}	Input clamp diode current, continuous	$V_I < -0.5V$ or $V_I > V_{CC} + 0.5$		± 20	mA
	Input clamp diode current, pulsed 1 μ s	$V_I < -0.5V$ or $V_I > V_{CC} + 0.5$		± 200	mA
I_{OK}	Output clamp diode current, continuous	$V_I < -0.5V$ or $V_I > V_{CC} + 0.5$		± 20	mA
	Output clamp diode current, pulsed 1 μ s	$V_I < -0.5V$ or $V_I > V_{CC} + 0.5$		± 200	mA
I_O	Digital output current, continuous	$V_O = 0$ to V_{CC}		± 20	mA
	Digital output current, pulsed 1 μ s	$V_O = 0$ to V_{CC}		± 100	mA
	Continuous current through V_{CC} or GND			± 60	mA
T_J	Junction temperature			150	$^{\circ}C$
T_{stg}	Storage temperature		-65	150	$^{\circ}C$

- (1) Operation outside the *Absolute Maximum Ratings* may cause permanent device damage. Absolute maximum ratings do not imply functional operation of the device at these or any other conditions beyond those listed under *Recommended Operating Conditions*. If briefly operating outside the *Recommended Operating Conditions* but within the *Absolute Maximum Ratings*, the device may not sustain damage, but it may not be fully functional. Operating the device in this manner may affect device reliability, functionality, performance, and shorten the device lifetime.
- (2) The voltage ratings may be exceeded if the associated clamp current ratings are observed.
- (3) The timing capacitance maximum value can be exceeded if an external diode is added. See *Application and Implementation* section for details.

5.2 ESD Ratings

			VALUE	UNIT
$V_{(ESD)}$	Electrostatic discharge	Human-body model (HBM), per ANSI/ESDA/JEDEC JS-001 ⁽¹⁾	± 2000	V
		Charged-device model (CDM), per ANSI/ESDA/JEDEC JS-002 ⁽²⁾	± 1000	

- (1) JEDEC document JEP155 states that 500V HBM allows safe manufacturing with a standard ESD control process.
- (2) JEDEC document JEP157 states that 250V CDM allows safe manufacturing with a standard ESD control process.

5.3 Recommended Operating Conditions

over operating free-air temperature range (unless otherwise noted)

			MIN	MAX	UNIT
V_{CC}	Supply voltage		1.65	5.5	V
V_I	Input Voltage ⁽¹⁾		0	V_{CC}	V
V_O	Output Voltage		0	V_{CC}	V
I_{OH} ⁽²⁾	High-level output current	$V_{CC} = 1.65V$ to $2.2V$		-6	mA
		$V_{CC} = 2.3V$ to $5.5V$		-20	mA
I_{OL} ⁽²⁾	Low-level output current	$V_{CC} = 1.65V$ to $5.5V$		20	mA
C_L	Digital output load capacitance	$V_{CC} = 1.65V$ to $5.5V$		50	pF
V_{POR}	Power-on reset ramp voltage	$\Delta t/\Delta V_{CC} \geq 20\mu s/V$	0.3	1.5	V
$\Delta t/\Delta V_{CC}$	Power-on ramp rate	$V_{CC} = 0.3V$ to $1.5V$	20		$\mu s/V$
$\Delta t/\Delta v$	Input transition rise or fall rate	$V_{CC} = 1.65V$ to $5.5V$		100	ms/V

5.3 Recommended Operating Conditions (continued)

over operating free-air temperature range (unless otherwise noted)

		MIN	MAX	UNIT
T_A	Operating free-air temperature	-40	125	°C

- (1) All unused inputs of the device must be held at V_{CC} or GND to ensure proper device operation.
- (2) Recommended maximum output current for continuous operation; see *Electrical Characteristics* for test current values to maintain V_{OH} and V_{OL} specifications. Operating with average output current greater than 12mA may impact device reliability and shorten the device lifetime.

5.4 Thermal Information

PACKAGE	PINS	THERMAL METRIC ⁽¹⁾						UNIT
		$R_{\theta JA}$	$R_{\theta JC(top)}$	$R_{\theta JB}$	Ψ_{JT}	Ψ_{JB}	$R_{\theta JC(bot)}$	
DRL (SOT-5X3)	8	118.4	77.1	26.5	3.9	25.9	N/A	°C/W

- (1) For more information about traditional and new thermal metrics, see the [Semiconductor and IC Package Thermal Metrics](#) application note.

5.5 Electrical Characteristics

Over operating free-air temperature range; typical values measured at $T_A = 25^\circ\text{C}$ (unless otherwise noted)

PARAMETER		TEST CONDITIONS	V_{CC}	MIN	TYP	MAX	UNIT
V_{T+}	Positive switching threshold		1.65V	0.84	1.02	1.21	V
			1.8V	0.91	1.11	1.31	
			2.5V	1.24	1.48	1.72	
			3.3V	1.59	1.85	2.13	
			5V	2.29	2.65	3.03	
			5.5V	2.5	2.88	3.3	
V_{T-}	Negative switching threshold		1.65V	0.51	0.67	0.85	V
			1.8V	0.58	0.74	0.93	
			2.5V	0.88	1.07	1.29	
			3.3V	1.19	1.42	1.68	
			5V	1.8	2.11	2.47	
			5.5V	1.99	2.32	2.71	
ΔV_T	Hysteresis ($V_{T+} - V_{T-}$)		1.65V	0.23	0.36	0.49	V
			1.8V	0.24	0.37	0.5	
			2.5V	0.29	0.40	0.54	
			3.3V	0.34	0.44	0.55	
			5V	0.44	0.53	0.63	
			5.5V	0.47	0.57	0.66	
V_{OH}	High-level output voltage	$I_{OH} = -50\mu\text{A}$	1.65V - 5.5V	$V_{CC} - 0.1$	$V_{CC} - 0.01$		V
		$I_{OH} = -1\text{mA}$	1.65V	1.5	1.6		
		$I_{OH} = -2\text{mA}$	2.3V	2.1	2.2		
		$I_{OH} = -8\text{mA}$	3V	2.3	2.6		
		$I_{OH} = -12\text{mA}$	4.5V	3.6	4		
		$I_{OH} = -12\text{mA}$	5.5V	4.7	5		

5.5 Electrical Characteristics (continued)

Over operating free-air temperature range; typical values measured at $T_A = 25^\circ\text{C}$ (unless otherwise noted)

PARAMETER		TEST CONDITIONS	V_{CC}	MIN	TYP	MAX	UNIT
V_{OL}	Low-level output voltage	$I_{OL} = 50\mu\text{A}$	1.65V - 5.5V		0.01	0.1	V
		$I_{OL} = 1\text{mA}$	1.65V		0.01	0.1	
		$I_{OL} = 2\text{mA}$	2.3V		0.02	0.1	
		$I_{OL} = 8\text{mA}$	3V		0.05	0.2	
		$I_{OL} = 12\text{mA}$	4.5V		0.06	0.2	
		$I_{OL} = 12\text{mA}$	5.5V		0.06	0.2	
I_{CC}	Supply current	Active state using low speed oscillator ⁽¹⁾ , $V_I = V_{CC}$ or GND, $I_O = 0$	1.65V		6	8	μA
			2.3V		7	9	
			3V		8	11	
			4.5V		12	19	
			5.5V		16	26	
ΔI_{CC}	Supply-current change	One input, $0 < V_I < V_{CC}$, all other inputs at V_{CC} or GND, $I_O = 0$	1.65V - 5.5V			0.7	mA
C_I		$V_I = 5.5\text{V}$ or GND	5.5V		3		pF

(1) See *Typical Characteristics* for a table of which devices use each oscillator.

5.6 Timing Characteristics

over recommended operating free-air temperature range (unless otherwise noted)

PARAMETER	DESCRIPTION	CONDITION	V_{CC}	MIN	MAX	UNIT
t_{wi} ⁽¹⁾	Pulse width	Any input	1.8V \pm 0.15V		10	ns
			2.5V \pm 0.2V		10	
			3.3V \pm 0.3V		10	
			5V \pm 0.5V		10	
$t_{startup}$ ⁽²⁾	Startup time		1.65V - 5.5V		265	μs

(1) Minimum input pulse width to activate the timing circuitry inside the TDEL family device. Active state operation increases power consumption but may not change the output state. See *Detailed Description* section for operation details.

(2) Outputs are in the high-impedance state until startup time expires.

5.7 Switching Characteristics

over operating free-air temperature range; typical values measured at $T_A = 25^\circ\text{C}$ (unless otherwise noted). See *Parameter Measurement Information*.

PARAMETER	FROM (INPUT)	TO (OUTPUT)	TEST CONDITIONS	V_{CC}	MIN	TYP	MAX	UNIT
t_{plh}	Any input	Any output	$C_L = 15\text{pF}$	1.65V			121	ns
				2.3V			107	
				3V			101	
				4.5V			96.4	
				5.5V			94.5	
			$C_L = 50\text{pF}$	1.65V			127	
				2.3V			112	
				3V			105	
				4.5V			98.8	
				5.5V			97	

5.7 Switching Characteristics (continued)

over operating free-air temperature range; typical values measured at $T_A = 25^\circ\text{C}$ (unless otherwise noted). See *Parameter Measurement Information*.

PARAMETER	FROM (INPUT)	TO (OUTPUT)	TEST CONDITIONS	V_{CC}	MIN	TYP	MAX	UNIT
t_t		Any output	$C_L = 15\text{pF}$	1.65V		12	18	ns
				2.3V		9	14	
				3V		8	11	
				4.5V		6	9	
				5.5V		6	9	
			$C_L = 50\text{pF}$	1.65V		22	33	
				2.3V		16	24	
				3V		14	20	
				4.5V		11	16	
				5.5V		10	15	
$\Delta t_{\text{delay}}^{(1)}$		Any output	$C_L = 50\text{pF}$	1.65V to 5.5V	± 1		± 10	%
C_{pd}	Any Input	Any Output	$T = V_{CC}, \bar{T} = \text{GND}, f_i = 1\text{MHz}, C_L = 50\text{pF}$	1.65V		12		pF
				2.3V		9		pF
				3V		8		pF
				4.5V		23		pF
				5.5V		91		pF

(1) Variation in delay time from nominal.

5.8 Typical Characteristics

Table 5-1. Delay Time for Each Device

$T_A = 25^\circ\text{C}$ (unless otherwise noted)

Device	Oscillator	Parameter	Timing Value ⁽¹⁾
TDEL3G51000DRLR	Low speed	t_{delay}	100ms
		t_{osc}	1.28ms

(1) The delay time (t_{delay}) can additionally vary by up to $-t_{\text{osc}}$.

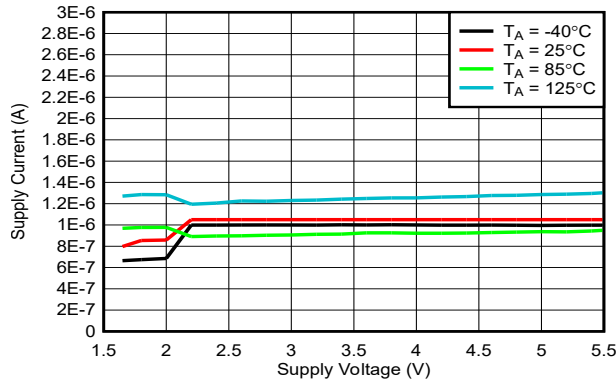

Figure 5-1. Supply Current vs Supply Voltage

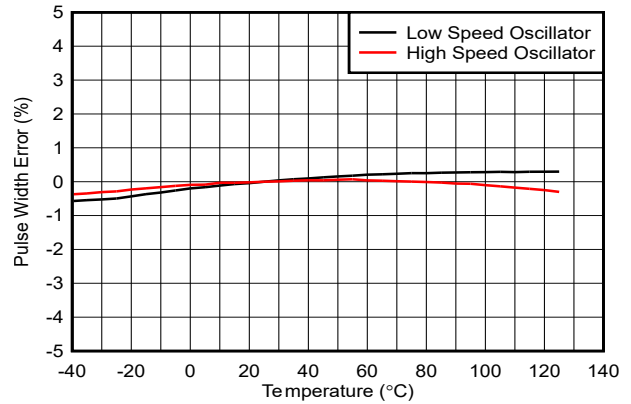

Figure 5-2. Pulse Width Error vs Temperature

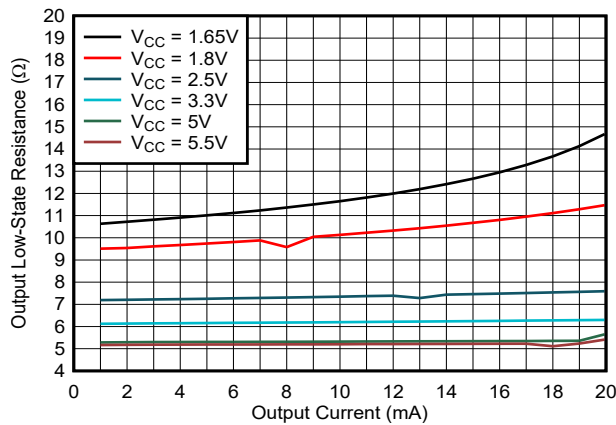

Figure 5-3. Output Low-State Resistance vs Output Current

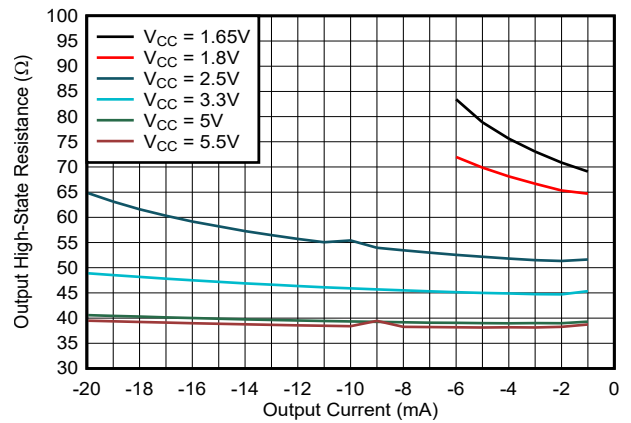
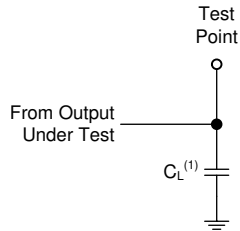

Figure 5-4. Output High-State Resistance vs Output Current

6 Parameter Measurement Information

Phase relationships between waveforms were chosen arbitrarily for the examples listed in the following table. All input pulses are supplied by generators having the following characteristics: $PRR \leq 1\text{MHz}$, $Z_O = 50\Omega$, $t_t < 2.5\text{ns}$.

The outputs are measured individually with one input transition per measurement.



(1) C_L includes probe and test-fixture capacitance.

Figure 6-1. Load Circuit for Push-Pull Outputs

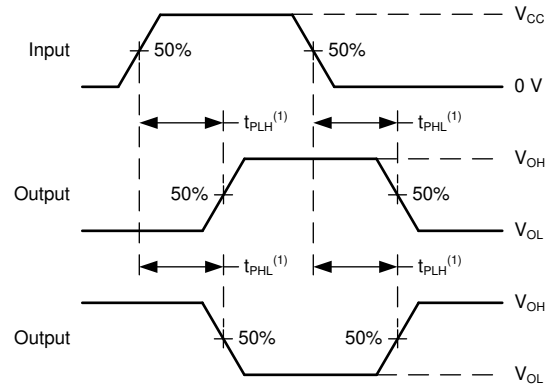

(1) The greater between t_{PLH} and t_{PHL} is the same as t_{pd} .

Figure 6-2. Voltage Waveforms Propagation Delays

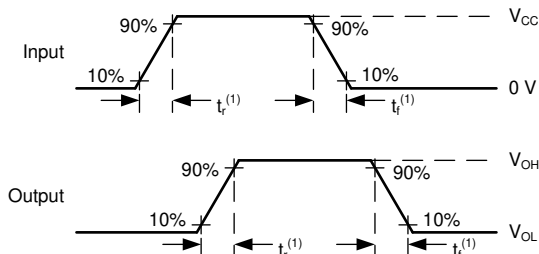

(1) The greater between t_r and t_f is the same as t_t .

Figure 6-3. Voltage Waveforms, Input and Output Transition Times

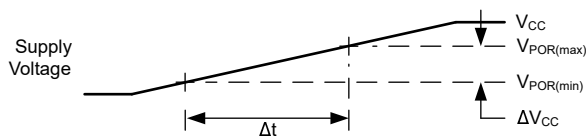

Figure 6-5. Voltage Waveforms, Supply Ramp

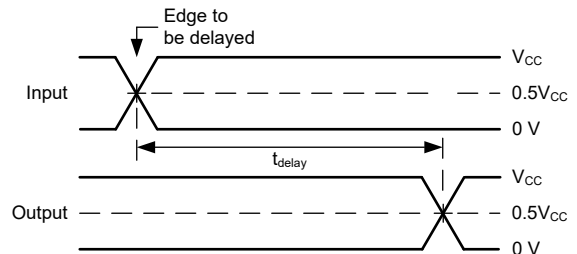

Figure 6-4. Voltage Waveforms, Edge Delay Time

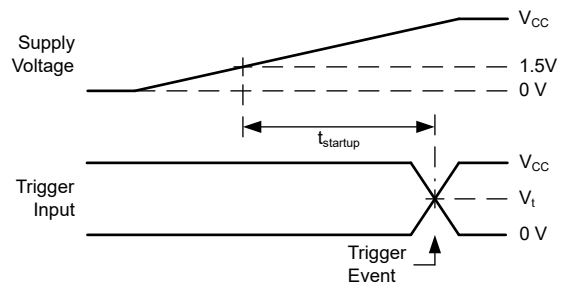

Figure 6-6. Voltage Waveforms, Startup Time

7 Detailed Description

7.1 Overview

The TDEL3G510 device contains three digitally timed falling-edge delay circuits.

When the input transitions from high to low, the internal timer starts. When the timer reaches the predefined delay value, the output transitions from high to low and the timer is disabled. When the input transitions from low to high, the timer is reset and disabled, awaiting the next falling-edge delay operation.

The falling-edge delay feature provides inherent filtering behavior for active-low signals, maintaining the output in the high state as long as the input does not remain low longer than the predefined delay time.

The internal oscillator turns off when not in use. When a delay is being measured, the oscillator is turned on and is shared by all channels.

During the power-up ramp, the outputs remain in a high-impedance state until the internal power-on reset circuit enables normal device operation.

7.2 Functional Block Diagram

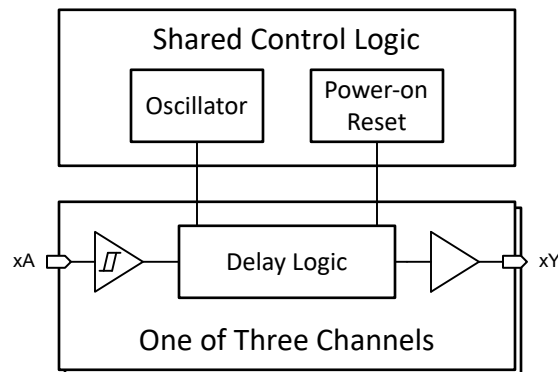

7.3 Feature Description

7.3.1 Naming Convention

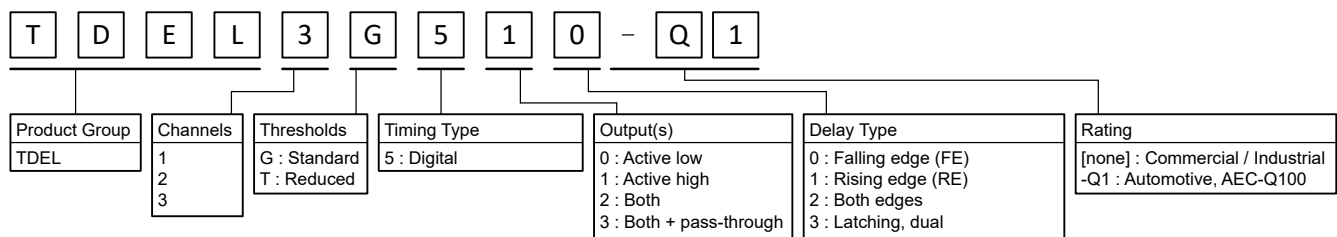

Figure 7-1. Device name meaning

7.3.2 Timing Mechanism and Accuracy

The output delay (t_{delay}) is generated by a factory-trimmed internal oscillator and binary counter. When an edge transition is detected, the oscillator activates and drives the counter until the pre-configured count is reached, at which point the output responds according to the delay type.

The maximum delay error is provided as Δt_{delay} in the *Switching Characteristics* section and includes variations due to voltage, design, manufacturing, and temperature. This variation is given as a percentage of the typical delay provided in the *Typical Characteristics* section.

If one channel is actively timing a delay and another channel is triggered to start timing a delay, then the delay time can be off by up to t_{osc} , given in the *Typical Characteristics* section, due to the asynchronous nature of the inputs.

7.3.3 CMOS Push-Pull Outputs

This device includes CMOS push-pull outputs. The drive capability of this device may create fast edges into light loads, so routing and load conditions should be considered to prevent ringing. Additionally, the outputs of this device are capable of driving larger currents than the device can sustain without being damaged. It is important to limit the output power of the device to avoid damage due to overcurrent. The electrical and thermal limits defined in the *Absolute Maximum Ratings* must be followed at all times.

Unused push-pull CMOS outputs must be left disconnected.

7.3.4 CMOS Schmitt-Trigger Inputs

This device includes inputs with the Schmitt-trigger architecture. These inputs are high impedance and are typically modeled as a resistor in parallel with the input capacitance given in the *Electrical Characteristics* table from the input to ground. The worst case resistance is calculated with the maximum input voltage, given in the *Absolute Maximum Ratings* table, and the maximum input leakage current, given in the *Electrical Characteristics* table, using Ohm's law ($R = V \div I$).

The Schmitt-trigger input architecture provides hysteresis as defined by ΔV_T in the *Electrical Characteristics* table, which makes this device extremely tolerant to slow or noisy inputs. While the inputs can be driven much slower than standard CMOS inputs, it is still recommended to properly terminate unused inputs. Driving the inputs with slow transitioning signals will increase dynamic current consumption of the device with the maximum value per input defined as ΔI_{CC} in the *Electrical Characteristics* table. For additional information regarding Schmitt-trigger inputs, please see [Understanding Schmitt Triggers](#).

Do not leave inputs floating at any time during operation. Unused inputs must be terminated at a valid high or low voltage level. If a system is not actively driving an input at all times, then a pull-up or pull-down resistor can be added to provide a valid input voltage during these times. The resistor value will depend on multiple factors; however, a 10k Ω resistor is recommended and will typically meet all requirements.

7.3.5 Latching Logic with Known Power-Up State

This device includes latching logic circuitry. Latching circuits commonly include D-type latches and D-type flip-flops, but include all logic circuits that act as volatile memory. In typical logic devices, the output state of each latching circuit is unknown after power is initially applied; however, this device includes an added Power On Reset (POR) circuit which sets the states of all included latching circuits during the power-up ramp prior to the device starting normal functionality.

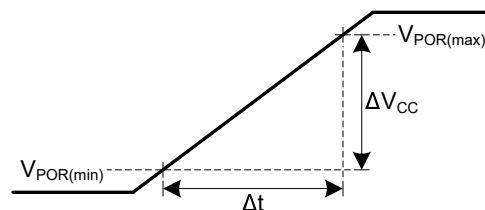

Figure 7-2. Supply (V_{CC}) Ramp Characteristics for Known Power-Up State

Figure 7-2 shows a correct supply voltage turn-on ramp and defines values used in the *Recommended Operating Conditions* and *Electrical Characteristics* tables.

Prior to starting the power-on ramp, the supply must be completely off ($V_{CC} \leq V_{POR(min)}$).

The supply voltage must ramp at a rate within the range provided in the *Recommended Operating Conditions* table.

The output state of each latching logic circuit only remains stable as long as power is applied to the device ($V_{CC} \geq V_{POR(max)}$).

Variation from these recommendations will result in the device having an unknown power-up state.

7.3.6 Clamp Diode Structure

As shown in Figure 7-3, the inputs and outputs to this device have both positive and negative clamping diodes.

CAUTION

Voltages beyond the values specified in the *Absolute Maximum Ratings* table can cause damage to the device. The input and output voltage ratings can be exceeded if the input and output clamp-current ratings are observed.

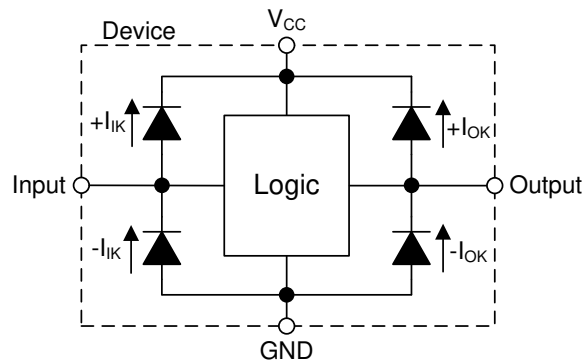

Figure 7-3. Electrical Placement of Clamping Diodes for Each Input and Output

7.4 Device Functional Modes

7.4.1 Startup Operation

The TDEL3G510 includes an internal power-on reset (POR) circuit that prevents erroneous triggers from occurring during startup. There are details on the supply ramp requirements provided in *Latching Logic with Known Power-Up State*. Normal operation can be started after the startup time (t_{startup}) has expired per the *Timing Requirements* table. While active, the POR circuit holds all outputs of the TDEL3G510 in the high-impedance state.

7.4.2 On-State Operation

The table below lists the on-state functional modes for the TDEL3G510.

Table 7-1. Function Table

INPUTS ⁽¹⁾	OUTPUTS ⁽²⁾
A	Y
↑	H
↓	L after preconfigured delay
L	L ⁽³⁾
H	H

- (1) H = high voltage level, L = low voltage level, ↑ = low to high transition, ↓ = high to low transition
- (2) L = driving low, H = driving high
- (3) The output state is based on the assumption that the indicated steady-state condition at the input has been set up long enough to complete any delay.

8 Application and Implementation

Note

Information in the following applications sections is not part of the TI component specification, and TI does not warrant its accuracy or completeness. TI's customers are responsible for determining suitability of components for their purposes, as well as validating and testing their design implementation to confirm system functionality.

8.1 Application Information

The TDEL3G510 is used to add a fixed-time falling-edge delay to a digital input signal. The three most common use cases are: falling-edge delay, pulse stretcher, deglitch/debounce. All three applications are the same logic function with the only difference being the input signal.

8.2 Typical Application

In this application, one channel of the TDEL3G510 is used to delay falling edges on an input signal. The circuit configuration is shown in [Figure 8-1](#).

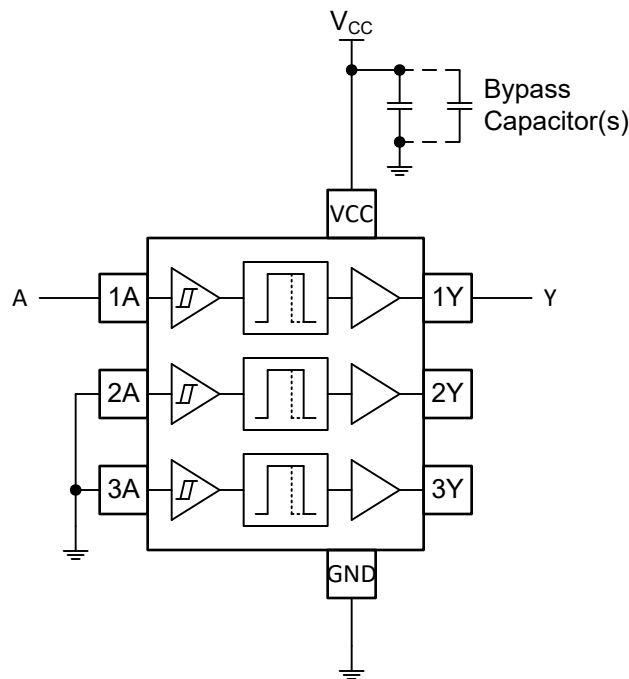

Figure 8-1. Falling Edge Delay Schematic Using the TDEL3G510

8.2.1 Design Requirements

8.2.1.1 Power Considerations

Verify that the desired supply voltage is within the range specified in the *Electrical Characteristics*. The supply voltage sets the device electrical characteristics, as described in the *Electrical Characteristics* section.

The positive voltage supply must be capable of sourcing current equal to the total current to be sourced by all outputs of the TDEL3G510 plus the maximum static supply current, I_{CC} , listed in the *Electrical Characteristics*, and any transient current required for switching. The logic device can only source as much current that is provided by the positive supply source. Verify that the maximum total current through V_{CC} listed in the *Absolute Maximum Ratings* is not exceeded.

The ground must be capable of sinking current equal to the total current to be sunk by all outputs of the TDEL3G510 plus the maximum supply current, I_{CC} , listed in the *Electrical Characteristics*, and any transient

current required for switching. The logic device can only sink as much current that can be sunk into the ground connection. Verify that the maximum total current through GND listed in the *Absolute Maximum Ratings* is not exceeded.

The TDEL3G510 can drive a load with a total capacitance less than or equal to 50pF while still meeting all of the datasheet specifications. Larger capacitive loads can be applied; however, do not exceed 50pF.

The TDEL3G510 can drive a load with total resistance described by $R_L \geq V_O / I_O$, with the output voltage and current defined in the *Electrical Characteristics* table with V_{OH} and V_{OL} . When outputting in the HIGH state, the output voltage in the equation is defined as the difference between the measured output voltage and the supply voltage at the V_{CC} pin.

Total power consumption can be calculated using the information provided in the [CMOS Power Consumption and Cpd Calculation application note](#).

Thermal increase can be calculated using the information provided in the [Thermal Characteristics of Standard Linear and Logic \(SLL\) Packages and Devices application note](#).

CAUTION

The maximum junction temperature, $T_{J(max)}$ listed in the *Absolute Maximum Ratings*, is an additional limitation to prevent damage to the device. Do not violate any values listed in the *Absolute Maximum Ratings*. These limits are provided to prevent damage to the device.

8.2.1.2 Input Considerations

Input signals must cross $V_{t-(min)}$ to be considered a logic LOW, and $V_{t+(max)}$ to be considered a logic HIGH. Do not exceed the maximum input voltage range found in the *Absolute Maximum Ratings*.

Unused inputs must be terminated to either V_{CC} or ground. The unused inputs can be directly terminated if the input is completely unused, or they can be connected with a pull-up or pull-down resistor if the input will be used sometimes, but not always. A pull-up resistor is used for a default state of HIGH, and a pull-down resistor is used for a default state of LOW. The drive current of the controller, leakage current into the TDEL3G510 (as specified in the *Electrical Characteristics*), and the desired input transition rate limits the resistor size. A 10k Ω resistor value is often used due to these factors.

The TDEL3G510 has no input signal transition rate requirements because it has Schmitt-Trigger inputs.

Another benefit to having Schmitt-Trigger inputs is the ability to reject noise. Noise with a large enough amplitude can still cause issues. To know how much noise is too much, please refer to the $\Delta V_{T(min)}$ in the *Electrical Characteristics* table. This hysteresis value will provide the peak-to-peak limit.

Unlike what happens with standard CMOS inputs, Schmitt-Trigger inputs can be held at any valid value without causing huge increases in power consumption. The typical additional current caused by holding an input at a value other than V_{CC} or ground is plotted in the *Typical Characteristics* section.

Refer to the *Feature Description* for additional information regarding the inputs for this device.

8.2.1.3 Output Considerations

The positive supply voltage is used to produce the output HIGH voltage. Drawing current from the output will decrease the output voltage as specified by the V_{OH} specification in the *Electrical Characteristics*. The ground voltage is used to produce the output LOW voltage. Sinking current into the output will increase the output voltage as specified by the V_{OL} specification in the *Electrical Characteristics*.

Push-pull outputs that could be in opposite states, even for a very short time period, should never be connected directly together. This can cause excessive current and damage to the device.

Do not connect two channels in parallel for additional output drive strength. If additional drive strength is required, add an external driver device.

Unused outputs can be left floating. Do not connect outputs directly to V_{CC} or ground.

Refer to the *Feature Description* section for additional information regarding the outputs for this device.

8.2.2 Detailed Design Procedure

1. Add a decoupling capacitor from V_{CC} to GND. The capacitor needs to be placed physically close to the device and electrically close to both the V_{CC} and GND pins. An example layout is shown in the *Layout* section.
2. Verify that the capacitive load at the output is $\leq 50\text{pF}$. Low load capacitance can be accomplished by providing short, appropriately sized traces from the TDEL3G510 to the receiving device.
3. Verify that the resistive load at the output is larger than $(V_{CC} / I_{O(max)})\Omega$. Never violate the maximum output current from the *Absolute Maximum Ratings*. Most CMOS inputs have a resistive load measured in $\text{M}\Omega$; much larger than the minimum calculated previously.
4. Thermal issues are rarely a concern for logic gates; however, the power consumption and thermal increase can be calculated using the steps provided in the [CMOS Power Consumption and Cpd Calculation application note](#).

8.2.3 Application Curves

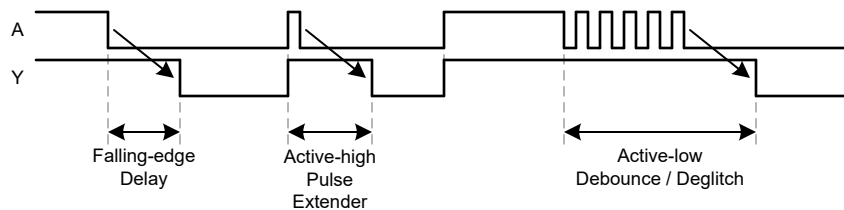

Figure 8-2. Output Timing Diagram

8.3 Power Supply Recommendations

The power supply can be any voltage between the minimum and maximum supply voltage rating listed in the *Recommended Operating Conditions*.

During startup, the power supply should ramp within the provided power-up ramp rate range in the *Recommended Operating Conditions* table.

Each V_{CC} terminal must have a good bypass capacitor to prevent power disturbance. For normal operation of the TDEL3G510, a $0.1\mu\text{F}$ bypass capacitor is recommended. To reject different frequencies of noise, use multiple bypass capacitors in parallel. Capacitors with values of $0.1\mu\text{F}$ and $1\mu\text{F}$ are commonly used in parallel.

8.4 Layout

8.4.1 Layout Guidelines

- Bypass capacitor placement
 - Place near the positive supply terminal of the device
 - Provide an electrically short ground return path
 - Use wide traces to minimize impedance
 - Keep the device, capacitors, and traces on the same side of the board whenever possible
- Signal trace geometry
 - 8mil to 12mil trace width
 - Lengths less than 12cm to minimize transmission line effects
 - Avoid 90° corners for signal traces
 - Use an unbroken ground plane below signal traces
 - Flood fill areas around signal traces with ground
 - Parallel traces must be separated by at least 3x dielectric thickness
 - For traces longer than 12cm
 - Use impedance controlled traces
 - Source-terminate using a series damping resistor near the output
 - Avoid branches; buffer each signal that must branch separately

8.4.2 Layout Example

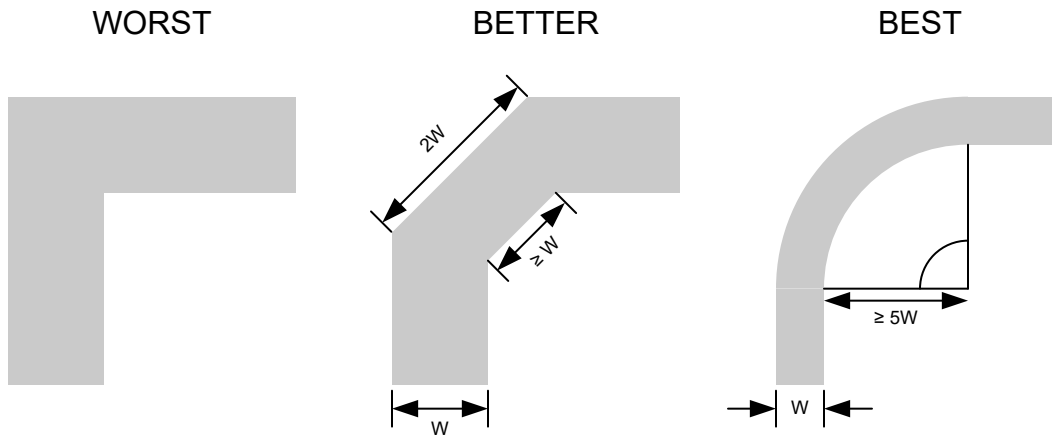

Figure 8-3. Example Trace Corners for Improved Signal Integrity

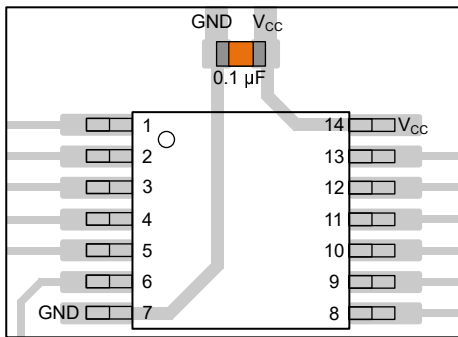

Figure 8-4. Example Bypass Capacitor Placement for TSSOP and Similar Packages

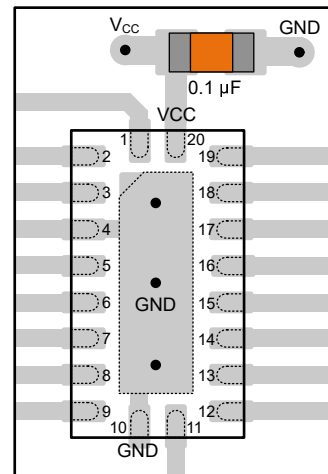

Figure 8-5. Example Bypass Capacitor Placement for WQFN and Similar Packages

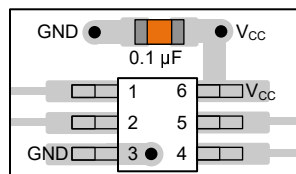

Figure 8-6. Example Bypass Capacitor Placement for SOT, SC70 and Similar Packages

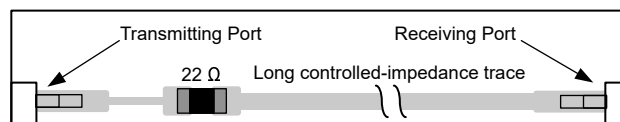

Figure 8-7. Example Damping Resistor Placement for Improved Signal Integrity

9 Device and Documentation Support

TI offers an extensive line of development tools. Tools and software to evaluate the performance of the device, generate code, and develop solutions are listed below.

9.1 Device Support

9.1.1 Device Nomenclature

Table 9-1. Device Nomenclature

PRODUCT ⁽¹⁾	DESCRIPTION
TDEL3G510 xx yyy z	xx is the timing variant. See page 1 for a table of timing options. yyy is the package designator. z indicates the package quantity. R is for large reel (3000 pieces).

(1) For the most current package and ordering information see the Package Option Addendum at the end of this document, or visit the device product folder on www.ti.com.

9.2 Documentation Support

9.2.1 Related Documentation

For related documentation, see the following:

- Texas Instruments, [CMOS Power Consumption and \$C_{pd}\$ Calculation application note](#)
- Texas Instruments, [Designing With Logic application note](#)
- Texas Instruments, [Thermal Characteristics of Standard Linear and Logic \(SLL\) Packages and Devices application note](#)

9.3 Receiving Notification of Documentation Updates

To receive notification of documentation updates, navigate to the device product folder on ti.com. Click on *Notifications* to register and receive a weekly digest of any product information that has changed. For change details, review the revision history included in any revised document.

9.4 Support Resources

[TI E2E™ support forums](#) are an engineer's go-to source for fast, verified answers and design help — straight from the experts. Search existing answers or ask your own question to get the quick design help you need.

Linked content is provided "AS IS" by the respective contributors. They do not constitute TI specifications and do not necessarily reflect TI's views; see TI's [Terms of Use](#).

9.5 Trademarks

TI E2E™ is a trademark of Texas Instruments.
All trademarks are the property of their respective owners.

9.6 Electrostatic Discharge Caution



This integrated circuit can be damaged by ESD. Texas Instruments recommends that all integrated circuits be handled with appropriate precautions. Failure to observe proper handling and installation procedures can cause damage.

ESD damage can range from subtle performance degradation to complete device failure. Precision integrated circuits may be more susceptible to damage because very small parametric changes could cause the device not to meet its published specifications.

9.7 Glossary

[TI Glossary](#) This glossary lists and explains terms, acronyms, and definitions.

10 Revision History

NOTE: Page numbers for previous revisions may differ from page numbers in the current version.

DATE	REVISION	NOTES
March 2026	*	Initial Release

11 Mechanical, Packaging, and Orderable Information

The following pages include mechanical, packaging, and orderable information. This information is the most current data available for the designated devices. This data is subject to change without notice and revision of this document. For browser-based versions of this data sheet, refer to the left-hand navigation.

PACKAGING INFORMATION

Orderable part number	Status (1)	Material type (2)	Package Pins	Package qty Carrier	RoHS (3)	Lead finish/ Ball material (4)	MSL rating/ Peak reflow (5)	Op temp (°C)	Part marking (6)
TDEL3G51000DRLR	Active	Production	SOT-5X3 (DRL) 8	3000 LARGE T&R	-	Call TI	Level-1-260C-UNLIM	-40 to 125	TDD00

(1) **Status:** For more details on status, see our [product life cycle](#).

(2) **Material type:** When designated, preproduction parts are prototypes/experimental devices, and are not yet approved or released for full production. Testing and final process, including without limitation quality assurance, reliability performance testing, and/or process qualification, may not yet be complete, and this item is subject to further changes or possible discontinuation. If available for ordering, purchases will be subject to an additional waiver at checkout, and are intended for early internal evaluation purposes only. These items are sold without warranties of any kind.

(3) **RoHS values:** Yes, No, RoHS Exempt. See the [TI RoHS Statement](#) for additional information and value definition.

(4) **Lead finish/Ball material:** Parts may have multiple material finish options. Finish options are separated by a vertical ruled line. Lead finish/Ball material values may wrap to two lines if the finish value exceeds the maximum column width.

(5) **MSL rating/Peak reflow:** The moisture sensitivity level ratings and peak solder (reflow) temperatures. In the event that a part has multiple moisture sensitivity ratings, only the lowest level per JEDEC standards is shown. Refer to the shipping label for the actual reflow temperature that will be used to mount the part to the printed circuit board.

(6) **Part marking:** There may be an additional marking, which relates to the logo, the lot trace code information, or the environmental category of the part.

Multiple part markings will be inside parentheses. Only one part marking contained in parentheses and separated by a "-" will appear on a part. If a line is indented then it is a continuation of the previous line and the two combined represent the entire part marking for that device.

Important Information and Disclaimer: The information provided on this page represents TI's knowledge and belief as of the date that it is provided. TI bases its knowledge and belief on information provided by third parties, and makes no representation or warranty as to the accuracy of such information. Efforts are underway to better integrate information from third parties. TI has taken and continues to take reasonable steps to provide representative and accurate information but may not have conducted destructive testing or chemical analysis on incoming materials and chemicals. TI and TI suppliers consider certain information to be proprietary, and thus CAS numbers and other limited information may not be available for release.

In no event shall TI's liability arising out of such information exceed the total purchase price of the TI part(s) at issue in this document sold by TI to Customer on an annual basis.

EXAMPLE BOARD LAYOUT

DRL0008A

SOT-5X3 - 0.6 mm max height

PLASTIC SMALL OUTLINE

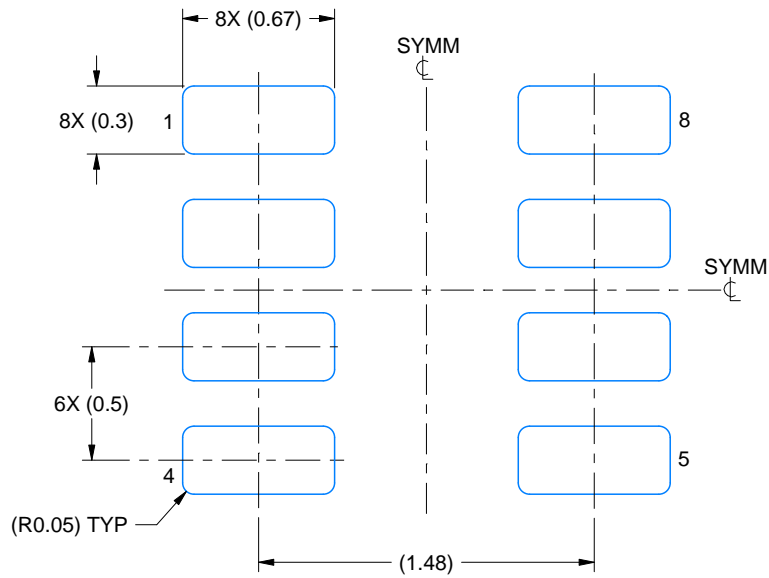

LAND PATTERN EXAMPLE
EXPOSED METAL SHOWN
SCALE:30X

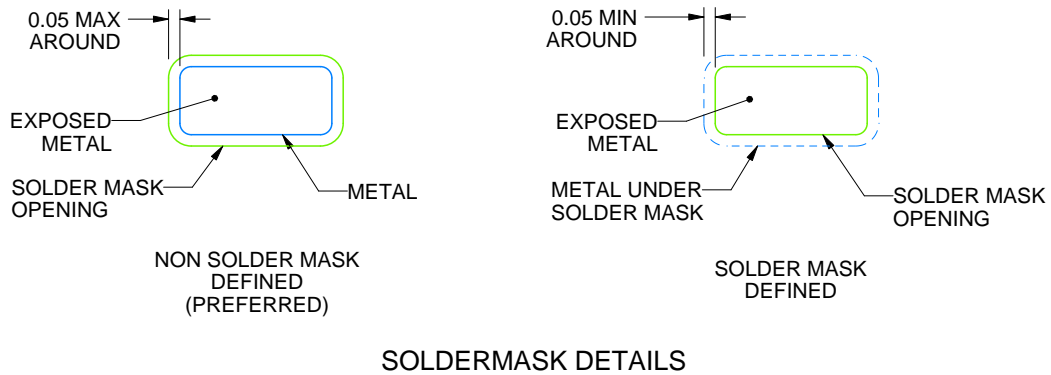

SOLDERMASK DETAILS

4224486/G 11/2024

NOTES: (continued)

5. Publication IPC-7351 may have alternate designs.
6. Solder mask tolerances between and around signal pads can vary based on board fabrication site.
7. Land pattern design aligns to IPC-610, Bottom Termination Component (BTC) solder joint inspection criteria.

EXAMPLE STENCIL DESIGN

DRL0008A

SOT-5X3 - 0.6 mm max height

PLASTIC SMALL OUTLINE

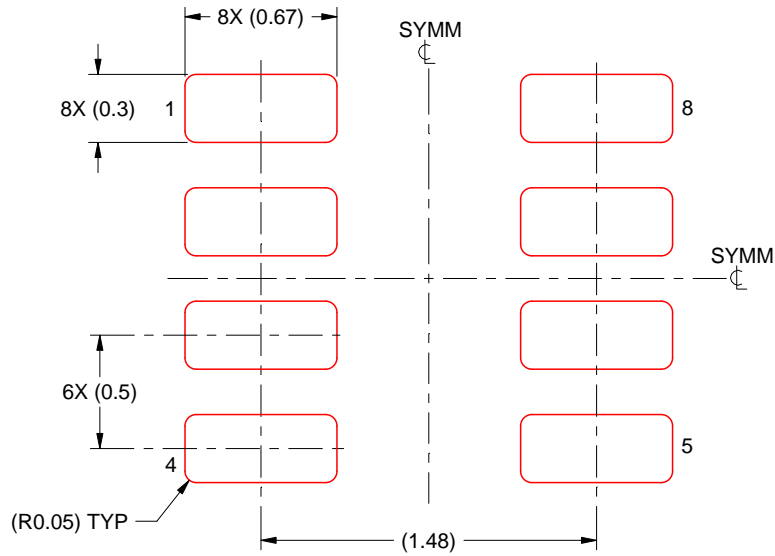

SOLDER PASTE EXAMPLE
BASED ON 0.1 mm THICK STENCIL
SCALE:30X

4224486/G 11/2024

NOTES: (continued)

8. Laser cutting apertures with trapezoidal walls and rounded corners may offer better paste release. IPC-7525 may have alternate design recommendations.
9. Board assembly site may have different recommendations for stencil design.

IMPORTANT NOTICE AND DISCLAIMER

TI PROVIDES TECHNICAL AND RELIABILITY DATA (INCLUDING DATASHEETS), DESIGN RESOURCES (INCLUDING REFERENCE DESIGNS), APPLICATION OR OTHER DESIGN ADVICE, WEB TOOLS, SAFETY INFORMATION, AND OTHER RESOURCES "AS IS" AND WITH ALL FAULTS, AND DISCLAIMS ALL WARRANTIES, EXPRESS AND IMPLIED, INCLUDING WITHOUT LIMITATION ANY IMPLIED WARRANTIES OF MERCHANTABILITY, FITNESS FOR A PARTICULAR PURPOSE OR NON-INFRINGEMENT OF THIRD PARTY INTELLECTUAL PROPERTY RIGHTS.

These resources are intended for skilled developers designing with TI products. You are solely responsible for (1) selecting the appropriate TI products for your application, (2) designing, validating and testing your application, and (3) ensuring your application meets applicable standards, and any other safety, security, regulatory or other requirements.

These resources are subject to change without notice. TI grants you permission to use these resources only for development of an application that uses the TI products described in the resource. Other reproduction and display of these resources is prohibited. No license is granted to any other TI intellectual property right or to any third party intellectual property right. TI disclaims responsibility for, and you fully indemnify TI and its representatives against any claims, damages, costs, losses, and liabilities arising out of your use of these resources.

TI's products are provided subject to [TI's Terms of Sale](#), [TI's General Quality Guidelines](#), or other applicable terms available either on ti.com or provided in conjunction with such TI products. TI's provision of these resources does not expand or otherwise alter TI's applicable warranties or warranty disclaimers for TI products. Unless TI explicitly designates a product as custom or customer-specified, TI products are standard, catalog, general purpose devices.

TI objects to and rejects any additional or different terms you may propose.

Copyright © 2026, Texas Instruments Incorporated

Last updated 10/2025