

TL720M05-Q1 Automotive, 500mA, 40V, Low-Dropout Voltage Regulator

1 Features

- AEC-Q100 qualified for automotive applications:
 - Temperature grade 1: -40°C to $+125^{\circ}\text{C}$, T_A
 - Junction temperature: -40°C to $+150^{\circ}\text{C}$, T_J
- Input voltage range:
 - Legacy chip: 5.5V to 42V (45V absolute max)
 - New chip: 3.0V to 40V (42V absolute max)
- Maximum output current: 500mA (new chip)
- Output voltage accuracy:
 - Legacy chip: $\pm 2.0\%$ (across line, load, and temperature)
 - New chip: $\pm 1.15\%$ (across line, load, and temperature)
- Low dropout voltage:
 - Legacy chip: 500mV (max) at 300mA
 - New chip: 400mV (max) at 315mA
- Low quiescent current:
 - Legacy chip: 100 μA (typ) at $I_{\text{OUT}} = 1\text{mA}$
 - New chip: 17 μA (typ) at light loads
- Excellent line transient response (new chip):
 - $\pm 2\%$ V_{OUT} deviation during cold-crank
 - $\pm 2\%$ V_{OUT} deviation ($1\text{V}/\mu\text{s}$ V_{IN} slew rate)
- Stable with a 2.2 μF or larger capacitor (new chip)
- Reverse-polarity protection (legacy chip)
- Packages:
 - 3-pin TO-252 (KVU)
 - 3-pin DPAK/TO-263 (KTT)
 - 20-pin HTSSOP (PWP) (legacy chip)

2 Applications

- [Reconfigurable instrument clusters](#)
- [Body control modules \(BCM\)](#)
- Always-on battery-connected applications:
 - [Automotive gateways](#)
 - [Remote keyless entries \(RKE\)](#)

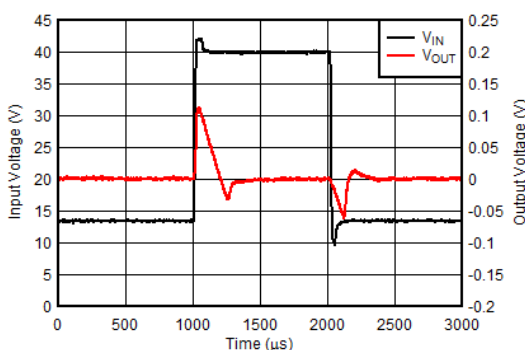

**Line Transient Response ($3\text{V}/\mu\text{s}$ V_{IN} Slew Rate)
(New Chip)**

3 Description

The TL720M05-Q1 is a low-dropout linear regulator designed to connect to the battery in automotive applications. The device has an input voltage range extending to 40V (new chip). This range allows the device to withstand transients (such as load dumps) that are anticipated in automotive systems. With only a 17 μA quiescent current at light loads, the device is designed for powering always-on components. Examples of such components are microcontrollers (MCUs) and controller area network (CAN) transceivers in standby systems.

The device (new chip) has a state-of-the-art transient response that allows the output to quickly react to changes in load or line. For example, during cold-crank conditions. Additionally, the device has a novel architecture that minimizes output overshoot when recovering from dropout. During normal operation, the device has a tight DC accuracy of $\pm 1.15\%$ over line, load, and temperature (new chip).

The device also incorporates a number of internal circuits for protection against overload and overtemperature. The legacy chip also provides protection against reverse polarity.

The TL720M05-Q1 is available in thermally conductive packaging to allow the device to efficiently transfer heat to the circuit board.

Package Information

PART NUMBER	PACKAGE ⁽¹⁾	PACKAGE SIZE ⁽²⁾
TL720M05-Q1	KTT (TO-263, 3)	10.16mm × 15.24mm
	KVU (TO-252, 3)	6.6mm × 10.11mm
	PWP (HTSSOP, 20) (legacy chip)	6.5mm × 6.4mm

- (1) For more information, see the [Mechanical, Packaging, and Orderable Information](#).
- (2) The package size (length × width) is a nominal value and includes pins, where applicable.

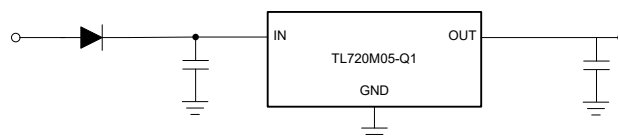

Typical Application Schematic (New Chip)



Table of Contents

1 Features	1	8 Application and Implementation	19
2 Applications	1	8.1 Application Information.....	19
3 Description	1	8.2 Typical Application.....	23
4 Pin Configuration and Functions	3	8.3 Power Supply Recommendations.....	25
5 Specifications	4	8.4 Layout.....	25
5.1 Absolute Maximum Ratings.....	4	9 Device and Documentation Support	27
5.2 ESD Ratings.....	4	9.1 Device Support.....	27
5.3 Recommended Operating Conditions.....	4	9.2 Documentation Support.....	27
5.4 Thermal Information.....	5	9.3 Receiving Notification of Documentation Updates....	27
5.5 Electrical Characteristics.....	5	9.4 Support Resources.....	27
5.6 Typical Characteristics.....	7	9.5 Trademarks.....	27
6 Parameter Measurement Information	15	9.6 Electrostatic Discharge Caution.....	27
7 Detailed Description	16	9.7 Glossary.....	27
7.1 Overview.....	16	10 Revision History	28
7.2 Functional Block Diagrams.....	16	11 Mechanical, Packaging, and Orderable Information	28
7.3 Feature Description.....	17		
7.4 Device Functional Modes.....	18		

4 Pin Configuration and Functions

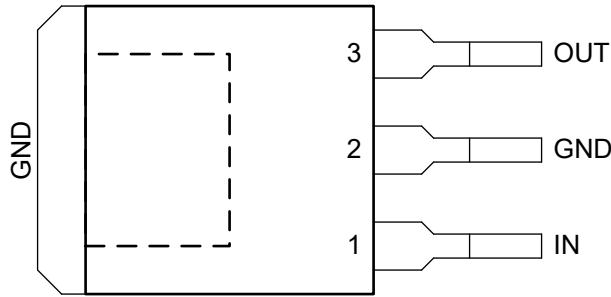

Figure 4-1. KTT Package, 3-Pin TO-263 (Top View)

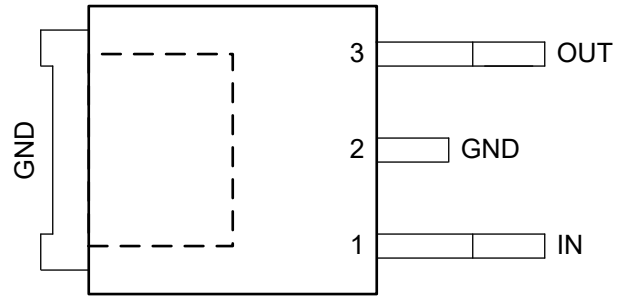

Figure 4-2. KVV Package, 3-Pin TO-252 (Top View)

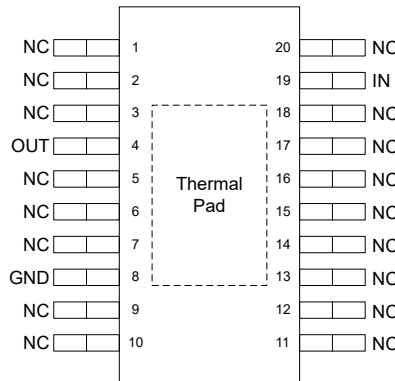

Figure 4-3. PWP Package⁽¹⁾, 20-Pin HTSSOP With PowerPAD (Top View)

Table 4-1. Pin Functions

NAME	PIN			TYPE ⁽²⁾	DESCRIPTION
	TO-263	TO-252	HTSSOP (Legacy Chip)		
GND	2	2	8	O	Ground. Internally connected to heat sink.
IN	1	1	19	I	Input power-supply voltage pin. For best transient response and to minimize input impedance, use the recommended value or larger ceramic capacitor from IN to ground. See the Recommended Operating Conditions table and the Input and Output Capacitor Selection section. Place the input capacitor as close to the input of the device as possible.
NC	—	—	1-3, 5-7, 9-18, 20	—	Not connected.
OUT	3	3	4	O	Regulated output voltage pin. A capacitor is required from OUT to ground for stability. For best transient response, use the nominal recommended value or larger ceramic capacitor from OUT to ground. See the Recommended Operating Conditions table and the Input and Output Capacitor Selection section. Place the output capacitor as close to output of the device as possible.

(1) NC = No internal connection.

(2) I = input, O = output.

5 Specifications

5.1 Absolute Maximum Ratings

over operating free-air temperature range (unless otherwise noted)⁽¹⁾

		MIN	MAX	UNIT
V _{IN}	Supply input voltage (for legacy chip)	-42	45	V
	Supply input voltage (for new chip)	-0.3	42	
V _{OUT}	Regulated output voltage (for legacy chip)	-1.0	40	
	Regulated output voltage (for new chip)	-0.3	V _{IN} + 0.3 V ⁽²⁾	
Current	Maximum output	Internally limited		A
Temperature	Operating junction, T _J	-40	150	°C
	Storage, T _{stg}	-65	150	

- (1) Stresses beyond those listed under *absolute maximum ratings* may cause permanent damage to the device. These are stress ratings only and functional operation of the device at these or any other conditions beyond those indicated under *recommended operating conditions* is not implied. Exposure to absolute-maximum-rated conditions for extended periods may affect device reliability.
- (2) The absolute maximum rating is V_{IN} + 0.3V or 20V, whichever is smaller

5.2 ESD Ratings

		VALUE (Legacy Chip)	VALUE (New Chip)	UNIT	
V _(ESD)	Electrostatic discharge	Human-body model (HBM), per AEC Q100-002 ⁽¹⁾		±2000	
		Charged-device model (CDM), per AEC Q100-011	All pins	N/A	±500
			Corner pins	N/A	±750

- (1) AEC Q100-002 indicates that HBM stressing shall be in accordance with the ANSI/ESDA/JEDEC JS-001 specification.

5.3 Recommended Operating Conditions

over operating free-air temperature range (unless otherwise noted)

		MIN	TYP	MAX	UNIT
V _{IN}	Supply input voltage (for legacy chip)	5.5		42	V
	Supply input voltage (for new chip)	3		40	
V _{OUT}	Output voltage		5.0		
I _{OUT}	Output current (for legacy chip)	0		400	
	Output current (for new chip)	0		500	
C _{OUT}	Output capacitor (for legacy chip) ⁽²⁾	22			μF
	Output capacitor (for new chip) ⁽²⁾	2.2		220	
C _{IN}	Input capacitor ⁽¹⁾		1		
ESR	Output capacitor ESR requirements (for legacy chip)	0.001		5	Ω
	Output capacitor ESR requirements (for new chip)	0.001		2	
T _J	Operating junction temperature	-40		150	°C

- (1) For robust EMI performance the minimum input capacitance is 500nF.
- (2) Effective output capacitance of 1μF minimum required for stability.

5.4 Thermal Information

THERMAL METRIC ^{(1) (2)}		TL720M05-Q1					UNIT
		KVU (TO-252-3)		KTT (TO-263-3)		PWP (HTSS OP-20)	
		Legacy Chip	New Chip	Legacy Chip	New Chip	Legacy Chip	
R _{θJA}	Junction-to-ambient thermal resistance	45.3	30	34.2	22.6	39.3	°C/W
R _{θJC(top)}	Junction-to-case (top) thermal resistance	36.8	39.5	38.2	6.0	22.7	°C/W
R _{θJB}	Junction-to-board thermal resistance	30.8	8.6	44.9	30.9	19.1	°C/W
ψ _{JT}	Junction-to-top characterization parameter	2.8	2.6	6	2.0	0.6	°C/W
ψ _{JB}	Junction-to-board characterization parameter	30.2	8.6	44.5	3.4	18.9	°C/W
R _{θJC(bot)}	Junction-to-case (bottom) thermal resistance	0.7	1.3	0.8	5.8	1.5	°C/W

- (1) The thermal data is based on the JEDEC standard high K profile, JESD 51-7. Two-signal, two-plane, four-layer board with 2-oz. copper. The copper pad is soldered to the thermal land pattern. Also, correct attachment procedure must be incorporated.
- (2) For more information about traditional and new thermal metrics, see the [Semiconductor and IC Package Thermal Metrics](#) application report.

5.5 Electrical Characteristics

specified at T_J = –40°C to +150°C, V_{IN} = 13.5V, I_{OUT} = 0mA, C_{OUT} = 2.2μF, 1mΩ < C_{OUT} ESR < 2Ω, and C_{IN} = 1μF (unless otherwise noted); typical values are at T_J = 25°C.

PARAMETER		Test Conditions	MIN	TYP	MAX	UNIT
V _{OUT}	Regulated output (for legacy chip)	V _{IN} = 6V to 28V, I _{OUT} = 5mA to 400mA	4.9	5.0	5.1	V
		V _{IN} = 6V to 40V, I _{OUT} = 5mA to 400mA	4.9	5.0	5.1	
	Regulated output (for new chip)	V _{IN} = V _{OUT} + 1V to 40V, I _{OUT} = 100μA to 450mA, T _J = 25°C ⁽¹⁾	–0.85		0.85	%
		V _{IN} = V _{OUT} + 1V to 40V, I _{OUT} = 100μA to 500mA, T _J = 25°C ⁽¹⁾	–0.85		0.85	
		V _{IN} = V _{OUT} + 1V to 40V, I _{OUT} = 100μA to 450mA ⁽¹⁾	–1.15		1.15	
	V _{IN} = V _{OUT} + 1V to 40V, I _{OUT} = 100μA to 500mA ⁽¹⁾	–1.15		1.15		
ΔV _{OUT(ΔI_{OUT})}	Load regulation (for legacy chip)	I _{OUT} = 5mA to 400mA		15	30	mV
	Load regulation (for new chip)	V _{IN} = V _{OUT} + 1V, I _{OUT} = 100μA to 450mA			0.425	
ΔV _{OUT(ΔV_{IN})}	Line regulation (for legacy chip)	V _{IN} = 8V to 32V, I _{OUT} = 5mA	–15	5	15	mV
	Line regulation (for new chip)	V _{IN} = V _{OUT} + 1V to 40V, I _{OUT} = 100μA			0.2	
ΔV _{OUT}	Load transient response settling time (for new chip) ⁽²⁾	t _R = t _F = 1μs; C _{OUT} = 10μF			100	μs
ΔV _{OUT}	Load transient response overshoot, undershoot (for new chip) ⁽²⁾	t _R = t _F = 1μs; C _{OUT} = 10μF	I _{OUT} = 150mA to 350mA	–2%		%V _{OUT}
			I _{OUT} = 350mA to 150mA		10%	
			I _{OUT} = 0mA to 500mA	–10%		
I _Q	Quiescent current (for legacy chip) I _Q = I _{IN} – I _{OUT}	I _{OUT} = 1mA	T _J = 25°C	100	220	μA
			T _J ≤ 85°C	100	220	
		I _{OUT} = 250mA		5	10	mA
	I _{OUT} = 400mA		12	22		
	Quiescent current (for new chip)	V _{IN} = V _{OUT} + 1V to 40V, I _{OUT} = 0mA, T _J = 25°C ⁽³⁾		17	21	μA
V _{IN} = V _{OUT} + 1V to 40V, I _{OUT} = 0mA ⁽³⁾				26		
	I _{OUT} = 500μA			35		
V _{DO}	Dropout voltage (for legacy chip)	I _{OUT} = 300mA		250	500	mV
	Dropout voltage (for new chip)	I _{OUT} ≤ 1mA, V _{IN} = V _{OUT(NOM)} × 0.95			46	
		I _{OUT} = 315mA, V _{IN} = V _{OUT(NOM)}		275	400	
		I _{OUT} = 450mA, V _{IN} = V _{OUT(NOM)}		360	525	
	I _{OUT} = 500mA, V _{IN} = V _{OUT(NOM)}		390	575		
V _{UVLO(RISING)}	Rising input supply UVLO (for new chip)	V _{IN} rising	2.6	2.7	2.82	V
V _{UVLO(FALLING)}	Falling input supply UVLO (for new chip)	V _{IN} falling	2.38	2.5	2.6	V

5.5 Electrical Characteristics (continued)

specified at $T_J = -40^\circ\text{C}$ to $+150^\circ\text{C}$, $V_{IN} = 13.5\text{V}$, $I_{OUT} = 0\text{mA}$, $C_{OUT} = 2.2\mu\text{F}$, $1\text{m}\Omega < C_{OUT} \text{ ESR} < 2\Omega$, and $C_{IN} = 1\mu\text{F}$ (unless otherwise noted); typical values are at $T_J = 25^\circ\text{C}$.

PARAMETER		Test Conditions	MIN	TYP	MAX	UNIT
$V_{UVLO(HYST)}$	$V_{UVLO(IN)}$ hysteresis (for new chip)			230		mV
I_{CL}	Output current limit (for legacy chip)	$V_{IN} = V_{OUT} + 1\text{V}$, V_{OUT} short to 90% x $V_{OUT(NOM)}$	450	700	950	mA
	Output current limit (for new chip)	$V_{IN} = V_{OUT} + 1\text{V}$, V_{OUT} short to 90% x $V_{OUT(NOM)}$	540		780	
PSRR	Power-supply rejection ratio (for legacy chip)	$V_{IN} - V_{OUT} = 1\text{V}$, frequency = 100Hz, $V_r = 0.5V_{pp}$, $I_{OUT} = 450\text{mA}$		60		dB
	Power-supply rejection ratio (for new chip)	$V_{IN} - V_{OUT} = 1\text{V}$, frequency = 1kHz, $I_{OUT} = 450\text{mA}$		70		
T_J	Junction temperature		-40		150	$^\circ\text{C}$
$T_{SD(SHUTDOWN)}$	Junction shutdown temperature (for new chip)			175		
$T_{SD(HYST)}$	Hysteresis of thermal shutdown (for new chip)			20		
$\Delta V_{OUT}/\Delta T$	Temperature output voltage drift (for legacy chip)			0.5		mV/K

- (1) Power dissipation is limited to 2W for device production testing purposes. The power dissipation is potentially higher during normal operation. See the *Thermal Performance* section for more information on how much power the device can dissipate while maintaining a junction temperature below 150°C .
- (2) Specified by design.
- (3) For the adjustable output this is tested in unity gain and resistor current is not included.

5.6 Typical Characteristics

specified for new chip at $T_J = -40^\circ\text{C}$ to $+150^\circ\text{C}$, $V_{IN} = 13.5\text{V}$, $I_{OUT} = 100\mu\text{A}$, $C_{OUT} = 2.2\mu\text{F}$, $1\text{m}\Omega < C_{OUT} \text{ ESR} < 2\Omega$, and $C_{IN} = 1\mu\text{F}$ (unless otherwise noted)

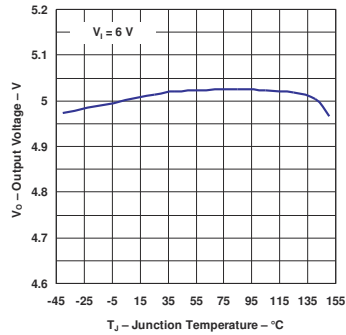

Figure 5-1. Output Voltage vs Junction Temperature (Legacy Chip)

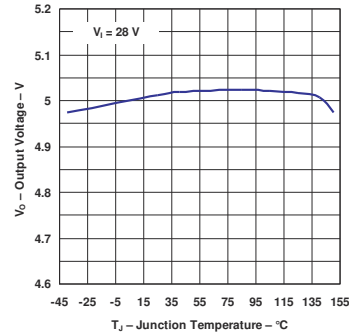

Figure 5-2. Output Voltage vs Junction Temperature (Legacy Chip)

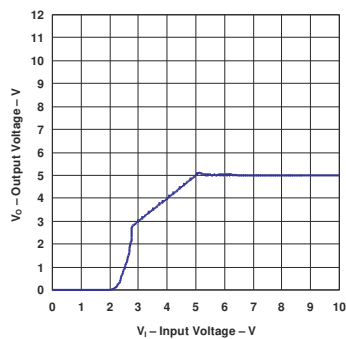

Figure 5-3. Output Voltage vs Input Voltage (Legacy Chip)

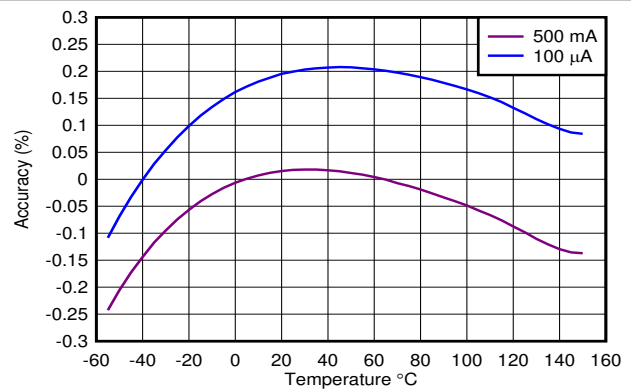

Figure 5-4. Output Accuracy vs Temperature (New Chip)

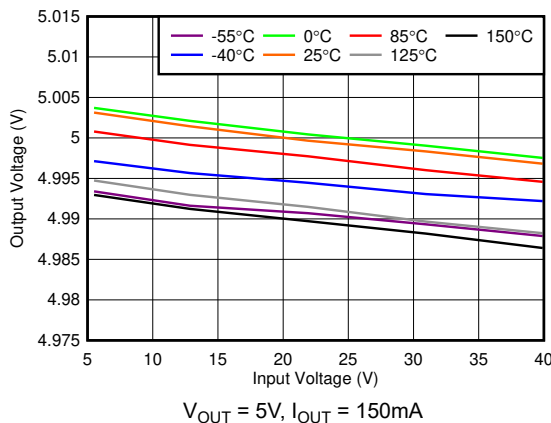

Figure 5-5. Line Regulation vs V_{IN} (New Chip)

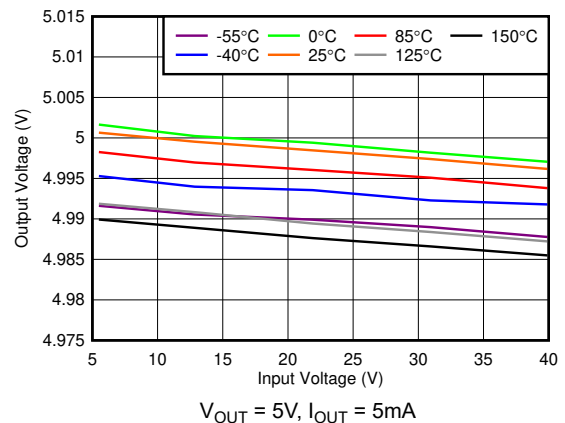
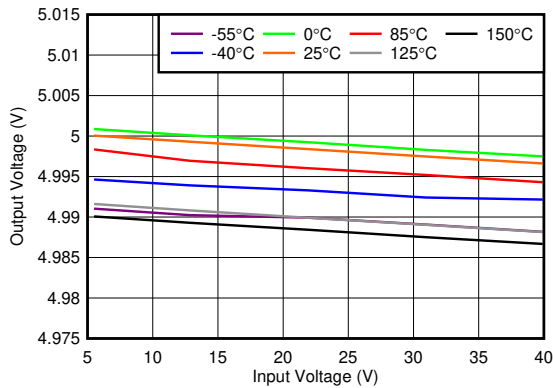

Figure 5-6. Line Regulation vs V_{IN} (New Chip)

5.6 Typical Characteristics (continued)

specified for new chip at $T_J = -40^\circ\text{C}$ to $+150^\circ\text{C}$, $V_{IN} = 13.5\text{V}$, $I_{OUT} = 100\mu\text{A}$, $C_{OUT} = 2.2\mu\text{F}$, $1\text{m}\Omega < C_{OUT} \text{ ESR} < 2\Omega$, and $C_{IN} = 1\mu\text{F}$ (unless otherwise noted)



$V_{OUT} = 5\text{V}$, $I_{OUT} = 1\text{mA}$

Figure 5-7. Line Regulation vs V_{IN} (New Chip)

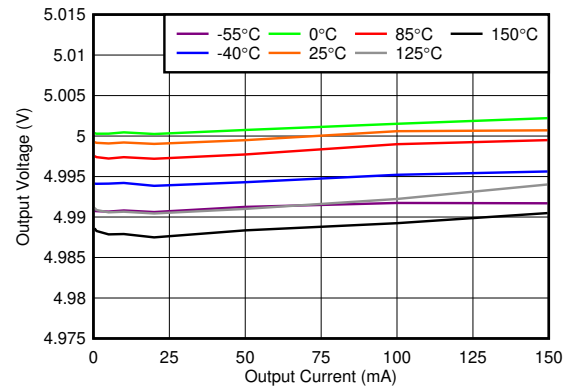

$V_{OUT} = 5\text{V}$

Figure 5-8. Load Regulation vs I_{OUT} (New Chip)

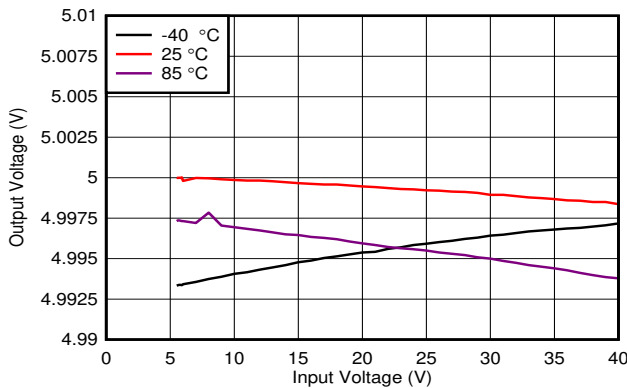

$C_{OUT} = 10\mu\text{F}$, $V_{OUT} = 5\text{V}$

Figure 5-9. Line Regulation at 50mA (New Chip)

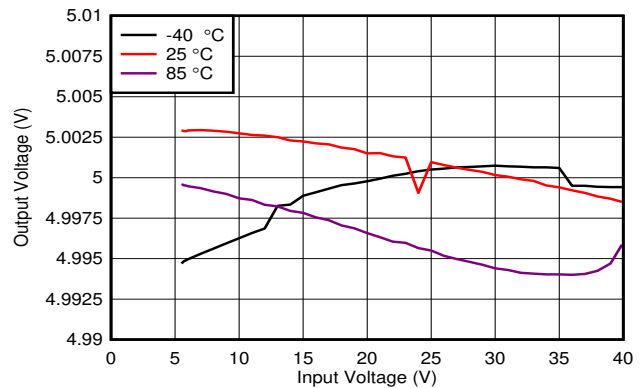

$C_{OUT} = 10\mu\text{F}$, $V_{OUT} = 5\text{V}$

Figure 5-10. Line Regulation at 100mA (New Chip)

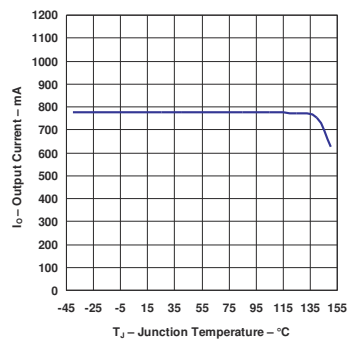

Figure 5-11. Output Current vs Junction Temperature (Legacy Chip)

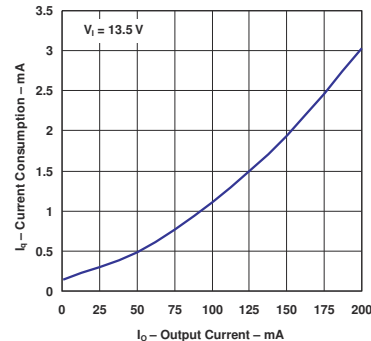

Figure 5-12. Current Consumption vs Output Current (Legacy Chip)

5.6 Typical Characteristics (continued)

specified for new chip at $T_J = -40^{\circ}\text{C}$ to $+150^{\circ}\text{C}$, $V_{IN} = 13.5\text{V}$, $I_{OUT} = 100\mu\text{A}$, $C_{OUT} = 2.2\mu\text{F}$, $1\text{m}\Omega < C_{OUT} \text{ ESR} < 2\Omega$, and $C_{IN} = 1\mu\text{F}$ (unless otherwise noted)

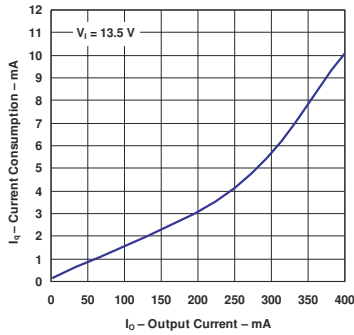

Figure 5-13. Current Consumption vs Output Current (Legacy Chip)

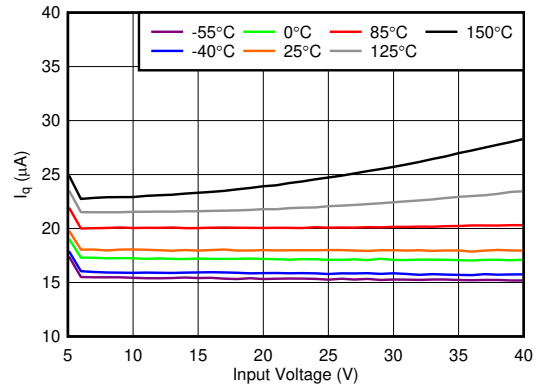

Figure 5-14. Quiescent Current (I_Q) vs V_{IN} (New Chip)

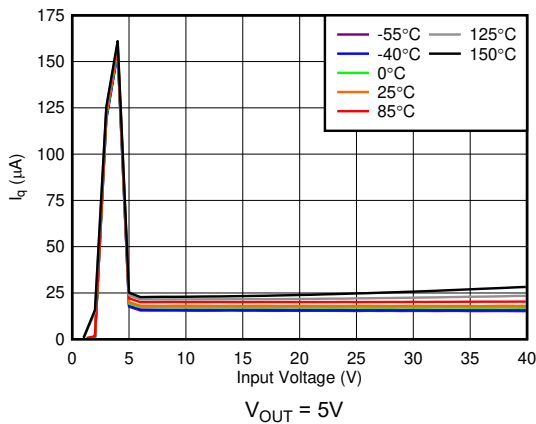

Figure 5-15. Quiescent Current (I_Q) vs V_{IN} (New Chip)

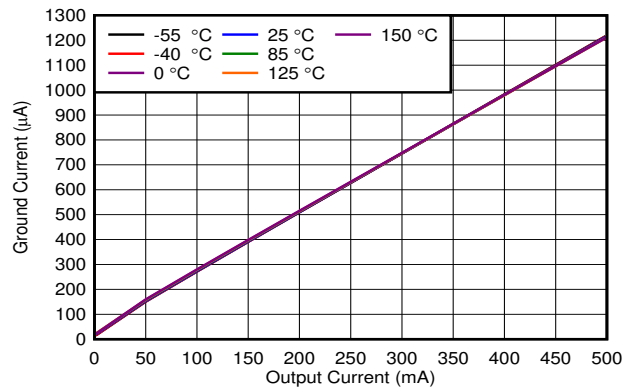

Figure 5-16. Ground Current (I_{GND}) vs I_{OUT} (New Chip)

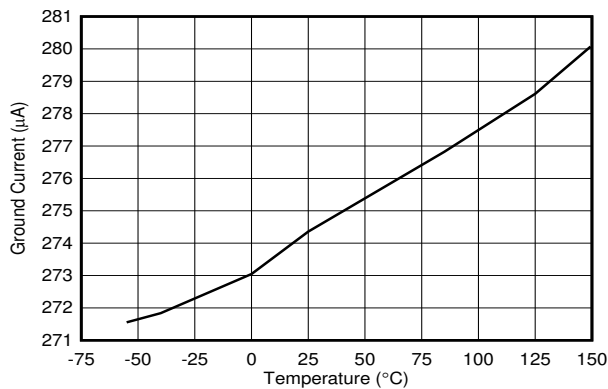

Figure 5-17. Ground Current at 100mA (New Chip)

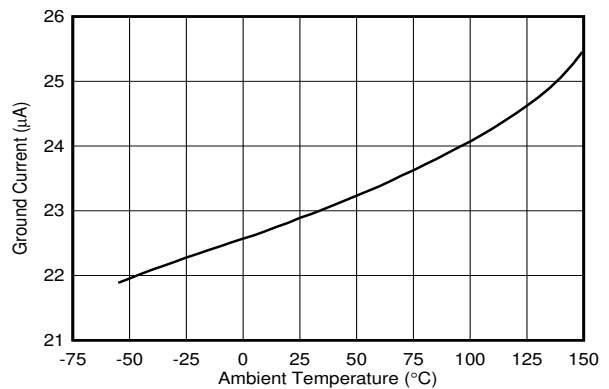

Figure 5-18. Ground Current at 500uA (New Chip)

5.6 Typical Characteristics (continued)

specified for new chip at $T_J = -40^\circ\text{C}$ to $+150^\circ\text{C}$, $V_{IN} = 13.5\text{V}$, $I_{OUT} = 100\mu\text{A}$, $C_{OUT} = 2.2\mu\text{F}$, $1\text{m}\Omega < C_{OUT} \text{ ESR} < 2\Omega$, and $C_{IN} = 1\mu\text{F}$ (unless otherwise noted)

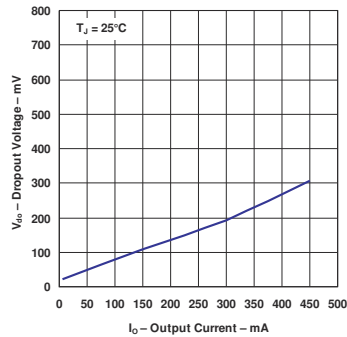

Figure 5-19. Dropout Voltage vs Output Current (Legacy Chip)

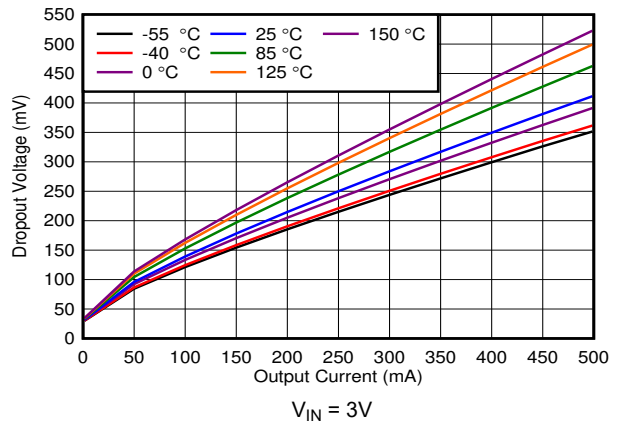

Figure 5-20. Dropout Voltage (V_{DO}) vs I_{OUT} (New Chip)

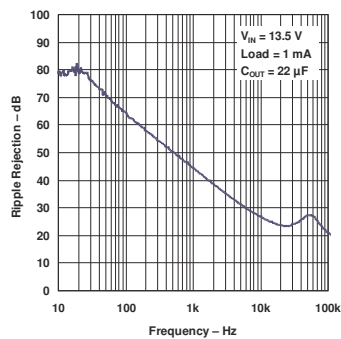

Figure 5-21. Power-Supply Ripple Rejection vs Frequency (Legacy Chip)

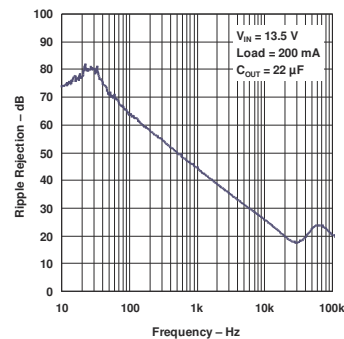

Figure 5-22. Power-Supply Ripple Rejection vs Frequency (Legacy Chip)

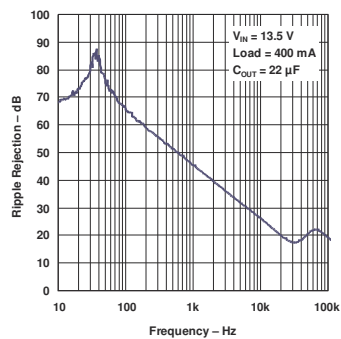

Figure 5-23. Power-Supply Ripple Rejection vs Frequency (Legacy Chip)

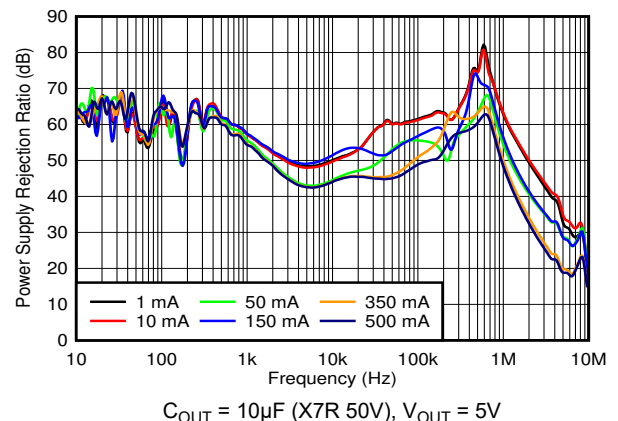

Figure 5-24. Power-Supply Ripple Rejection vs Frequency and I_{OUT} (New Chip)

5.6 Typical Characteristics (continued)

specified for new chip at $T_J = -40^{\circ}\text{C}$ to $+150^{\circ}\text{C}$, $V_{IN} = 13.5\text{V}$, $I_{OUT} = 100\mu\text{A}$, $C_{OUT} = 2.2\mu\text{F}$, $1\text{m}\Omega < C_{OUT} \text{ ESR} < 2\Omega$, and $C_{IN} = 1\mu\text{F}$ (unless otherwise noted)

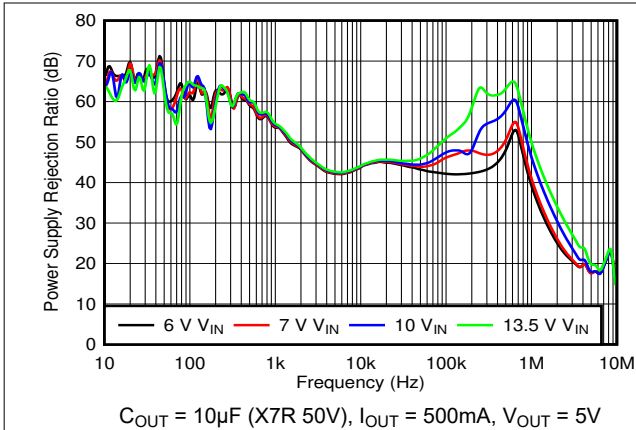

Figure 5-25. Power-Supply Ripple Rejection vs Frequency and V_{IN} (New Chip)

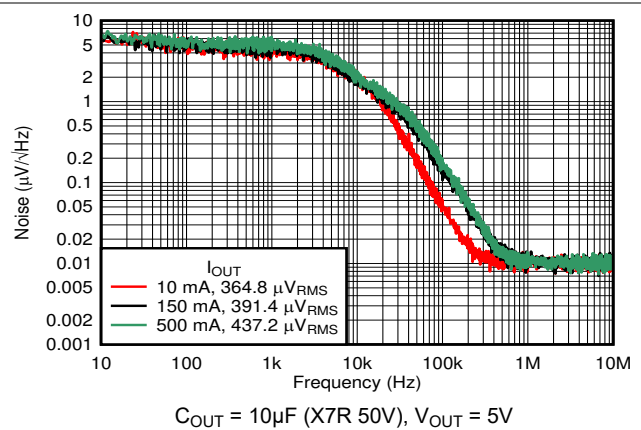

Figure 5-26. Noise vs Frequency (Legacy Chip)

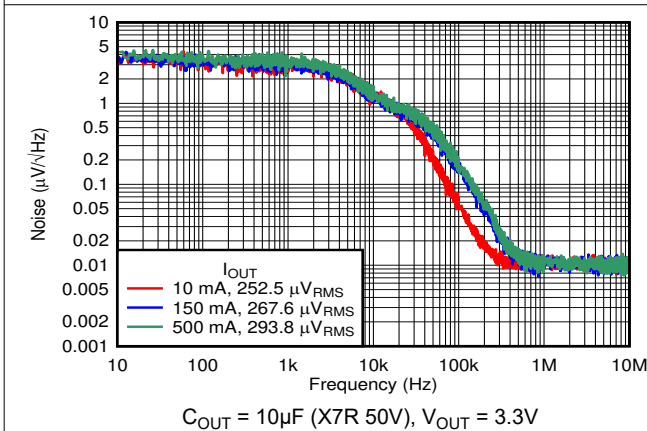

Figure 5-27. Noise vs Frequency (Legacy Chip)

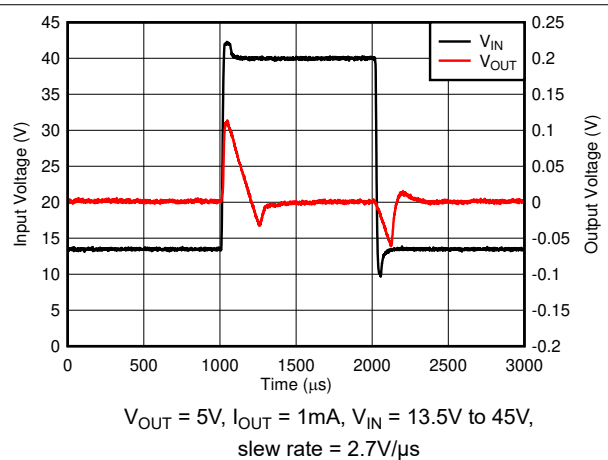

Figure 5-28. Line Transients (New Chip)

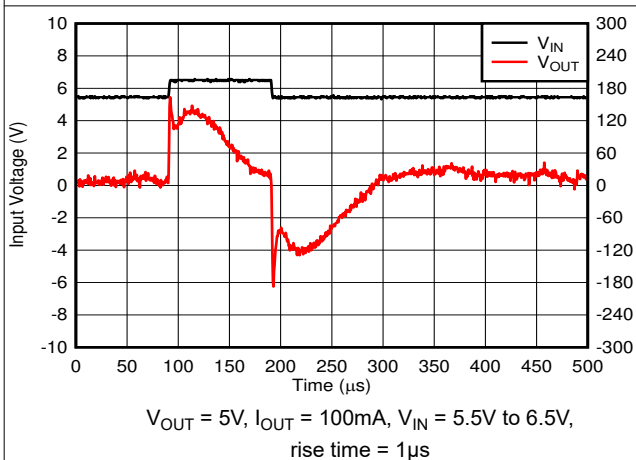

Figure 5-29. Line Transients (New Chip)

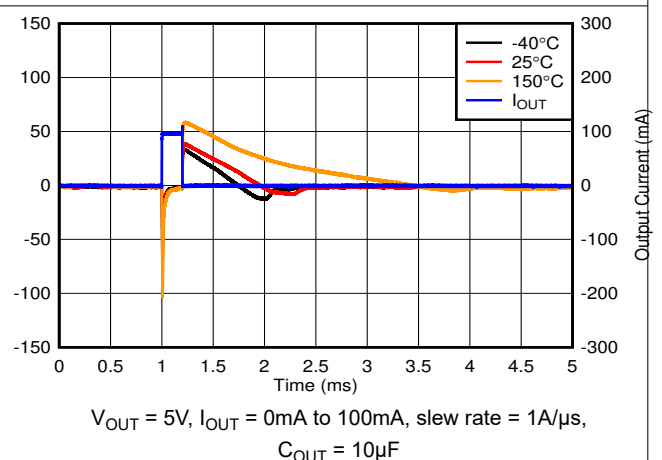
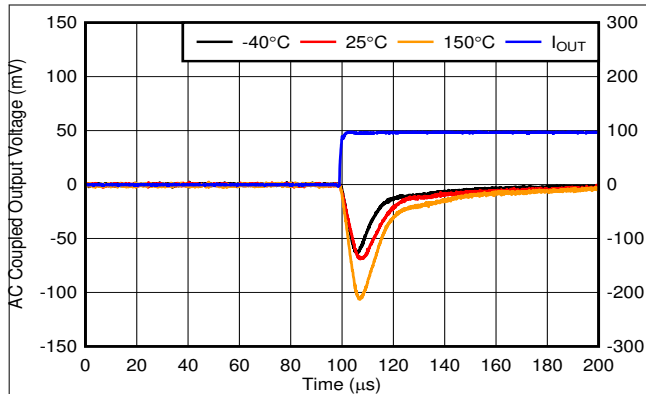

Figure 5-30. Load Transient, No Load to 100mA (New Chip)

5.6 Typical Characteristics (continued)

specified for new chip at $T_J = -40^\circ\text{C}$ to $+150^\circ\text{C}$, $V_{IN} = 13.5\text{V}$, $I_{OUT} = 100\mu\text{A}$, $C_{OUT} = 2.2\mu\text{F}$, $1\text{m}\Omega < C_{OUT} \text{ ESR} < 2\Omega$, and $C_{IN} = 1\mu\text{F}$ (unless otherwise noted)



$V_{OUT} = 5\text{V}$, $I_{OUT} = 0\text{mA}$ to 100mA , slew rate = $1\text{A}/\mu\text{s}$,
 $C_{OUT} = 10\mu\text{F}$

Figure 5-31. Load Transient, No Load to 100mA Rising Edge (New Chip)

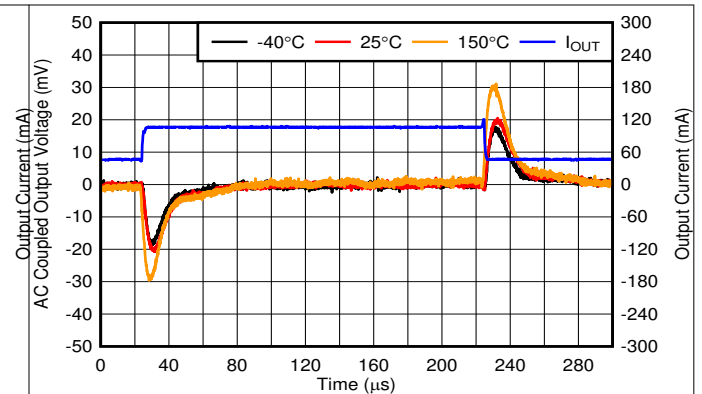

$V_{OUT} = 5\text{V}$, $I_{OUT} = 45\text{mA}$ to 105mA , slew rate = $0.1\text{A}/\mu\text{s}$,
 $C_{OUT} = 10\mu\text{F}$

Figure 5-32. Load Transient, 45mA to 105mA (New Chip)

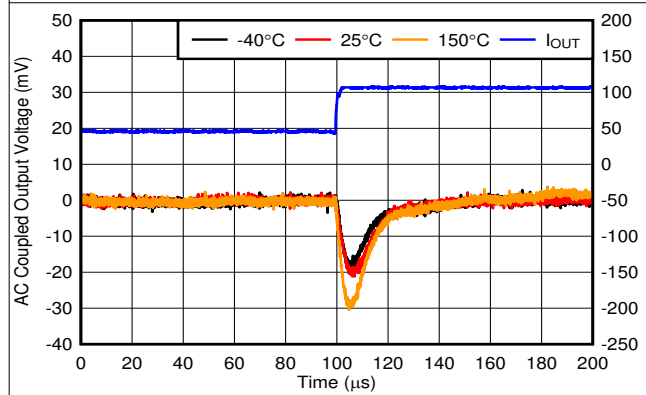

$V_{OUT} = 5\text{V}$, $I_{OUT} = 45\text{mA}$ to 105mA , slew rate = $0.1\text{A}/\mu\text{s}$,
 $C_{OUT} = 10\mu\text{F}$

Figure 5-33. Load Transient, 45mA to 105mA Rising Edge (New Chip)

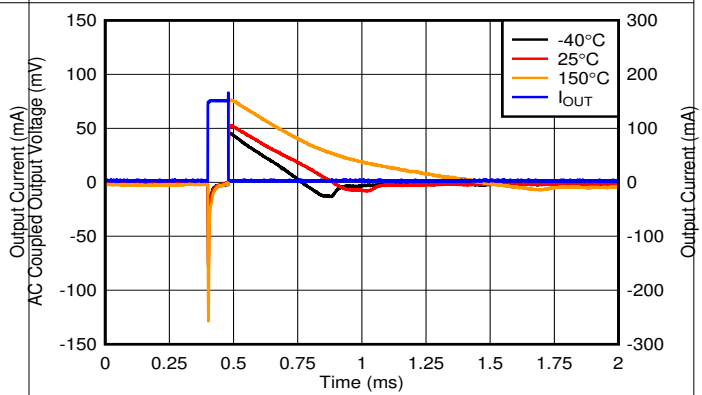

$V_{OUT} = 5\text{V}$, $I_{OUT} = 0\text{mA}$ to 150mA , slew rate = $1\text{A}/\mu\text{s}$,
 $C_{OUT} = 10\mu\text{F}$

Figure 5-34. Load Transient, No Load to 150mA (New Chip)

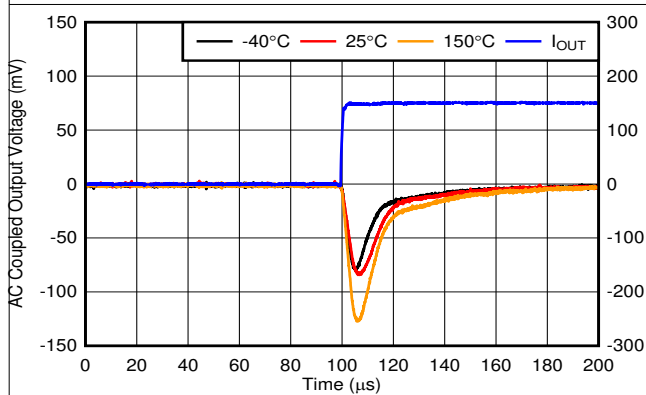

$V_{OUT} = 5\text{V}$, $I_{OUT} = 0\text{mA}$ to 150mA , slew rate = $1\text{A}/\mu\text{s}$,
 $C_{OUT} = 10\mu\text{F}$

Figure 5-35. Load Transient, No Load to 150mA Rising Edge (New Chip)

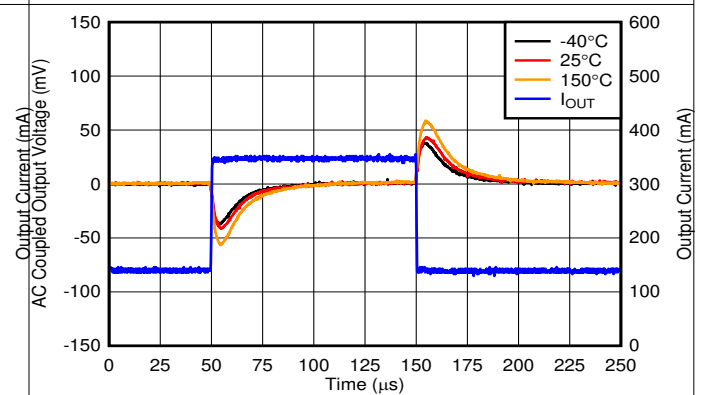

$V_{OUT} = 5\text{V}$, $I_{OUT} = 150\text{mA}$ to 350mA , slew rate = $0.1\text{A}/\mu\text{s}$,
 $C_{OUT} = 10\mu\text{F}$

Figure 5-36. Load Transient, 150mA to 350mA (New Chip)

5.6 Typical Characteristics (continued)

specified for new chip at $T_J = -40^\circ\text{C}$ to $+150^\circ\text{C}$, $V_{IN} = 13.5\text{V}$, $I_{OUT} = 100\mu\text{A}$, $C_{OUT} = 2.2\mu\text{F}$, $1\text{m}\Omega < C_{OUT} \text{ ESR} < 2\Omega$, and $C_{IN} = 1\mu\text{F}$ (unless otherwise noted)

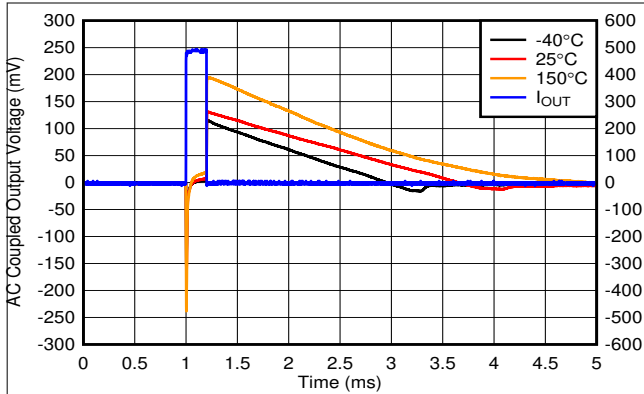

$V_{OUT} = 5\text{V}$, $I_{OUT} = 0\text{mA}$ to 500mA , slew rate = $1\text{A}/\mu\text{s}$,
 $C_{OUT} = 10\mu\text{F}$

Figure 5-37. Load Transient, No Load to 500mA (New Chip)

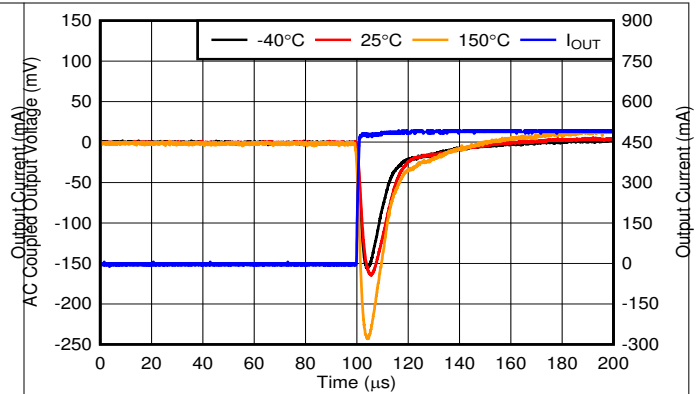

$V_{OUT} = 5\text{V}$, $I_{OUT} = 0\text{mA}$ to 500mA , slew rate = $1\text{A}/\mu\text{s}$,
 $C_{OUT} = 10\mu\text{F}$

Figure 5-38. Load Transient, No Load to 500mA Rising Edge (New Chip)

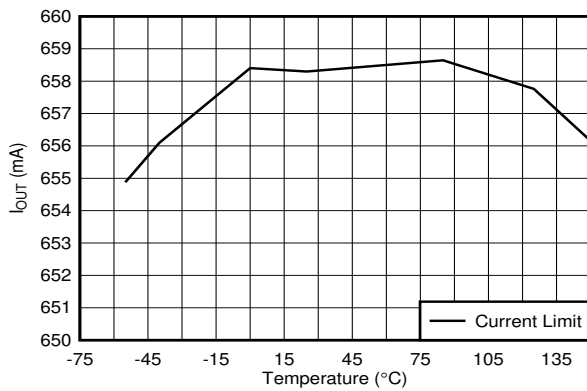

$V_{IN} = V_{OUT} + 1\text{V}$, $V_{OUT} = 90\% \times V_{OUT(NOM)}$

Figure 5-39. Output Current Limit vs Temperature (New Chip)

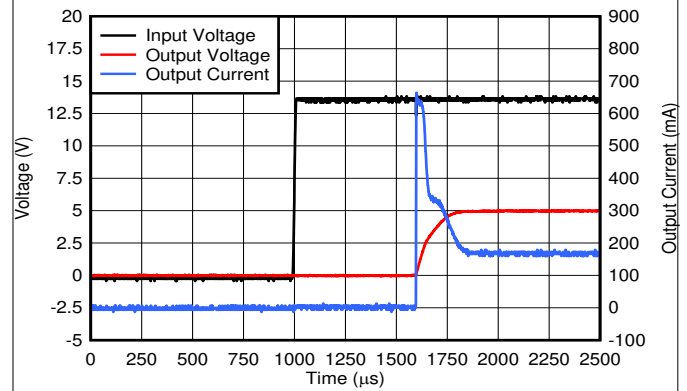

$V_{IN} = V_{OUT} + 1\text{V}$, $V_{OUT} = 90\% \times V_{OUT(NOM)}$

Figure 5-40. Start-Up Plot Inrush Current (New Chip)

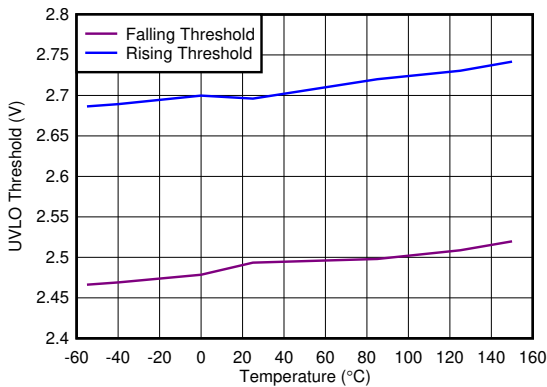

Figure 5-41. Undervoltage Lockout (UVLO) Threshold vs Temperature (New Chip)

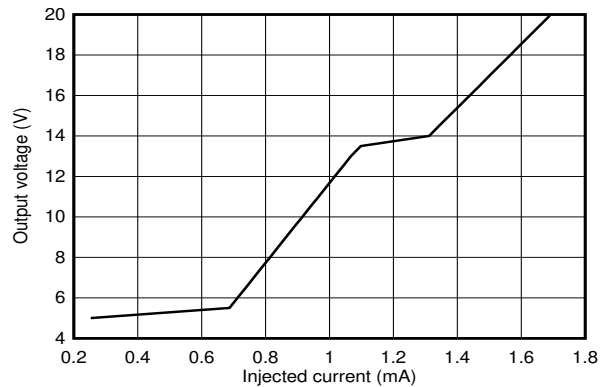

Figure 5-42. Output Voltage vs Injected Current (New Chip)

TL720M05-Q1

SGLS380I – SEPTEMBER 2008 – REVISED MAY 2024

5.6 Typical Characteristics (continued)

specified for new chip at $T_J = -40^{\circ}\text{C}$ to $+150^{\circ}\text{C}$, $V_{IN} = 13.5\text{V}$, $I_{OUT} = 100\mu\text{A}$, $C_{OUT} = 2.2\mu\text{F}$, $1\text{m}\Omega < C_{OUT} \text{ ESR} < 2\Omega$, and $C_{IN} = 1\mu\text{F}$ (unless otherwise noted)

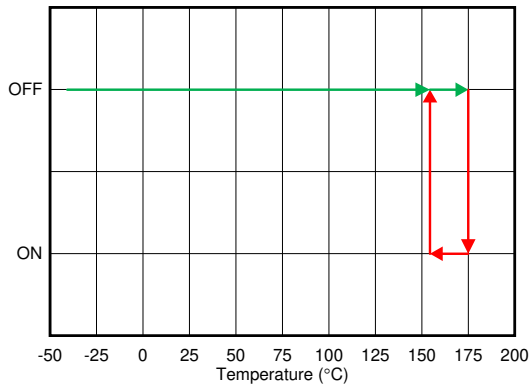

Figure 5-43. Thermal Shutdown (New Chip)

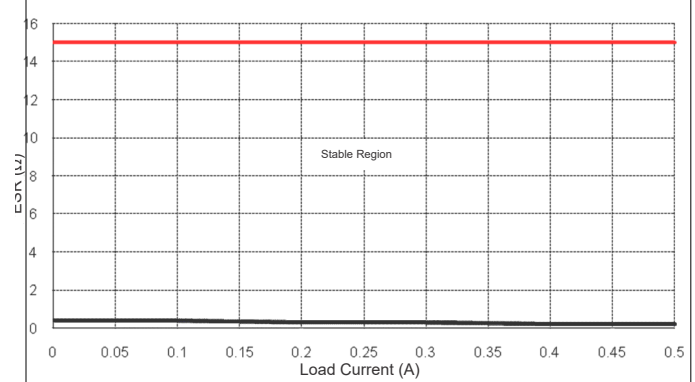

Figure 5-44. ESR Stability vs Load Current (Legacy Chip)

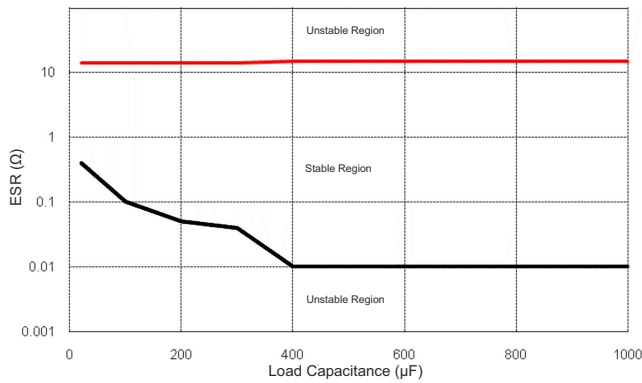

Figure 5-45. ESR Stability vs Load Capacitance (Legacy Chip)

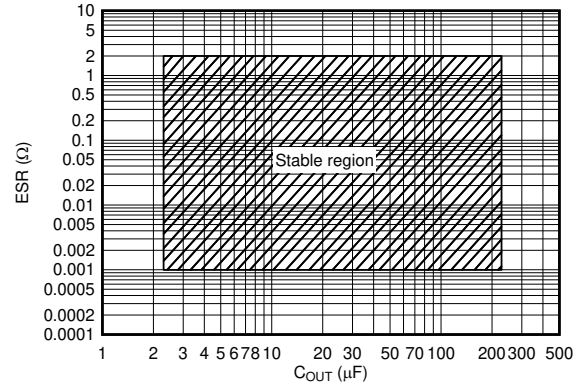

Figure 5-46. Stability, ESR vs C_{OUT} (New Chip)

6 Parameter Measurement Information

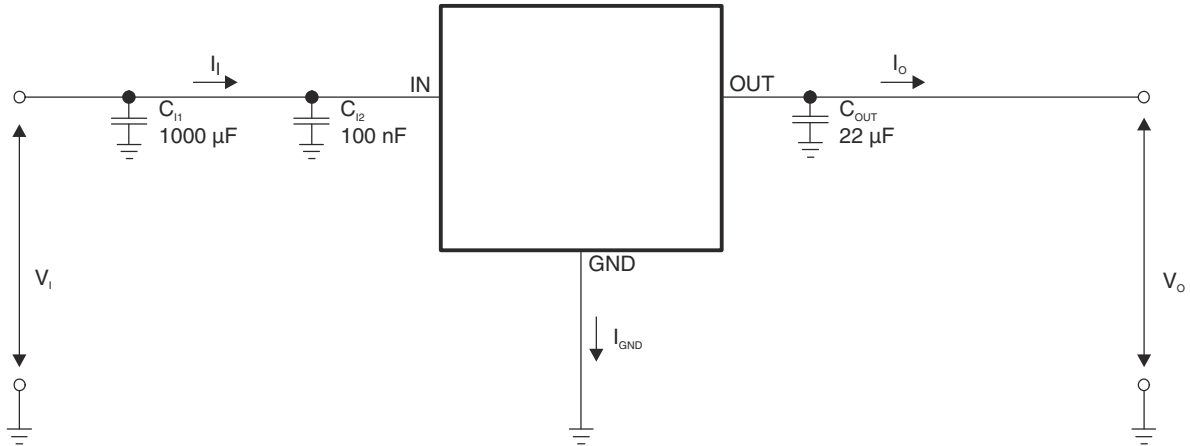

Figure 6-1. Test Circuit

7 Detailed Description

7.1 Overview

The TL720M05-Q1 is a low-dropout linear regulator (LDO) with improved transient performance that allows for quick response to changes in line or load conditions. The device also features a novel output overshoot reduction feature (new chip) that minimizes output overshoot during cold-crank conditions.

During normal operation, the device has a tight DC accuracy (new chip) of $\pm 1.15\%$ over line, load, and temperature. The increased accuracy allows for the powering of sensitive analog loads or sensors.

The TL720M05-Q1 has overtemperature protection and overcurrent protection during a load-short or fault condition on the output.

7.2 Functional Block Diagrams

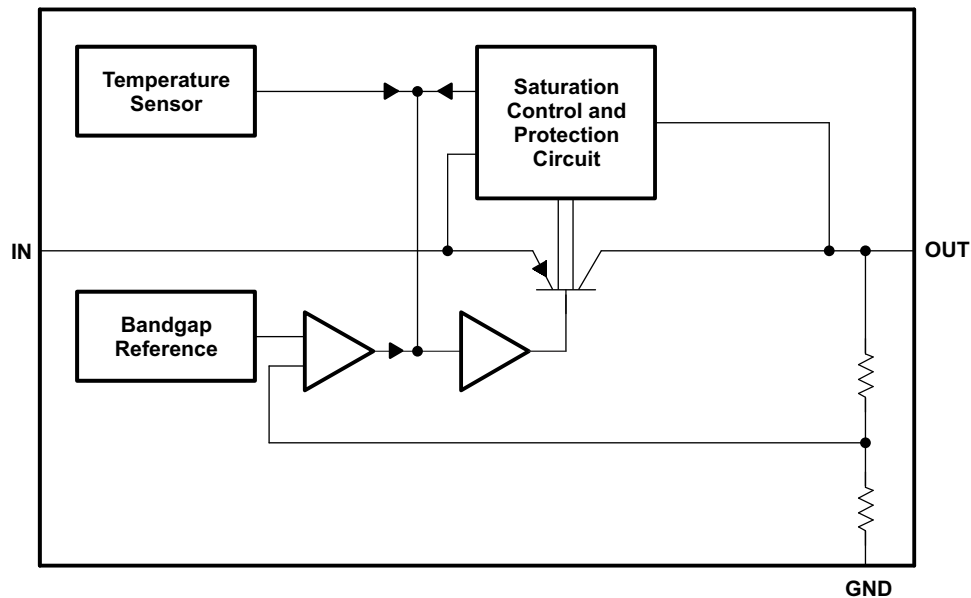

Figure 7-1. Functional Block Diagram (Legacy Chip)

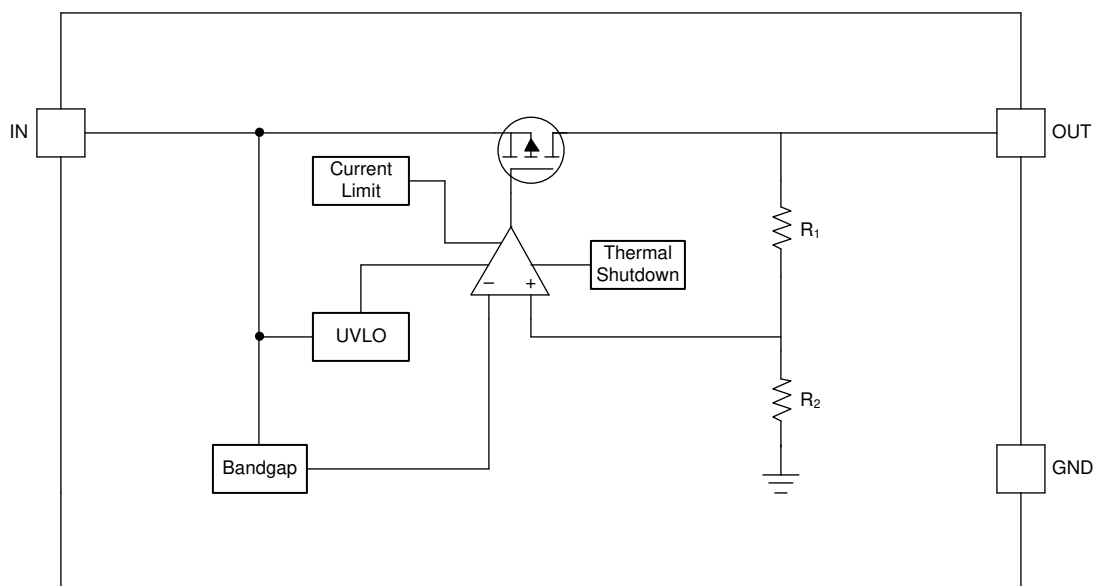

Figure 7-2. Functional Block Diagram (New Chip)

7.3 Feature Description

7.3.1 Undervoltage Lockout

The device has an independent undervoltage lockout (UVLO) circuit that monitors the input voltage. Thus, allowing a controlled and consistent turn on and off of the output voltage. To prevent the device from turning off if the input drops during turn on, the UVLO has hysteresis as specified in the [Electrical Characteristics](#) table.

7.3.2 Thermal Shutdown

The device contains a thermal shutdown protection circuit to disable the device when the junction temperature (T_J) of the pass transistor rises to $T_{SD(\text{shutdown})}$ (typical). Thermal shutdown hysteresis makes sure the device resets (turns on) when the temperature falls to $T_{SD(\text{reset})}$ (typical).

The thermal time-constant of the semiconductor die is fairly short. Thus the device cycles on and off when thermal shutdown is reached until power dissipation is reduced. Power dissipation during start-up is high from large $V_{IN} - V_{OUT}$ voltage drops across the device or from high inrush currents charging large output capacitors. Under some conditions, the thermal shutdown protection disables the device before start-up completes.

For reliable operation, limit the junction temperature to the maximum listed in the [Recommended Operating Conditions](#) table. Operation above this maximum temperature causes the device to exceed operational specifications. Although the device internal protection circuitry is designed to protect against thermal overload conditions, this circuitry is not intended to replace proper heat sinking. Continuously running the device into thermal shutdown or above the maximum recommended junction temperature reduces long-term reliability.

7.3.3 Current Limit

The device has an internal current limit circuit that protects the regulator during transient high-load current faults or shorting events. The current limit is a brick-wall scheme. In a high-load current fault, the brick-wall scheme limits the output current to the current limit (I_{CL}). I_{CL} is listed in the [Electrical Characteristics](#) table.

The output voltage is not regulated when the device is in current limit. When a current limit event occurs, the device begins to heat up because of the increase in power dissipation. When the device is in brick-wall current limit, the pass transistor dissipates power $[(V_{IN} - V_{OUT}) \times I_{CL}]$. If thermal shutdown is triggered, the device turns off. After the device cools down, the internal thermal shutdown circuit turns the device back on. If the output current fault condition continues, the device cycles between current limit and thermal shutdown. For more information on current limits, see the [Know Your Limits application note](#).

Figure 7-3 shows a diagram of the current limit.

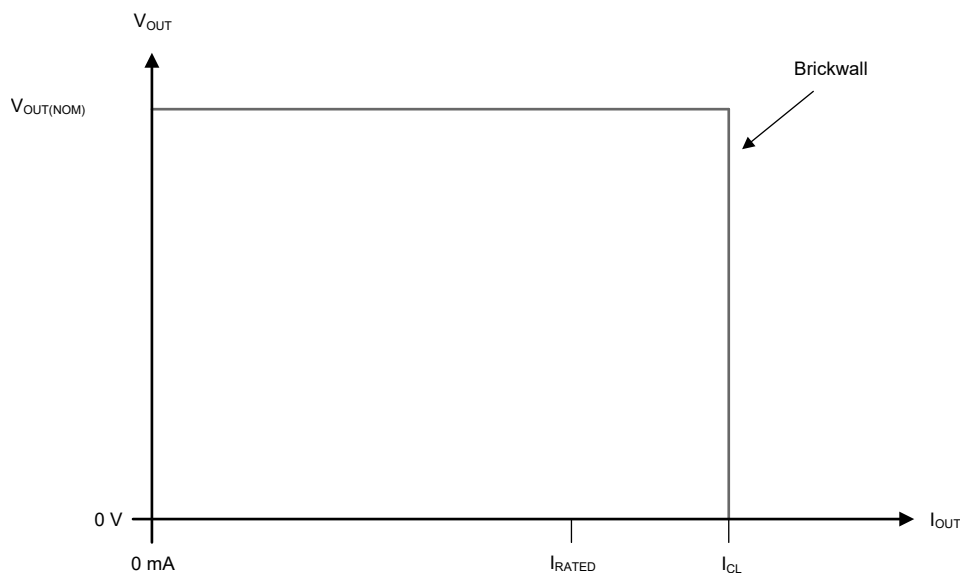

Figure 7-3. Current Limit

7.4 Device Functional Modes

Table 7-1 shows the conditions that lead to the different modes of operation. See the [Electrical Characteristics](#) table for parameter values.

Table 7-1. Device Functional Mode Comparison

OPERATING MODE	PARAMETER		
	V_{IN}	I_{OUT}	T_J
Normal operation	$V_{IN} > V_{OUT(nom)} + V_{DO}$ and $V_{IN} > V_{IN(min)}$	$I_{OUT} < I_{OUT(max)}$	$T_J < T_{SD(shutdown)}$
Dropout operation	$V_{IN(min)} < V_{IN} < V_{OUT(nom)} + V_{DO}$	$I_{OUT} < I_{OUT(max)}$	$T_J < T_{SD(shutdown)}$
Disabled (any true condition disables the device)	$V_{IN} < V_{UVLO}$	Not applicable	$T_J > T_{SD(shutdown)}$

7.4.1 Normal Operation

The device regulates to the nominal output voltage when the following conditions are met:

- The input voltage is greater than the nominal output voltage plus the dropout voltage ($V_{OUT(nom)} + V_{DO}$)
- The output current is less than the current limit ($I_{OUT} < I_{CL}$)
- The device junction temperature is less than the thermal shutdown temperature ($T_J < T_{SD}$)
- The enable voltage has previously exceeded the enable rising threshold voltage and has not yet decreased to less than the enable falling threshold

7.4.2 Dropout Operation

If the input voltage is lower than the nominal output voltage plus the specified dropout voltage, the device operates in dropout mode. In this mode, the output voltage tracks the input voltage. In this mode, the transient performance of the device becomes significantly degraded. During this mode, the pass transistor is in the ohmic or triode region, and acts as a switch. Line or load transients in dropout potentially result in large output voltage deviations.

When the device is in a steady dropout state, the pass transistor is driven fully on. This state is defined as when the device is in dropout, directly after being in a normal regulation state, but *not* during start up. Dropout occurs when $V_{IN} < V_{OUT(NOM)} + V_{DO}$. When the input voltage returns to a value $\geq V_{OUT(NOM)} + V_{DO}$, the output voltage potentially overshoots for a short period of time. $V_{OUT(NOM)}$ is the nominal output voltage and V_{DO} is the dropout voltage. During dropout exit, the device pulls the pass transistor back into the linear region.

7.4.3 Disabled

Shutdown the device output by forcing the input voltage below the UVLO falling threshold (see the [Electrical Characteristics](#) table). When disabled, the pass transistor is turned off and internal circuits are shutdown.

8 Application and Implementation

Note

Information in the following applications sections is not part of the TI component specification, and TI does not warrant its accuracy or completeness. TI's customers are responsible for determining suitability of components for their purposes, as well as validating and testing their design implementation to confirm system functionality.

8.1 Application Information

Based on the end-application, different values of external components are available. In some cases, an application requires a larger output capacitor during fast load steps to prevent a reset from occurring. Use a low-ESR ceramic capacitor with a dielectric of type X5R or X7R for better load transient response.

8.1.1 Input and Output Capacitor Selection

8.1.1.1 Legacy Chip Capacitor Selection

The input capacitor (C_{IN}) compensates for line fluctuation. Using a resistor of approximately 1Ω in series with C_{IN} dampens the oscillation of input inductivity and input capacitance. The output capacitor (C_{OUT}) stabilizes the regulation circuit. The output is stable at $C_{OUT} \geq 22\mu\text{F}$ and $\text{ESR} \leq 5\Omega$, which is within the operating temperature range.

8.1.1.2 New Chip Output Capacitor

The new chip version of the TL720M05-Q1 requires a $2.2\mu\text{F}$ or larger output capacitor ($1\mu\text{F}$ or larger capacitance) for stability. An equivalent series resistance (ESR) between 0.001Ω and 2Ω is also required. For best transient performance, use X5R- and X7R-type ceramic capacitors because these capacitors have minimal variation in value and ESR over temperature. When choosing a capacitor for a specific application, be mindful of the DC bias characteristics for the capacitor. Higher output voltages cause a significant derating of the capacitor. For best performance, the maximum recommended output capacitance is $220\mu\text{F}$.

8.1.1.3 New Chip Input Capacitor

Although an input capacitor is not required for stability, good analog design practice is to connect a capacitor from IN to GND. Some input supplies have a high impedance, thus placing the input capacitor on the input supply helps reduce the input impedance. This capacitor counteracts reactive input sources and improves transient response, input ripple, and PSRR. If the input supply is high impedance over a large range of frequencies, use several input capacitors in parallel to lower the impedance over frequency. Use a higher-value capacitor if large, fast, rise-time load transients are anticipated, or if the device is located several inches from the input power source.

8.1.2 Dropout Voltage

Dropout voltage (V_{DO}) is defined as $V_{IN} - V_{OUT}$ at the rated output current (I_{RATED}), where the pass transistor is fully on. V_{IN} is the input voltage, V_{OUT} is the output voltage, and I_{RATED} is the maximum I_{OUT} listed in the [Recommended Operating Conditions](#) table. At this operating point, the pass transistor is driven fully on. Dropout voltage indirectly specifies a minimum input voltage greater than the nominal programmed output voltage where the output voltage is expected to stay in regulation. If the input voltage falls to less than the nominal output regulation, then the output voltage falls as well.

For a CMOS regulator, the dropout voltage is determined by the drain-source, on-state resistance ($R_{DS(ON)}$) of the pass transistor. Therefore, if the linear regulator operates at less than the rated current, the dropout voltage for that current scales accordingly. The following equation calculates the $R_{DS(ON)}$ of the device.

$$R_{DS(ON)} = \frac{V_{DO}}{I_{RATED}} \quad (1)$$

8.1.3 Reverse Current

Excessive reverse current potentially damages this device. Reverse current flows through the intrinsic body diode of the pass transistor instead of the normal conducting channel. At high magnitudes, this current flow degrades the long-term reliability of the device.

Conditions where reverse current potentially occur are outlined in this section, all of which exceed the absolute maximum rating of $V_{OUT} \leq V_{IN} + 0.3V$.

- If the device has a large C_{OUT} and the input supply collapses with little or no load current
- The output is biased when the input supply is not established
- The output is biased above the input supply

If reverse current flow is expected in the application, use external protection to protect the device. Reverse current is not limited in the device, so external limiting is required if extended reverse voltage operation is anticipated.

8.1.4 Power Dissipation (P_D)

Circuit reliability requires consideration of the device power dissipation, location of the circuit on the PCB, and correct sizing of the thermal plane. Make sure the printed circuit board (PCB) area around the regulator has few or no other heat-generating devices that cause added thermal stress.

To first-order approximation, power dissipation in the regulator depends on the input-to-output voltage difference and load conditions. The following equation calculates power dissipation (P_D).

$$P_D = (V_{IN} - V_{OUT}) \times I_{OUT} \quad (2)$$

Note

Power dissipation is minimized, and therefore greater efficiency achieved, by correct selection of the system voltage rails. For the lowest power dissipation use the minimum input voltage required for correct output regulation.

For devices with a thermal pad, the primary heat conduction path for the device package is through the thermal pad to the PCB. Solder the thermal pad to a copper pad area under the device. Make sure this pad area contains an array of plated vias that conduct heat to additional copper planes for increased heat dissipation.

The maximum power dissipation determines the maximum allowable ambient temperature (T_A) for the device. Power dissipation and junction temperature are most often related by the $R_{\theta JA}$ of the combined PCB and device package and the ambient air temperature (T_A). $R_{\theta JA}$ is the junction-to-ambient thermal resistance. [Equation 3](#) calculates this relationship.

$$T_J = T_A + (R_{\theta JA} \times P_D) \quad (3)$$

Thermal resistance ($R_{\theta JA}$) is highly dependent on the heat-spreading capability built into the particular PCB design. Therefore, $R_{\theta JA}$ varies according to the total copper area, copper weight, and location of the planes. The junction-to-ambient thermal resistance listed in the [Thermal Information](#) table is determined by the JEDEC standard PCB and copper-spreading area. This resistance is used as a relative measure of package thermal performance.

8.1.4.1 Thermal Performance Versus Copper Area

The most used thermal resistance parameter $R_{\theta JA}$ is highly dependent on the heat-spreading capability built into the particular PCB design. Therefore, $R_{\theta JA}$ varies according to the total copper area, copper weight, and location of the planes. The $R_{\theta JA}$ recorded in the [Thermal Information](#) table is determined by the JEDEC standard (see [Figure 8-1](#)), PCB, and copper-spreading area. $R_{\theta JA}$ is only used as a relative measure of package thermal performance. For a well-designed thermal layout, $R_{\theta JA}$ is actually the sum of $R_{\theta JCbot}$ plus the thermal resistance contribution by the PCB copper. $R_{\theta JCbot}$ is the package junction-to-case (bottom) thermal resistance.

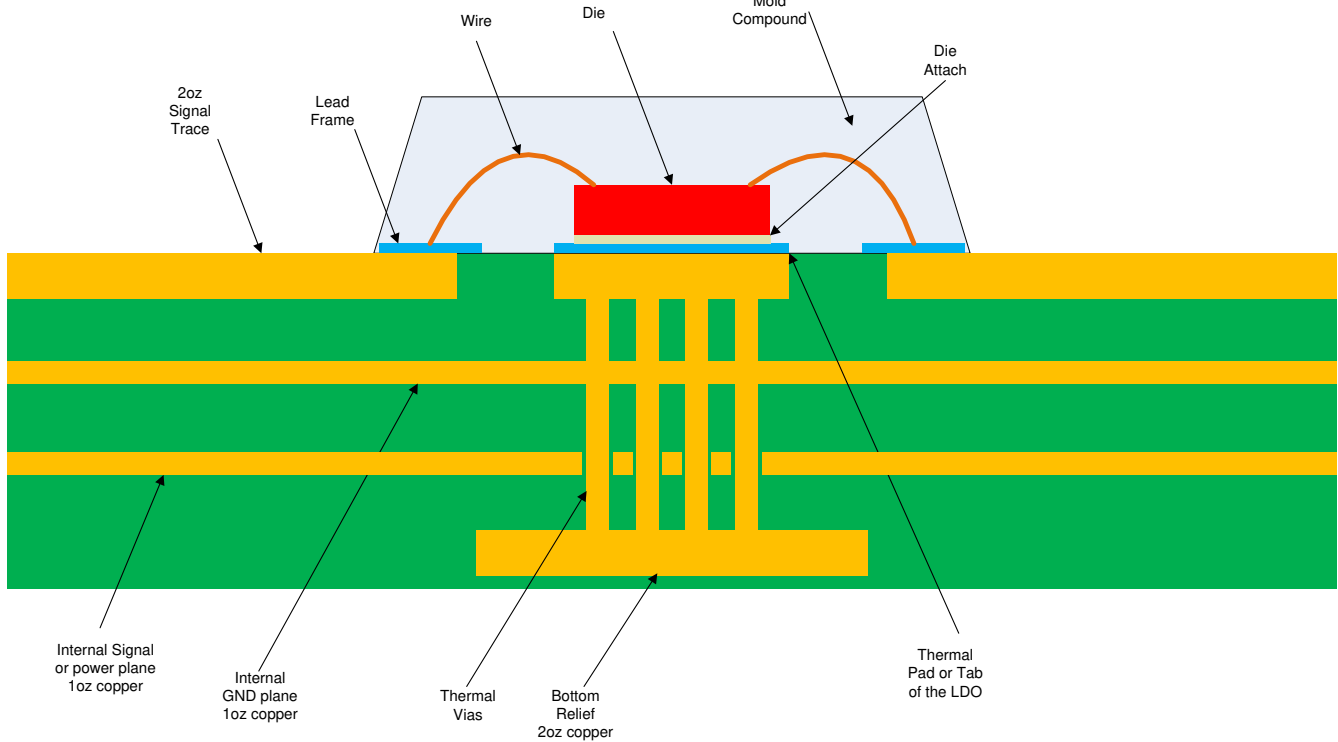

Figure 8-1. JEDEC Standard 2s2p PCB

Figure 8-2 and Figure 8-3 show the functions of $R_{\theta JA}$ and ψ_{JB} versus copper area and thickness. These plots are generated with a 101.6mm × 101.6mm × 1.6mm PCB of two and four layers. For the 4-layer board, inner planes use 1oz copper thickness. Outer layers are simulated with both 1oz and 2oz copper thickness. A 3×4 (KVU package) array of thermal vias with a 300μm drill diameter and 25μm copper plating is located beneath the device thermal pad. The thermal vias connect the top layer, the bottom layer and, in the case of the 4-layer board, the first inner GND plane. Each of the layers has a copper plane of equal area.

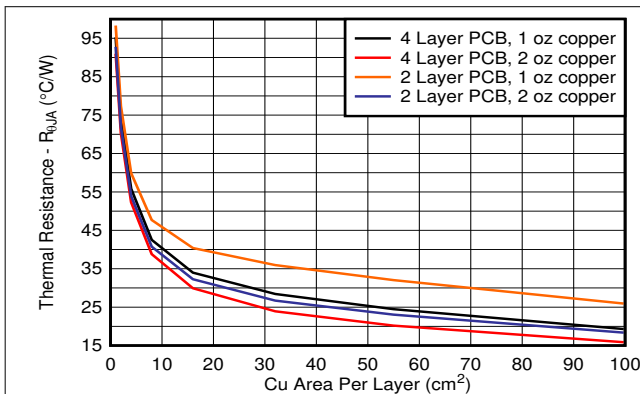

Figure 8-2. $R_{\theta JA}$ vs Copper Area (KVU Package)

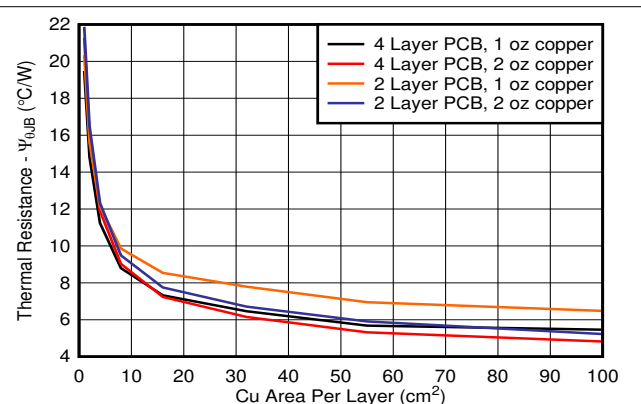

Figure 8-3. ψ_{JB} vs Copper Area (KVU Package)

8.1.4.2 Power Dissipation Versus Ambient Temperature

Figure 8-4 is based off of a JEDEC 51-7 4-layer, high-K board. Estimate the allowable power dissipation with the following equation. Improve thermal dissipation in the JEDEC high-K layout by adding top layer copper and increasing the number of thermal vias. See the [An empirical analysis of the impact of board layout on LDO thermal performance application note](#). If a good thermal layout is used, the allowable thermal dissipation is improved by up to 50%.

$$T_A + R_{\theta JA} \times P_D \leq 150 \text{ } ^\circ\text{C} \quad (4)$$

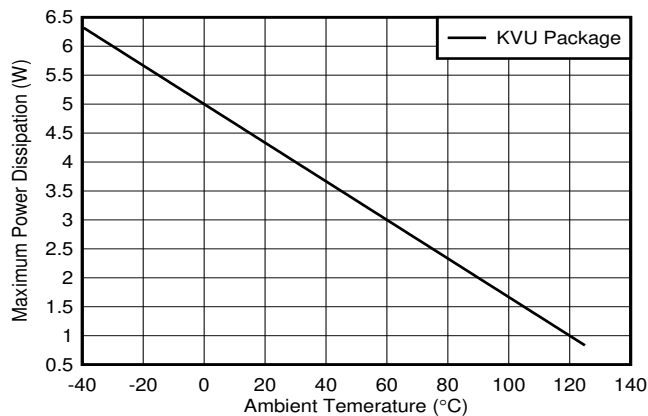

Figure 8-4. TL720M05-Q1 Allowable Power Dissipation

8.1.5 Estimating Junction Temperature

The JEDEC standard recommends using psi (Ψ) thermal metrics to estimate the junction temperatures of the linear regulator when in-circuit on a typical PCB board application. These metrics are not thermal resistance parameters and instead offer a practical and relative way to estimate junction temperature. These psi metrics are determined to be significantly independent of the copper area available for heat-spreading. The [Thermal Information](#) table lists the primary thermal metrics, which are the junction-to-top characterization parameter (ψ_{JT}) and junction-to-board characterization parameter (ψ_{JB}). These parameters provide two methods for calculating the junction temperature (T_J), as described in the following equations. Use the junction-to-top characterization parameter (ψ_{JT}) with the temperature at the center-top of device package (T_T) to calculate the junction temperature. Use the junction-to-board characterization parameter (ψ_{JB}) with the PCB surface temperature 1mm from the device package (T_B) to calculate the junction temperature.

$$T_J = T_T + \psi_{JT} \times P_D \quad (5)$$

where:

- P_D is the dissipated power
- T_T is the temperature at the center-top of the device package

$$T_J = T_B + \psi_{JB} \times P_D \quad (6)$$

where:

- T_B is the PCB surface temperature measured 1mm from the device package and centered on the package edge

For detailed information on the thermal metrics and how to use them, see the [Semiconductor and IC Package Thermal Metrics application note](#).

8.2 Typical Application

Figure 8-5 shows a typical application circuit for the TL720M05-Q1.

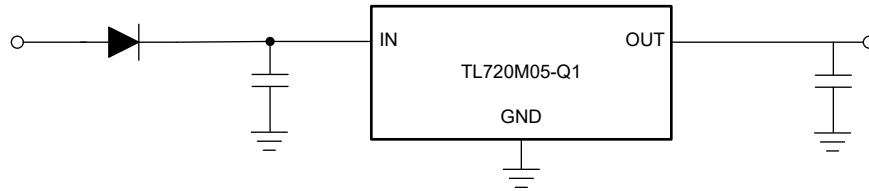

Figure 8-5. Typical Application Diagram (New Chip)

8.2.1 Design Requirements

Use the parameters listed in Table 8-1 for this design example.

Table 8-1. Design Parameters

DESIGN PARAMETER	EXAMPLE VALUE
Input voltage range	4V to 40V
Output voltage	5V
Output current rating	400mA
Output capacitor range	10 μ F to 200 μ F

8.2.2 Detailed Design Procedure

8.2.2.1 Input Capacitor

The device requires an input decoupling capacitor, the value of which depends on the application. The typical recommended value for the decoupling capacitor is 1 μ F. Make sure the voltage rating is greater than the maximum input voltage.

8.2.2.2 Output Capacitor

The device (new chip) requires an output capacitor to stabilize the output voltage. Make sure the capacitor value is between 2.2 μ F and 200 μ F and the ESR range is between 1m Ω and 2 Ω . For this design, use a low ESR, 10 μ F ceramic capacitor to improve transient performance.

8.2.3 Application Curves

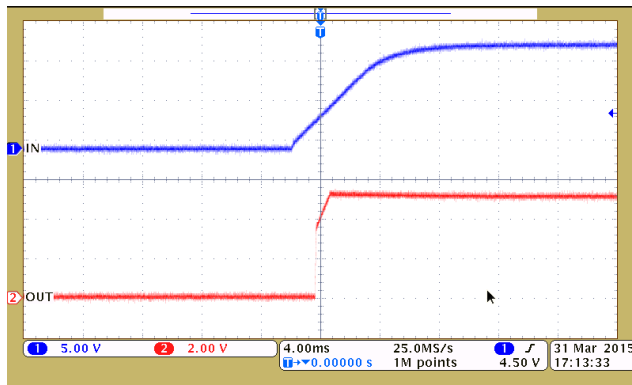

Channel 1: V_{IN}, channel 2: V_{OUT}

Figure 8-6. Power-Up Waveform (Load = 50mA) (Legacy Chip)

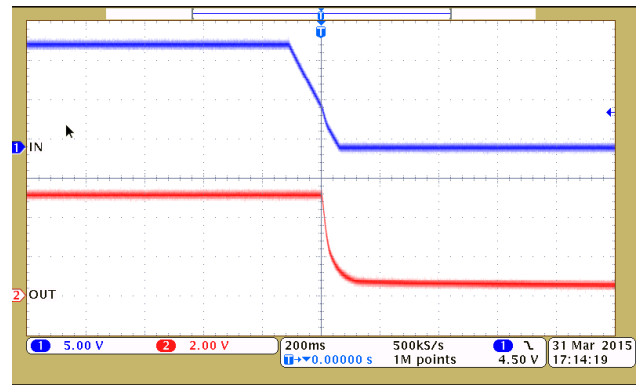

Channel 1: V_{IN}, channel 2: V_{OUT}

Figure 8-7. Power-Down Waveform (Load = 50mA) (Legacy Chip)

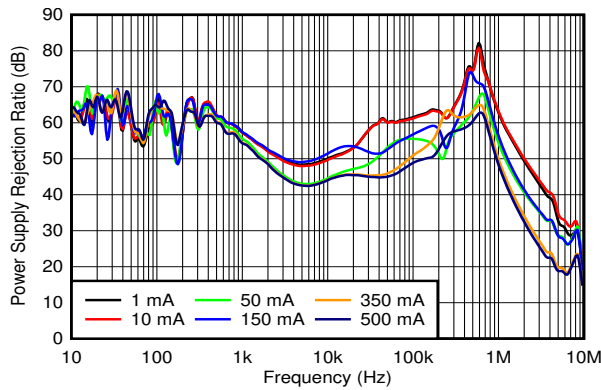
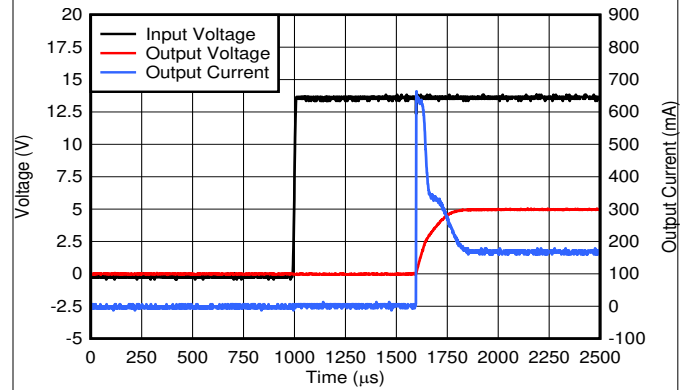

Figure 8-8. Power-Supply Ripple Rejection vs Frequency and I_{OUT} (New Chip)



$$V_{IN} = V_{OUT} + 1V, V_{OUT} = 90\% \times V_{OUT(NOM)}$$

Figure 8-9. Start-Up Plot Inrush Current (New Chip)

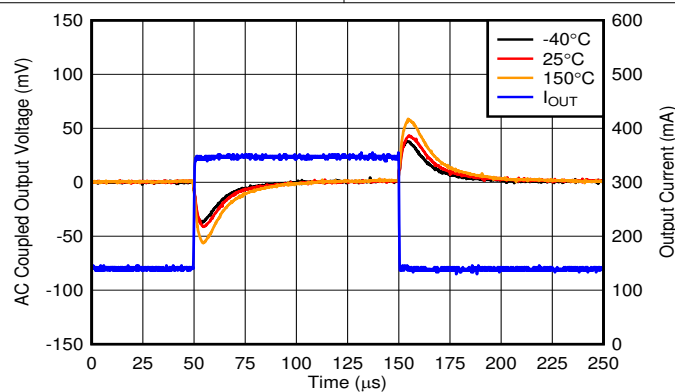

Figure 8-10. Transient Response (New Chip)

8.3 Power Supply Recommendations

This device is designed for operation from a 4V to 40V input voltage supply. Make sure this input supply is well regulated. Do not place the input supply more than a few inches from the TL720M05-Q1. If this location is unavoidable, add a 22 μ F electrolytic capacitor and a ceramic bypass capacitor at the input.

8.4 Layout

8.4.1 Layout Guidelines

For best overall performance, place all circuit components on the same side of the circuit board. Place these components as near as practical to the respective LDO pin connections. Place ground return connections to the input and output capacitor, and to the LDO ground pin as close as possible to each other. Use wide, component-side, copper surface for these connections. Using vias and long traces to the input and output capacitors is strongly discouraged and negatively affects system performance. Place a ground reference plane embedded in the PCB or located on the bottom side of the PCB opposite the components. This reference plane provides output voltage accuracy and shields noise. This plane also behaves similar to a thermal plane to spread (or sink) heat from the LDO device when connected to the thermal pad. In most applications, this ground plane is necessary to meet thermal requirements.

8.4.2 Layout Examples

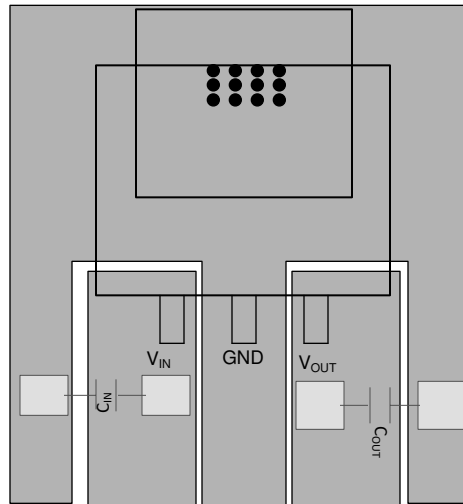

● Denotes a via

Figure 8-11. Layout Example Diagram for KVV, KTT Packages

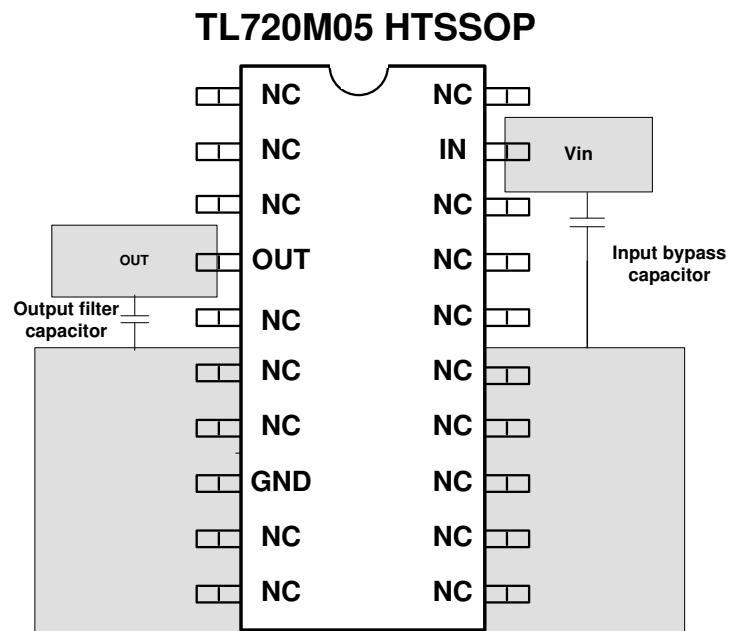

Figure 8-12. Layout Example Diagram for PWP Package (Legacy Chip)

9 Device and Documentation Support

9.1 Device Support

9.1.1 Evaluation Module

An evaluation module (EVM) is available to assist in the initial circuit performance evaluation using the TLV709. Request the [MLTLDO2EVM evaluation module](#) (and related [user's guide](#)) at the TI website through the product folders.

9.1.2 Device Nomenclature

Table 9-1. Device Nomenclature

PRODUCT ⁽¹⁾	V _{OUT}
TL720M05Q xxxRQ1	xxx is the package designation (for example, KVVU = TO-252; KTT = DDPAK/TO-263; PWP = HTSSOP). Q indicates that this device is a grade-1 device in accordance with the AEC-Q100 standard. Q1 indicates that this device is an automotive grade (AEC-Q100) device.

(1) For the most current package and ordering information see the Package Option Addendum at the end of this document, or visit the device product folder on [www.ti.com](#).

9.1.3 Development Support

For the PSpice model, see the [TPS7B88-Q1 \(5-V Output\) PSpice Transient Model](#).

9.2 Documentation Support

9.2.1 Related Documentation

For related documentation, see the following:

- Texas Instruments, [LDO Noise Demystified application note](#)
- Texas Instruments, [LDO PSRR Measurement Simplified application note](#)
- Texas Instruments, [MLTLDO2EVM-037 EVM user guide](#)

9.3 Receiving Notification of Documentation Updates

To receive notification of documentation updates, navigate to the device product folder on [ti.com](#). Click on *Notifications* to register and receive a weekly digest of any product information that has changed. For change details, review the revision history included in any revised document.

9.4 Support Resources

[TI E2E™ support forums](#) are an engineer's go-to source for fast, verified answers and design help — straight from the experts. Search existing answers or ask your own question to get the quick design help you need.

Linked content is provided "AS IS" by the respective contributors. They do not constitute TI specifications and do not necessarily reflect TI's views; see TI's [Terms of Use](#).

9.5 Trademarks

TI E2E™ is a trademark of Texas Instruments.
All trademarks are the property of their respective owners.

9.6 Electrostatic Discharge Caution



This integrated circuit can be damaged by ESD. Texas Instruments recommends that all integrated circuits be handled with appropriate precautions. Failure to observe proper handling and installation procedures can cause damage.

ESD damage can range from subtle performance degradation to complete device failure. Precision integrated circuits may be more susceptible to damage because very small parametric changes could cause the device not to meet its published specifications.

9.7 Glossary

[TI Glossary](#) This glossary lists and explains terms, acronyms, and definitions.

10 Revision History

NOTE: Page numbers for previous revisions may differ from page numbers in the current version.

Changes from Revision H (November 2014) to Revision I (May 2024)	Page
• Updated the numbering format for tables, figures, and cross-references throughout the document.....	1
• Changed entire document to align with current family format.....	1
• Added M3 devices to document.....	1
• Changed <i>package size</i> values in <i>Package Information</i> table.....	1

Changes from Revision G (June 2013) to Revision H (July 2015)	Page
• Added <i>ESD Ratings</i> table, <i>Feature Description</i> section, <i>Device Functional Modes, Application and Implementation</i> section, <i>Power Supply Recommendations</i> section, <i>Layout</i> section, <i>Device and Documentation Support</i> section, and <i>Mechanical, Packaging, and Orderable Information</i> section	1

11 Mechanical, Packaging, and Orderable Information

The following pages include mechanical, packaging, and orderable information. This information is the most current data available for the designated devices. This data is subject to change without notice and revision of this document. For browser-based versions of this data sheet, refer to the left-hand navigation.

PACKAGING INFORMATION

Orderable Device	Status (1)	Package Type	Package Drawing	Pins	Package Qty	Eco Plan (2)	Lead finish/ Ball material (6)	MSL Peak Temp (3)	Op Temp (°C)	Device Marking (4/5)	Samples
TL720M05GQKVURQ1	ACTIVE	TO-252	KVU	3	2500	RoHS & Green	SN	Level-3-260C-168 HR	-40 to 125	720M05Q	Samples
TL720M05GQKVURQ1M3	ACTIVE	TO-252	KVU	3	2500	RoHS & Green	SN	Level-3-260C-168 HR	-40 to 125	720M05Q	Samples
TL720M05QKTTRQ1	ACTIVE	DDPAK/ TO-263	KTT	3	500	RoHS & Green	SN	Level-3-245C-168 HR	-40 to 125	T720M05Q	Samples
TL720M05QKVURQ1	ACTIVE	TO-252	KVU	3	2500	RoHS & Green	SN	Level-3-260C-168 HR	-40 to 125	720M05Q	Samples
TL720M05QKVURQ1M3	ACTIVE	TO-252	KVU	3	2500	RoHS & Green	SN	Level-3-260C-168 HR	-40 to 125	720M05Q	Samples
TL720M05QPWPRQ1	ACTIVE	HTSSOP	PWP	20	2000	RoHS & Green	NIPDAU	Level-3-260C-168 HR	-40 to 125	720M05Q	Samples

(1) The marketing status values are defined as follows:

ACTIVE: Product device recommended for new designs.

LIFEBUY: TI has announced that the device will be discontinued, and a lifetime-buy period is in effect.

NRND: Not recommended for new designs. Device is in production to support existing customers, but TI does not recommend using this part in a new design.

PREVIEW: Device has been announced but is not in production. Samples may or may not be available.

OBsolete: TI has discontinued the production of the device.

(2) **RoHS:** TI defines "RoHS" to mean semiconductor products that are compliant with the current EU RoHS requirements for all 10 RoHS substances, including the requirement that RoHS substance do not exceed 0.1% by weight in homogeneous materials. Where designed to be soldered at high temperatures, "RoHS" products are suitable for use in specified lead-free processes. TI may reference these types of products as "Pb-Free".

RoHS Exempt: TI defines "RoHS Exempt" to mean products that contain lead but are compliant with EU RoHS pursuant to a specific EU RoHS exemption.

Green: TI defines "Green" to mean the content of Chlorine (Cl) and Bromine (Br) based flame retardants meet JS709B low halogen requirements of <=1000ppm threshold. Antimony trioxide based flame retardants must also meet the <=1000ppm threshold requirement.

(3) MSL, Peak Temp. - The Moisture Sensitivity Level rating according to the JEDEC industry standard classifications, and peak solder temperature.

(4) There may be additional marking, which relates to the logo, the lot trace code information, or the environmental category on the device.

(5) Multiple Device Markings will be inside parentheses. Only one Device Marking contained in parentheses and separated by a "~" will appear on a device. If a line is indented then it is a continuation of the previous line and the two combined represent the entire Device Marking for that device.

(6) Lead finish/Ball material - Orderable Devices may have multiple material finish options. Finish options are separated by a vertical ruled line. Lead finish/Ball material values may wrap to two lines if the finish value exceeds the maximum column width.

Important Information and Disclaimer: The information provided on this page represents TI's knowledge and belief as of the date that it is provided. TI bases its knowledge and belief on information provided by third parties, and makes no representation or warranty as to the accuracy of such information. Efforts are underway to better integrate information from third parties. TI has taken and continues to take reasonable steps to provide representative and accurate information but may not have conducted destructive testing or chemical analysis on incoming materials and chemicals. TI and TI suppliers consider certain information to be proprietary, and thus CAS numbers and other limited information may not be available for release.

In no event shall TI's liability arising out of such information exceed the total purchase price of the TI part(s) at issue in this document sold by TI to Customer on an annual basis.

TAPE AND REEL INFORMATION

QUADRANT ASSIGNMENTS FOR PIN 1 ORIENTATION IN TAPE

*All dimensions are nominal

Device	Package Type	Package Drawing	Pins	SPQ	Reel Diameter (mm)	Reel Width W1 (mm)	A0 (mm)	B0 (mm)	K0 (mm)	P1 (mm)	W (mm)	Pin1 Quadrant
TL720M05GQKVURQ1	TO-252	KVU	3	2500	330.0	16.4	6.9	10.5	2.7	8.0	16.0	Q2
TL720M05GQKVURQ1M3	TO-252	KVU	3	2500	330.0	16.4	6.9	10.5	2.7	8.0	16.0	Q2
TL720M05QKVURQ1	TO-252	KVU	3	2500	330.0	16.4	6.9	10.5	2.7	8.0	16.0	Q2
TL720M05QKVURQ1M3	TO-252	KVU	3	2500	330.0	16.4	6.9	10.5	2.7	8.0	16.0	Q2
TL720M05QPWPRQ1	HTSSOP	PWP	20	2000	330.0	16.4	6.95	7.1	1.6	8.0	16.0	Q1

TAPE AND REEL BOX DIMENSIONS

*All dimensions are nominal

Device	Package Type	Package Drawing	Pins	SPQ	Length (mm)	Width (mm)	Height (mm)
TL720M05GQKVURQ1	TO-252	KVU	3	2500	340.0	340.0	38.0
TL720M05GQKVURQ1M3	TO-252	KVU	3	2500	340.0	340.0	38.0
TL720M05QKVURQ1	TO-252	KVU	3	2500	340.0	340.0	38.0
TL720M05QKVURQ1M3	TO-252	KVU	3	2500	340.0	340.0	38.0
TL720M05QPWPRQ1	HTSSOP	PWP	20	2000	350.0	350.0	43.0

KTT (R-PSFM-G3)

PLASTIC FLANGE-MOUNT PACKAGE

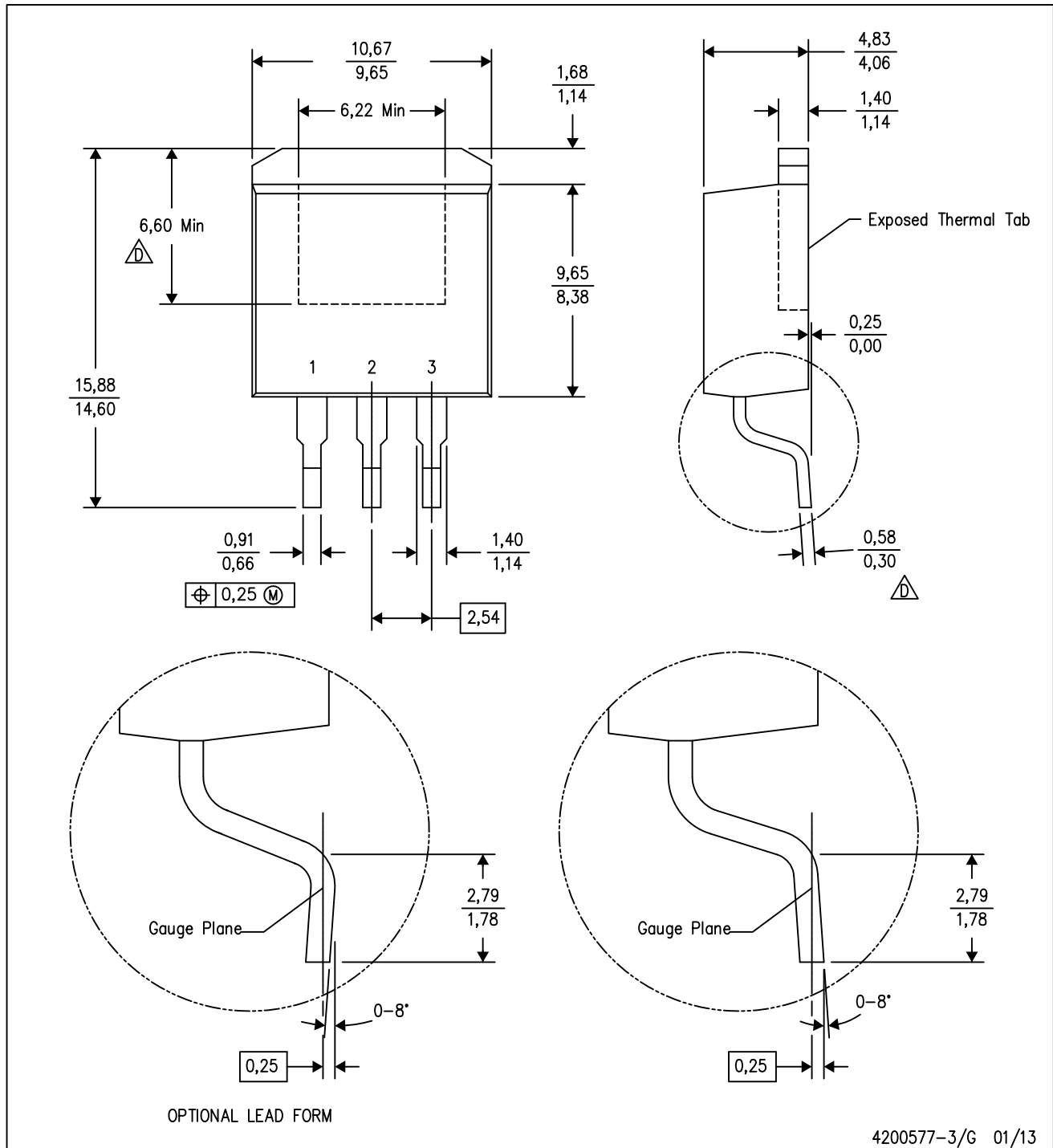

4200577-3/G 01/13

- NOTES:
- A. All linear dimensions are in millimeters.
 - B. This drawing is subject to change without notice.
 - C. Body dimensions do not include mold flash or protrusion. Mold flash or protrusion not to exceed 0.005 (0,13) per side.
- Falls within JEDEC TO-263 variation AA, except minimum lead thickness and minimum exposed pad length.

KTT (R-PSFM-G3)

PLASTIC FLANGE-MOUNT PACKAGE

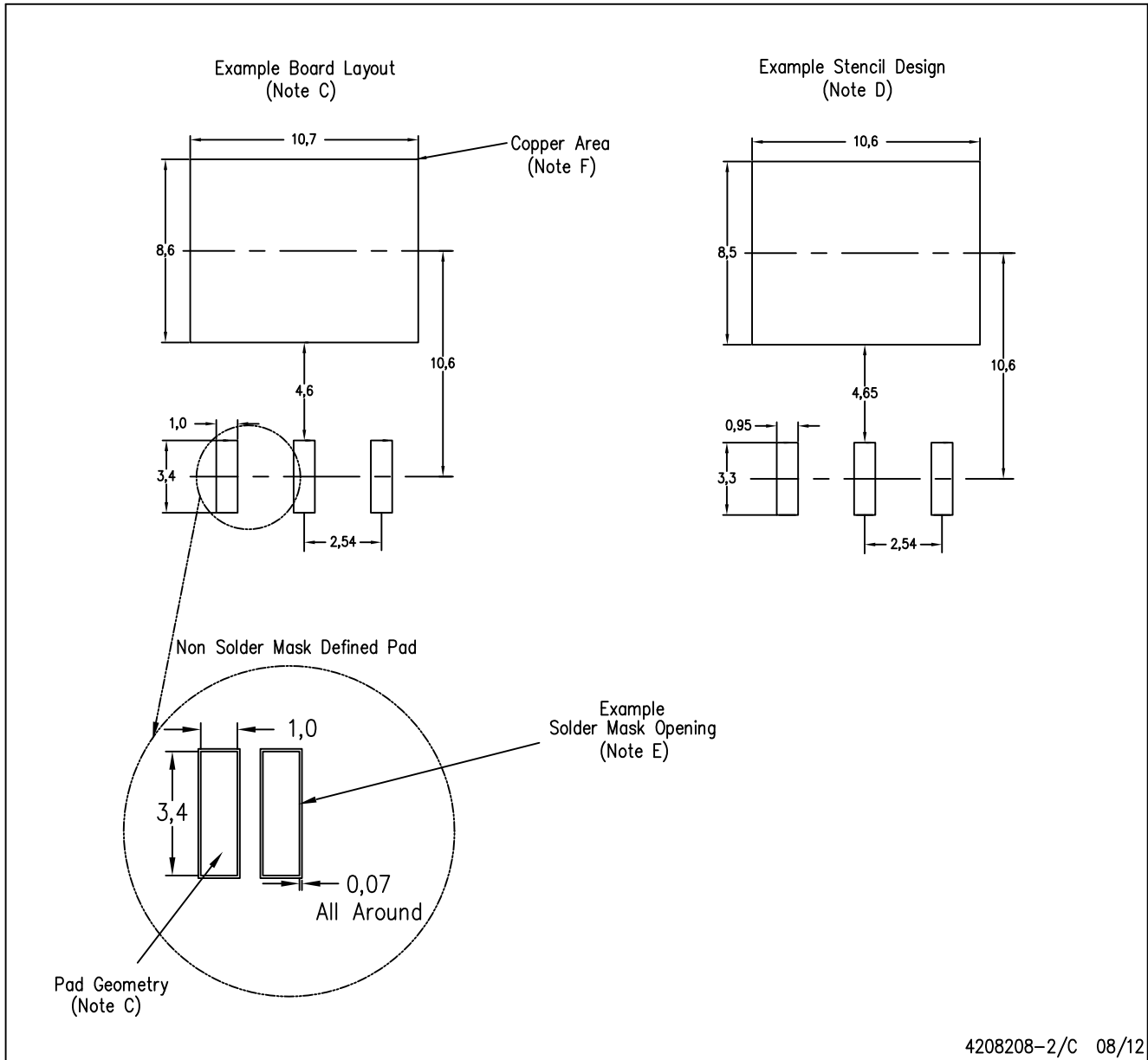

- NOTES:
- All linear dimensions are in millimeters.
 - This drawing is subject to change without notice.
 - Publication IPC-SM-782 is recommended for alternate designs.
 - Laser cutting apertures with trapezoidal walls and also rounding corners will offer better paste release. Customers should contact their board assembly site for stencil design recommendations. Refer to IPC-7525.
 - Customers should contact their board fabrication site for solder mask tolerances between and around signal pads.
 - This package is designed to be soldered to a thermal pad on the board. Refer to the Product Datasheet for specific thermal information, via requirements, and recommended thermal pad size. For thermal pad sizes larger than shown a solder mask defined pad is recommended in order to maintain the solderable pad geometry while increasing copper area.

GENERIC PACKAGE VIEW

PWP 20

HTSSOP - 1.2 mm max height

6.5 x 4.4, 0.65 mm pitch

SMALL OUTLINE PACKAGE

This image is a representation of the package family, actual package may vary.
Refer to the product data sheet for package details.

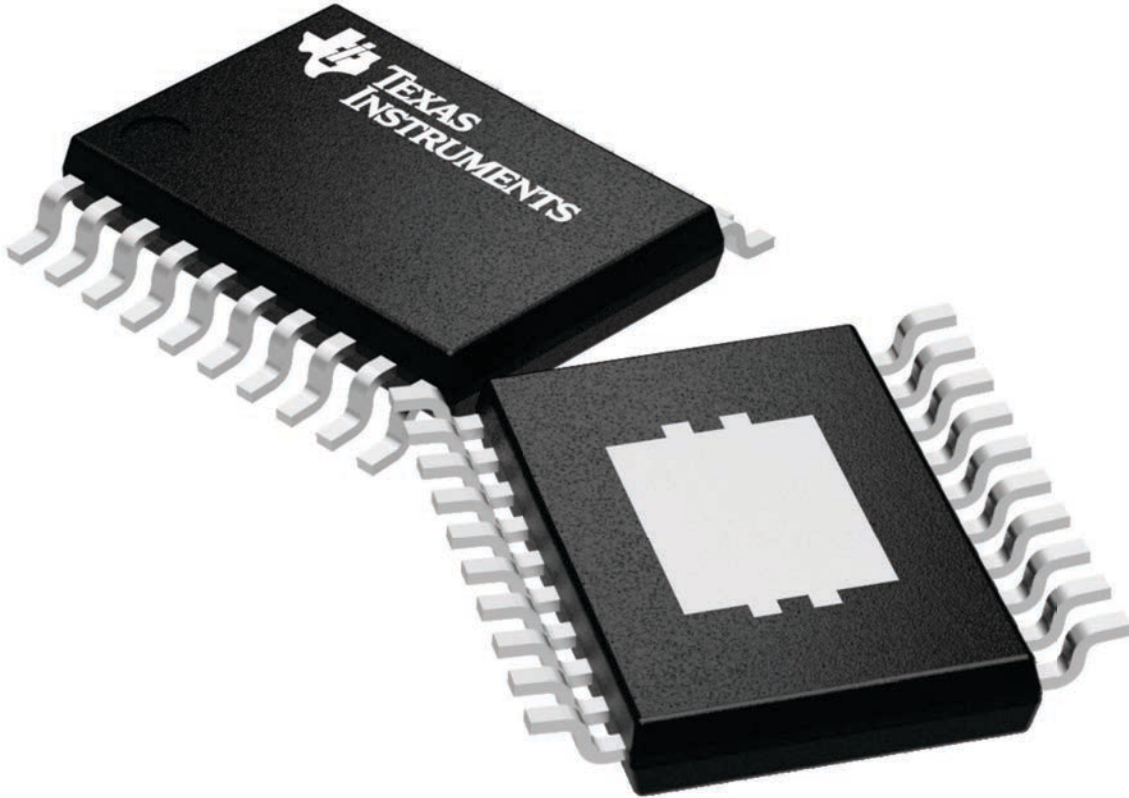

4224669/A

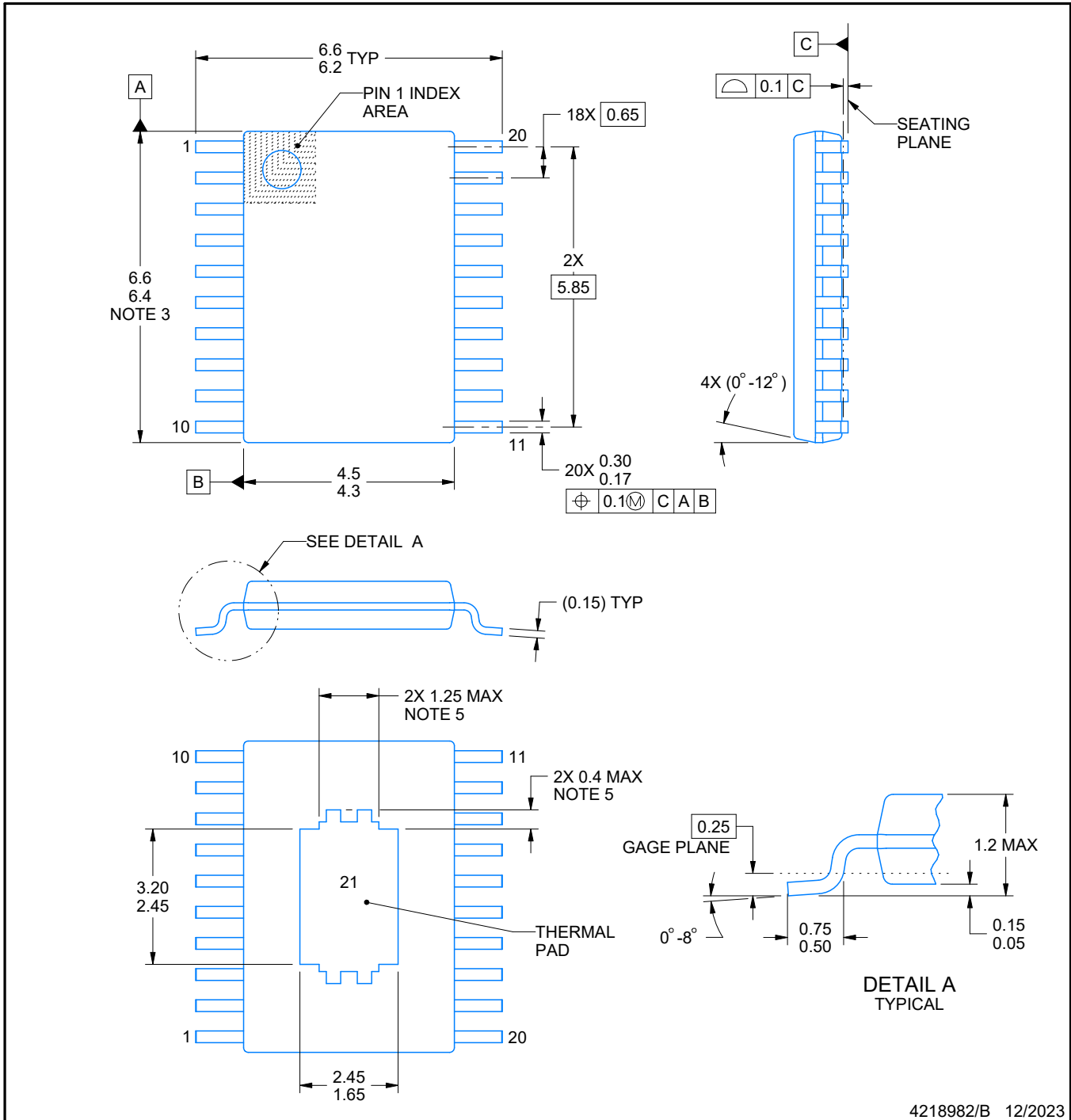
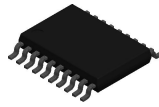

4218982/B 12/2023

PowerPAD is a trademark of Texas Instruments.

NOTES:

1. All linear dimensions are in millimeters. Any dimensions in parenthesis are for reference only. Dimensioning and tolerancing per ASME Y14.5M.
2. This drawing is subject to change without notice.
3. This dimension does not include mold flash, protrusions, or gate burrs. Mold flash, protrusions, or gate burrs shall not exceed 0.15 mm per side.
4. Reference JEDEC registration MO-153.
5. Features may differ or may not be present.

EXAMPLE BOARD LAYOUT

PWP0020N

PowerPAD™ TSSOP - 1.2 mm max height

SMALL OUTLINE PACKAGE

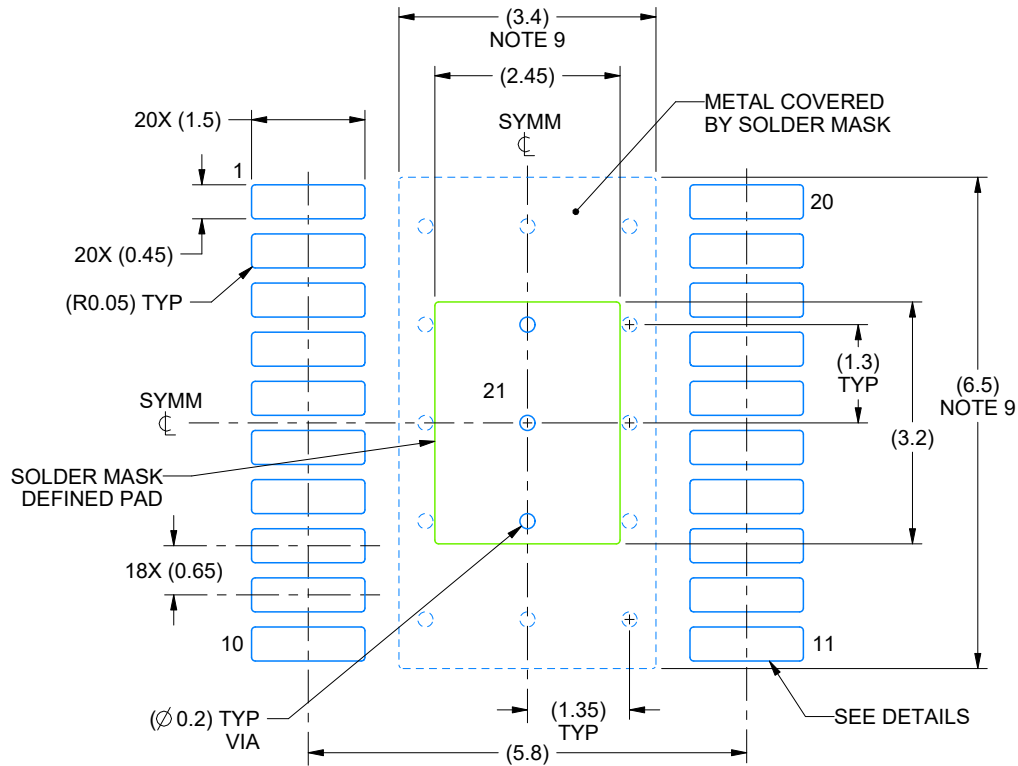

LAND PATTERN EXAMPLE
EXPOSED METAL SHOWN
SCALE: 10X

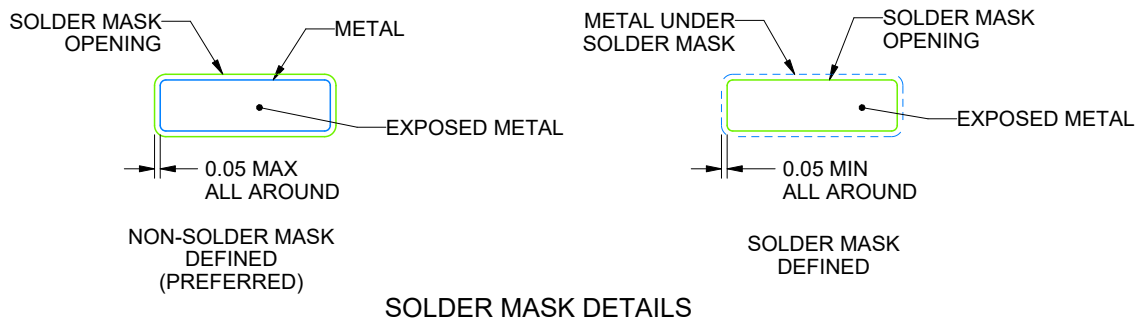

SOLDER MASK DETAILS

4218982/B 12/2023

NOTES: (continued)

6. Publication IPC-7351 may have alternate designs.
7. Solder mask tolerances between and around signal pads can vary based on board fabrication site.
8. This package is designed to be soldered to a thermal pad on the board. For more information, see Texas Instruments literature numbers SLMA002 (www.ti.com/lit/slma002) and SLMA004 (www.ti.com/lit/slma004).
9. Size of metal pad may vary due to creepage requirement.
10. Vias are optional depending on application, refer to device data sheet. It is recommended that vias under paste be filled, plugged or tented.

EXAMPLE STENCIL DESIGN

PWP0020N

PowerPAD™ TSSOP - 1.2 mm max height

SMALL OUTLINE PACKAGE

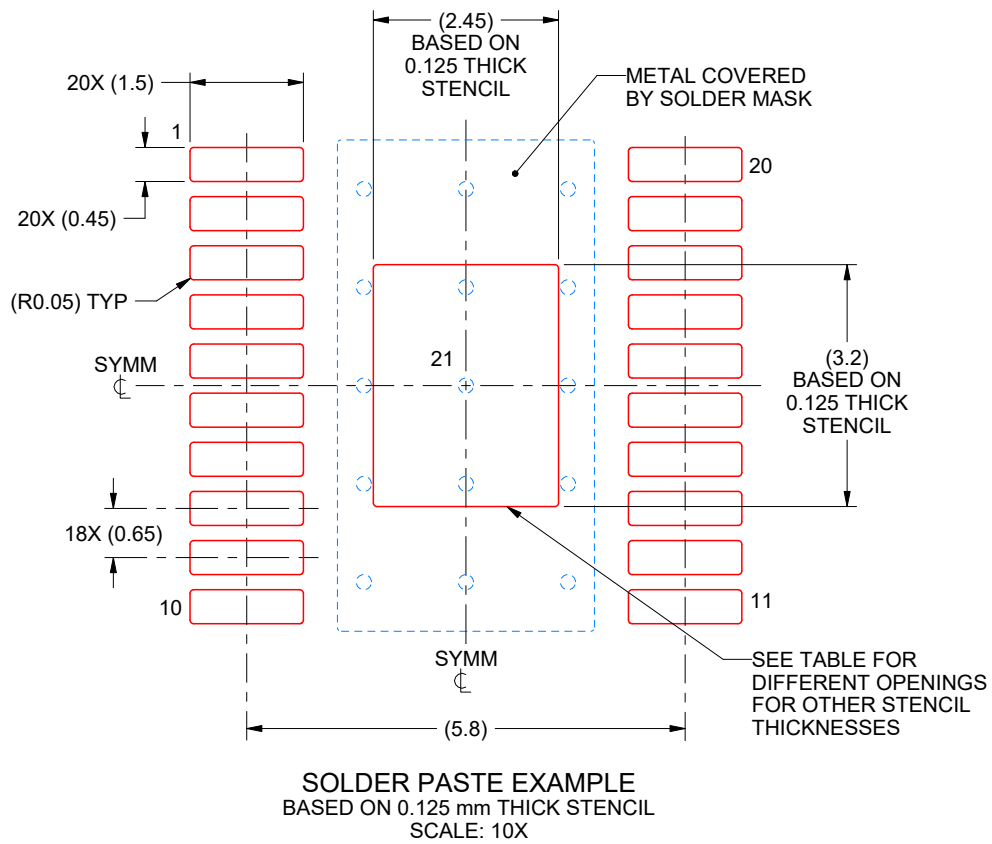

STENCIL THICKNESS	SOLDER STENCIL OPENING
0.1	2.74 X 3.58
0.125	2.5 X 3.2 (SHOWN)
0.15	2.24 X 2.92
0.175	2.07 X 2.70

4218982/B 12/2023

NOTES: (continued)

11. Laser cutting apertures with trapezoidal walls and rounded corners may offer better paste release. IPC-7525 may have alternate design recommendations.
12. Board assembly site may have different recommendations for stencil design.

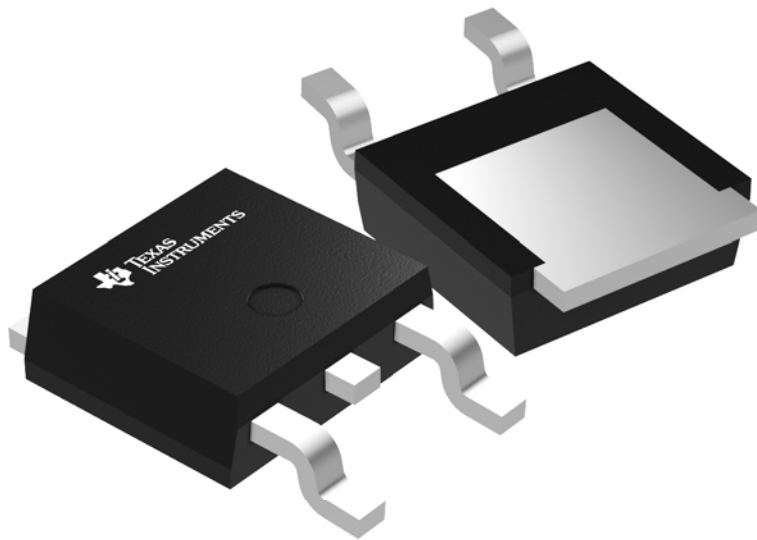

Images above are just a representation of the package family, actual package may vary.
Refer to the product data sheet for package details.

EXAMPLE BOARD LAYOUT

KVU0003A

TO-252 - 2.52 mm max height

TO-252

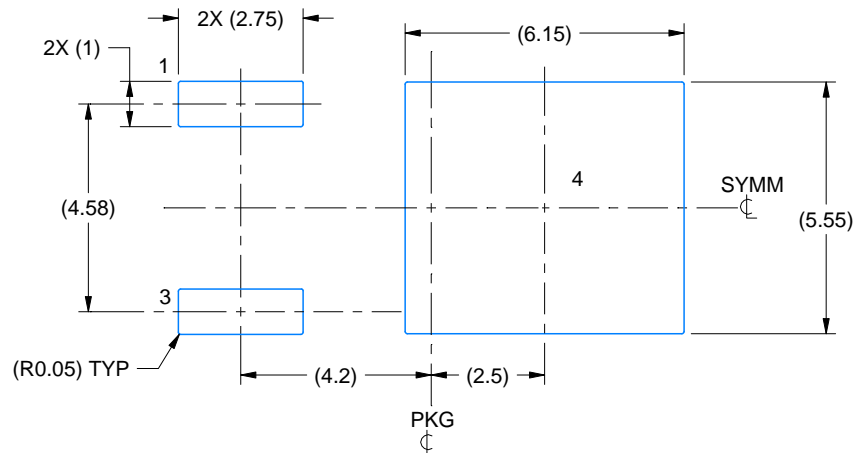

LAND PATTERN EXAMPLE
EXPOSED METAL SHOWN
SCALE:6X

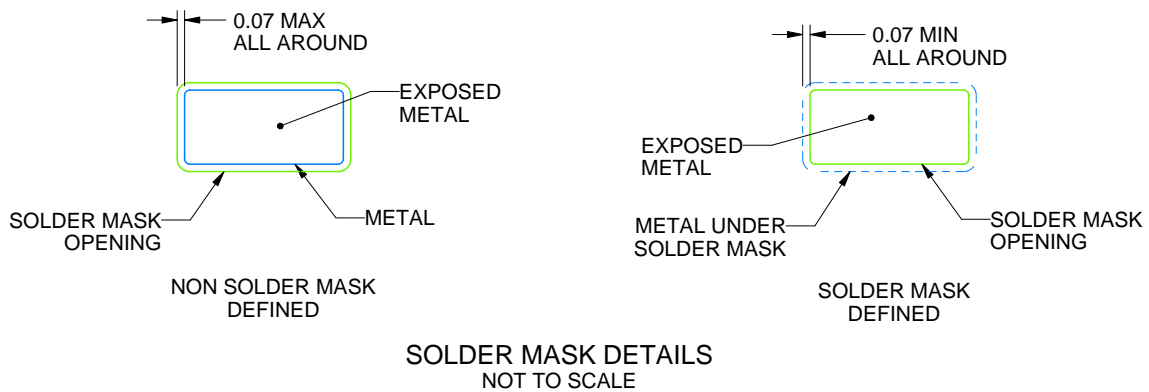

SOLDER MASK DETAILS
NOT TO SCALE

4218915/A 02/2017

NOTES: (continued)

5. This package is designed to be soldered to a thermal pad on the board. For more information, see Texas Instruments literature numbers SLMA002(www.ti.com/lit/slm002) and SLMA004 (www.ti.com/lit/slma004).
6. Vias are optional depending on application, refer to device data sheet. It is recommended that vias under paste be filled, plugged or tented.

EXAMPLE STENCIL DESIGN

KVU0003A

TO-252 - 2.52 mm max height

TO-252

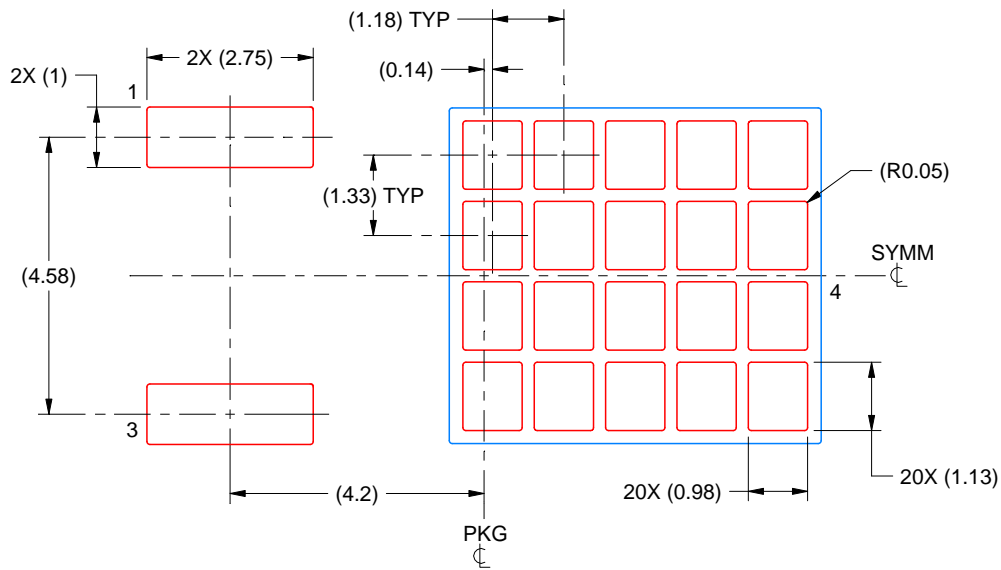

SOLDER PASTE EXAMPLE
BASED ON 0.125 mm THICK STENCIL

EXPOSED PAD
65% PRINTED SOLDER COVERAGE BY AREA
SCALE:8X

4218915/A 02/2017

NOTES: (continued)

7. Laser cutting apertures with trapezoidal walls and rounded corners may offer better paste release. IPC-7525 may have alternate design recommendations.
8. Board assembly site may have different recommendations for stencil design.

IMPORTANT NOTICE AND DISCLAIMER

TI PROVIDES TECHNICAL AND RELIABILITY DATA (INCLUDING DATA SHEETS), DESIGN RESOURCES (INCLUDING REFERENCE DESIGNS), APPLICATION OR OTHER DESIGN ADVICE, WEB TOOLS, SAFETY INFORMATION, AND OTHER RESOURCES "AS IS" AND WITH ALL FAULTS, AND DISCLAIMS ALL WARRANTIES, EXPRESS AND IMPLIED, INCLUDING WITHOUT LIMITATION ANY IMPLIED WARRANTIES OF MERCHANTABILITY, FITNESS FOR A PARTICULAR PURPOSE OR NON-INFRINGEMENT OF THIRD PARTY INTELLECTUAL PROPERTY RIGHTS.

These resources are intended for skilled developers designing with TI products. You are solely responsible for (1) selecting the appropriate TI products for your application, (2) designing, validating and testing your application, and (3) ensuring your application meets applicable standards, and any other safety, security, regulatory or other requirements.

These resources are subject to change without notice. TI grants you permission to use these resources only for development of an application that uses the TI products described in the resource. Other reproduction and display of these resources is prohibited. No license is granted to any other TI intellectual property right or to any third party intellectual property right. TI disclaims responsibility for, and you will fully indemnify TI and its representatives against, any claims, damages, costs, losses, and liabilities arising out of your use of these resources.

TI's products are provided subject to [TI's Terms of Sale](#) or other applicable terms available either on [ti.com](https://www.ti.com) or provided in conjunction with such TI products. TI's provision of these resources does not expand or otherwise alter TI's applicable warranties or warranty disclaimers for TI products.

TI objects to and rejects any additional or different terms you may have proposed.

Mailing Address: Texas Instruments, Post Office Box 655303, Dallas, Texas 75265

Copyright © 2025, Texas Instruments Incorporated