

TMUX1072 2-Channel 2:1 Analog Multiplexer with Overvoltage Detection and Protection

1 Features

- Supply range 2.3 V to 5.5 V
- Powered off protection: I/O pins Hi-Z when $V_{CC} = 0$ V
- 6-V Overvoltage and overtemperature detection with fault indicator pin
- 18-V Overvoltage protection (OVP) on common pins
- Support signals beyond V_{CC} up to 5.5 V
- Low R_{ON} of 6 Ω
- BW of 1.2 GHz typical
- C_{ON} of 4.5 pF typical
- Low power disable mode
- 1.8-V Compatible logic inputs
- ESD protection exceeds JESD22
 - 2000-V Human body model (HBM)
- Small 2.00 mm x 1.70 mm QFN package available

2 Applications

- [Data acquisition \(DAQ\)](#)
- Field instrumentation
- [Video surveillance](#)
- [HVAC systems](#)
- [Rear camera](#)

3 Description

The TMUX1072 is a high-speed, 2-channel, 2:1, analog switch with integrated overvoltage detection and powered off protection. The device is bidirectional and can be used as a 2:1 or 1:2 switch while supporting signals beyond V_{CC} up to 5.5 V.

The protection on the I/O pins of the TMUX1072 tolerates a maximum of 18 V with automatic shutoff circuitry to prevent damage to system components behind the switch. This protection is used for power sequencing. Some boards in the system may be powered up before others are ready to receive signals. The device detects overvoltage and overtemperature events, and provides an open drain output signal through the \overline{FLT} pin.

Device Information⁽¹⁾

PART NUMBER	PACKAGE	BODY SIZE (NOM)
TMUX1072	UQFN (12)	2.00 mm x 1.70 mm
	VSSOP (10)	3.00 mm x 5.00 mm

(1) For all available packages, see the orderable addendum at the end of the data sheet.

Simplified Schematic

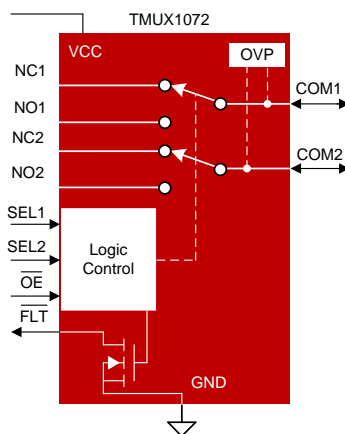

Table of Contents

1 Features	1	8.3 Feature Description	15
2 Applications	1	8.4 Device Functional Modes	16
3 Description	1	9 Application and Implementation	17
4 Revision History	2	9.1 Application Information	17
5 Pin Configuration and Functions	3	9.2 Typical Application	17
6 Specifications	4	10 Power Supply Recommendations	18
6.1 Absolute Maximum Ratings	4	11 Layout	18
6.2 ESD Ratings	4	11.1 Layout Guidelines	18
6.3 Recommended Operating Conditions	4	11.2 Layout Example	19
6.4 Thermal Information	5	12 Device and Documentation Support	20
6.5 Electrical Characteristics	5	12.1 Documentation Support	20
6.6 Dynamic Characteristics	8	12.2 Receiving Notification of Documentation Updates	20
6.7 Timing Requirements	8	12.3 Community Resources	20
6.8 Typical Characteristics	9	12.4 Trademarks	20
7 Parameter Measurement Information	10	12.5 Electrostatic Discharge Caution	20
8 Detailed Description	14	12.6 Glossary	20
8.1 Overview	14	13 Mechanical, Packaging, and Orderable Information	20
8.2 Functional Block Diagram	14		

4 Revision History

NOTE: Page numbers for previous revisions may differ from page numbers in the current version.

Changes from Revision B (June 2019) to Revision C	Page
• Added Typical Characteristics curves for AC parameters	9
• Added the <i>Application Curves</i> section	18

Changes from Revision A (August 2018) to Revision B	Page
• Changed <i>Feature</i> From: 0-V to 18-V Overvoltage Protection (OVP) on Common Pins To: 0-V to 6-V Overvoltage protection (OVP) on common pins	1

Changes from Original (April 2018) to Revision A	Page
• Changed the device status From: <i>Advanced Information</i> To <i>Production</i> data	1

5 Pin Configuration and Functions

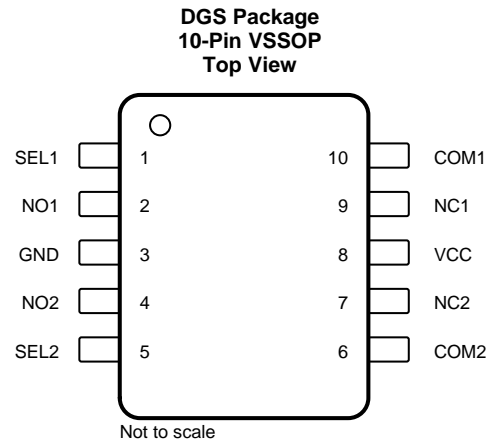
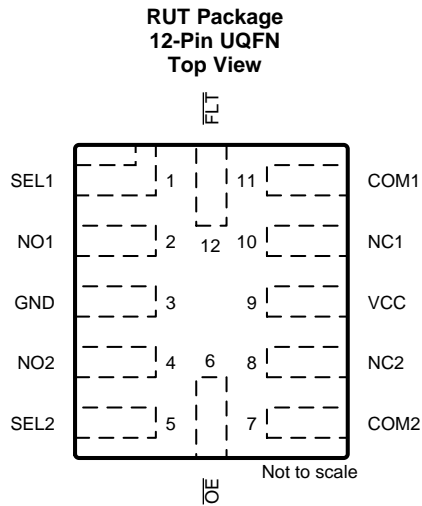

Pin Functions

NAME	PIN		I/O	DESCRIPTION
	RUT	DGS		
SEL1	1	1	I	Switch select 1
NO1	2	2	I/O	Signal path NO1
GND	3	3	GND	Ground
NO2	4	4	I/O	Signal path NO2
SEL2	5	5	I	Switch select 2
$\overline{\text{OE}}$	6	-	I	Output enable (Active low)
COM2	7	6	I/O	Common signal path 2
NC2	8	7	I/O	Signal path NC2
VCC	9	8	PWR	Supply Voltage
NC1	10	9	I/O	Signal path NC1
COM1	11	10	I/O	Common signal path 1
$\overline{\text{FLT}}$	12	-	O	Fault indicator output pin (Active low) - open drain. If feature is unused, pin may be left floating or connected to ground

6 Specifications

6.1 Absolute Maximum Ratings

 over operating free-air temperature range (unless otherwise noted)^{(1) (2)}

		MIN	MAX	UNIT
V _{CC}	Supply voltage ⁽³⁾	-0.5	6	V
V _{I/O}	Input/Output DC voltage (COM1, COM2) ⁽³⁾	-0.5	20	V
	Input/Output DC voltage (NC1, NO1, NC2, NO2) ⁽³⁾	-0.5	6	V
V _I	Digital input voltage (SEL1, SEL2, \overline{OE})	-0.5	6	V
V _O	Digital output voltage (\overline{FLT})	-0.5	6	V
I _K	Input-output port diode current (COM1, COM2, NC1, NO1, NC2, NO2)	V _{IN} < 0	-50	mA
I _{IK}	Digital logic input clamp current (SEL1, SEL2, \overline{OE}) ⁽³⁾	V _I < 0	-50	mA
I _{CC}	Continuous current through VCC		100	mA
I _{GND}	Continuous current through GND	-100		mA
T _{stg}	Storage temperature	-65	150	°C
T _J	Operating Junction Temperature	-65	150	°C

- (1) Stresses beyond those listed under *Absolute Maximum Ratings* may cause permanent damage to the device. These are stress ratings only, which do not imply functional operation of the device at these or any other conditions beyond those indicated under *Recommended Operating Conditions*. Exposure to absolute-maximum-rated conditions for extended periods may affect device reliability.
- (2) The algebraic convention, whereby the most negative value is a minimum and the most positive value is a maximum.
- (3) All voltages are with respect to ground, unless otherwise specified.

6.2 ESD Ratings

		VALUE	UNIT
V _(ESD)	Electrostatic discharge	Human body model (HBM), per ANSI/ESDA/JEDEC JS-001 ⁽¹⁾	±2000
		Charged-device model (CDM), per JEDEC specification JESD22-C101 ⁽²⁾	±1000

- (1) JEDEC document JEP155 states that 500-V HBM allows safe manufacturing with a standard ESD control process.
- (2) JEDEC document JEP157 states that 250-V CDM allows safe manufacturing with a standard ESD control process.

6.3 Recommended Operating Conditions

		MIN	MAX	UNIT
V _{CC}	Supply voltage	2.3	5.5	V
V _{I/O}	Analog input/output	COM1, COM2	0	18
V _{I/O}		(NC1, NO1, NC2, NO2)	0	5.5
I _{I/O}		COM1, COM2	-50	50
I _{I/O}		(NC1, NO1, NC2, NO2)	-50	50
V _I	Digital input voltage	SEL1, SEL2, \overline{OE}	0	5.5
V _O	Digital output voltage	\overline{FLT}	0	5.5
I _{I/O}	Analog input/output port continuous current	(COM1, COM2, NC1, NO1, NC2, NO2)	-50	50
I _{OL}	Digital output current		3	mA
T _A	Operating free-air temperature	-40	125	°C
T _J	Junction temperature	-40	125	°C

6.4 Thermal Information

THERMAL METRIC ⁽¹⁾		TMUX1072		UNIT
		RUT (UQFN)	DGS (VSSOP)	
		12 PINS	10 PINS	
$R_{\theta JA}$	Junction-to-ambient thermal resistance	127	175	°C/W
$R_{\theta JC(top)}$	Junction-to-case (top) thermal resistance	55.5	61.2	°C/W
$R_{\theta JB}$	Junction-to-board thermal resistance	67.7	96.9	°C/W
ψ_{JT}	Junction-to-top characterization parameter	1.6	8.2	°C/W
ψ_{JB}	Junction-to-board characterization parameter	67.3	95.1	°C/W

(1) For more information about traditional and new thermal metrics, see the [Semiconductor and IC Package Thermal Metrics](#) application report.

6.5 Electrical Characteristics

$T_A = -40^\circ\text{C}$ to $+125^\circ\text{C}$, $V_{CC} = 2.3\text{ V}$ to 5.5 V , $GND = 0\text{V}$, Typical values are at $V_{CC} = 3.3\text{ V}$, $T_A = 25^\circ\text{C}$, (unless otherwise noted)

PARAMETER		TEST CONDITIONS	MIN	TYP	MAX	UNIT
SUPPLY						
V_{CC}	Power supply voltage		2.3		5.5	V
I_{CC}	Active supply current	$\overline{OE} = 0\text{ V}$ SEL1, SEL2 = 0 V, 1.8 V or V_{CC} $0\text{ V} < V_{IO} < 3.6\text{ V}$		75	110	μA
	Supply current during OVP condition	$\overline{OE} = 0\text{ V}$ SEL1, SEL2 = 0 V, 1.8 V or V_{CC} $V_{IO} > V_{POS_THLD}$		65	98	μA
$I_{CC_PD}^{(1)}$	Standby powered down supply current	$\overline{OE} = 1.8\text{ V}$ or V_{CC} SEL1 = 0 V, 1.8 V, or V_{CC} SEL2 = 0 V, 1.8 V, or V_{CC}		3	10	μA
UVLO	Under Voltage Lock Out	$V_{CC} = \text{rising and falling}$	1.65			V
DC Characteristics						
R_{ON}	ON-state resistance	$V_{IO} = 0\text{ V}$ to V_{CC} $I_{SINK} = 8\text{ mA}$ Refer to ON-State Resistance Figure		6	18	Ω
ΔR_{ON}	ON-state resistance match between channels	$V_{IO} = 0\text{ V}$ to V_{CC} $I_{SINK} = 8\text{ mA}$ Refer to ON-State Resistance Figure		0.07	0.5	Ω
$R_{ON (FLAT)}$	ON-state resistance flatness	$V_{IO} = 0\text{ V}$ to V_{CC} $I_{SINK} = 8\text{ mA}$ Refer to ON-State Resistance Figure		2.5	7	Ω

(1) Not tested for DGS package due to absence of FLT and OE pin.

Electrical Characteristics (continued)

$T_A = -40^{\circ}\text{C}$ to $+125^{\circ}\text{C}$, $V_{CC} = 2.3\text{ V}$ to 5.5 V , $\text{GND} = 0\text{V}$, Typical values are at $V_{CC} = 3.3\text{ V}$, $T_A = 25^{\circ}\text{C}$, (unless otherwise noted)

PARAMETER		TEST CONDITIONS	MIN	TYP	MAX	UNIT	
I_{OFF}	I/O pin OFF leakage current	$V_{\text{COM}1/2} = 0\text{ V}$ to 5.5 V ⁽²⁾ $V_{CC} = 2.3\text{ V}$ to 5.5 V $V_{\text{NC}1/2}$ or $V_{\text{NO}1/2} = 5.5\text{ V}$ or 0 V Refer to Off Leakage Figure		3.6	10	μA	
		$V_{\text{COM}1/2} = 5.5\text{ V}$ ⁽²⁾ $V_{CC} = 5.5\text{ V}$ $V_{\text{NC}1/2}$ or $V_{\text{NO}1/2} = 5.5\text{ V}$ Refer to Off Leakage Figure			3	μA	
		$V_{\text{COM}1/2} = 3.6\text{ V}$ ⁽²⁾ $V_{CC} = 3.3\text{ V}$ $V_{\text{NC}1/2}$ or $V_{\text{NO}1/2} = 3.6\text{ V}$ Refer to Off Leakage Figure				2	μA
		$V_{\text{COM}1/2} = 5.5\text{ V}$ $V_{CC} = 0\text{ V}$ $V_{\text{NC}1/2}$ or $V_{\text{NO}1/2} = 5.5\text{ V}$ Refer to Off Leakage Figure				15	μA
		$V_{\text{COM}1/2} = 3.6\text{ V}$ $V_{CC} = 0\text{ V}$ $V_{\text{NC}1/2}$ or $V_{\text{NO}1/2} = 3.6\text{ V}$ Refer to Off Leakage Figure				10	μA
		$V_{\text{COM}1/2} = 1\text{ V}$ $V_{CC} = 0\text{ V}$ $V_{\text{NC}1/2}$ or $V_{\text{NO}1/2} = 1\text{ V}$ Refer to Off Leakage Figure				2	μA
		$V_{\text{COM}1/2} = 18\text{ V}$ $V_{CC} = 0\text{ V}, 5.5\text{ V}$ $V_{\text{NC}1/2}$ or $V_{\text{NO}1/2} = 0\text{ V}$ Refer to Off Leakage Figure			165	185	μA
I_{ON}	ON leakage current	$V_{\text{COM}1/2} = 5.5\text{ V}$ $V_{CC} = 5.5\text{ V}$ $V_{\text{NC}1/2}$ and $V_{\text{NO}1/2} = \text{high-Z}$ Refer to On Leakage Figure		1.2	3.5	μA	
		$V_{\text{COM}1/2} = 0\text{ V}$ to 5.5 V $V_{CC} = 2.3\text{-}5.5\text{ V}$ $V_{\text{NC}1/2}$ and $V_{\text{NO}1/2} = \text{high-Z}$ Refer to On Leakage Figure			11.5	μA	
Digital Characteristics							
V_{IH}	Input logic high	SEL1, SEL2, $\overline{\text{OE}}$	1.45			V	
V_{IL}	Input logic low	SEL1, SEL2, $\overline{\text{OE}}$			0.5	V	
V_{OL}	Output logic low	$\overline{\text{FLT}}$ $I_{\text{OL}} = 3\text{ mA}$			0.3	V	
I_{IH}	Input high leakage current	SEL1, SEL2, $\overline{\text{OE}} = 1.8\text{ V}$, V_{CC}	-1	2	5	μA	
I_{IL}	Input low leakage current	SEL1, SEL2, $\overline{\text{OE}} = 0\text{ V}$	-1	± 0.2	1	μA	
R_{PD}	Internal pull-down resistor on digital input pins	SEL1, SEL2		6	12	$\text{M}\Omega$	
		$\overline{\text{OE}}$		3	6	$\text{M}\Omega$	
C_{I} ⁽³⁾	Digital input capacitance	SEL1, SEL2 = 0 V , 1.8 V or V_{CC} $f = 1\text{ MHz}$		8		pF	
Protection and Detection							
$V_{\text{OVP_TH}}$	OVP positive threshold		5.55	5.8	6.0	V	
$V_{\text{OVP_HYST}}$ ⁽³⁾	OVP threshold hysteresis		40	100	300	mV	

(2) Not tested on COM1/2 pins for DGS package due to the absence of OE pin

(3) Specified by design, not tested in production.

Electrical Characteristics (continued)

$T_A = -40^{\circ}\text{C}$ to $+125^{\circ}\text{C}$, $V_{CC} = 2.3\text{ V}$ to 5.5 V , $GND = 0\text{V}$, Typical values are at $V_{CC} = 3.3\text{ V}$, $T_A = 25^{\circ}\text{C}$, (unless otherwise noted)

PARAMETER		TEST CONDITIONS	MIN	TYP	MAX	UNIT
$T_{SD_HYST}^{(3)}$	Thermal Shutdown Hysteresis		3		8	$^{\circ}\text{C}$
$T_{OTD_TH}^{(3)}$	Overtemperature detection threshold		135		165	$^{\circ}\text{C}$
$V_{CLAMP_V}^{(3)}$	Maximum voltage to appear on NC1/2 and NO1/2 pins during OVP scenario	$V_{COM1/2} = 0$ to 18 V t_{RISE} and $t_{FALL}(10\% \text{ to } 90\%) = 100\text{ ns}$ $R_L = \text{Open}$ Switch on or off $\overline{OE} = 0\text{ V}$	0		9.6	V
		$V_{COM1/2} = 0$ to 18 V t_{RISE} and $t_{FALL}(10\% \text{ to } 90\%) = 100\text{ ns}$ $R_L = 50\Omega$ Switch on or off $\overline{OE} = 0\text{ V}$	0		9.0	V
$t_{EN_OVP}^{(3)}$	OVP enable time	$R_{PU} = 10\text{ k}\Omega$ to $V_{CC} (\overline{FLT})$ $C_L = 35\text{ pF}$ Refer to OVP Timing Diagram Figure		0.6	3	μs
$t_{REC_OVP}^{(3)}$	OVP recovery time	$R_{PU} = 10\text{ k}\Omega$ to $V_{CC} (\overline{FLT})$ $C_L = 35\text{ pF}$ Refer to OVP Timing Diagram Figure		1.5	5	μs

6.6 Dynamic Characteristics

$T_A = -40^\circ\text{C}$ to $+125^\circ\text{C}$, $V_{CC} = 2.3\text{ V}$ to 5.5 V , $\text{GND} = 0\text{ V}$, Typical values are at $V_{CC} = 3.3\text{ V}$, $T_A = 25^\circ\text{C}$, (unless otherwise noted)

PARAMETER ⁽¹⁾		TEST CONDITIONS	MIN	TYP	MAX	UNIT	
C_{OFF}	COM1, COM2 off capacitance	$V_{\text{COM}1/2} = 0$ or 3.3 V , $\text{OE} = V_{\text{CC}}$ $f = 240\text{ MHz}$	Switch OFF	1.2	4.0	6.2	pF
	NC1, NO1, NC2, NO2 off capacitance	$V_{\text{COM}1/2} = 0$ or 3.3 V , $\text{OE} = V_{\text{CC}}$ or $\text{OE} = 0\text{ V}$ with SEL1, SEL2 (switch not selected) $f = 240\text{ MHz}$	Switch OFF or not selected	1.2	4.0	6.2	pF
C_{ON}	COM1, COM2, NC1, NO1, NC2, NO2 on capacitance	$V_{\text{COM}1/2} = 0$ or 3.3 V , $f = 240\text{ MHz}$	Switch ON	1.4	4.0	6.2	pF
O_{ISO}	Differential off isolation	$R_L = 50\ \Omega$ $C_L = 5\text{ pF}$ $f = 100\text{ kHz}$ Refer to Off Isolation Figure	Switch OFF		-80		dB
		$R_L = 50\ \Omega$ $C_L = 5\text{ pF}$ $f = 240\text{ MHz}$ Refer to Off Isolation Figure	Switch OFF		-22		dB
X_{TALK}	Channel to Channel crosstalk	$R_L = 50\ \Omega$ $C_L = 5\text{ pF}$ $f = 100\text{ kHz}$ Refer to Crosstalk Figure	Switch ON		-90		dB
BW	Bandwidth	$R_L = 50\ \Omega$; Refer to BW and Insertion Loss Figure	Switch ON		1.2		GHz
I_{LOSS}	Insertion loss	$R_L = 50\ \Omega$ $f = \text{TBD MHz}$; Refer to BW and Insertion Loss Figure	Switch ON		-0.8		dB

(1) Specified by design, not tested in production.

6.7 Timing Requirements

$T_A = -40^\circ\text{C}$ to $+125^\circ\text{C}$, $V_{CC} = 2.3\text{ V}$ to 5.5 V , $\text{GND} = 0\text{ V}$, Typical values are at $V_{CC} = 3.3\text{ V}$, $T_A = 25^\circ\text{C}$, (unless otherwise noted)

PARAMETER ⁽¹⁾		TEST CONDITIONS	MIN	NOM	MAX	UNIT
t_{switch}	Switching time between channels (SEL1, SEL2 to output)	$V_{\text{NC}} = 0.8\text{ V}$ Refer to Tswitch Timing Figure		0.9	1	μs
t_{on}	Device turn on time ($\overline{\text{OE}}$ to output)	$V_{\text{NC}} = 0.8\text{ V}$ Refer to Ton and Toff Figure		200	250	μs
t_{off}	Device turn off time ($\overline{\text{OE}}$ to output)	$V_{\text{NC}} = 0.8\text{ V}$ Refer to Ton and Toff Figure	$R_L = 50\ \Omega$, $C_L = 5\text{ pF}$, $V_{\text{CC}} = 2.3\text{ V}$ to 5.5 V	1	10	μs
$t_{\text{off_Vcc}}$	Device turn off time V_{CC} to Switch off	$V_{\text{NC}} = 0.8\text{ V}$ Refer to Ton and Toff Figure Ramp rate $V_{\text{CC}} = 2.3\text{ V}$ to 0 V $250\ \mu\text{s}$			250	μs
$t_{\text{SK(P)}}$	Skew of opposite transitions of same output (between COM1 and COM2) ⁽¹⁾	$V_{\text{COM}1/2} = V_{\text{CC}}$ Refer to Tsk Figure	$R_L = 50\ \Omega$, $C_L = 1\text{ pF}$, $V_{\text{CC}} = 2.3\text{ V}$ to 5.5 V	9	50	ps
t_{pd}	Propagation delay ⁽¹⁾	$V_{\text{COM}1/2} = V_{\text{CC}}$ Refer to Tpd Figure	$R_L = 50\ \Omega$, $C_L = 5\text{ pF}$, $V_{\text{CC}} = 2.3\text{ V}$ to 5.5 V	130	200	ps

(1) Specified by design, not tested in production.

6.8 Typical Characteristics

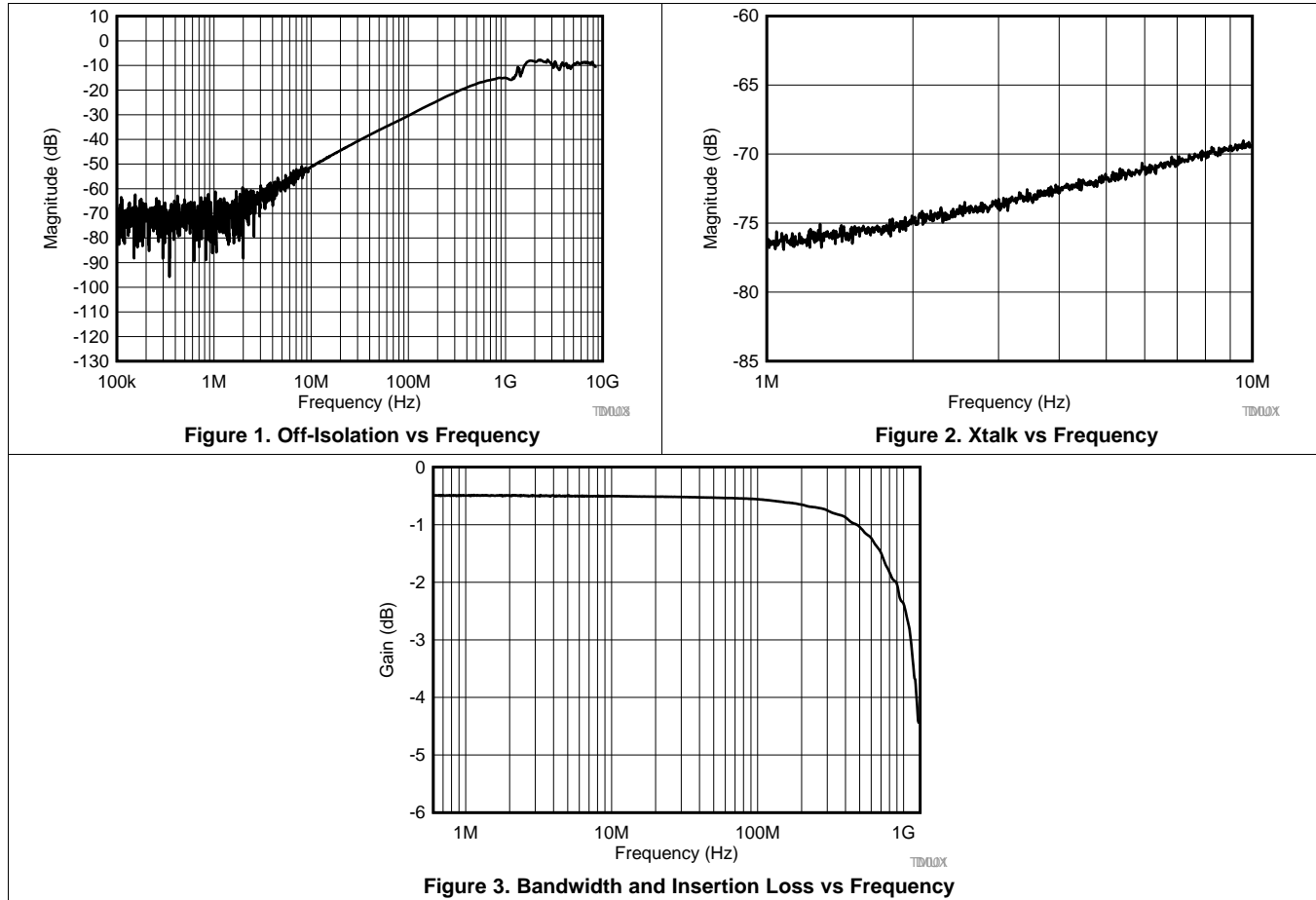

7 Parameter Measurement Information

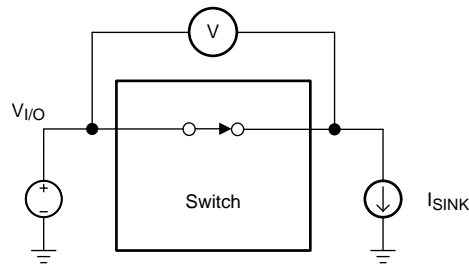

Channel ON, $R_{ON} = V/I_{SINK}$

Figure 4. ON-State Resistance (R_{ON})

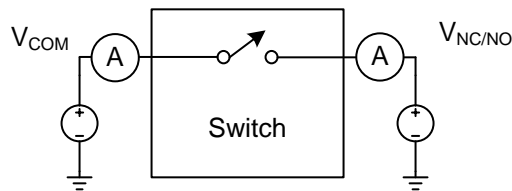

Figure 5. Off Leakage

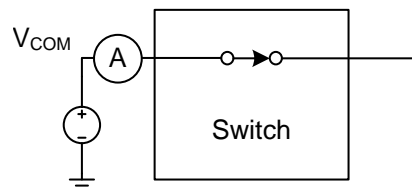
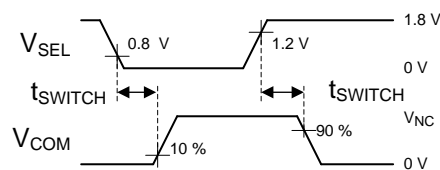
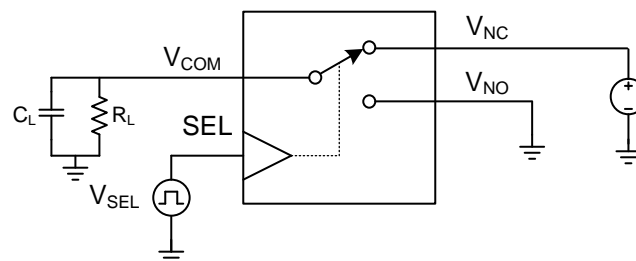

Figure 6. On Leakage



- (1) All input pulses are supplied by generators having the following characteristics: $PRR \leq 10$ MHz, $Z_O = 50 \Omega$, $t_r < 500$ ps, $t_f < 500$ ps.
- (2) C_L includes probe and jig capacitance.

Figure 7. t_{SWITCH} Timing

Parameter Measurement Information (continued)

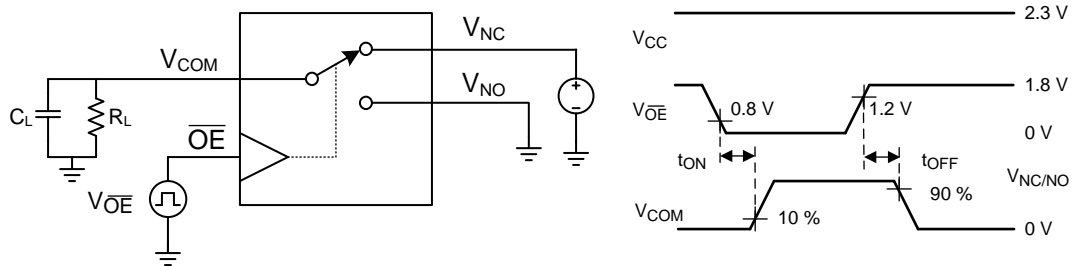

- (1) All input pulses are supplied by generators having the following characteristics: $PRR \leq 10 \text{ MHz}$, $Z_O = 50 \Omega$, $t_r < 500 \text{ ps}$, $t_f < 500 \text{ ps}$.
- (2) C_L includes probe and jig capacitance.

Figure 8. t_{ON} , t_{OFF} for \overline{OE}

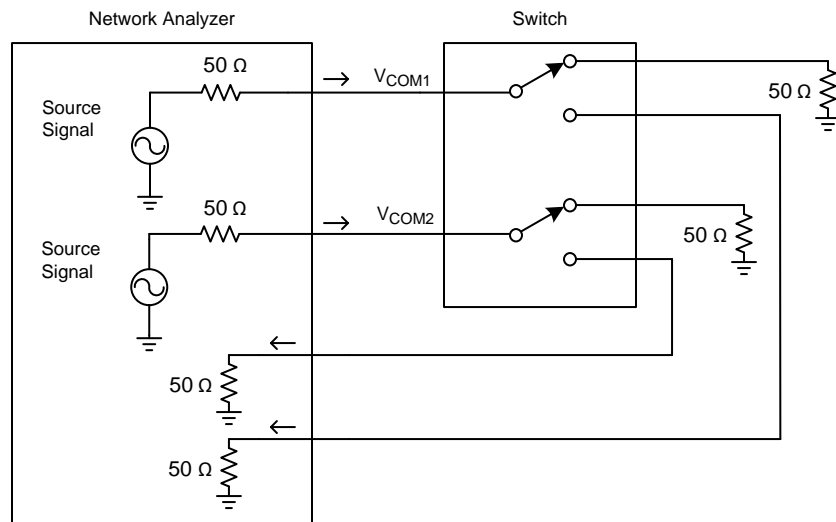

Figure 9. Off Isolation

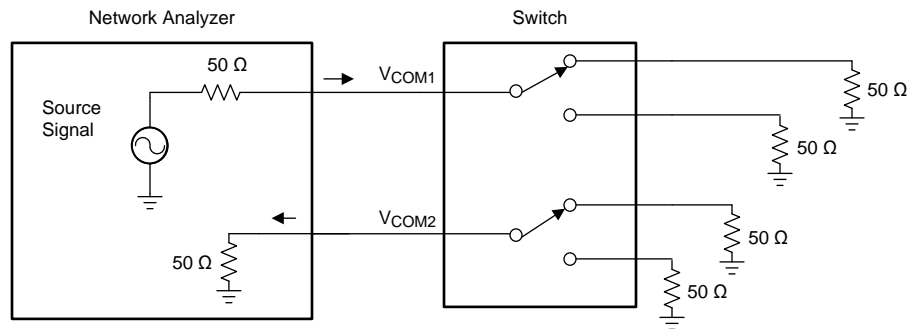

Figure 10. Cross Talk

Parameter Measurement Information (continued)

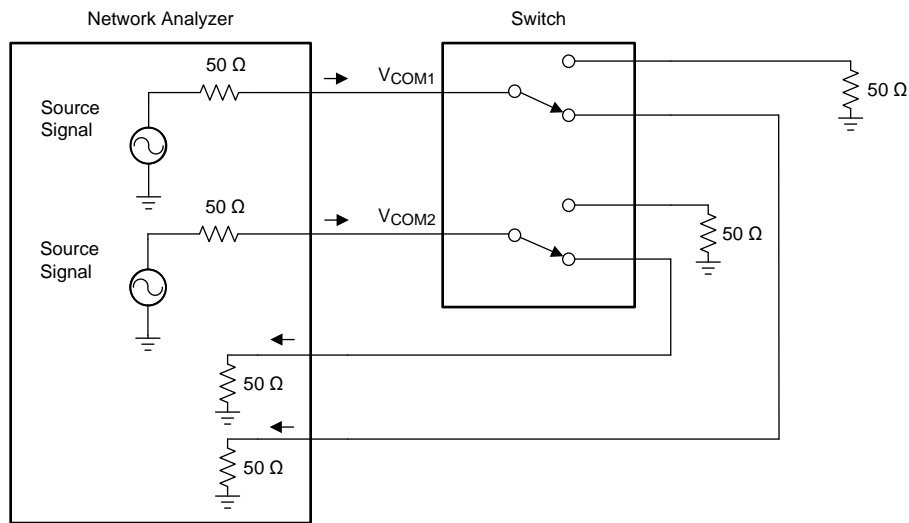

Figure 11. BW and Insertion Loss

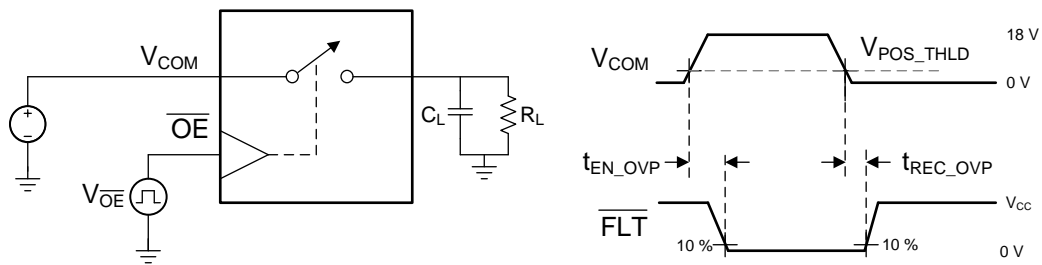
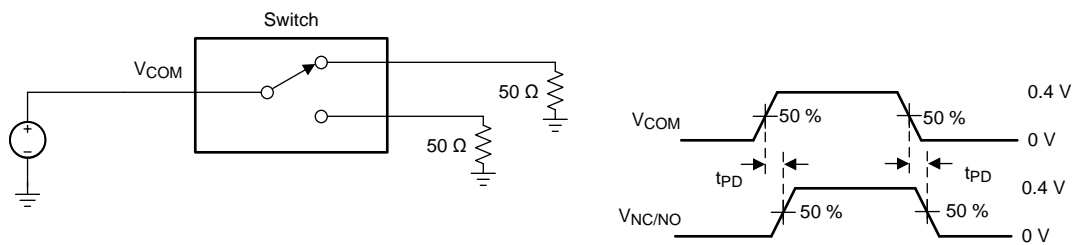

Figure 12. t_{EN_OVP} and t_{DIS_OVP} Timing Diagram



- (1) All input pulses are supplied by generators having the following characteristics: $PRR \leq 10 \text{ MHz}$, $Z_O = 50 \Omega$, $t_r < 500 \text{ ps}$, $t_f < 500 \text{ ps}$.
- (2) C_L includes probe and jig capacitance.

Figure 13. t_{PD}

Parameter Measurement Information (continued)

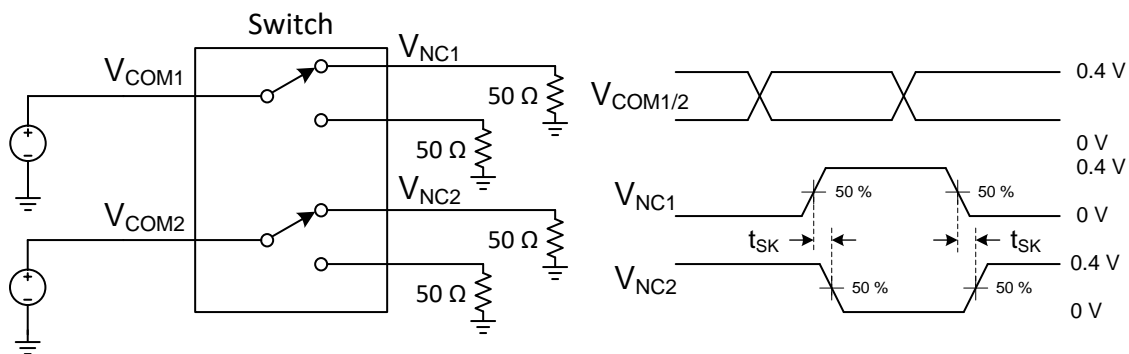

- (1) All input pulses are supplied by generators having the following characteristics: $PRR \leq 10 \text{ MHz}$, $Z_O = 50 \Omega$, $t_r < 500 \text{ ps}$, $t_f < 500 \text{ ps}$.
- (2) C_L includes probe and jig capacitance.

Figure 14. t_{SK}

8 Detailed Description

8.1 Overview

The TMUX1072 is a high speed, 2-channel 2:1 analog switch with overvoltage protection. The device is bidirectional and can be used as a dual 2:1 or 1:2 switch, but OVP only applies to the COM pins. The device also contains a fault indicator pin which can signal to the system of either an over voltage or over temperature event.

The device maintains excellent signal integrity through the optimization of both R_{ON} and BW while protecting the system with up to 18 V OVP protection. The OVP implementation is designed to protect sensitive system components behind the switch that cannot survive fault conditions.

8.2 Functional Block Diagram

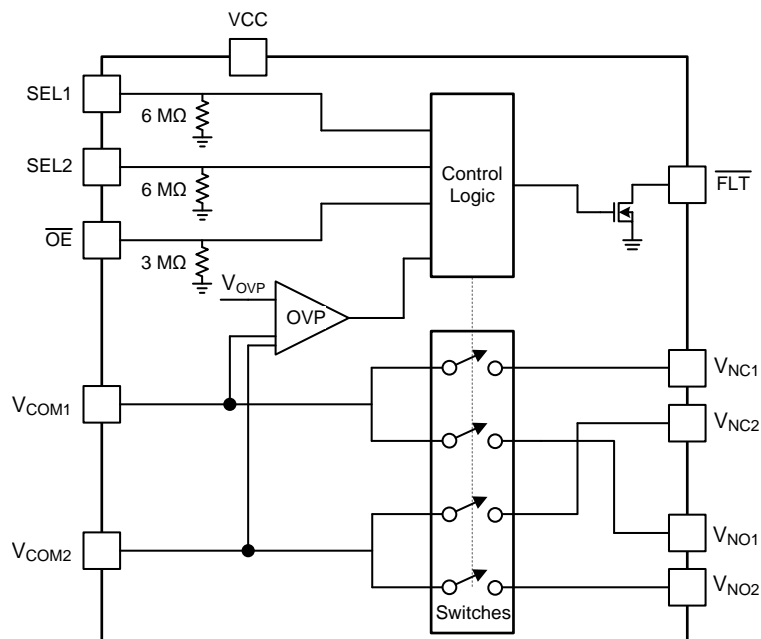

8.3 Feature Description

8.3.1 Powered-off Protection

When the TMUX1072 is powered off the I/Os of the device remain in a high-Z state. The crosstalk, off-isolation, and leakage remain within the [Electrical Specifications](#)

This prevents errant voltages from reaching the rest of the system and maintains isolation when the system is powering up.

8.3.2 Overvoltage Detection

When a voltage on the COM pin exceeds the V_{OVP_TH} , the open drain output \overline{FLT} pin pulls the pin low to indicate an overvoltage event has been detected. The open drain output will release the \overline{FLT} pin when the voltage on the COM pin returns below the V_{OVP_TH} .

8.3.3 Overtemperature Detection

When the junction temperature of the device exceeds the overtemperature detection threshold T_{OTD_TH} , the open drain output \overline{FLT} pin pulls the pin low to indicate an overtemperature event has been detected. The open drain output releases the \overline{FLT} pin when the junction temperature returns below the T_{OTD_TH} .

8.3.4 Overvoltage Protection

The OVP of the TMUX1072 is designed to protect the system from overvoltage conditions up to 18 V on the COM1 and COM2 pins. This protection is valid even if $V_{CC} = 0V$. [Figure 15](#) depicts an event where up to 18 V could appear on COM1 and COM2 that could pass through the device and damage components behind the device.

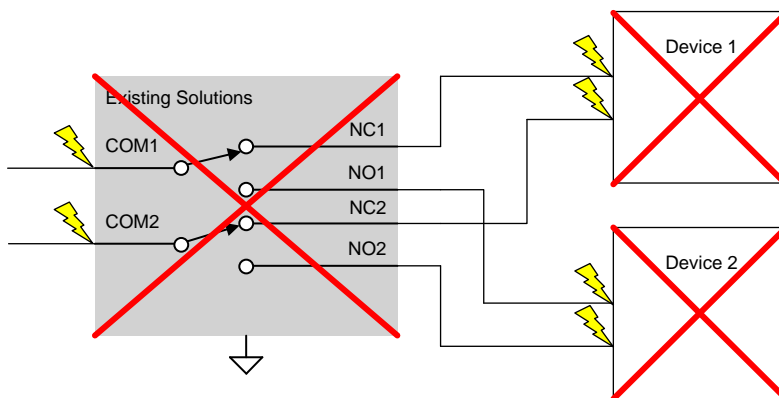

Figure 15. Existing Solution Being Damaged by a Short, 18 V

The TMUX1072 opens the switches and protect the rest of the system by blocking the 18 V as depicted in [Figure 16](#).

Feature Description (continued)

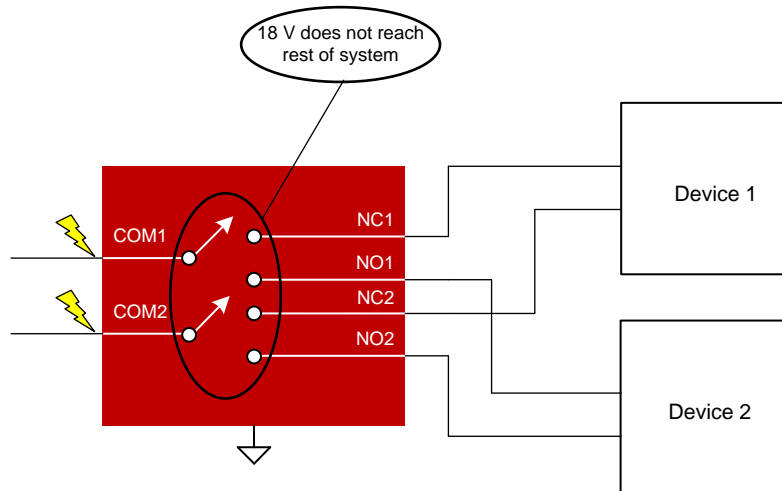

Figure 16. Protecting During a 18-V Short

Figure 17 is a waveform showing the voltage on the pins during an overvoltage scenario.

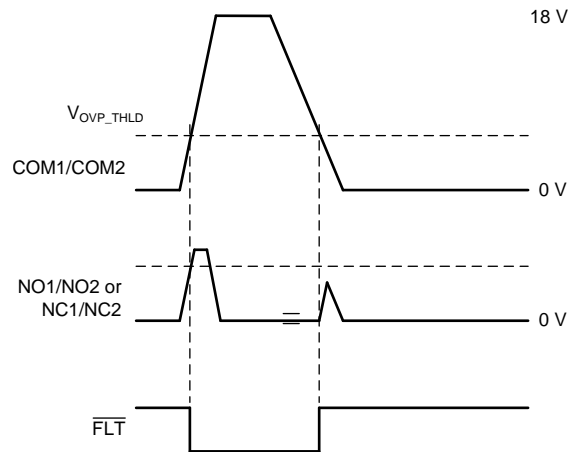

Figure 17. Overvoltage Protection Waveform, 18 V

8.4 Device Functional Modes

8.4.1 Pin Functions

Table 1. Function Table

\overline{OE}	SEL1	SEL2	COM1 Connection	COM2 Connection
H	X	X	High-Z	High-Z
L	L	L	COM1 to NC1	COM2 to NC2
L	L	H	COM1 to NC1	COM2 to NO2
L	H	L	COM1 to NO1	COM2 to NC2
L	H	H	COM1 to NO1	COM2 to NO2

9 Application and Implementation

NOTE

Information in the following applications sections is not part of the TI component specification, and TI does not warrant its accuracy or completeness. TI's customers are responsible for determining suitability of components for their purposes. Customers should validate and test their design implementation to confirm system functionality.

9.1 Application Information

There are many applications in which processors and microcontrollers have a limited number of I/Os. This IC can effectively expand the limited number of I/Os by switching between multiple signal paths in order to interface them to a single processor or microcontroller. The device can also be used to connect a single microcontroller to two signal paths. With independent control of the two switches using SEL1 and SEL2, TMUX1072 can be used to cross switch single ended signals.

9.2 Typical Application

The TMUX1072 is used to switch signals between the high speed signal paths that may be exposed to a connector or near a bus which could experience an overvoltage condition. The TMUX1072 has internal pull-down resistors on SEL1, SEL2, and OE. The pull-down on SEL1 and SEL2 pins ensure the NC1/NC2 channel is selected by default. The pull-down on OE enables the switch when power is applied.

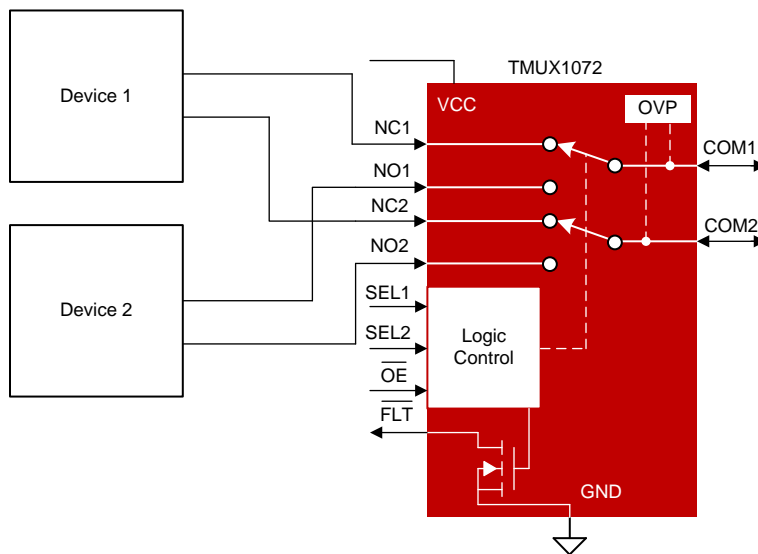

Figure 18. Typical TMUX1072 Application

9.2.1 Design Requirements

The TMUX1072 has internal pull-down resistors on SEL1, SEL2, and OE, so no external resistors are required on the logic pins. The internal pull-down resistor on SEL1 and SEL2 pins ensures the NC1 and NC2 channels are selected by default. The internal pull-down resistor on OE enables the switch when power is applied to VCC.

The FLT indicator output pin is an open drain output that will require an external pull-up resistor for the overvoltage and overtemperature condition to be detected. If feature is unused, FLT pin may be left floating or connected to ground.

9.2.2 Detailed Design Procedure

The TMUX1072 can be properly operated without any external components. However, TI recommends that unused signal pins must be connected to ground through a 50-Ω resistor to prevent signal reflections back into the device. TI does recommend a 100-nF bypass capacitor placed close to TMUX1072 VCC pin.

Typical Application (continued)

9.2.3 Application Curves

Bandwidth is defined as the range of frequencies that are attenuated by less than 3 dB when the input is applied to the source pin of an on-channel, and the output is measured at the drain pin of the TMUX1072. [Figure 19](#) shows the bandwidth of TMUX1072.

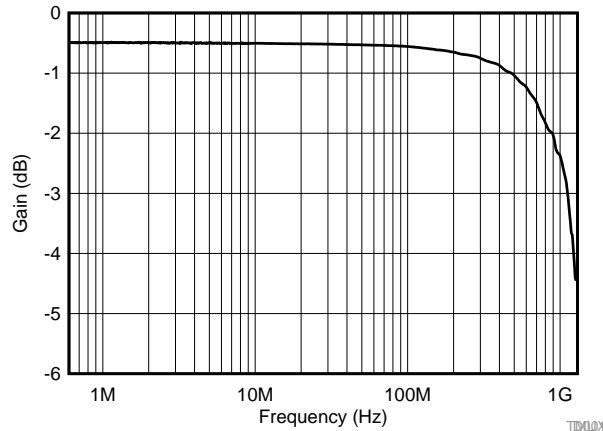

Figure 19. Bandwidth and Insertion Loss vs Frequency

10 Power Supply Recommendations

Power to the device is supplied through the VCC pin. TI recommends placing a 100-nF bypass capacitor as close to the supply pin VCC as possible to help smooth out lower frequency noise to provide better load regulation across the frequency spectrum.

11 Layout

11.1 Layout Guidelines

1. Place supply bypass capacitors as close to VCC pin as possible and avoid placing the bypass caps near the signal traces.
2. The high-speed traces should always be of equal length and must be no more than 4 inches; otherwise, the eye diagram performance may be degraded.
3. Route the high-speed signals using a minimum of vias and corners which will reduce signal reflections and impedance changes. When a via must be used, increase the clearance size around it to minimize its capacitance. Each via introduces discontinuities in the transmission line of the signal and increases the chance of picking up interference from the other layers of the board. Be careful when designing test points on twisted pair lines; through-hole pins are not recommended.
4. When it becomes necessary to turn 90°, use two 45° turns or an arc instead of making a single 90° turn. This reduces reflections on the signal traces by minimizing impedance discontinuities.
5. Do not route signal traces under or near crystals, oscillators, clock signal generators, switching regulators, mounting holes, magnetic devices, or IC's that use or duplicate clock signals.
6. Avoid stubs on the high-speed signals because they cause signal reflections.
7. Route all high-speed signal traces over continuous planes (VCC or GND), with no interruptions.
8. Avoid crossing over anti-etch, commonly found with plane splits.
9. For high frequency systems, a printed circuit board with at least four layers is recommended: two signal layers separated by a ground layer and a power layer. The majority of signal traces should run on a single layer, preferably Signal 1. Immediately next to this layer should be the GND plane, which is solid with no cuts. Avoid running signal traces across a split in the ground or power plane. When running across split planes is unavoidable, sufficient decoupling must be used. Minimizing the number of signal vias reduces EMI by reducing inductance at high frequencies. For more information on layout guidelines, see High Speed Layout Guidelines (SCAA082)

11.2 Layout Example

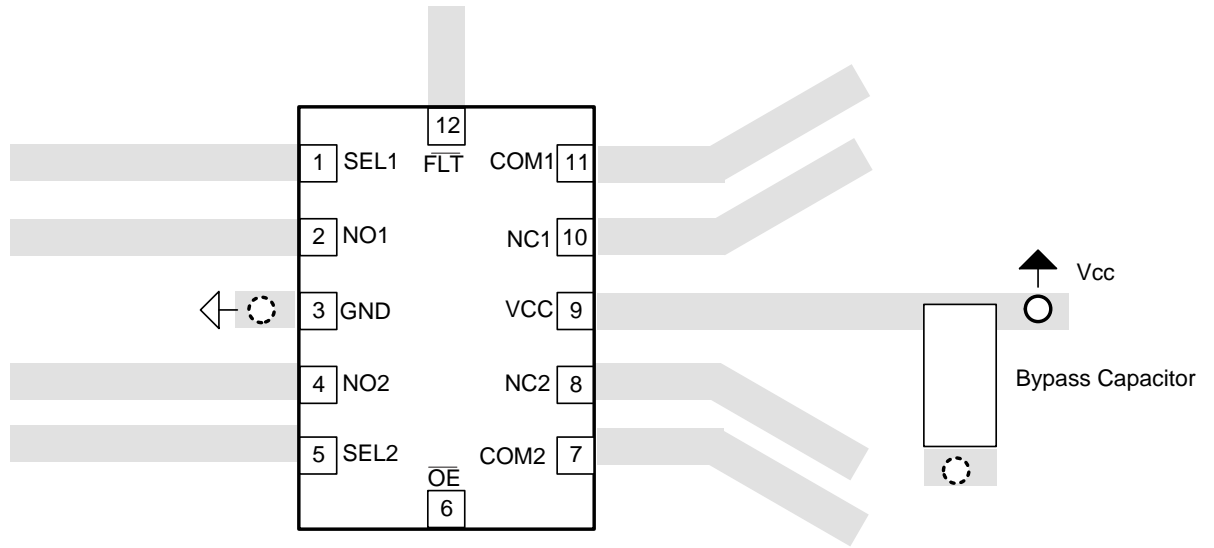
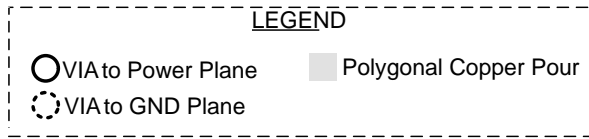

Not to scale

Figure 20. Layout Example

12 Device and Documentation Support

12.1 Documentation Support

12.1.1 Related Documentation

For related documentation see the following:

- [High-Speed Layout Guidelines Application Report](#)
- [High-Speed Interface Layout Guidelines](#)

12.2 Receiving Notification of Documentation Updates

To receive notification of documentation updates, navigate to the device product folder on ti.com. In the upper right corner, click on *Alert me* to register and receive a weekly digest of any product information that has changed. For change details, review the revision history included in any revised document.

12.3 Community Resources

The following links connect to TI community resources. Linked contents are provided "AS IS" by the respective contributors. They do not constitute TI specifications and do not necessarily reflect TI's views; see TI's [Terms of Use](#).

TI E2E™ Online Community *TI's Engineer-to-Engineer (E2E) Community*. Created to foster collaboration among engineers. At e2e.ti.com, you can ask questions, share knowledge, explore ideas and help solve problems with fellow engineers.

Design Support *TI's Design Support* Quickly find helpful E2E forums along with design support tools and contact information for technical support.

12.4 Trademarks

E2E is a trademark of Texas Instruments.

12.5 Electrostatic Discharge Caution



This integrated circuit can be damaged by ESD. Texas Instruments recommends that all integrated circuits be handled with appropriate precautions. Failure to observe proper handling and installation procedures can cause damage.

ESD damage can range from subtle performance degradation to complete device failure. Precision integrated circuits may be more susceptible to damage because very small parametric changes could cause the device not to meet its published specifications.

12.6 Glossary

SLYZ022 — *TI Glossary*.

This glossary lists and explains terms, acronyms, and definitions.

13 Mechanical, Packaging, and Orderable Information

The following pages include mechanical, packaging, and orderable information. This information is the most current data available for the designated devices. This data is subject to change without notice and revision of this document. For browser-based versions of this data sheet, refer to the left-hand navigation.

PACKAGING INFORMATION

Orderable Device	Status (1)	Package Type	Package Drawing	Pins	Package Qty	Eco Plan (2)	Lead finish/ Ball material (6)	MSL Peak Temp (3)	Op Temp (°C)	Device Marking (4/5)	Samples
TMUX1072DGSR	ACTIVE	VSSOP	DGS	10	2500	RoHS & Green	NIPDAUAG SN	Level-1-260C-UNLIM	-40 to 125	1A9	Samples
TMUX1072RUTR	ACTIVE	UQFN	RUT	12	3000	RoHS & Green	NIPDAUAG	Level-1-260C-UNLIM	-40 to 125	1BU	Samples

(1) The marketing status values are defined as follows:

ACTIVE: Product device recommended for new designs.

LIFEBUY: TI has announced that the device will be discontinued, and a lifetime-buy period is in effect.

NRND: Not recommended for new designs. Device is in production to support existing customers, but TI does not recommend using this part in a new design.

PREVIEW: Device has been announced but is not in production. Samples may or may not be available.

OBSOLETE: TI has discontinued the production of the device.

(2) **RoHS:** TI defines "RoHS" to mean semiconductor products that are compliant with the current EU RoHS requirements for all 10 RoHS substances, including the requirement that RoHS substance do not exceed 0.1% by weight in homogeneous materials. Where designed to be soldered at high temperatures, "RoHS" products are suitable for use in specified lead-free processes. TI may reference these types of products as "Pb-Free".

RoHS Exempt: TI defines "RoHS Exempt" to mean products that contain lead but are compliant with EU RoHS pursuant to a specific EU RoHS exemption.

Green: TI defines "Green" to mean the content of Chlorine (Cl) and Bromine (Br) based flame retardants meet JS709B low halogen requirements of <=1000ppm threshold. Antimony trioxide based flame retardants must also meet the <=1000ppm threshold requirement.

(3) MSL, Peak Temp. - The Moisture Sensitivity Level rating according to the JEDEC industry standard classifications, and peak solder temperature.

(4) There may be additional marking, which relates to the logo, the lot trace code information, or the environmental category on the device.

(5) Multiple Device Markings will be inside parentheses. Only one Device Marking contained in parentheses and separated by a "~" will appear on a device. If a line is indented then it is a continuation of the previous line and the two combined represent the entire Device Marking for that device.

(6) Lead finish/Ball material - Orderable Devices may have multiple material finish options. Finish options are separated by a vertical ruled line. Lead finish/Ball material values may wrap to two lines if the finish value exceeds the maximum column width.

Important Information and Disclaimer:The information provided on this page represents TI's knowledge and belief as of the date that it is provided. TI bases its knowledge and belief on information provided by third parties, and makes no representation or warranty as to the accuracy of such information. Efforts are underway to better integrate information from third parties. TI has taken and continues to take reasonable steps to provide representative and accurate information but may not have conducted destructive testing or chemical analysis on incoming materials and chemicals. TI and TI suppliers consider certain information to be proprietary, and thus CAS numbers and other limited information may not be available for release.

In no event shall TI's liability arising out of such information exceed the total purchase price of the TI part(s) at issue in this document sold by TI to Customer on an annual basis.

TAPE AND REEL INFORMATION

QUADRANT ASSIGNMENTS FOR PIN 1 ORIENTATION IN TAPE

*All dimensions are nominal

Device	Package Type	Package Drawing	Pins	SPQ	Reel Diameter (mm)	Reel Width W1 (mm)	A0 (mm)	B0 (mm)	K0 (mm)	P1 (mm)	W (mm)	Pin1 Quadrant
TMUX1072DGSR	VSSOP	DGS	10	2500	330.0	12.4	5.25	3.35	1.25	8.0	12.0	Q1
TMUX1072RUTR	UQFN	RUT	12	3000	180.0	9.5	1.9	2.2	0.7	4.0	8.0	Q1

TAPE AND REEL BOX DIMENSIONS



*All dimensions are nominal

Device	Package Type	Package Drawing	Pins	SPQ	Length (mm)	Width (mm)	Height (mm)
TMUX1072DGSR	VSSOP	DGS	10	2500	366.0	364.0	50.0
TMUX1072RUTR	UQFN	RUT	12	3000	189.0	185.0	36.0

DGS0010A



PACKAGE OUTLINE

VSSOP - 1.1 mm max height

SMALL OUTLINE PACKAGE



4221984/A 05/2015

NOTES:

1. All linear dimensions are in millimeters. Any dimensions in parenthesis are for reference only. Dimensioning and tolerancing per ASME Y14.5M.
2. This drawing is subject to change without notice.
3. This dimension does not include mold flash, protrusions, or gate burrs. Mold flash, protrusions, or gate burrs shall not exceed 0.15 mm per side.
4. This dimension does not include interlead flash. Interlead flash shall not exceed 0.25 mm per side.
5. Reference JEDEC registration MO-187, variation BA.

EXAMPLE BOARD LAYOUT

DGS0010A

VSSOP - 1.1 mm max height

SMALL OUTLINE PACKAGE

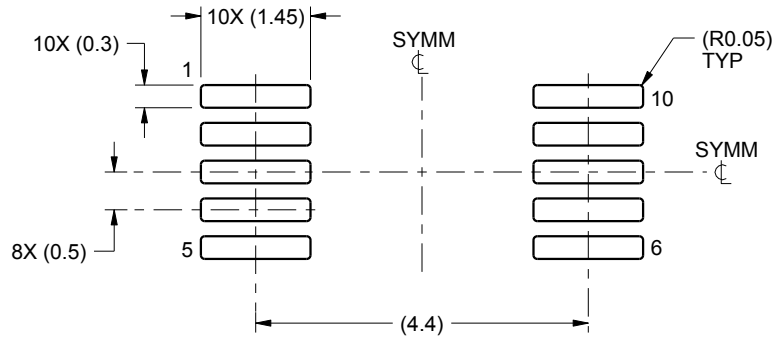

LAND PATTERN EXAMPLE
SCALE:10X

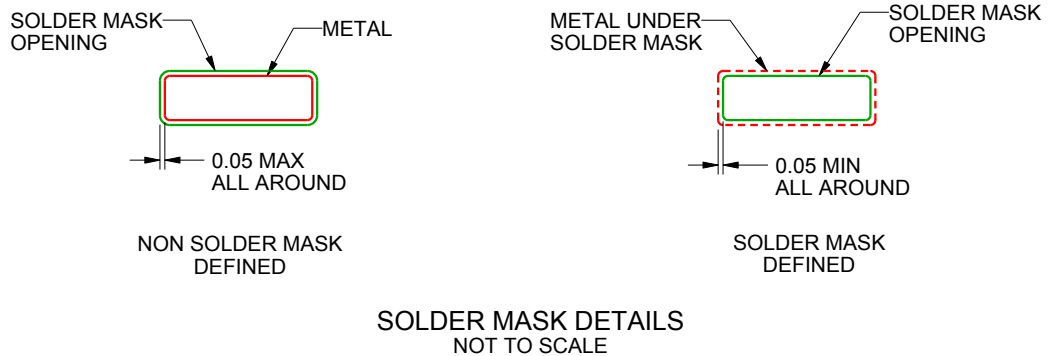

SOLDER MASK DETAILS
NOT TO SCALE

4221984/A 05/2015

NOTES: (continued)

6. Publication IPC-7351 may have alternate designs.
7. Solder mask tolerances between and around signal pads can vary based on board fabrication site.

EXAMPLE STENCIL DESIGN

DGS0010A

VSSOP - 1.1 mm max height

SMALL OUTLINE PACKAGE



SOLDER PASTE EXAMPLE
BASED ON 0.125 mm THICK STENCIL
SCALE:10X

4221984/A 05/2015

NOTES: (continued)

8. Laser cutting apertures with trapezoidal walls and rounded corners may offer better paste release. IPC-7525 may have alternate design recommendations.
9. Board assembly site may have different recommendations for stencil design.

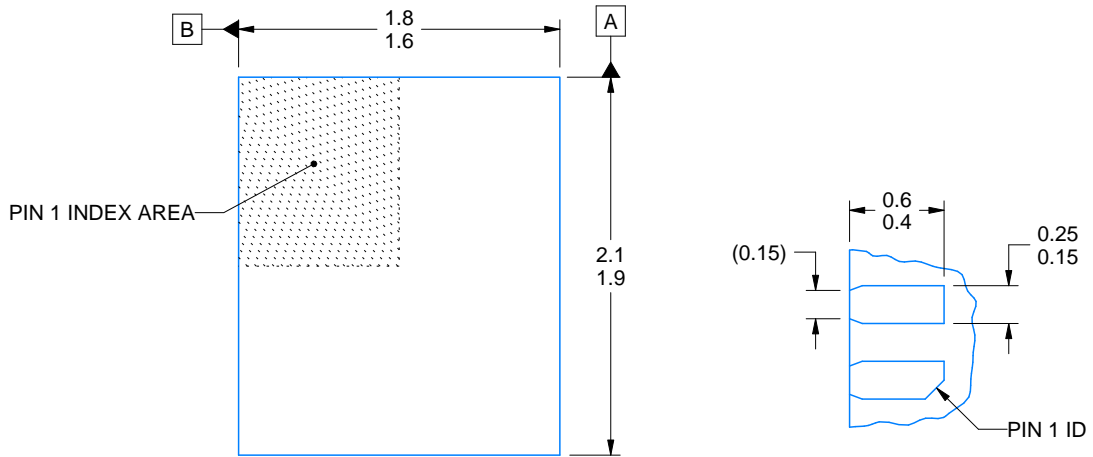
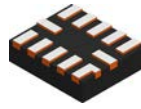

OPTIONAL TERMINAL & PIN 1 ID

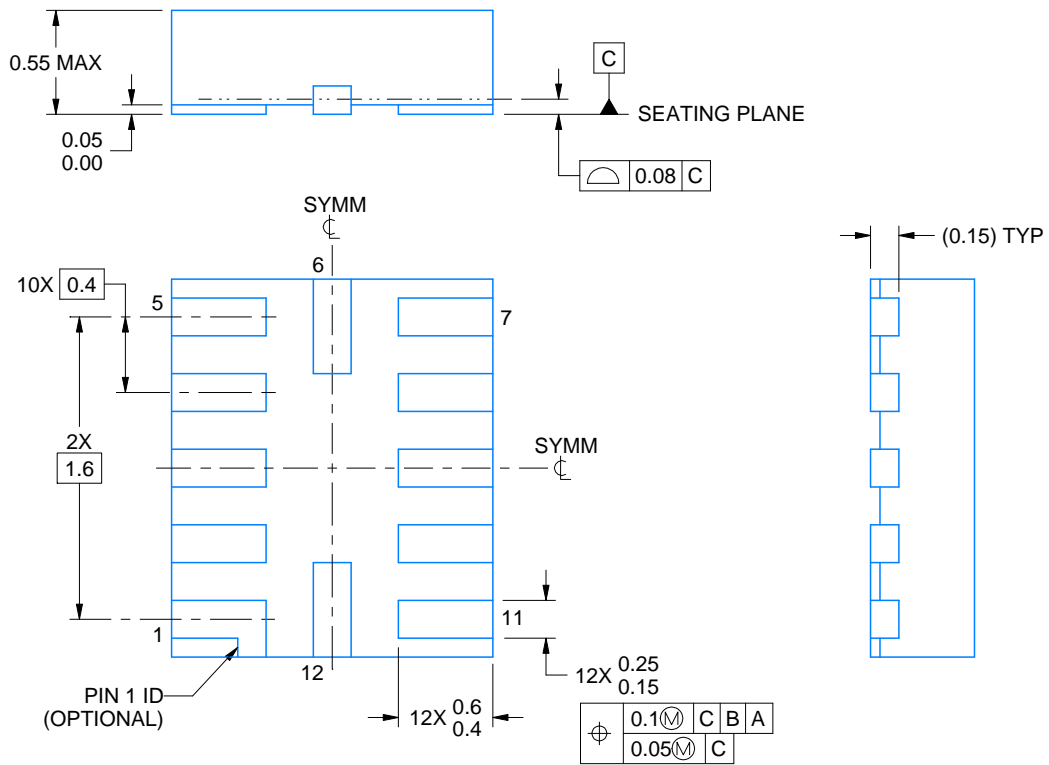

4220310/A 11/2016

NOTES:

1. All linear dimensions are in millimeters. Any dimensions in parenthesis are for reference only. Dimensioning and tolerancing per ASME Y14.5M.
2. This drawing is subject to change without notice.

EXAMPLE BOARD LAYOUT

RUT0012A

UQFN - 0.55 mm max height

PLASTIC QUAD FLATPACK - NO LEAD

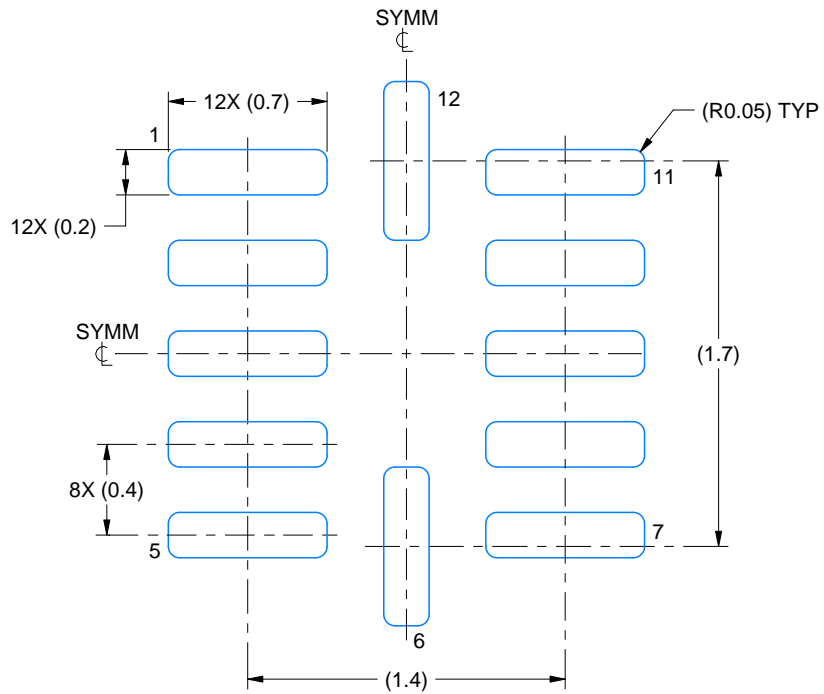

LAND PATTERN EXAMPLE
SCALE:30X

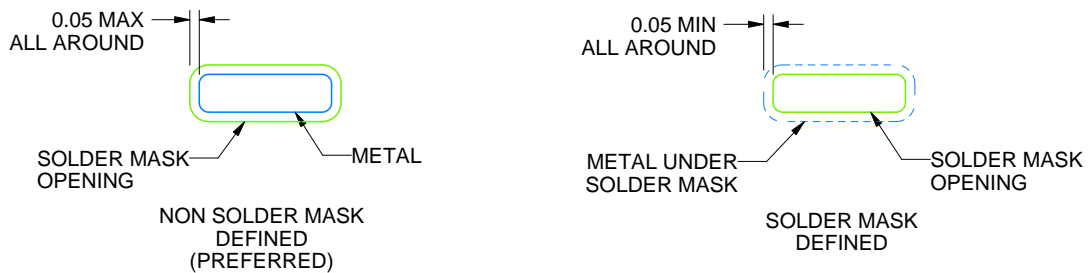

SOLDER MASK DETAILS

4220310/A 11/2016

NOTES: (continued)

3. For more information, see Texas Instruments literature number SLUA271 (www.ti.com/lit/sluea271).

EXAMPLE STENCIL DESIGN

RUT0012A

UQFN - 0.55 mm max height

PLASTIC QUAD FLATPACK - NO LEAD

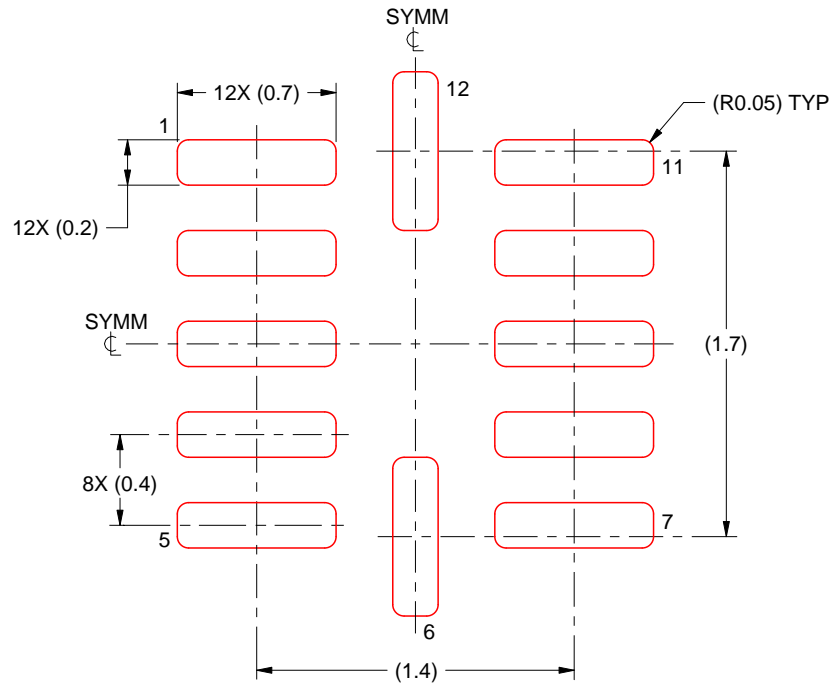

SOLDER PASTE EXAMPLE
BASED ON 0.1 mm THICK STENCIL
SCALE: 30X

4220310/A 11/2016

NOTES: (continued)

4. Laser cutting apertures with trapezoidal walls and rounded corners may offer better paste release. IPC-7525 may have alternate design recommendations.

IMPORTANT NOTICE AND DISCLAIMER

TI PROVIDES TECHNICAL AND RELIABILITY DATA (INCLUDING DATA SHEETS), DESIGN RESOURCES (INCLUDING REFERENCE DESIGNS), APPLICATION OR OTHER DESIGN ADVICE, WEB TOOLS, SAFETY INFORMATION, AND OTHER RESOURCES "AS IS" AND WITH ALL FAULTS, AND DISCLAIMS ALL WARRANTIES, EXPRESS AND IMPLIED, INCLUDING WITHOUT LIMITATION ANY IMPLIED WARRANTIES OF MERCHANTABILITY, FITNESS FOR A PARTICULAR PURPOSE OR NON-INFRINGEMENT OF THIRD PARTY INTELLECTUAL PROPERTY RIGHTS.

These resources are intended for skilled developers designing with TI products. You are solely responsible for (1) selecting the appropriate TI products for your application, (2) designing, validating and testing your application, and (3) ensuring your application meets applicable standards, and any other safety, security, regulatory or other requirements.

These resources are subject to change without notice. TI grants you permission to use these resources only for development of an application that uses the TI products described in the resource. Other reproduction and display of these resources is prohibited. No license is granted to any other TI intellectual property right or to any third party intellectual property right. TI disclaims responsibility for, and you will fully indemnify TI and its representatives against, any claims, damages, costs, losses, and liabilities arising out of your use of these resources.

TI's products are provided subject to [TI's Terms of Sale](#) or other applicable terms available either on [ti.com](https://www.ti.com) or provided in conjunction with such TI products. TI's provision of these resources does not expand or otherwise alter TI's applicable warranties or warranty disclaimers for TI products.

TI objects to and rejects any additional or different terms you may have proposed.

Mailing Address: Texas Instruments, Post Office Box 655303, Dallas, Texas 75265
Copyright © 2024, Texas Instruments Incorporated