

TMUX1511 Low-Capacitance, 1:1 (SPST) 4-Channel, Powered-Off Protected Switch with 1.8V Logic

1 Features

- Wide Supply Range: 1.5V to 5.5V
- Low On-Capacitance: 3.3pF
- Low On-Resistance: 2Ω
- High Bandwidth: 3GHz
- -40°C to +125°C Operating Temperature
- [1.8V Logic Compatible](#)
- [Supports Input Voltage Beyond Supply](#)
- [Integrated Pull Down Resistor on Logic Pins](#)
- [Bidirectional Signal Path](#)
- [Fail-Safe Logic](#)
- [Powered-off protection](#) up to 3.6V
 - Pinout compatible to SN74CBTLV3126
 - Pinout compatible (logic variant) of SN74CBTLV3125

2 Applications

- Servers
- Wired Networking
- Wireless Infrastructure
- Data Center Switches & Routers
- PC/Notebooks
- Building Automation
- ePOS
- Motor Drives
- Appliances
- Battery-Powered Equipment
- JTAG Isolation
- SPI Isolation

3 Description

The TMUX1511 is a complementary metal-oxide semiconductor (CMOS) switch. The TMUX1511 offers 1:1 SPST switch configuration with 4 independently controlled channels. Wide operating supply of 1.5V to 5.5V allows for use in a broad array of applications from servers and communication equipment to industrial applications. The device supports [bidirectional](#) analog and digital signals on the source (Sx) and drain (Dx) pins and can pass signals above supply up to $V_{DD} \times 2$, with a maximum input/output voltage of 5.5V.

Up to 3.6V on the signal path of the TMUX1511 provides isolation when the supply voltage is removed ($V_{DD} = 0V$). Without this protection feature, switches can back-power the supply rail through an internal ESD diode and cause potential damage to the system.

[Fail-Safe Logic](#) circuitry allows voltages on the logic control pins to be applied before the supply pin, protecting the device from potential damage. All logic control inputs have [1.8V logic compatible](#) thresholds, ensuring both TTL and CMOS logic compatibility when operating in the valid supply voltage range.

Package Information

PART NUMBER	PACKAGE (1)	BODY SIZE (NOM)
TMUX1511	TSSOP (14)	5.00mm × 4.40mm
	QFN (16)	2.60mm x 1.80mm
	X2QFN (12)	1.60mm x 1.60mm

(1) For all available packages, see the package option addendum at the end of the data sheet.

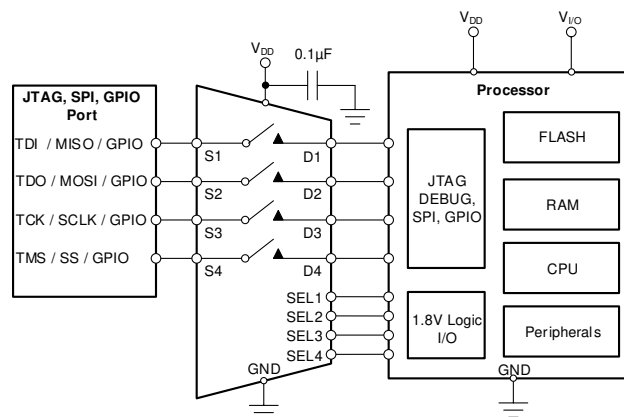

Application Example



Table of Contents

1 Features	1	6.12 Channel-to-Channel Crosstalk.....	19
2 Applications	1	6.13 Bandwidth.....	20
3 Description	1	7 Detailed Description	21
4 Pin Configuration and Functions	3	7.1 Overview.....	21
Pin Functions.....	3	7.2 Functional Block Diagram.....	21
5 Specifications	4	7.3 Feature Description.....	21
5.1 Absolute Maximum Ratings.....	4	7.4 Device Functional Modes.....	22
5.2 ESD Ratings.....	4	7.5 Truth Tables.....	22
5.3 Recommended Operating Conditions.....	4	8 Application and Implementation	23
5.4 Thermal Information.....	4	8.1 Application Information.....	23
5.5 Electrical Characteristics.....	6	8.2 Typical Application.....	23
5.6 Dynamic Characteristics.....	7	9 Power Supply Recommendations	26
5.7 Timing Requirements.....	7	10 Layout	27
5.8 Typical Characteristics.....	8	10.1 Layout Guidelines.....	27
6 Parameter Measurement Information	13	10.2 Layout Example.....	28
6.1 On-Resistance.....	13	11 Device and Documentation Support	29
6.2 Off-Leakage Current.....	13	11.1 Third-Party Products Disclaimer.....	29
6.3 On-Leakage Current.....	14	11.2 Documentation Support.....	29
6.4 IPOFF Leakage Current.....	14	11.3 Receiving Notification of Documentation Updates..	29
6.5 Transition Time.....	15	11.4 Support Resources.....	29
6.6 $T_{ON(VDD)}$ and $T_{OFF(VDD)}$ Time.....	15	11.5 Trademarks.....	29
6.7 Propagation Delay.....	17	11.6 Electrostatic Discharge Caution.....	29
6.8 Skew.....	17	11.7 Glossary.....	29
6.9 Charge Injection.....	18	12 Revision History	30
6.10 Capacitance.....	18	13 Mechanical, Packaging, and Orderable Information	30
6.11 Off Isolation.....	19		

4 Pin Configuration and Functions

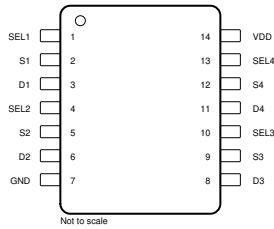

Figure 4-1. PW Package 14-Pin TSSOP Top View

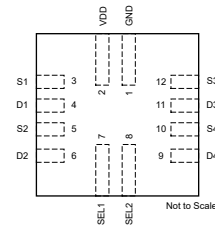

Figure 4-2. RWB Package 12-Pin X2QFN Top View

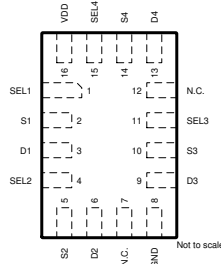

Figure 4-3. RSV Package 16-Pin QFN Top View

Pin Functions

NAME	PIN			TYPE ⁽¹⁾	DESCRIPTION
	TSSOP	UQFN	X2QFN		
SEL1	1	1	7	I	Select pin 1: controls state of switch #1 (logic low = OFF, logic high = ON). Internal 6MΩ pull-down to GND.
S1	2	2	3	I/O	Source pin 1. Can be an input or output.
D1	3	3	4	I/O	Drain pin 1. Can be an input or output.
SEL2	4	4	8	I	Select pin 2: controls state of switch #2 (logic low = OFF, logic high = ON). Internal 6MΩ pull-down to GND.
S2	5	5	5	I/O	Source pin 2. Can be an input or output.
D2	6	6	6	I/O	Drain pin 2. Can be an input or output.
N.C.	-	7	-	Not Connected	Not Connected - Can be shorted to GND or left floating
GND	7	8	1	P	Ground (0V) reference
D3	8	9	11	I/O	Drain pin 3. Can be an input or output.
S3	9	10	12	I/O	Source pin 3. Can be an input or output.
SEL3	10	11	-	I	Select pin 3: controls state of switch #3 (logic low = OFF, logic high = ON). Internal 6MΩ pull-down to GND.
N.C.	-	12	-	Not Connected	Not Connected - Can be shorted to GND or left floating
D4	11	13	9	I/O	Drain pin 4. Can be an input or output.
S4	12	14	10	I/O	Source pin 4. Can be an input or output.
SEL4	13	15	-	I	Select pin 4: controls state of switch #4 (logic low = OFF, logic high = ON). Internal 6MΩ pull-down to GND.
VDD	14	16	2	P	Positive power supply. This pin is the most positive power-supply potential. For reliable operation, connect a decoupling capacitor ranging from 0.1μF to 10μF between V _{DD} and GND.

(1) I = input, O = output, I/O = input and output, P = power

5 Specifications

5.1 Absolute Maximum Ratings

over operating free-air temperature range (unless otherwise noted)^{(1) (2) (3)}

		MIN	MAX	UNIT
V _{DD}	Supply voltage	-0.5	6	V
V _{SEL}	Logic control input pin voltage (SEL1, SEL2, SEL3, SEL4)	-0.5	6	V
I _{SEL}	Logic control input pin current (SEL1, SEL2, SEL3, SEL4)	-30	30	mA
V _S or V _D	Source or drain pin voltage	-0.5	6	V
I _S or I _D (CONT)	Source and drain pin continuous current: (S1 to S4, D1 to D4)	-25	25	mA
T _{stg}	Storage temperature	-65	150	°C
T _J	Junction temperature		150	°C

- (1) Stresses beyond those listed under *Absolute Maximum Ratings* may cause permanent damage to the device. These are stress ratings only, which do not imply functional operation of the device at these or any other conditions beyond those indicated under *Recommended Operating Conditions*. Exposure to absolute-maximum-rated conditions for extended periods may affect device reliability.
- (2) The algebraic convention, whereby the most negative value is a minimum and the most positive value is a maximum.
- (3) All voltages are with respect to ground, unless otherwise specified.

5.2 ESD Ratings

			VALUE	UNIT
V _(ESD)	Electrostatic discharge	Human body model (HBM), per ANSI/ESDA/ JEDEC JS-001 ⁽¹⁾	±2000	V
		Charged-device model (CDM), per JEDEC specification JESD22-C101 ⁽²⁾	±750	

- (1) JEDEC document JEP155 states that 500V HBM allows safe manufacturing with a standard ESD control process.
- (2) JEDEC document JEP157 states that 250V CDM allows safe manufacturing with a standard ESD control process.

5.3 Recommended Operating Conditions

		MIN	MAX	UNIT
V _{DD}	Supply voltage	1.5	5.5	V
V _S or V _D	Signal path input/output voltage (source or drain pin), V _{DD} ≥ 1.5V ⁽¹⁾	0	V _{DD} × 2	V
V _{S_off} or V _{D_off}	Signal path input/output voltage (source or drain pin), V _{DD} < 1.5V ⁽²⁾	0	3.6	V
V _{SEL}	Logic control input voltage (SELx)	0	5.5	V
T _A	Ambient temperature	-40	125	°C

- (1) Device input/output can operate up to V_{DD} × 2, with a maximum input/output voltage of 5.5V.
- (2) V_{S_off} and V_{D_off} refers to the voltage at the source or drain pins when supply is less than 1.5V.

5.4 Thermal Information

THERMAL METRIC ⁽¹⁾		DEVICE	DEVICE	DEVICE	UNIT
		PW (TSSOP)	RSV (UQFN)	RWB (X2QFN)	
		14 PINS	16 PINS	12 PINS	
R _{θJA}	Junction-to-ambient thermal resistance	129.4	141.5	166.1	°C/W
R _{θJC(top)}	Junction-to-case (top) thermal resistance	58.8	77.9	59.5	°C/W
R _{θJB}	Junction-to-board thermal resistance	72.4	67.6	103.6	°C/W
Ψ _{JT}	Junction-to-top characterization parameter	11.6	5.1	1.0	°C/W
Ψ _{JB}	Junction-to-board characterization parameter	71.9	65.5	103.4	°C/W

THERMAL METRIC ⁽¹⁾		DEVICE	DEVICE	DEVICE	UNIT
		PW (TSSOP)	RSV (UQFN)	RWB (X2QFN)	
		14 PINS	16 PINS	12 PINS	
$R_{\theta JC(bot)}$	Junction-to-case (bottom) thermal resistance	N/A	N/A	N/A	°C/W

- (1) For more information about traditional and new thermal metrics, see the [Semiconductor and IC Package Thermal Metrics](#) application report.

5.5 Electrical Characteristics

$V_{DD} = 1.5V$ to $5.5V$, $GND = 0V$, $T_A = -40^{\circ}C$ to $+125^{\circ}C$,
Typical values are at $V_{DD} = 3.3V$, $T_A = 25^{\circ}C$, (unless otherwise noted)

PARAMETER		TEST CONDITIONS	MIN	TYP	MAX	UNIT
POWER SUPPLY						
V_{DD}	Power supply voltage		1.5		5.5	V
I_{DD}	Supply current	$V_{SEL} = 0V, 1.4V$ or V_{DD} $V_S = 0V$ to $5.5V$		37	70	μA
DC CHARACTERISTICS						
R_{ON}	On-resistance	$V_S = 0V$ to $V_{DD} \cdot 2$ $V_{S(max)} = 5.5V$ $I_{SD} = 8mA$ Refer to ON-State Resistance Figure		2	4.5	Ω
ΔR_{ON}	On-resistance match between channels	$V_S = V_{DD}$ $I_{SD} = 8mA$ Refer to ON-State Resistance Figure		0.07	0.28	Ω
$R_{ON(FLAT)}$	On-resistance flatness	$V_S = 0V$ to V_{DD} $I_{SD} = 8mA$ Refer to ON-State Resistance Figure		1	1.8	Ω
I_{POFF}	Powered-off I/O pin leakage current	$V_{DD} = 0V$ $V_S = 0V$ to $3V$ $V_D = 0V$ $T_A = 25^{\circ}C$ Refer to Ipooff Leakage Figure	-10	0.01	10	nA
I_{POFF}	Powered-off I/O pin leakage current	$V_{DD} = 0V$ $V_S = 0V$ to $3.6V$ $V_D = 0V$ Refer to Ipooff Leakage Figure	-2	0.01	2	μA
$I_{S(OFF)}$ $I_{D(OFF)}$	OFF leakage current	Switch Off $V_D = 0.8 \cdot V_{DD} / 0.2 \cdot V_{DD}$ $V_S = 0.2 \cdot V_{DD} / 0.8 \cdot V_{DD}$ Refer to Off Leakage Figure	-100	0.03	100	nA
$I_{D(ON)}$ $I_{S(ON)}$	ON leakage current	Switch On $V_D = 0.8 \cdot V_{DD} / 0.2 \cdot V_{DD}$, S pins floating or $V_S = 0.8 \cdot V_{DD} / 0.2 \cdot V_{DD}$, D pins floating Refer to On Leakage Figure	-50	0.01	50	nA
LOGIC INPUTS						
V_{IH}	Input logic high		1.2		5.5	V
V_{IL}	Input logic low		0		0.45	V
I_{IH}	Input high leakage current	$V_{SEL} = 1.8V, V_{DD}$		1	± 2	μA
I_{IL}	Input low leakage current	$V_{SEL} = 0V$		0.2	± 2	μA
R_{PD}	Internal pull-down resistor on logic input pins			6		$M\Omega$
C_I	Logic input capacitance	$V_{SEL} = 0V, 1.8V$ or V_{DD} $f = 1MHz$		3		pF

5.6 Dynamic Characteristics

$V_{DD} = 1.5V$ to $5.5V$, $GND = 0V$, $T_A = -40^{\circ}C$ to $+125^{\circ}C$,
Typical values are at $V_{DD} = 3.3V$, $T_A = 25^{\circ}C$, (unless otherwise noted)

PARAMETER		TEST CONDITIONS	MIN	TYP	MAX	UNIT
C_{OFF}	Source and drain off capacitance	$V_S = V_{DD} / 2$ $V_{SEL} = 0V$ $f = 1MHz$ Refer to Capacitance Figure		2.5	4	pF
C_{ON}	Source and drain on capacitance	$V_S = V_{DD} / 2$ $V_{SEL} = V_{DD}$ $f = 1MHz$ Refer to Capacitance Figure		3.3	6	pF
Q_C	Charge Injection	$V_S = V_{DD} / 2$ $R_S = 0\Omega$, $C_L = 100pF$ Refer to Charge Injection Figure		2		pC
O_{ISO}	Off isolation	$R_L = 50\Omega$ $f = 100kHz$ Refer to Off Isolation Figure		-90		dB
		$R_L = 50\Omega$ $f = 1MHz$ Refer to Off Isolation Figure		-75		dB
X_{TALK}	Channel to Channel crosstalk	$R_L = 50\Omega$ $f = 100kHz$ Refer to Crosstalk Figure		-90		dB
BW	Bandwidth	$R_L = 50\Omega$ Refer to Bandwidth Figure		3		GHz
I_{LOSS}	Insertion loss	$R_L = 50\Omega$ $f = 1MHz$ Refer to Bandwidth Figure		-0.12		dB

5.7 Timing Requirements

$V_{DD} = 1.5V$ to $5.5V$, $GND = 0V$, $T_A = -40^{\circ}C$ to $+125^{\circ}C$,
Typical values are at $V_{DD} = 3.3V$, $T_A = 25^{\circ}C$, (unless otherwise noted)

PARAMETER		TEST CONDITIONS	MIN	TYP	MAX	UNIT
$t_{ON(VDD)}$	Device turn on time (V_{DD} to output)	$V_S = 3.6V$ V_{DD} rise time = $1\mu s$ $R_L = 200\Omega$, $C_L = 15pF$ Refer to Ton(vdd) & Toff(vdd) Figure		20	60	μs
$t_{OFF(VDD)}$	Device turn off time (V_{DD} to output)	$V_S = 3.6V$ V_{DD} fall time = $1\mu s$ $R_L = 200\Omega$, $C_L = 15pF$ Refer to Ton(vdd) & Toff(vdd) Figure		1.2	4	μs
t_{TRAN}	Transition time from control input	$V_{DD} = 2.5V$ to $5.5V$ $V_S = V_{DD}$ $R_L = 200\Omega$, $C_L = 15pF$ Refer to Transition Time Figure		25	55	ns
t_{TRAN}	Transition time from control input	$V_{DD} < 2.5V$ $V_S = V_{DD}$ $R_L = 200\Omega$, $C_L = 15pF$ Refer to Transition Time Figure		50	80	ns
$t_{SK(P)}$	Inter - channel skew	Refer to Tsk Figure		10		ps
t_{PD}	Propagation delay	Refer to Tpd Figure		67		ps

5.8 Typical Characteristics

at $T_A = 25^\circ\text{C}$, $V_{DD} = 5\text{V}$ (unless otherwise noted)

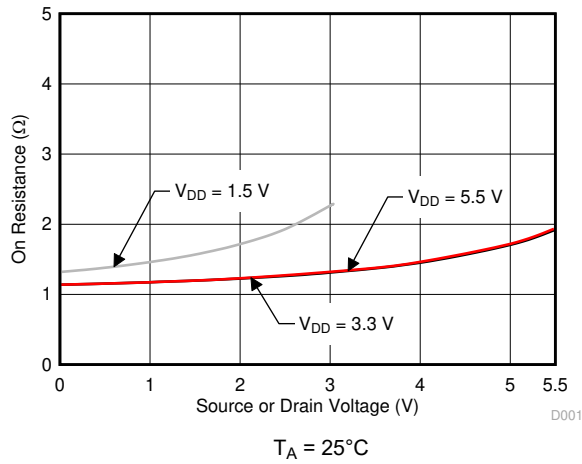

Figure 5-1. On-Resistance vs Source or Drain Voltage

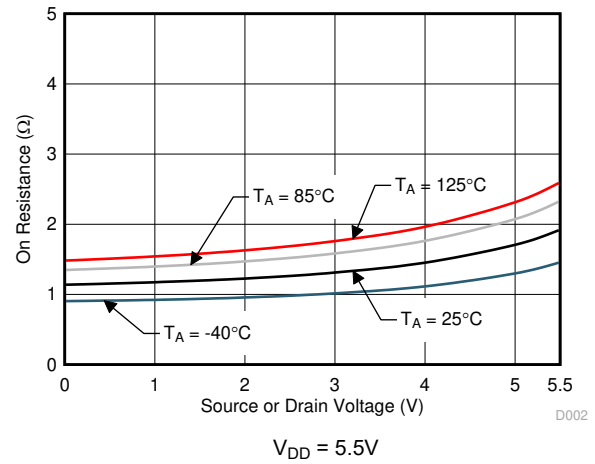

Figure 5-2. On-Resistance vs Source or Drain Voltage

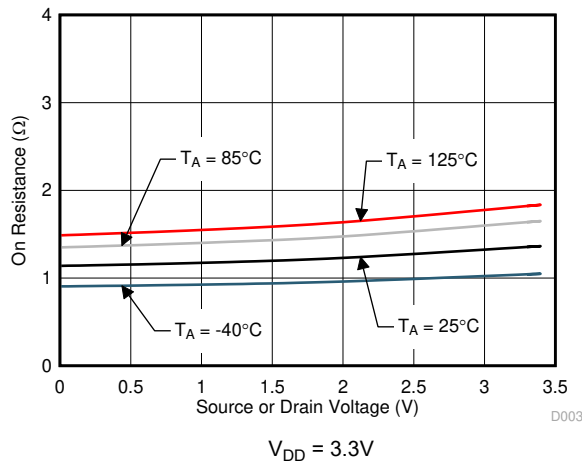

Figure 5-3. On-Resistance vs Source or Drain Voltage

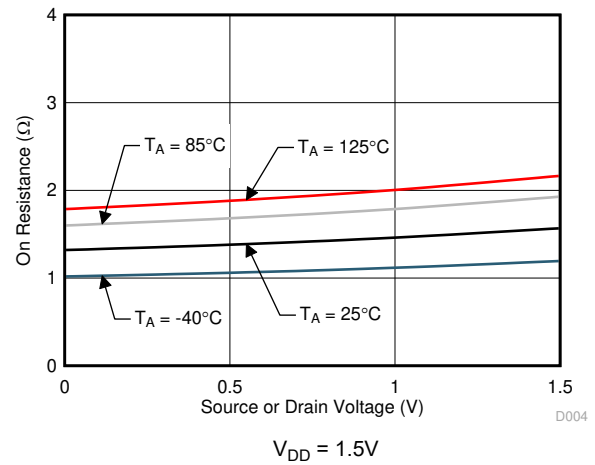

Figure 5-4. On-Resistance vs Source or Drain Voltage

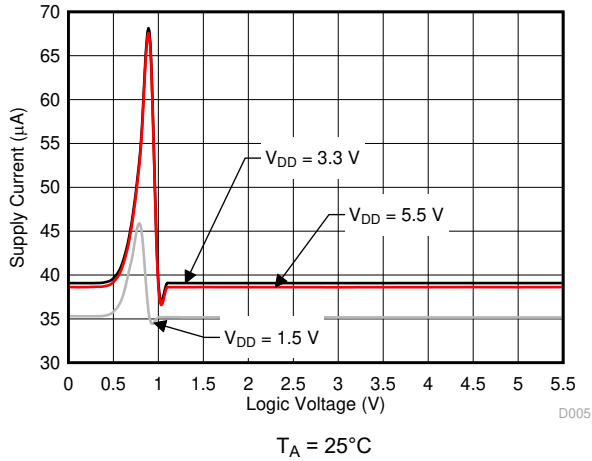

Figure 5-5. Supply Current vs Logic Voltage

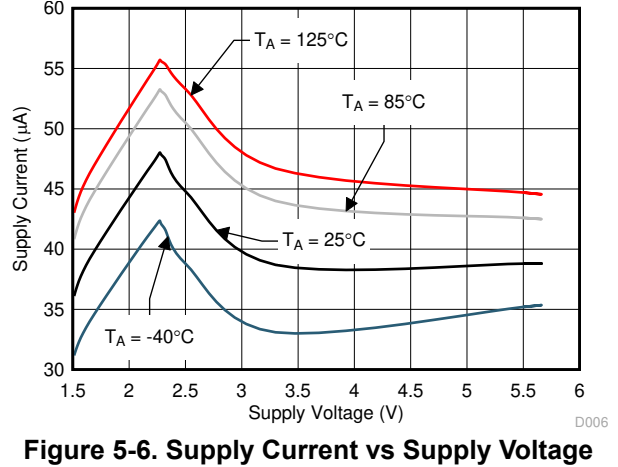

Figure 5-6. Supply Current vs Supply Voltage

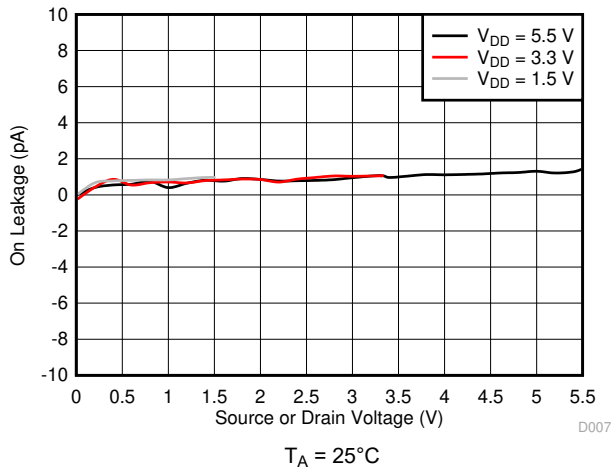

Figure 5-7. On-Leakage vs Source or Drain Voltage

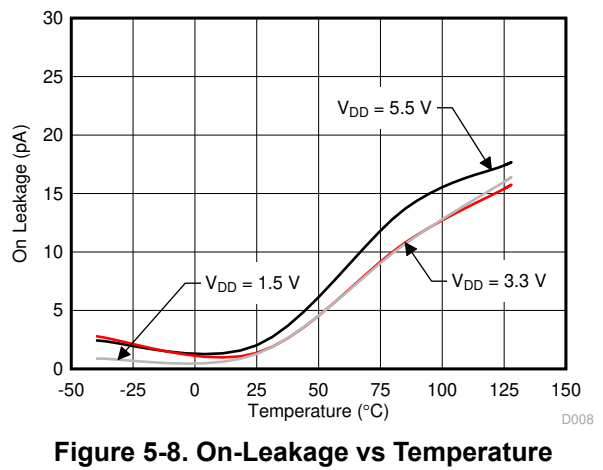

Figure 5-8. On-Leakage vs Temperature

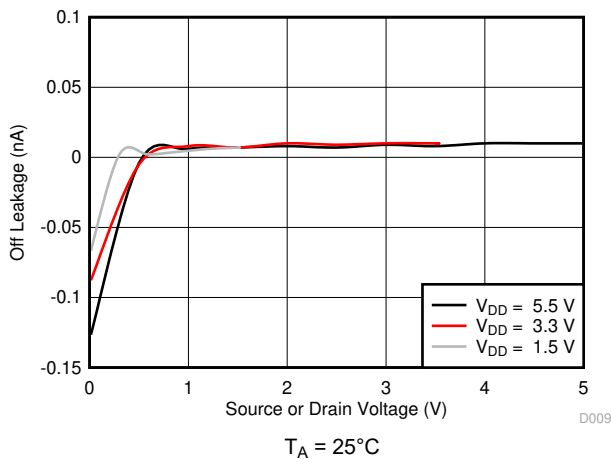

Figure 5-9. Off-Leakage vs Source or Drain Voltage

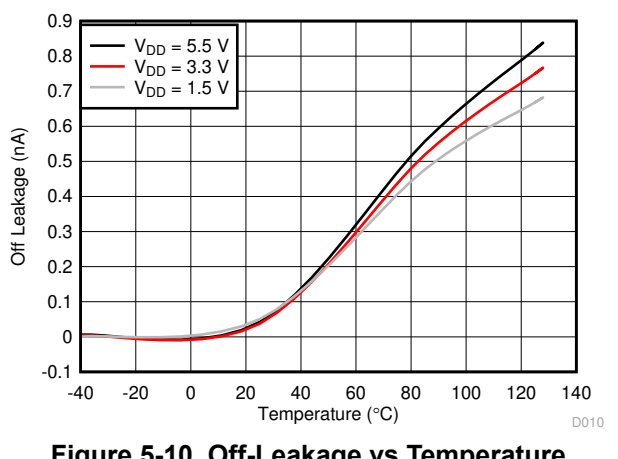

Figure 5-10. Off-Leakage vs Temperature

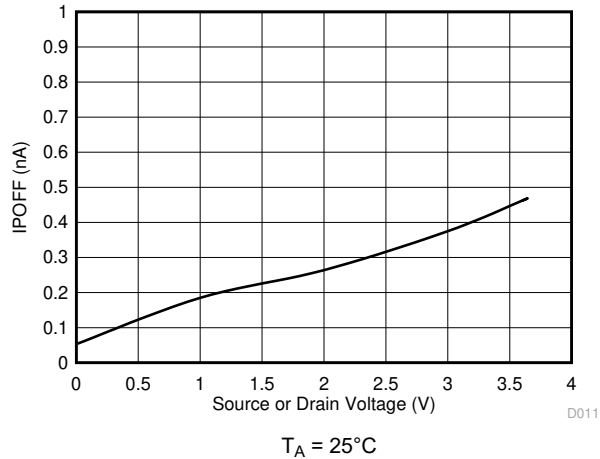

Figure 5-11. IPOFF Leakage vs Source or Drain Voltage

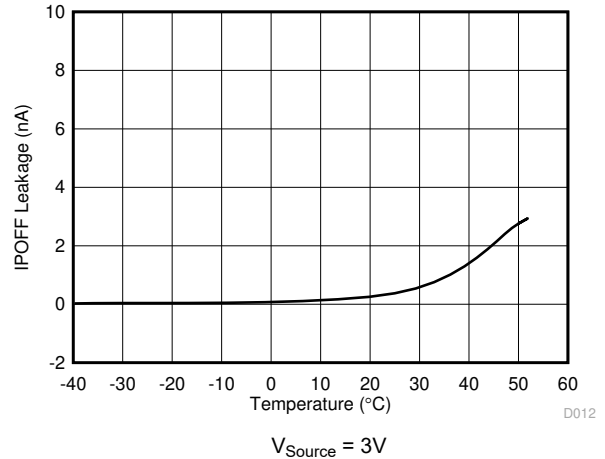

Figure 5-12. IPOFF Leakage vs Temperature

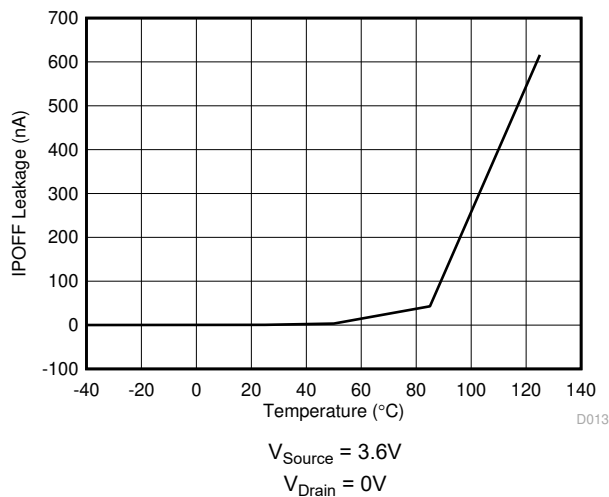

Figure 5-13. IPOFF Leakage vs Temperature

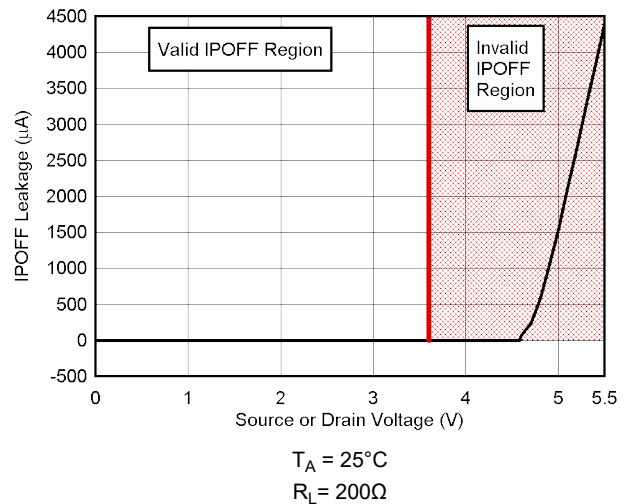

Figure 5-14. IPOFF Leakage vs Source or Drain Voltage

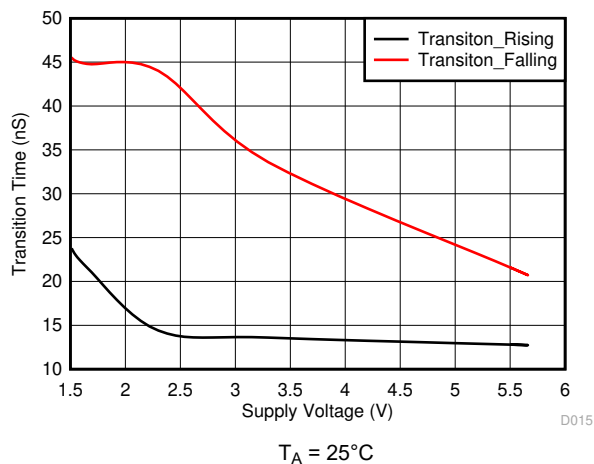

Figure 5-15. $T_{\text{TRANSITION}}$ vs Supply Voltage

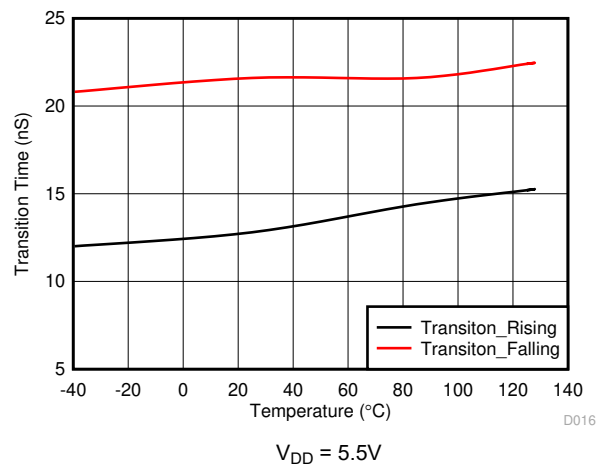

Figure 5-16. $T_{\text{TRANSITION}}$ vs Temperature

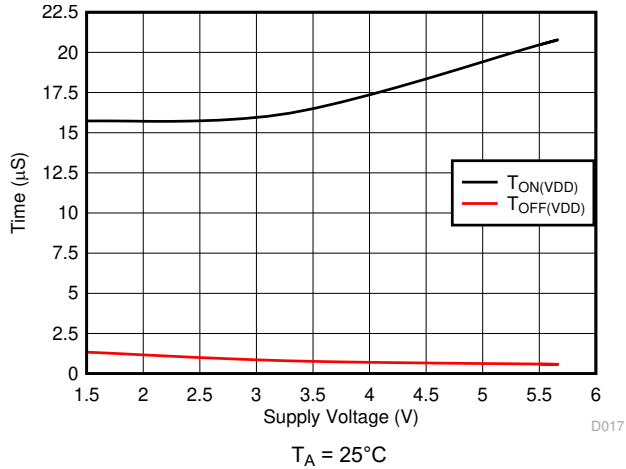

Figure 5-17. $T_{ON}(V_{DD})$ and $T_{OFF}(V_{DD})$ vs Supply Voltage

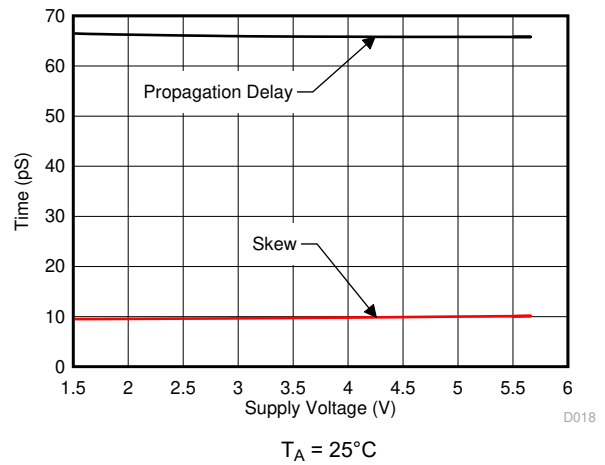

Figure 5-18. Skew and Propagation Delay vs Supply Voltage

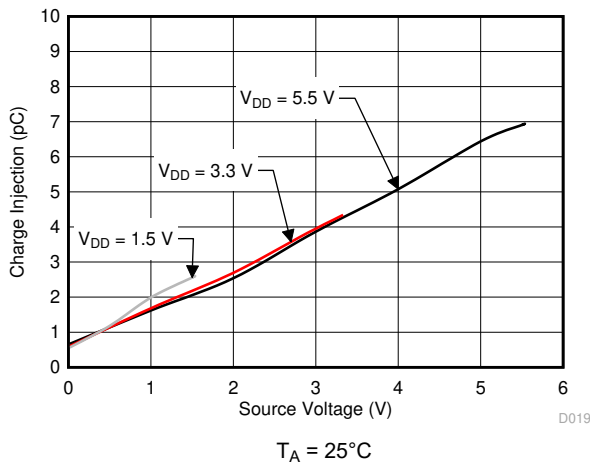

Figure 5-19. Charge Injection vs Source or Drain Voltage

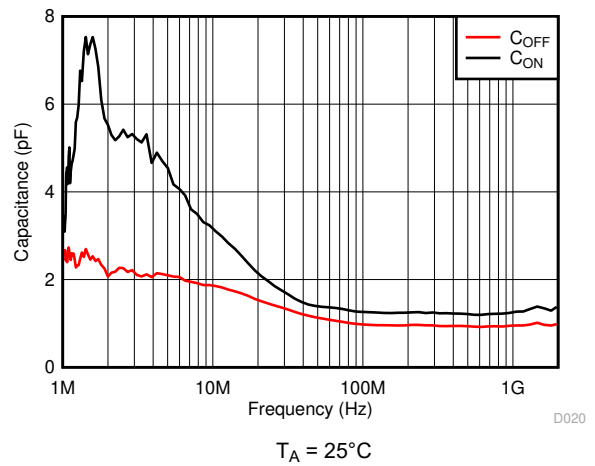

Figure 5-20. Capacitance vs Frequency

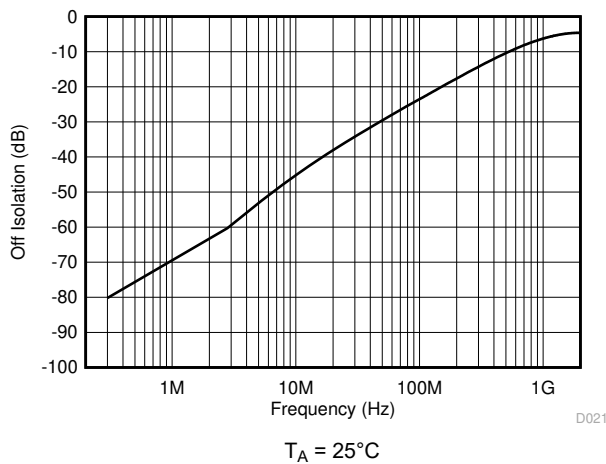

Figure 5-21. Off Isolation vs Frequency

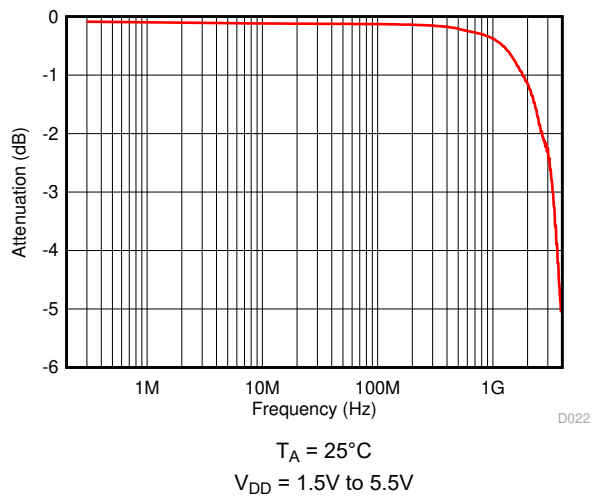
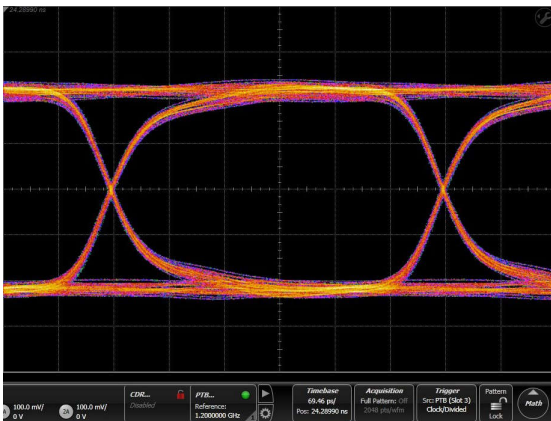

Figure 5-22. On-Response vs Frequency

5.8.1 Eye Diagrams



$T_A = 25^\circ\text{C}$
Bias = 1.5V
50Ω Termination

Figure 5-23. Eye Pattern: 2.4Gbps

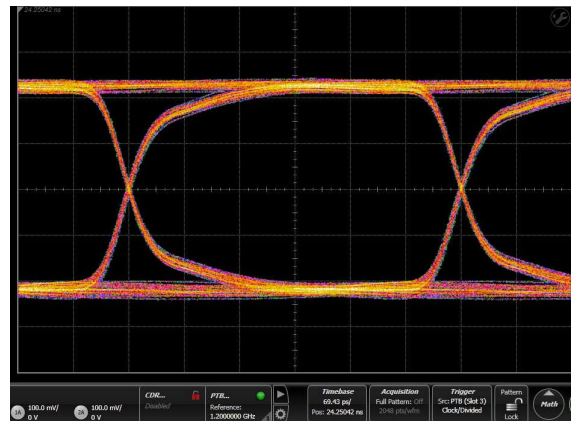

$T_A = 25^\circ\text{C}$
Bias = 1.5V
50Ω Termination

Figure 5-24. Eye Pattern: 2.4Gbps Through Path

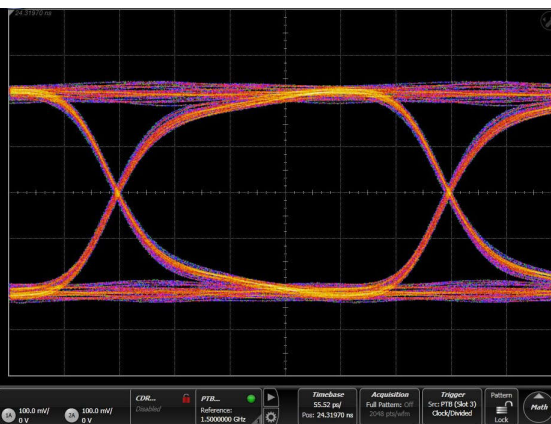

$T_A = 25^\circ\text{C}$
Bias = 1.5V
50Ω Termination

Figure 5-25. Eye Pattern: 3Gbps

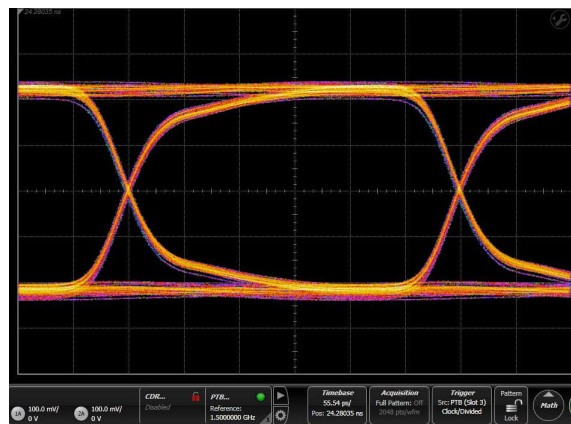

$T_A = 25^\circ\text{C}$
Bias = 1.5V
50Ω Termination

Figure 5-26. Eye Pattern: 3Gbps Through Path

6 Parameter Measurement Information

6.1 On-Resistance

The on-resistance of a device is the ohmic resistance between the source (Sx) and drain (Dx) pins of the device. The on-resistance varies with input voltage and supply voltage. The symbol R_{ON} is used to denote on-resistance. The measurement setup used to measure R_{ON} is shown in [Figure 6-1](#). Voltage (V) and current (I_{DS}) are measured using this setup, and R_{ON} is computed as shown below with $R_{ON} = V / I_{SD}$:

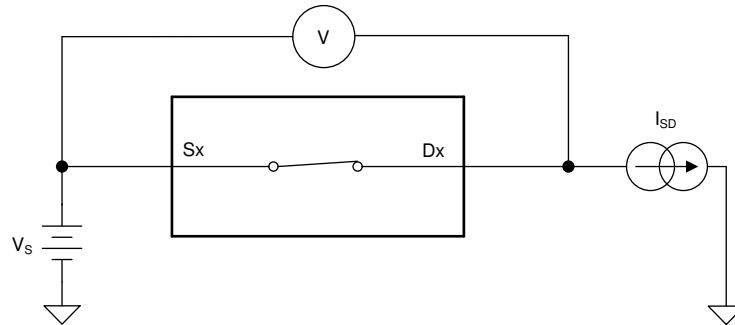

Figure 6-1. On-Resistance Measurement Setup

6.2 Off-Leakage Current

Source off-leakage current is defined as the leakage current flowing into or out of the source pin when the switch is off. This current is denoted by the symbol $I_{S(OFF)}$.

Drain off-leakage current is defined as the leakage current flowing into or out of the drain pin when the switch is off. This current is denoted by the symbol $I_{D(OFF)}$.

The setup used to measure both off-leakage currents is shown in [Figure 6-2](#).

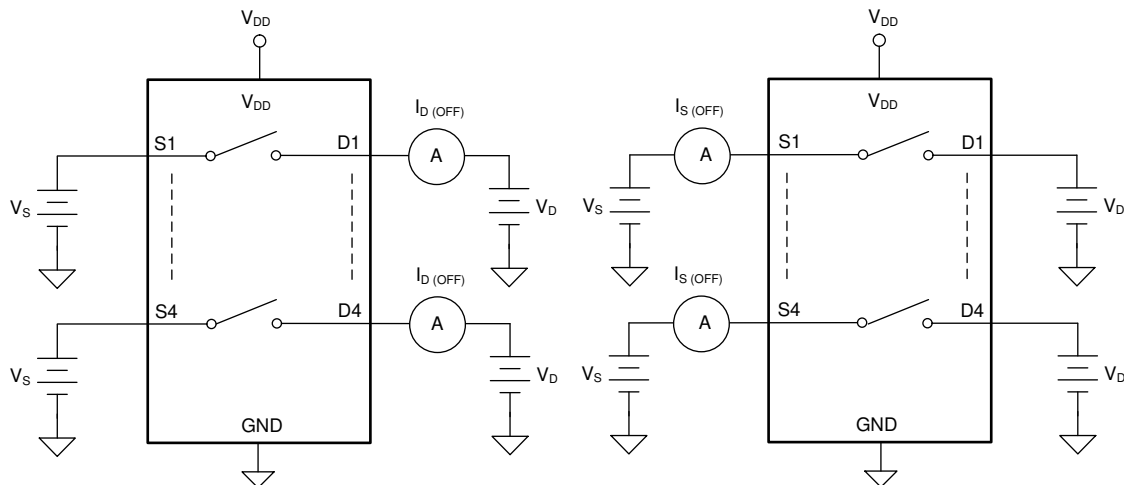

Figure 6-2. Off-Leakage Measurement Setup

6.3 On-Leakage Current

Source on-leakage current is defined as the leakage current flowing into or out of the source pin when the switch is on. This current is denoted by the symbol $I_{S(ON)}$.

Drain on-leakage current is defined as the leakage current flowing into or out of the drain pin when the switch is on. This current is denoted by the symbol $I_{D(ON)}$.

Either the source pin or drain pin is left floating during the measurement. [Figure 6-3](#) shows the circuit used for measuring the on-leakage current, denoted by $I_{S(ON)}$ or $I_{D(ON)}$.

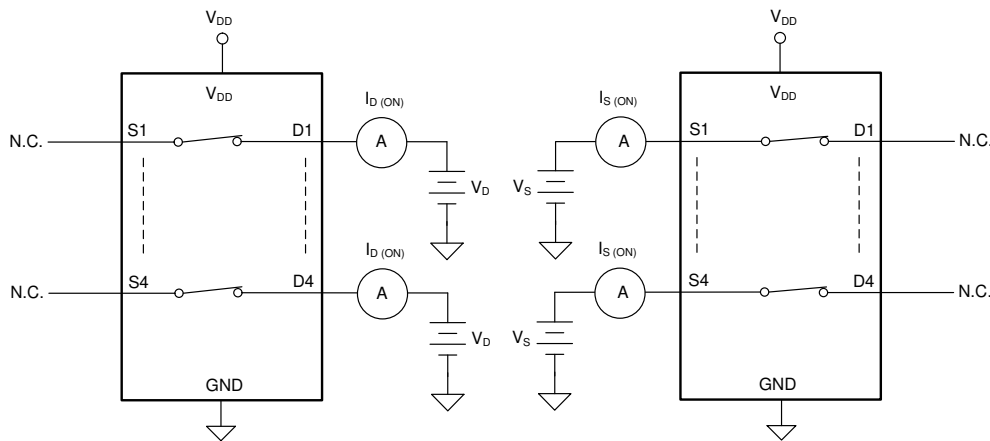

Figure 6-3. On-Leakage Measurement Setup

6.4 IPOFF Leakage Current

IPOFF leakage current is defined as the leakage current flowing into or out of the source pin when the device is powered off. This current is denoted by the symbol I_{POFF} .

The setup used to measure both IPOFF leakage current is shown in [Figure 6-4](#).

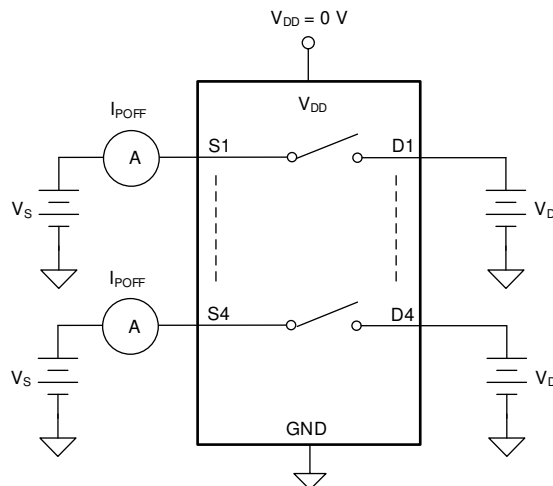

Figure 6-4. IPOFF Leakage Measurement Setup

6.5 Transition Time

Transition time is defined as the time taken by the output of the device to rise or fall 10% after the control select signal has risen or fallen past the logic threshold. The 10% transition measurement is utilized to provide the timing of the device. The time constant from the load resistance and load capacitance can be added to the transition time to calculate system level timing. Figure 6-5 shows the setup used to measure transition time, denoted by the symbol $t_{\text{TRANSITION}}$.

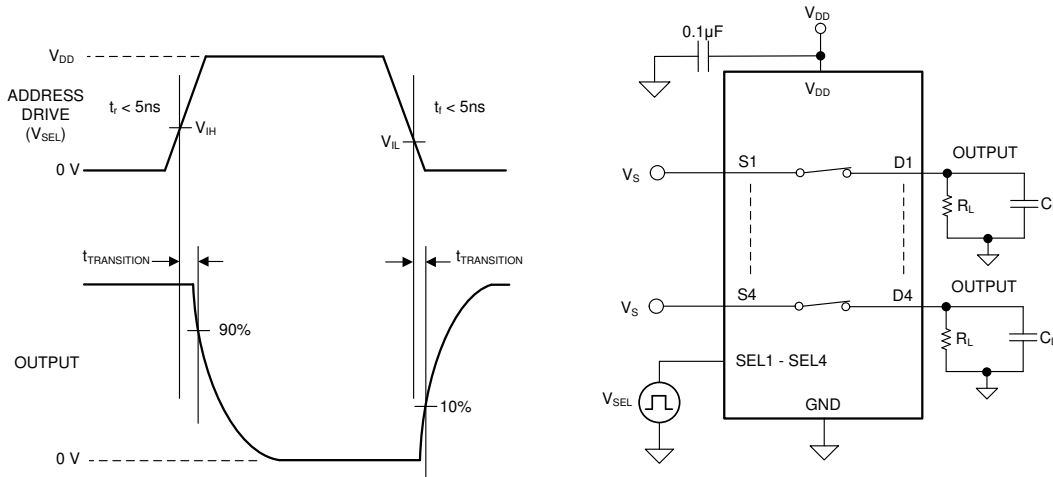

Figure 6-5. Transition-Time Measurement Setup

6.6 $T_{\text{ON}}(V_{\text{DD}})$ and $T_{\text{OFF}}(V_{\text{DD}})$ Time

$T_{\text{ON}}(V_{\text{DD}})$ time is defined as the time taken by the output of the device to rise to 90% after the supply has risen past the supply threshold. The 90% measurement is utilized to provide the timing of the device turning on in the system. The time constant from the load resistance and load capacitance can be added to the turn-on-VDD time to calculate system level timing. Figure 6-6 shows the setup used to measure transition time, denoted by the symbol $t_{\text{ON}}(V_{\text{DD}})$.

$T_{\text{OFF}}(V_{\text{DD}})$ time is defined as the time taken by the output of the device to fall to 90% after the enable has fallen past the supply threshold. The 90% measurement is utilized to provide the timing of the device turning off in the system. The time constant from the load resistance and load capacitance can be added to the turn-off-VDD time to calculate system level timing. Figure 6-6 shows the setup used to measure transition time, denoted by the symbol $t_{\text{OFF}}(V_{\text{DD}})$.

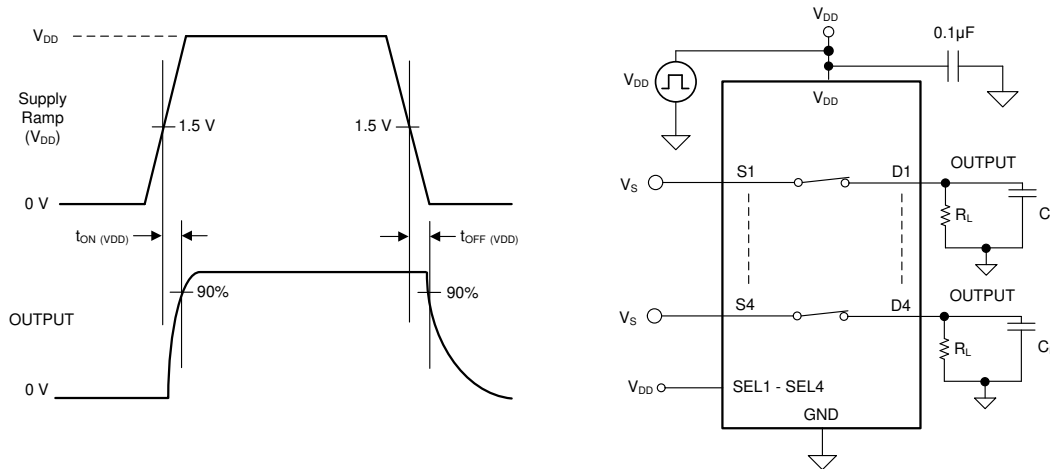

Figure 6-6. Turn-On-VDD and Turn-Off-VDD Time Measurement Setup

6.7 Propagation Delay

Propagation delay is defined as the time taken by the output of the device to rise or fall 50% after the input signal has risen or fallen past the 50% threshold. Figure 6-7 shows the setup used to measure propagation delay, denoted by the symbol t_{PD} .

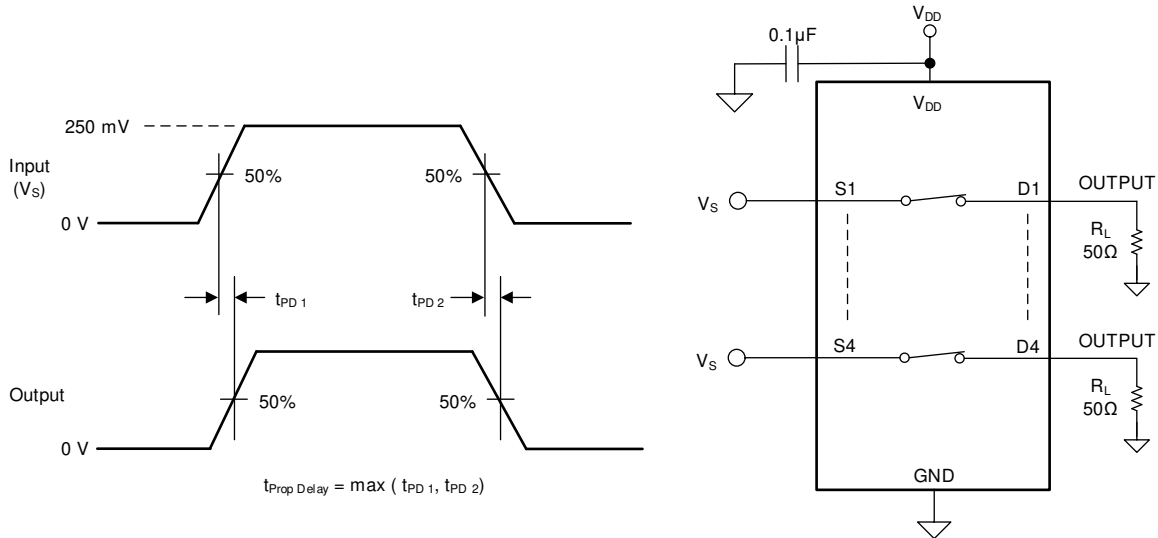

Figure 6-7. Propagation Delay Measurement Setup

6.8 Skew

Skew is defined as the difference between propagation delays of any two outputs of the same device. The skew measurement is taken from the output of one channel rising or falling past 50% to a second channel rising or falling past the 50% threshold when the input signals are switched at the same time. Figure 6-8 shows the setup used to measure skew, denoted by the symbol t_{SK} .

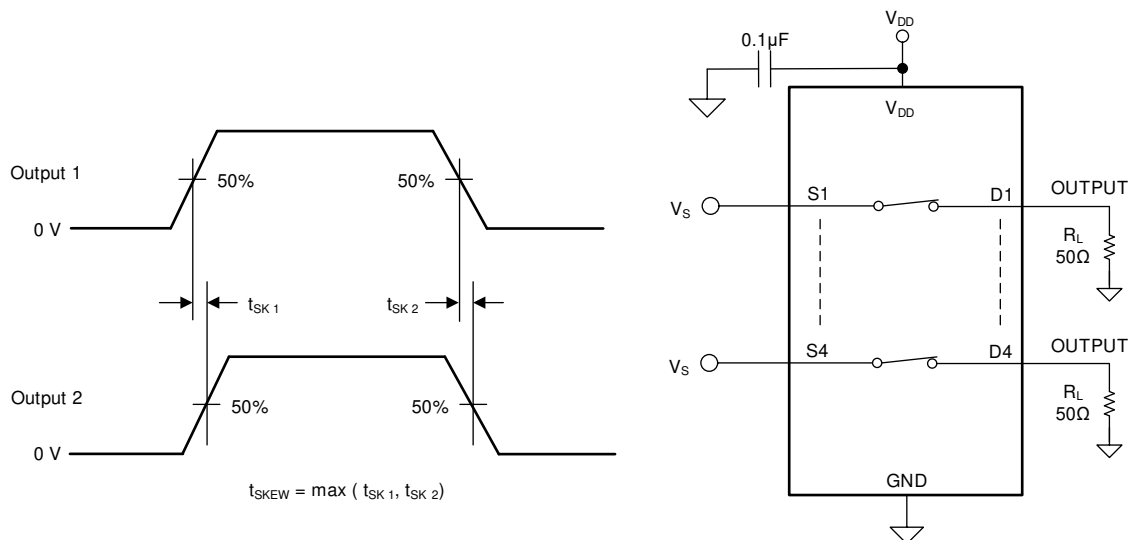

Figure 6-8. Skew Measurement Setup

6.9 Charge Injection

The amount of charge injected into the source or drain of the device during the falling or rising edge of the gate signal is known as charge injection, and is denoted by the symbol Q_C . Figure 6-9 shows the setup used to measure charge injection from source (Sx) to drain (Dx).

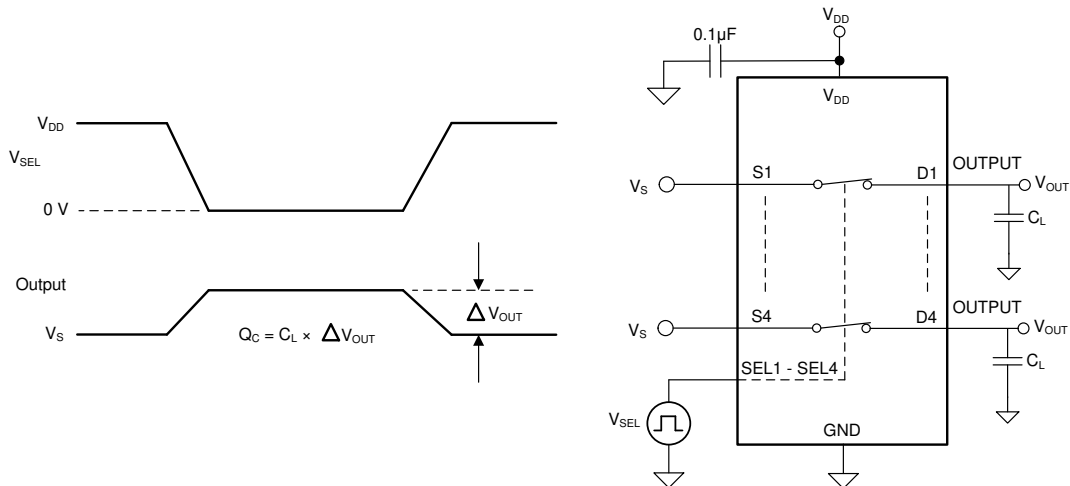

Figure 6-9. Charge-Injection Measurement Setup

6.10 Capacitance

The parasitic capacitance of the device is captured at the source (Sx), drain (Dx), and select (SELx) pins. The capacitance is measured in both the on and off state and is denoted by the symbol C_{ON} and C_{OFF} . Figure 6-10 shows the setup used to measure capacitance.

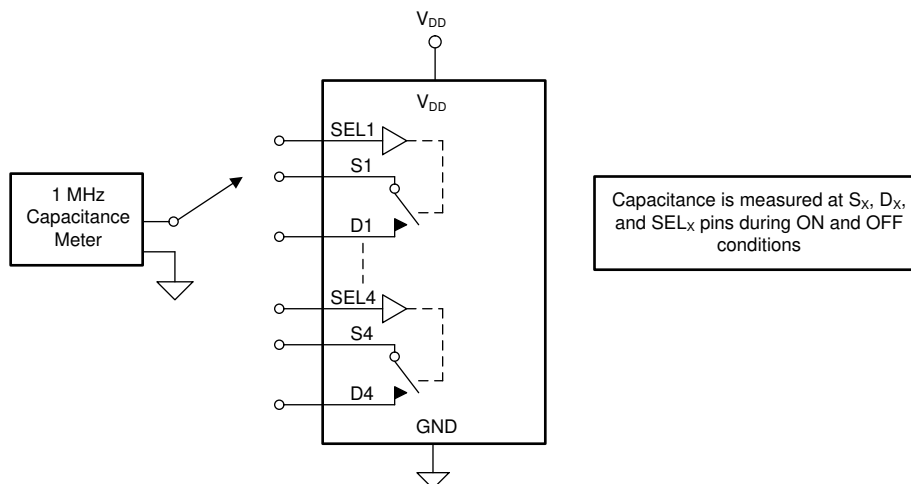

Figure 6-10. Capacitance Measurement Setup

6.11 Off Isolation

Off isolation is defined as the ratio of the signal at the drain pin (Dx) of the device when a signal is applied to the source pin (Sx) of an off-channel. The characteristic impedance, Z_0 , for the measurement is 50Ω . Figure 6-11 shows the setup used to measure off isolation. Use off isolation equation to compute off isolation.

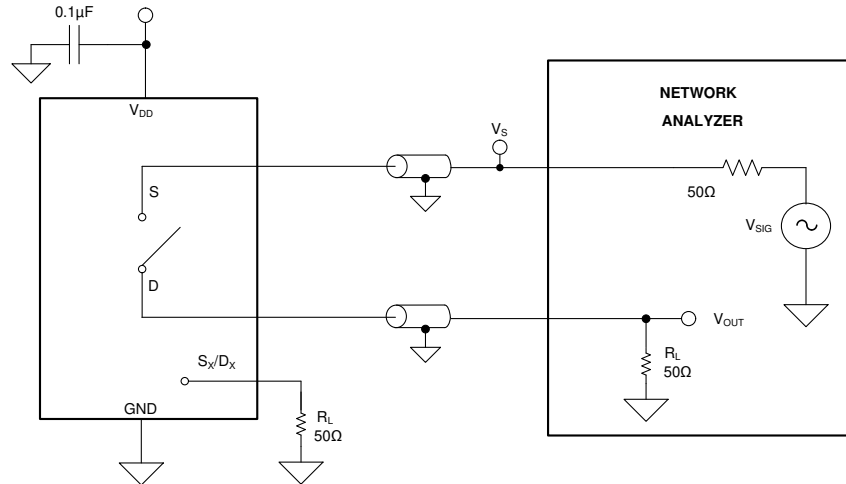

Figure 6-11. Off Isolation Measurement Setup

$$\text{Off Isolation} = 20 \cdot \text{Log} \left(\frac{V_{\text{OUT}}}{V_{\text{S}}} \right) \tag{1}$$

6.12 Channel-to-Channel Crosstalk

Crosstalk is defined as the ratio of the signal at the drain pin (Dx) of a different channel, when a signal is applied at the source pin (Sx) of an on-channel. The characteristic impedance, Z_0 , for the measurement is 50Ω . Figure 6-12 shows the setup used to measure, and the equation used to compute crosstalk.

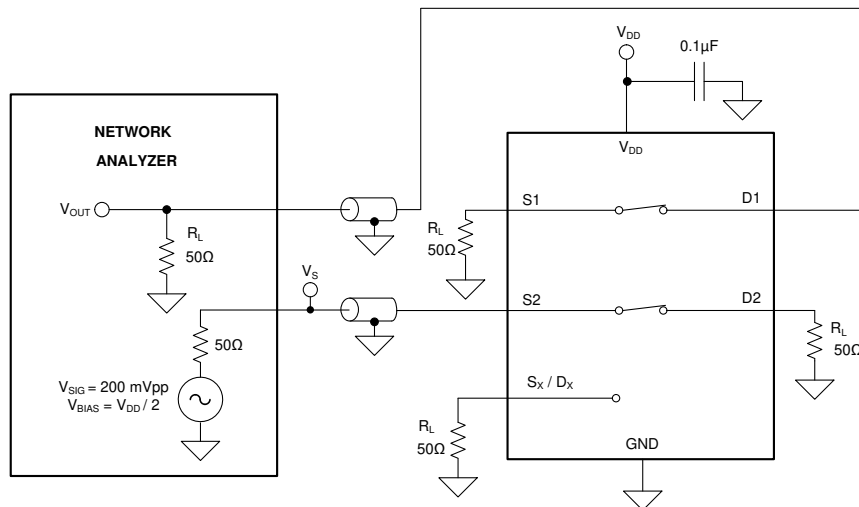

Figure 6-12. Channel-to-Channel Crosstalk Measurement Setup

$$\text{Channel-to-Channel Crosstalk} = 20 \cdot \text{Log} \left(\frac{V_{\text{OUT}}}{V_{\text{S}}} \right) \tag{2}$$

6.13 Bandwidth

Bandwidth is defined as the range of frequencies that are attenuated by less than 3dB when the input is applied to the source pin (Sx) of an on-channel, and the output is measured at the drain pin (Dx) of the device. The characteristic impedance, Z_0 , for the measurement is 50Ω. Figure 6-13 shows the setup used to measure bandwidth.

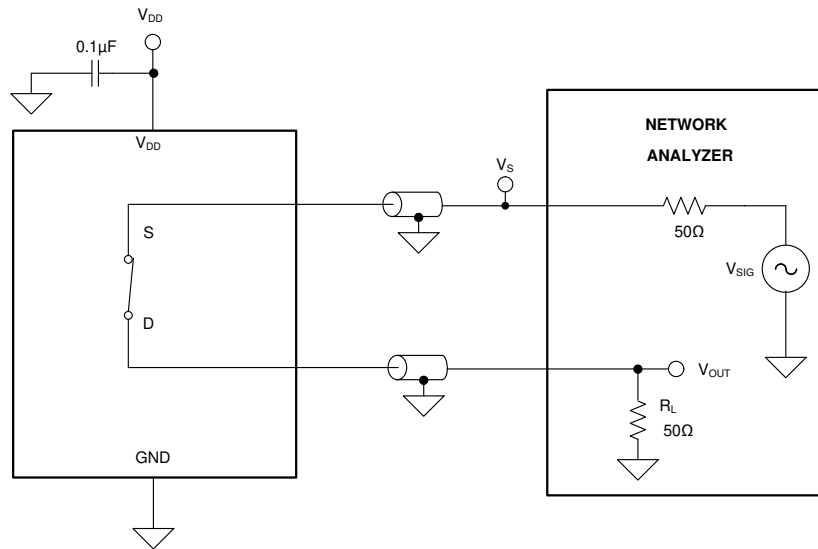

Figure 6-13. Bandwidth Measurement Setup

7 Detailed Description

7.1 Overview

The TMUX1511 is a high speed 1:1 (SPST) 4-channel switch with powered-off protection up to 3.6V. Wide operating supply of 1.5V to 5.5V allows for use in a broad array of applications from servers and communication equipment to industrial applications. The device supports bidirectional analog and digital signals on the source (Sx) and drain (Dx) pins. The wide bandwidth of this switch allows little or no attenuation of the high-speed signals at the outputs to pass with minimum edge and phase distortion as well as propagation delay.

The select (SELx) pins are active-high logic pins that control the connection between the source (Sx) and drain (Dx) pins of the device. Each channel of the TMUX1511 can be controlled independently through the associated select pin, or all four select pins can be tied together for simultaneous control of all channels with a single GPIO. Fail-Safe Logic circuitry allows voltages on the logic control pins to be applied before the supply pin, protecting the device from potential damage. All logic control inputs have 1.8V logic compatible thresholds, ensuring both TTL and CMOS logic compatibility when operating in the valid supply voltage range.

Powered-off protection up to 3.6V on the signal path of the TMUX1511 provides isolation when the supply voltage is removed ($V_{DD} = 0V$). Without this protection feature, the system can back-power the supply rail through an internal ESD diode and cause potential damage to the system.

7.2 Functional Block Diagram

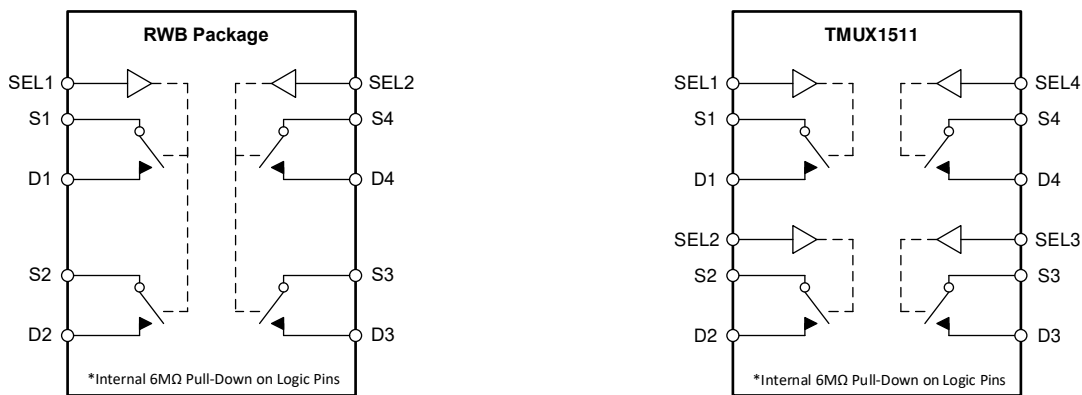

7.3 Feature Description

7.3.1 Bidirectional Operation

The TMUX1511 conducts equally well from source (Sx) to drain (Dx) or from drain (Dx) to source (Sx). Each channel has very similar characteristics in both directions and supports both analog and digital signals.

7.3.2 Beyond Supply Operation

When the TMUX1511 is powered from 1.5V to 5.5V, the valid signal path input/output voltage ranges from GND to $V_{DD} \times 2$, with a maximum input/output voltage of 5.5V.

Example 1: If the TMUX1511 is powered at 1.5V, the signal range is 0V to 3V.

Example 2: If the TMUX1511 is powered at 3V, the signal range is 0V to 5.5V.

Example 3: If the TMUX1511 is powered at 5.5V, the signal range is 0V to 5.5V.

Other voltage levels not mentioned in the examples will support Beyond Supply Operation as long as the supply voltage falls within the recommended operation conditions of 1.5V to 5.5V.

7.3.3 1.8V Logic Compatible Inputs

The TMUX1511 has 1.8V logic compatible control inputs. Regardless of the V_{DD} voltage, the control input thresholds remain fixed, allowing a 1.8V processor GPIO to control the TMUX1511 without the need for an

external translator. This saves both space and BOM cost. For more information on 1.8V logic implementations refer to [Simplifying Design with 1.8 V Logic Muxes and Switches](#).

7.3.4 Powered-off Protection

Powered-off protection up to 3.6V on the signal path of the TMUX1511 provides isolation when the supply voltage is removed ($V_{DD} = 0V$). When the TMUX1511 is powered-off, the I/Os of the device remain in a high-Z state. Powered-off protection minimizes system complexity by removing the need for power supply sequencing on the signal path. The device performance remains within the leakage performance mentioned in the Electrical Specifications. For more information on powered-off protection refer to [Eliminate Power Sequencing with Powered-off Protection Signal Switches](#)

7.3.5 Fail-Safe Logic

The TMUX1511 has Fail-Safe Logic on the control input pins (SELx) which allows for operation up to 5.5V, regardless of the state of the supply pin. This feature allows voltages on the control pins to be applied before the supply pin, protecting the device from potential damage. Fail-Safe Logic minimizes system complexity by removing the need for power supply sequencing on the logic control pins. For example, the Fail-Safe Logic feature allows the select pins of the TMUX1511 to be ramped to 5.5V while $V_{DD} = 0V$. Additionally, the feature enables operation of the TMUX1511 with $V_{DD} = 1.5V$ while allowing the select pins to interface with a logic level of another device up to 5.5V.

7.3.6 Low Capacitance

The TMUX1511 has very low capacitance in both the ON and OFF states on the source and drain pins. The low capacitance specification allows the TMUX1511 to be used in applications such as sample & hold circuits, and in the feedback path of an operation amplifier. Low capacitance helps to reduce large overshoots and ringing of an amplifier circuit when the switch is connected to the feedback network. Additionally, low capacitance improves system settling time by reducing the switch time constant formed by the On-resistance and On-capacitance. For more information on the benefits of low capacitance refer to [Improve Stability Issues with Low \$C_{ON}\$ Multiplexers](#).

7.3.7 Integrated Pull-Down Resistors

The TMUX1511 has internal weak pull-down resistors ($6M\Omega$) to GND to ensure the logic pins are not left floating. This feature integrates up to four external components and reduces system size and cost.

7.4 Device Functional Modes

The select (SELx) pins are active-high logic pins that control the connection between the source (Sx) and drain (Dx) pins of the device. The TMUX1511 has internal weak pull-down resistors ($6M\Omega$) to GND so that it powers-on with the switches disabled. When a given select pin of the TMUX1511 is pulled high, the corresponding switch conducts from the source to drain. When any of the select pins are pulled low, the corresponding switch is in an open state (HI-Z). Each channel of the TMUX1511 can be controlled independently through the associated select pin, or all four select pins can be tied together for simultaneous control of all channels with a single GPIO.

7.5 Truth Tables

[Table 7-1](#) shows the truth table for the TMUX1511.

Table 7-1. TMUX1511 Truth Table

SELx	Sx / Dx: STATE
0	Hi-Z (OFF)
1	Conducting (ON)

8 Application and Implementation

Note

Information in the following applications sections is not part of the TI component specification, and TI does not warrant its accuracy or completeness. TI's customers are responsible for determining suitability of components for their purposes. Customers should validate and test their design implementation to confirm system functionality.

8.1 Application Information

The TMUX15xx family offers high-speed system performance across a wide operating supply (1.5V to 5.5V) and operating temperature (-40°C to +125°C). The TMUX1511 supports a number of features that improve system performance such as [Section 7.3.3](#), [input voltages beyond supply](#), [Fail-Safe Logic](#). These features make the TMUX15xx a family of protection multiplexers and switches that can reduce system complexity, board size, and overall system cost.

8.2 Typical Application

8.2.1 Protocol / Signal Isolation

One useful application to take advantage of the TMUX1511 features is isolating various protocols from a processor or MCU such as JTAG, SPI, or standard GPIO signals. The device provides excellent isolation performance when the device is powered. The added benefit of powered-off protection allows a system to minimize complexity by eliminating the need for power sequencing in hot-swap and live insertion applications.

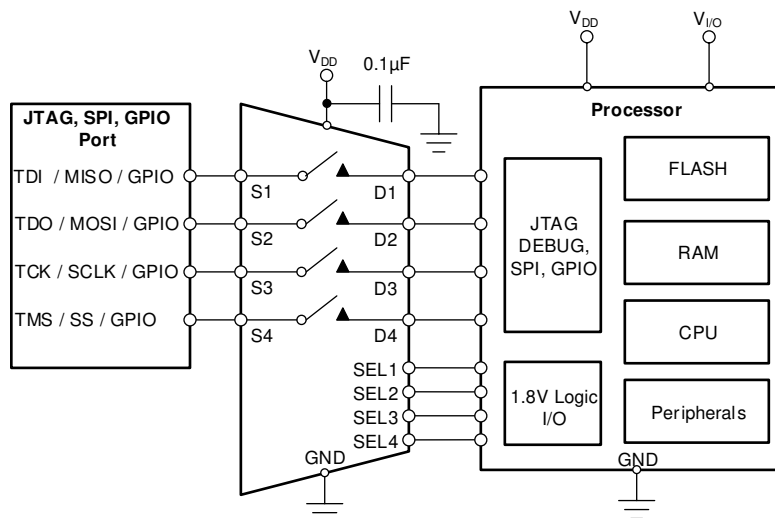

Figure 8-1. Isolation of JTAG, SPI, and GPIO Signals

8.2.1.1 Design Requirements

For this design example, use the parameters listed in Table 2.

Table 8-1. Design Parameters

PARAMETERS	VALUES
Supply (V_{DD})	3.3V
Input / Output signal range	0V to 3.3V
Control logic thresholds	1.8V compatible

8.2.1.2 Detailed Design Procedure

The TMUX1511 can be operated without any external components except for the supply decoupling capacitors. The device has internal weak pull-down resistors ($6M\Omega$) to GND so that it powers-on with the switches disabled. All inputs signals passing through the switch must fall within the recommend operating conditions of the TMUX1511 including signal range and continuous current. For this design example, with a supply of 3.3V, the signals can range from 0V to 3.3V when the device is powered. This example can also utilize the feature and the inputs can range from 0V to 3.3V when $V_{DD} = 0V$. The max continuous current can be 25mA. Due to the voltage range and high speed capability, the TMUX1511 example is suitable for use in JTAG and SPI applications beyond the 100MHz maximum in a typical application.

8.2.1.3 Application Curves

Two important specifications when using a switch or multiplexer to pass signals are the device propagation delay and skew.

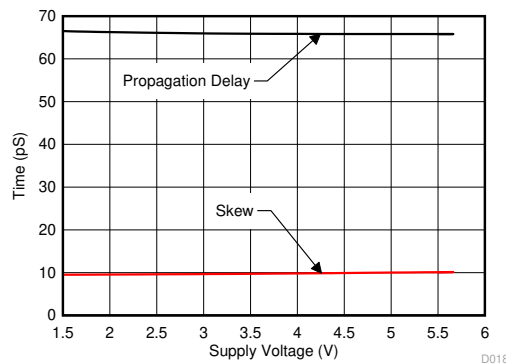

Figure 8-2. Propagation Delay and Skew Measurement

8.2.2 Transimpedance Amplifier Feedback Control

Switches and multiplexers are commonly used in the feedback path of amplifier circuits to provide configurable gain control. By using various resistor values on each switch path the TMUX1511 allows the system to have multiple gain settings. An external resistor, or utilizing 1 channel always being closed, ensures the amplifier isn't operating in an open loop configuration. A transimpedance amplifier (TIA) for photodiodes is a common circuit that requires gain control using a multi-channel switch to convert the output current of the photodiode into a voltage for the MCU or processor. The leakage current, capacitance, and charge injection performance of the TMUX1511 are key specifications to evaluate when selecting a device for gain control.

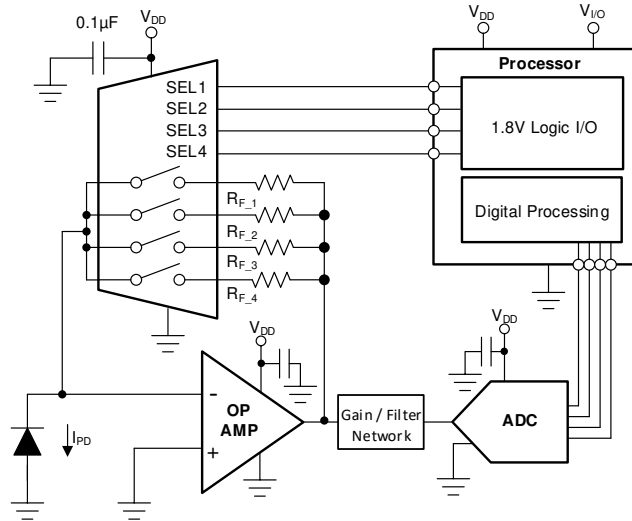

Figure 8-3. Multiplexing Gain for a TIA Circuit

8.2.2.1 Design Requirements

For this design example, use the parameters listed in Table 3.

Table 8-2. Design Parameters

PARAMETERS	VALUES
Supply (V_{DD})	5V
Input / Output signal range	0 μ A to 10 μ A
Control logic thresholds	1.8V compatible

8.2.2.2 Detailed Design Procedure

Photodiodes commonly have a current output that ranges from a few hundred picoamps to tens of microamps based on the amount of light being absorbed. The TMUX1511 has a typical On-leakage current of less than 10pA which would lead to an accuracy well within 1% of a full scale 10 μ A signal. The low ON and OFF capacitance of the TMUX1511 improves system stability by minimizing the total capacitance on the output of the amplifier. Lower capacitance leads to less overshoot and ringing in the system which can cause the amplifier circuit to go unstable if the phase margin is not at least 45°. Refer to [Improve Stability Issues with Low \$C_{ON}\$ Multiplexers](#) for more information on calculating the phase margin vs. percent overshoot.

8.2.2.3 Application Curves

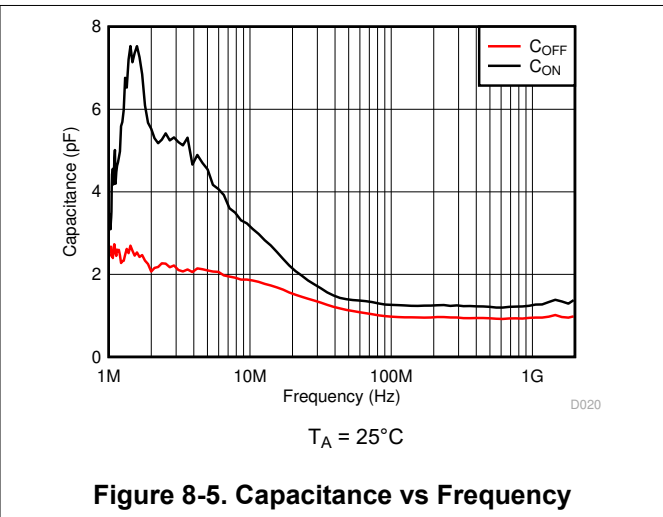
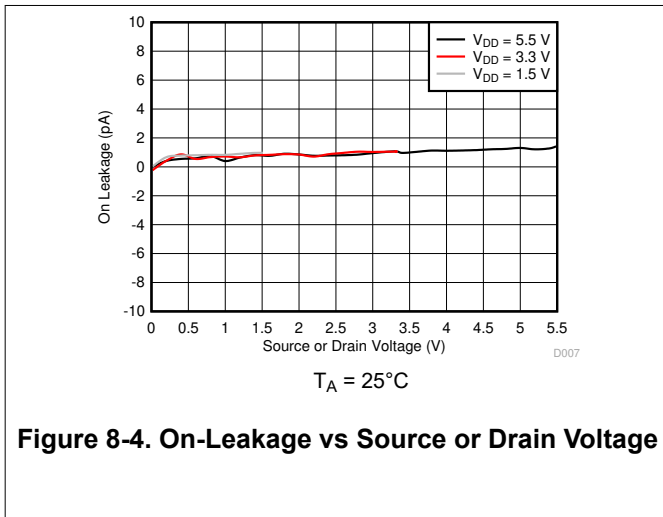

9 Power Supply Recommendations

The TMUX1511 operates across a wide supply range of 1.5V to 5.5V. Do not exceed the absolute maximum ratings because stresses beyond the listed ratings can cause permanent damage to the devices.

Power-supply bypassing improves noise margin and prevents switching noise propagation from the V_{DD} supply to other components. Good power-supply decoupling is important to achieve optimum performance. For improved supply noise immunity, use a supply decoupling capacitor ranging from 0.1 μ F to 10 μ F from V_{DD} to ground. Place the bypass capacitors as close to the power supply pins of the device as possible using low-impedance connections. TI recommends using multi-layer ceramic chip capacitors (MLCCs) that offer low equivalent series resistance (ESR) and inductance (ESL) characteristics for power-supply decoupling purposes. For very sensitive systems, or for systems in harsh noise environments, avoiding the use of vias for connecting the capacitors to the device pins may offer superior noise immunity. The use of multiple vias in parallel lowers the overall inductance and is beneficial for connections to ground planes.

10 Layout

10.1 Layout Guidelines

When a PCB trace turns a corner at a 90° angle, a reflection can occur. A reflection occurs primarily because of the change of width of the trace. At the apex of the turn, the trace width increases to 1.414 times the width. This increase upsets the transmission-line characteristics, especially the distributed capacitance and self-inductance of the trace which results in the reflection. Not all PCB traces can be straight and therefore some traces must turn corners. [Figure 10-1](#) shows progressively better techniques of rounding corners. Only the last example (BEST) maintains constant trace width and minimizes reflections.

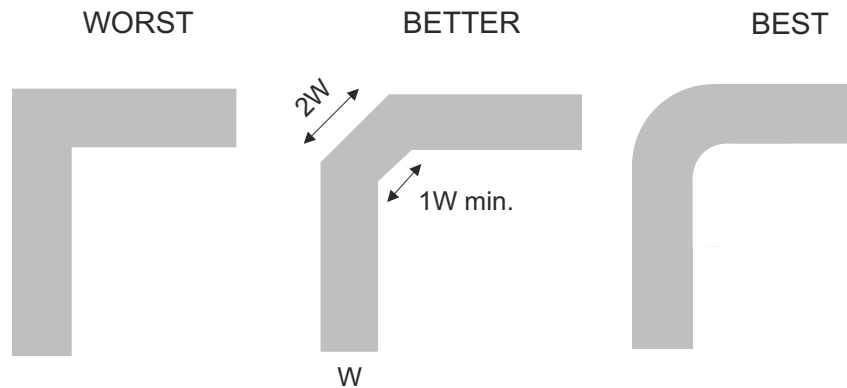

Figure 10-1. Trace Example

Route the high-speed signals using a minimum of vias and corners which reduces signal reflections and impedance changes. When a via must be used, increase the clearance size around it to minimize its capacitance. Each via introduces discontinuities in the signal's transmission line and increases the chance of picking up interference from the other layers of the board. Be careful when designing test points, through-hole pins are not recommended at high frequencies.

Do not route high speed signal traces under or near crystals, oscillators, clock signal generators, switching regulators, mounting holes, magnetic devices or ICs that use or duplicate clock signals.

Avoid stubs on the high-speed signals traces because they cause signal reflections.

Route all high-speed signal traces over continuous GND planes, with no interruptions.

Avoid crossing over anti-etch, commonly found with plane splits.

When working with high frequencies, a printed circuit board with at least four layers is recommended; two signal layers separated by a ground and power layer as shown in [Figure 10-2](#).

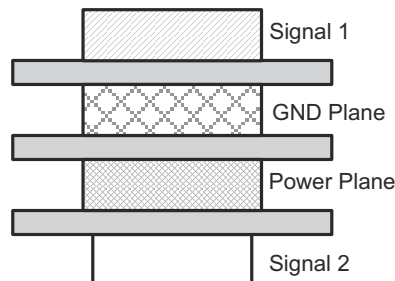

Figure 10-2. Example Layout

The majority of signal traces must run on a single layer, preferably Signal 1. Immediately next to this layer must be the GND plane, which is solid with no cuts. Avoid running signal traces across a split in the ground or power plane. When running across split planes is unavoidable, sufficient decoupling must be used. Minimizing the number of signal vias reduces EMI by reducing inductance at high frequencies.

Figure 10-3 illustrates an example of a PCB layout with the TMUX1511. Some key considerations are:

Decouple the V_{DD} pin with a $0.1\mu\text{F}$ capacitor, placed as close to the pin as possible. Make sure that the capacitor voltage rating is sufficient for the V_{DD} supply.

High-speed switches require proper layout and design procedures for optimum performance.

Keep the input lines as short as possible.

Use a solid ground plane to help reduce electromagnetic interference (EMI) noise pickup.

Do not run sensitive analog traces in parallel with digital traces. Avoid crossing digital and analog traces if possible, and only make perpendicular crossings when necessary.

10.2 Layout Example

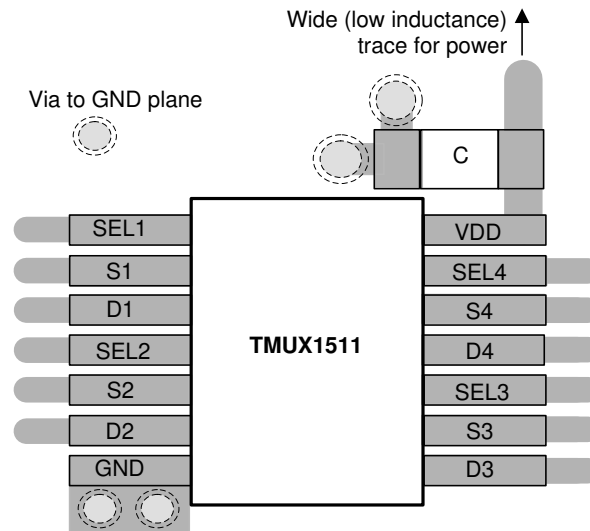

Figure 10-3. Example Layout

11 Device and Documentation Support

11.1 Third-Party Products Disclaimer

TI'S PUBLICATION OF INFORMATION REGARDING THIRD-PARTY PRODUCTS OR SERVICES DOES NOT CONSTITUTE AN ENDORSEMENT REGARDING THE SUITABILITY OF SUCH PRODUCTS OR SERVICES OR A WARRANTY, REPRESENTATION OR ENDORSEMENT OF SUCH PRODUCTS OR SERVICES, EITHER ALONE OR IN COMBINATION WITH ANY TI PRODUCT OR SERVICE.

11.2 Documentation Support

11.2.1 Related Documentation

- Texas Instruments, [Improve Stability Issues with Low CON Multiplexers](#)
- Texas Instruments, [Simplifying Design with 1.8 V logic Muxes and Switches](#)
- Texas Instruments, [Eliminate Power Sequencing with Powered-off Protection Signal Switches](#)
- Texas Instruments, [High-Speed Interface Layout Guidelines](#)
- Texas Instruments, [High-Speed Layout Guidelines](#)
- Texas Instruments, [QFN/SON PCB Attachment](#)
- Texas Instruments, [Quad Flatpack No-Lead Logic Packages](#)

11.3 Receiving Notification of Documentation Updates

To receive notification of documentation updates, navigate to the device product folder on ti.com. In the upper right corner, click on *Alert me* to register and receive a weekly digest of any product information that has changed. For change details, review the revision history included in any revised document.

11.4 Support Resources

[TI E2E™ support forums](#) are an engineer's go-to source for fast, verified answers and design help — straight from the experts. Search existing answers or ask your own question to get the quick design help you need.

Linked content is provided "AS IS" by the respective contributors. They do not constitute TI specifications and do not necessarily reflect TI's views; see TI's [Terms of Use](#).

11.5 Trademarks

TI E2E™ is a trademark of Texas Instruments.

All trademarks are the property of their respective owners.

11.6 Electrostatic Discharge Caution



This integrated circuit can be damaged by ESD. Texas Instruments recommends that all integrated circuits be handled with appropriate precautions. Failure to observe proper handling and installation procedures can cause damage.

ESD damage can range from subtle performance degradation to complete device failure. Precision integrated circuits may be more susceptible to damage because very small parametric changes could cause the device not to meet its published specifications.

11.7 Glossary

[TI Glossary](#) This glossary lists and explains terms, acronyms, and definitions.

12 Revision History

NOTE: Page numbers for previous revisions may differ from page numbers in the current version.

Changes from Revision A (December 2018) to Revision B (March 2025)	Page
• Added RWB Package.....	4

Changes from Revision * (September 2018) to Revision A (December 2018)	Page
• Changed the data sheet status From: <i>Advanced Information</i> To <i>Production</i> data	1

13 Mechanical, Packaging, and Orderable Information

The following pages include mechanical, packaging, and orderable information. This information is the most current data available for the designated devices. This data is subject to change without notice and revision of this document. For browser-based versions of this data sheet, refer to the left-hand navigation.

PACKAGING INFORMATION

Orderable part number	Status (1)	Material type (2)	Package Pins	Package qty Carrier	RoHS (3)	Lead finish/ Ball material (4)	MSL rating/ Peak reflow (5)	Op temp (°C)	Part marking (6)
TMUX1511PWR	Active	Production	TSSOP (PW) 14	2000 LARGE T&R	Yes	NIPDAU SN	Level-1-260C-UNLIM	-40 to 125	MUX1511
TMUX1511PWR.A	Active	Production	TSSOP (PW) 14	2000 LARGE T&R	Yes	NIPDAU	Level-1-260C-UNLIM	-40 to 125	MUX1511
TMUX1511PWRG4	Active	Production	TSSOP (PW) 14	2000 LARGE T&R	Yes	NIPDAU	Level-1-260C-UNLIM	-40 to 125	MUX1511
TMUX1511PWRG4.A	Active	Production	TSSOP (PW) 14	2000 LARGE T&R	Yes	NIPDAU	Level-1-260C-UNLIM	-40 to 125	MUX1511
TMUX1511RSVR	Active	Production	UQFN (RSV) 16	3000 LARGE T&R	Yes	NIPDAU	Level-1-260C-UNLIM	-40 to 125	1511
TMUX1511RSVR.A	Active	Production	UQFN (RSV) 16	3000 LARGE T&R	Yes	NIPDAU	Level-1-260C-UNLIM	-40 to 125	1511
TMUX1511RSVRG4.A	Active	Production	UQFN (RSV) 16	3000 LARGE T&R	Yes	NIPDAU	Level-1-260C-UNLIM	-40 to 125	1511
TMUX1511RWBR	Active	Production	X2QFN (RWB) 12	3000 LARGE T&R	Yes	NIPDAU	Level-1-260C-UNLIM	-40 to 125	QZ
TMUX1511RWBR.A	Active	Production	X2QFN (RWB) 12	3000 LARGE T&R	Yes	NIPDAU	Level-1-260C-UNLIM	-40 to 125	QZ

(1) **Status:** For more details on status, see our [product life cycle](#).

(2) **Material type:** When designated, preproduction parts are prototypes/experimental devices, and are not yet approved or released for full production. Testing and final process, including without limitation quality assurance, reliability performance testing, and/or process qualification, may not yet be complete, and this item is subject to further changes or possible discontinuation. If available for ordering, purchases will be subject to an additional waiver at checkout, and are intended for early internal evaluation purposes only. These items are sold without warranties of any kind.

(3) **RoHS values:** Yes, No, RoHS Exempt. See the [TI RoHS Statement](#) for additional information and value definition.

(4) **Lead finish/Ball material:** Parts may have multiple material finish options. Finish options are separated by a vertical ruled line. Lead finish/Ball material values may wrap to two lines if the finish value exceeds the maximum column width.

(5) **MSL rating/Peak reflow:** The moisture sensitivity level ratings and peak solder (reflow) temperatures. In the event that a part has multiple moisture sensitivity ratings, only the lowest level per JEDEC standards is shown. Refer to the shipping label for the actual reflow temperature that will be used to mount the part to the printed circuit board.

(6) **Part marking:** There may be an additional marking, which relates to the logo, the lot trace code information, or the environmental category of the part.

Multiple part markings will be inside parentheses. Only one part marking contained in parentheses and separated by a "-" will appear on a part. If a line is indented then it is a continuation of the previous line and the two combined represent the entire part marking for that device.

Important Information and Disclaimer: The information provided on this page represents TI's knowledge and belief as of the date that it is provided. TI bases its knowledge and belief on information provided by third parties, and makes no representation or warranty as to the accuracy of such information. Efforts are underway to better integrate information from third parties. TI has taken and continues to take reasonable steps to provide representative

and accurate information but may not have conducted destructive testing or chemical analysis on incoming materials and chemicals. TI and TI suppliers consider certain information to be proprietary, and thus CAS numbers and other limited information may not be available for release.

In no event shall TI's liability arising out of such information exceed the total purchase price of the TI part(s) at issue in this document sold by TI to Customer on an annual basis.

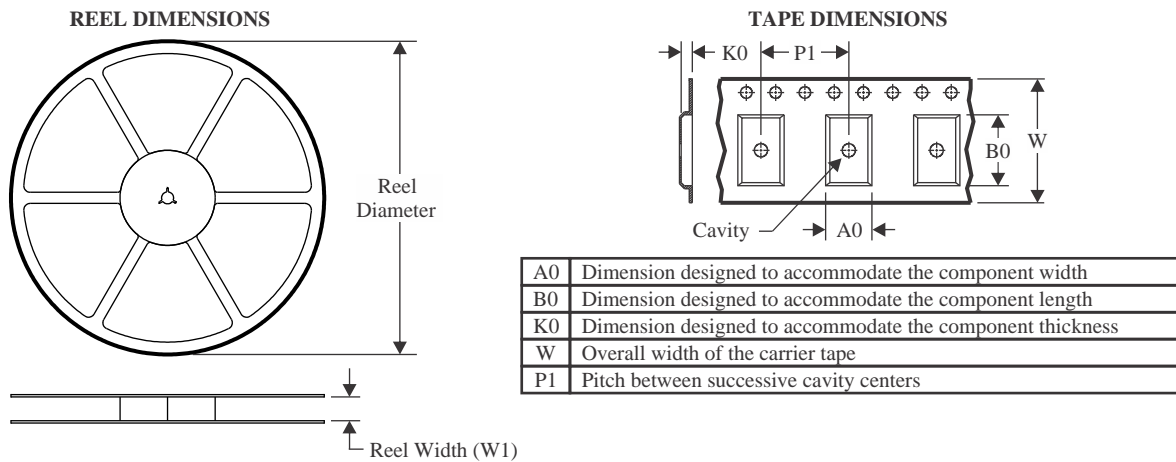
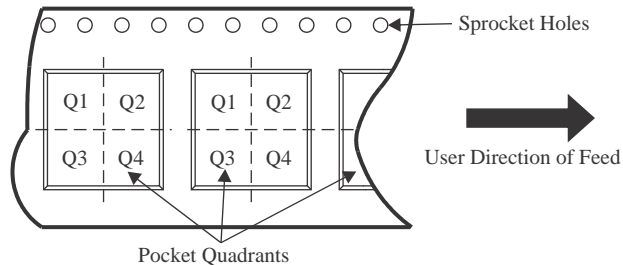
TAPE AND REEL INFORMATION

QUADRANT ASSIGNMENTS FOR PIN 1 ORIENTATION IN TAPE

*All dimensions are nominal

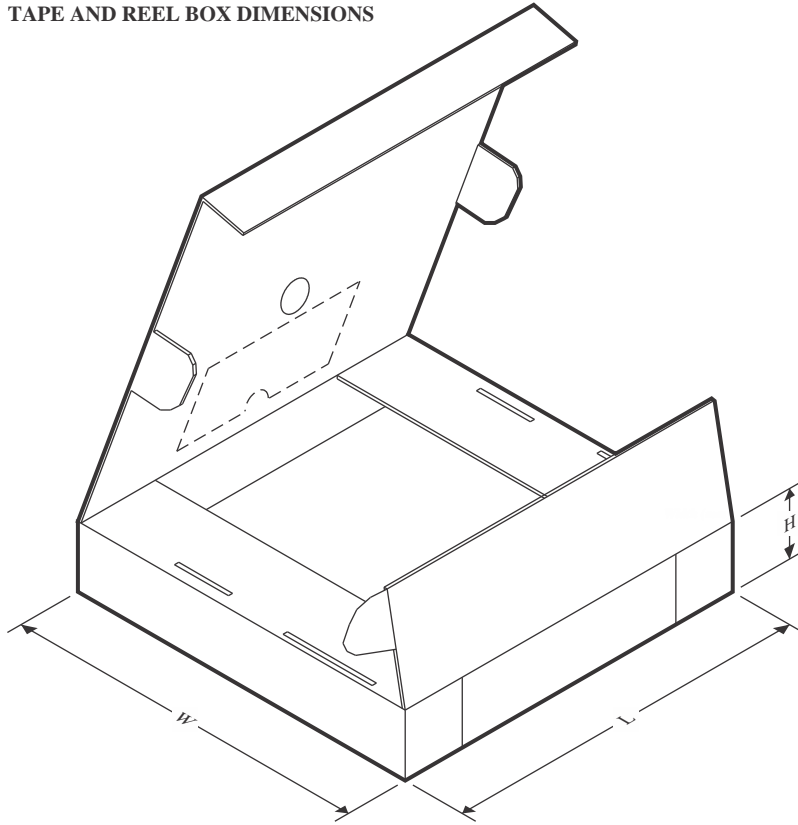
Device	Package Type	Package Drawing	Pins	SPQ	Reel Diameter (mm)	Reel Width W1 (mm)	A0 (mm)	B0 (mm)	K0 (mm)	P1 (mm)	W (mm)	Pin1 Quadrant
TMUX1511PWR	TSSOP	PW	14	2000	330.0	12.4	6.9	5.6	1.6	8.0	12.0	Q1
TMUX1511PWR	TSSOP	PW	14	2000	330.0	12.4	6.9	5.6	1.6	8.0	12.0	Q1
TMUX1511PWRG4	TSSOP	PW	14	2000	330.0	12.4	6.9	5.6	1.6	8.0	12.0	Q1
TMUX1511RSVR	UQFN	RSV	16	3000	178.0	13.5	2.1	2.9	0.75	4.0	12.0	Q1
TMUX1511RWBR	X2QFN	RWB	12	3000	180.0	8.4	1.8	1.8	0.48	4.0	8.0	Q2

TAPE AND REEL BOX DIMENSIONS

*All dimensions are nominal

Device	Package Type	Package Drawing	Pins	SPQ	Length (mm)	Width (mm)	Height (mm)
TMUX1511PWR	TSSOP	PW	14	2000	353.0	353.0	32.0
TMUX1511PWR	TSSOP	PW	14	2000	356.0	356.0	35.0
TMUX1511PWRG4	TSSOP	PW	14	2000	353.0	353.0	32.0
TMUX1511RSVR	UQFN	RSV	16	3000	189.0	185.0	36.0
TMUX1511RWBR	X2QFN	RWB	12	3000	210.0	185.0	35.0

GENERIC PACKAGE VIEW

RSV 16

UQFN - 0.55 mm max height

1.8 x 2.6, 0.4 mm pitch

ULTRA THIN QUAD FLATPACK - NO LEAD

This image is a representation of the package family, actual package may vary.
Refer to the product data sheet for package details.

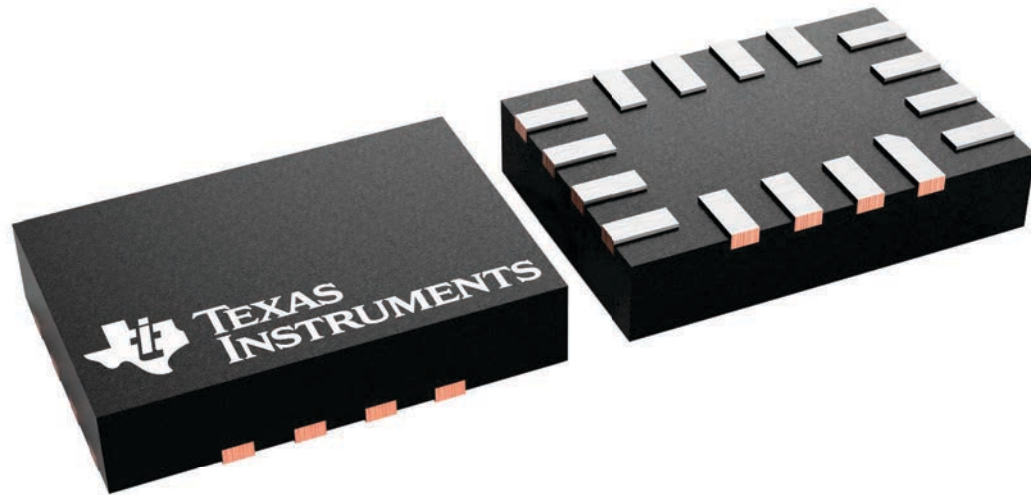

4231225/A

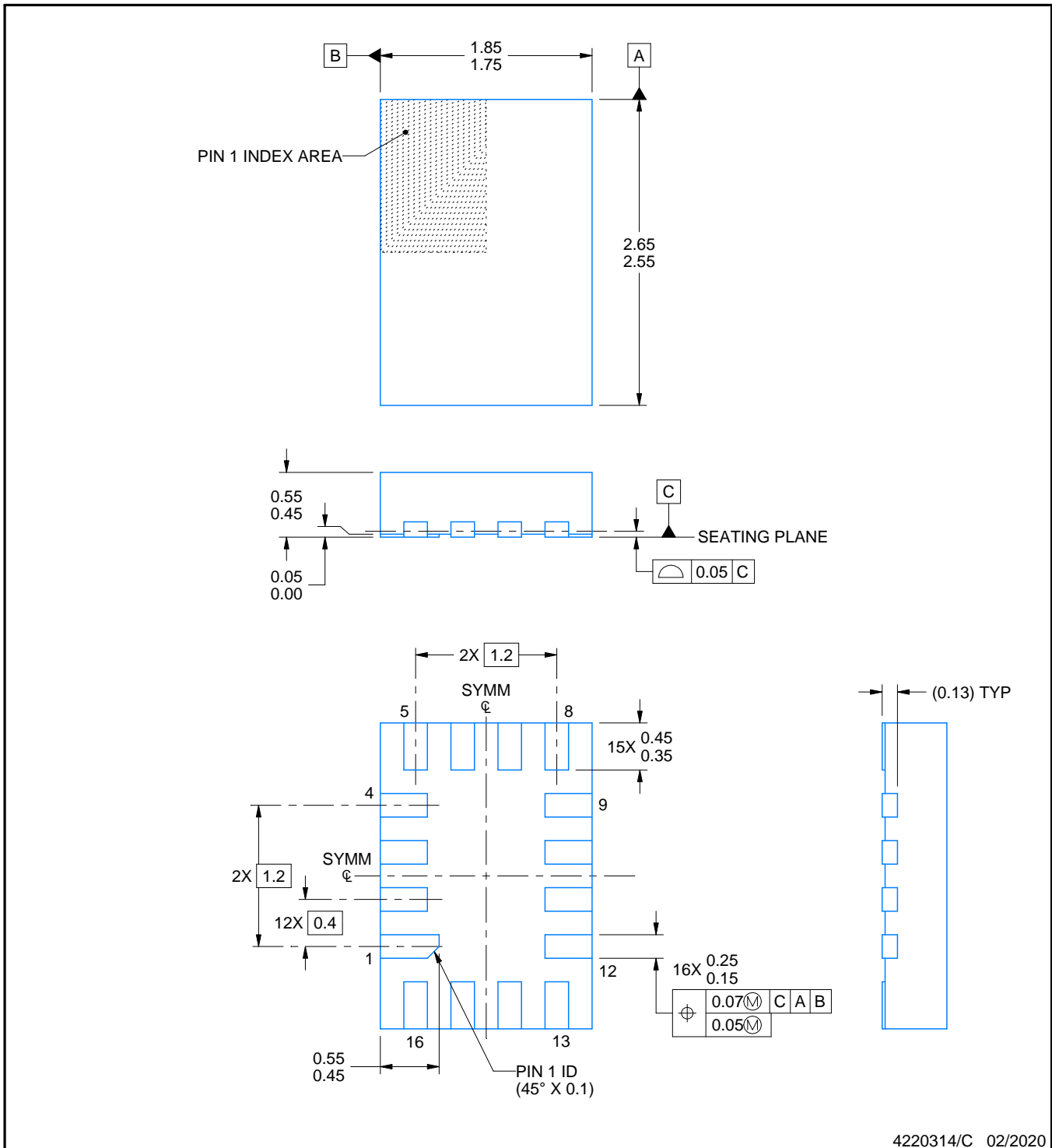
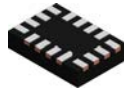

4220314/C 02/2020

NOTES:

1. All linear dimensions are in millimeters. Any dimensions in parenthesis are for reference only. Dimensioning and tolerancing per ASME Y14.5M.
2. This drawing is subject to change without notice.

EXAMPLE BOARD LAYOUT

RSV0016A

UQFN - 0.55 mm max height

ULTRA THIN QUAD FLATPACK - NO LEAD

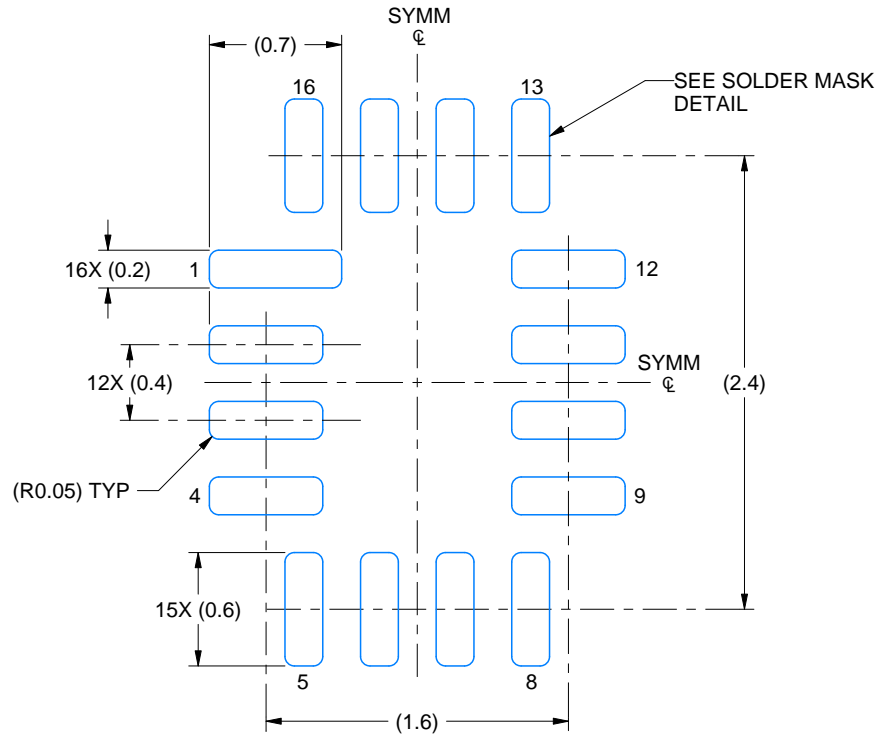

LAND PATTERN EXAMPLE
EXPOSED METAL SHOWN
SCALE: 25X

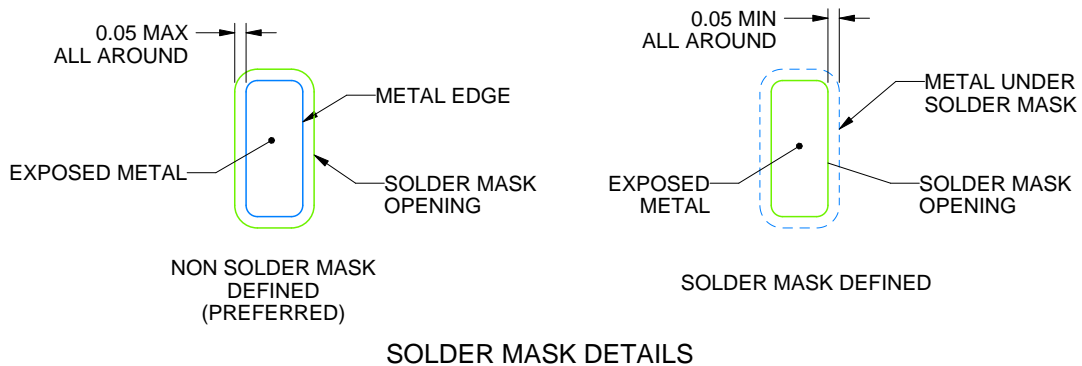

4220314/C 02/2020

NOTES: (continued)

3. For more information, see Texas Instruments literature number SLUA271 (www.ti.com/lit/slua271).

EXAMPLE STENCIL DESIGN

RSV0016A

UQFN - 0.55 mm max height

ULTRA THIN QUAD FLATPACK - NO LEAD

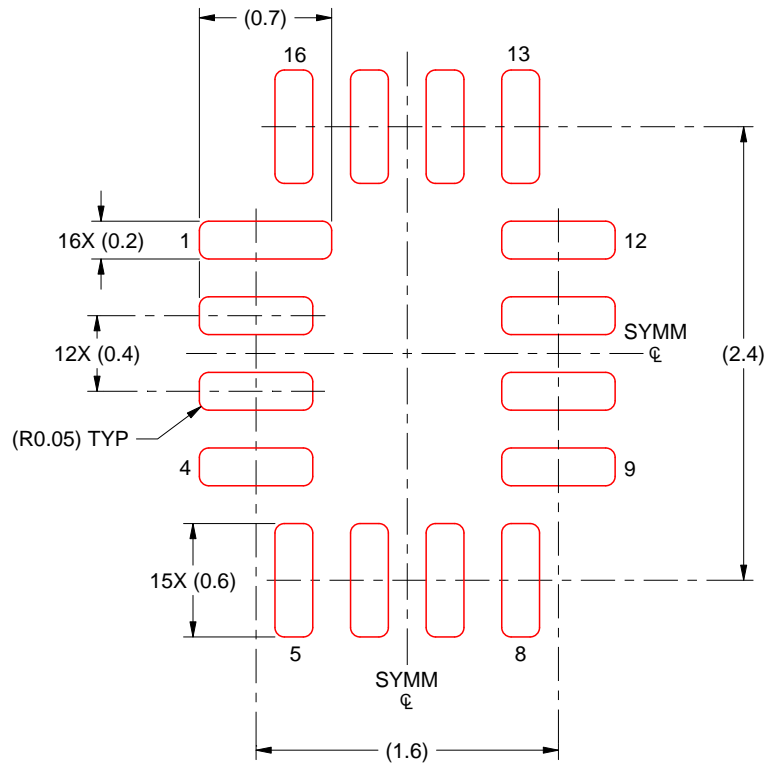

SOLDER PASTE EXAMPLE
BASED ON 0.125 MM THICK STENCIL
SCALE: 25X

4220314/C 02/2020

NOTES: (continued)

4. Laser cutting apertures with trapezoidal walls and rounded corners may offer better paste release. IPC-7525 may have alternate design recommendations.

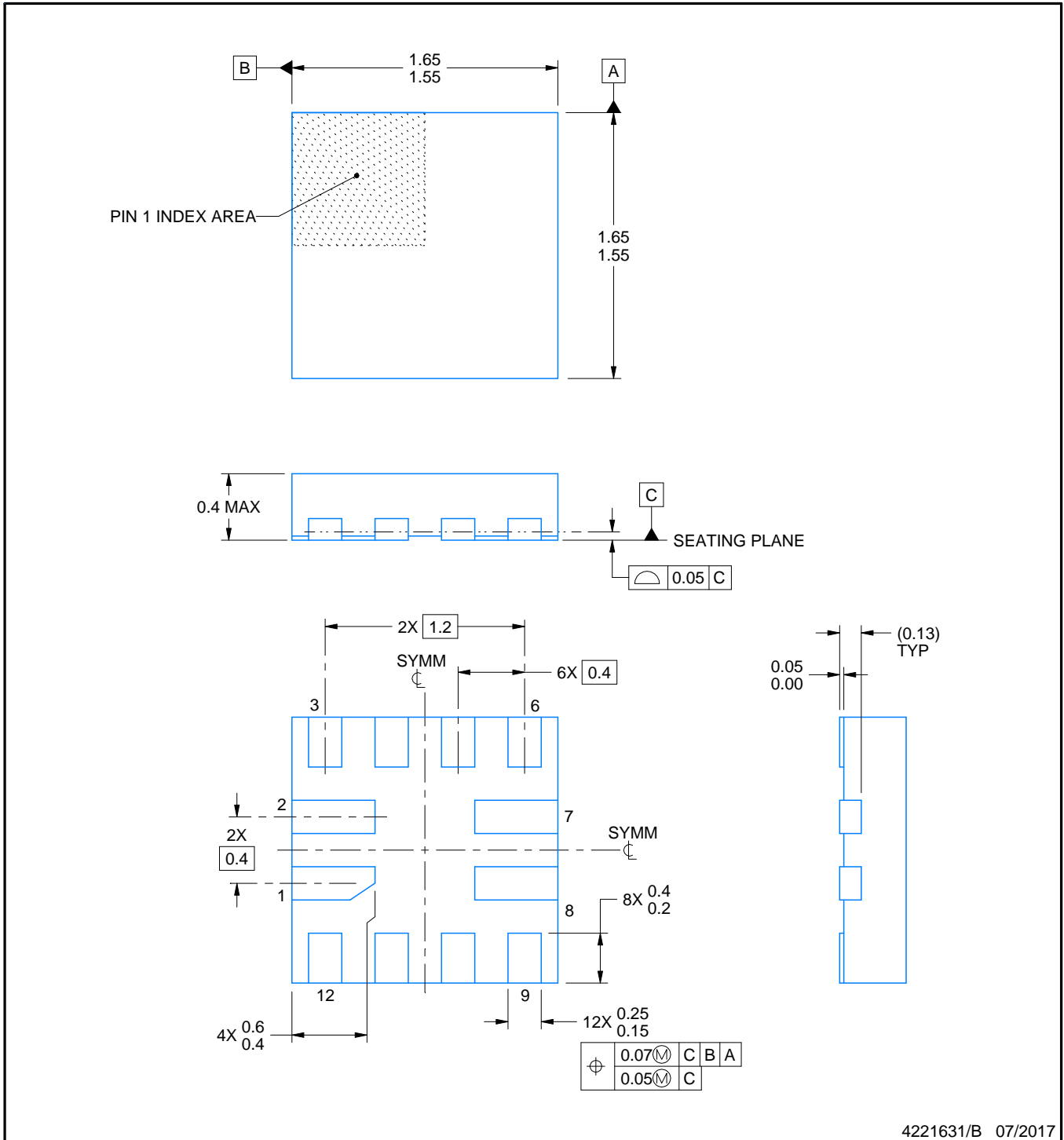
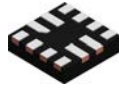

4221631/B 07/2017

NOTES:

1. All linear dimensions are in millimeters. Any dimensions in parenthesis are for reference only. Dimensioning and tolerancing per ASME Y14.5M.
2. This drawing is subject to change without notice.

EXAMPLE BOARD LAYOUT

RWB0012A

X2QFN - 0.4 mm max height

PLASTIC QUAD FLATPACK - NO LEAD

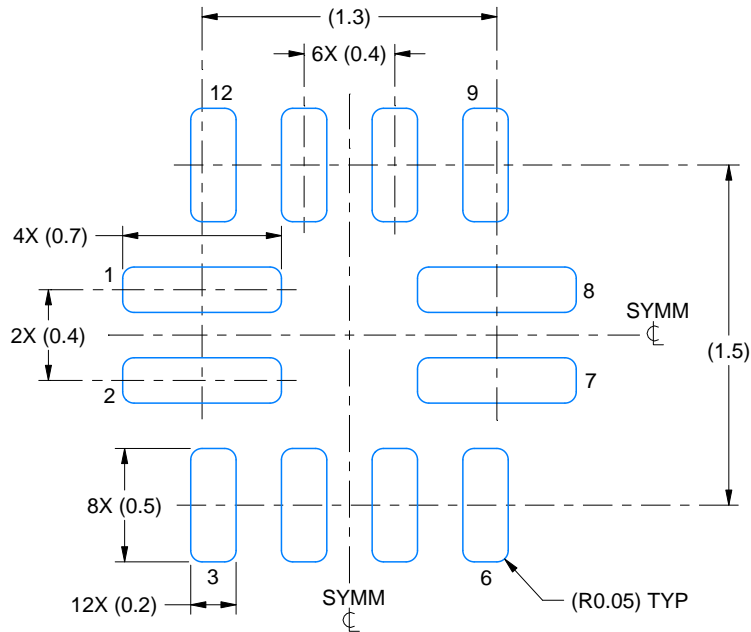

LAND PATTERN EXAMPLE
EXPOSED METAL SHOWN
SCALE:30X

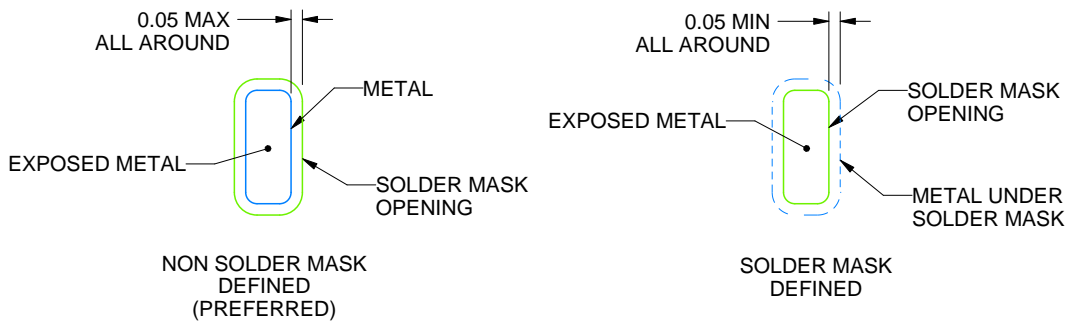

SOLDER MASK DETAILS

4221631/B 07/2017

NOTES: (continued)

3. For more information, see Texas Instruments literature number SLUA271 (www.ti.com/lit/slua271).

EXAMPLE STENCIL DESIGN

RWB0012A

X2QFN - 0.4 mm max height

PLASTIC QUAD FLATPACK - NO LEAD

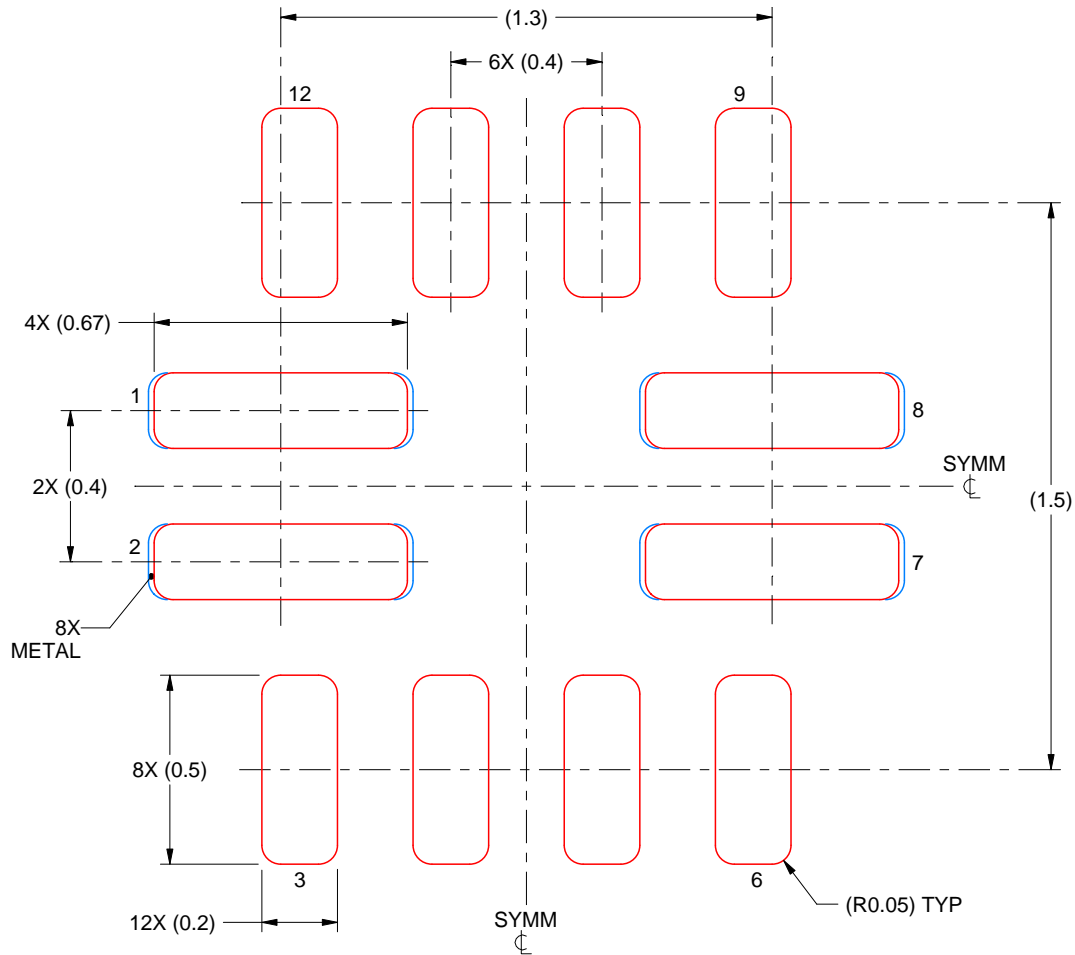

SOLDER PASTE EXAMPLE
BASED ON 0.1 mm THICK STENCIL
PADS 1,2,7 & 8
96% PRINTED SOLDER COVERAGE BY AREA
SCALE:50X

4221631/B 07/2017

NOTES: (continued)

4. Laser cutting apertures with trapezoidal walls and rounded corners may offer better paste release. IPC-7525 may have alternate design recommendations.

PW0014A

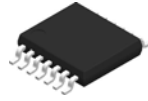

PACKAGE OUTLINE
TSSOP - 1.2 mm max height

SMALL OUTLINE PACKAGE

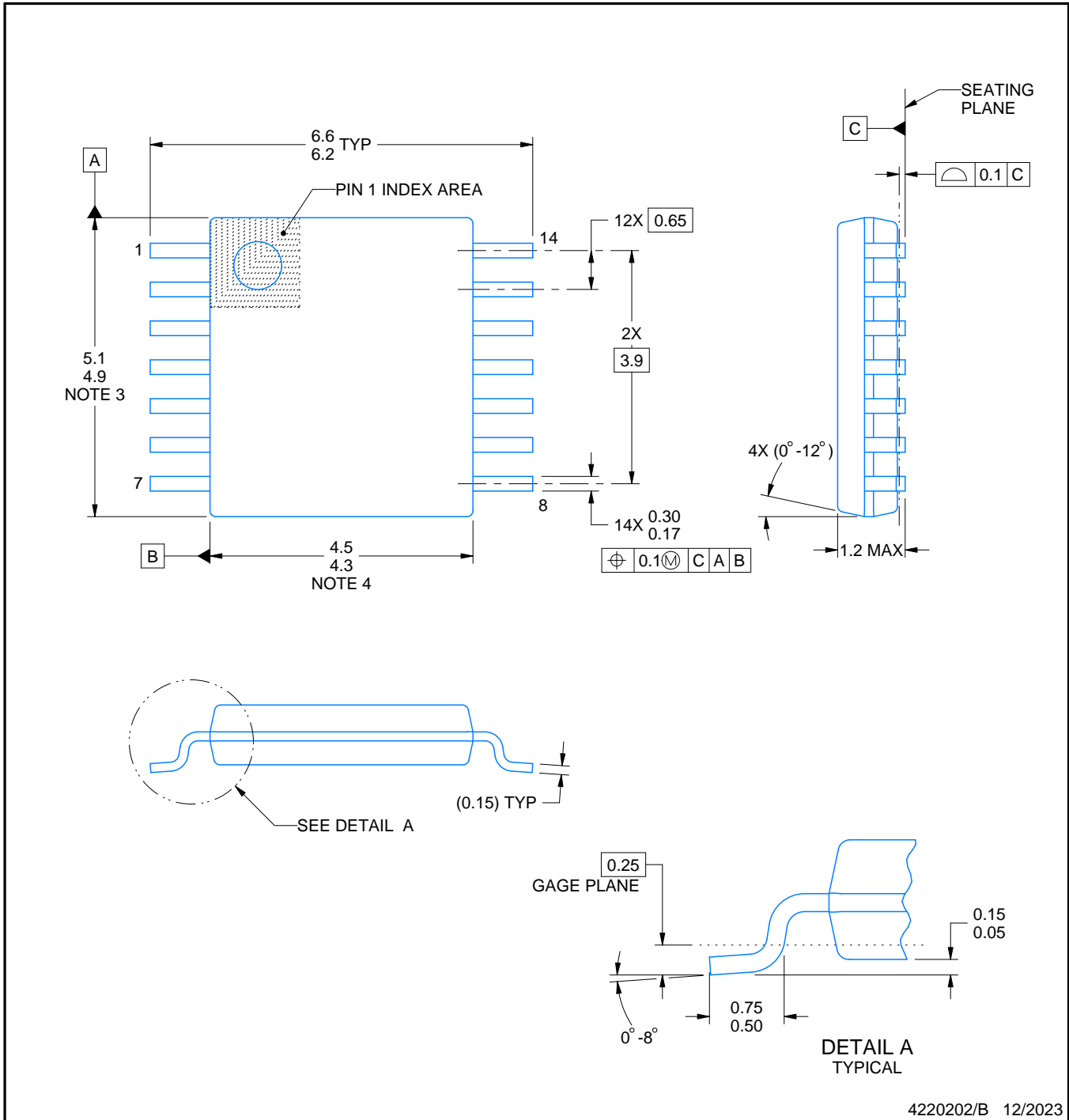

NOTES:

1. All linear dimensions are in millimeters. Any dimensions in parenthesis are for reference only. Dimensioning and tolerancing per ASME Y14.5M.
2. This drawing is subject to change without notice.
3. This dimension does not include mold flash, protrusions, or gate burrs. Mold flash, protrusions, or gate burrs shall not exceed 0.15 mm per side.
4. This dimension does not include interlead flash. Interlead flash shall not exceed 0.25 mm per side.
5. Reference JEDEC registration MO-153.

EXAMPLE BOARD LAYOUT

PW0014A

TSSOP - 1.2 mm max height

SMALL OUTLINE PACKAGE

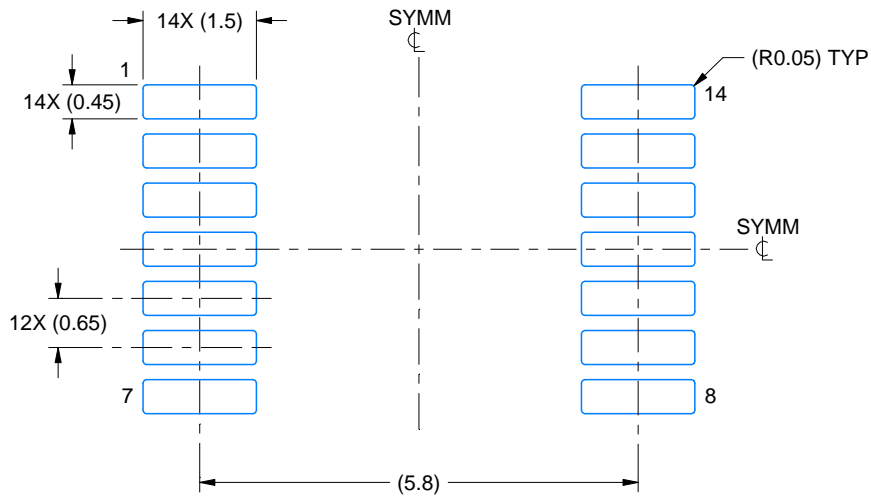

LAND PATTERN EXAMPLE
EXPOSED METAL SHOWN
SCALE: 10X

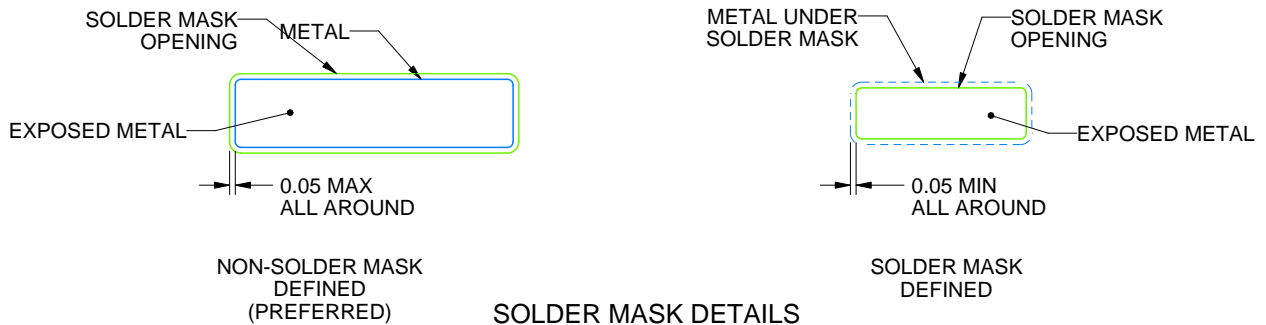

4220202/B 12/2023

NOTES: (continued)

6. Publication IPC-7351 may have alternate designs.
7. Solder mask tolerances between and around signal pads can vary based on board fabrication site.

EXAMPLE STENCIL DESIGN

PW0014A

TSSOP - 1.2 mm max height

SMALL OUTLINE PACKAGE

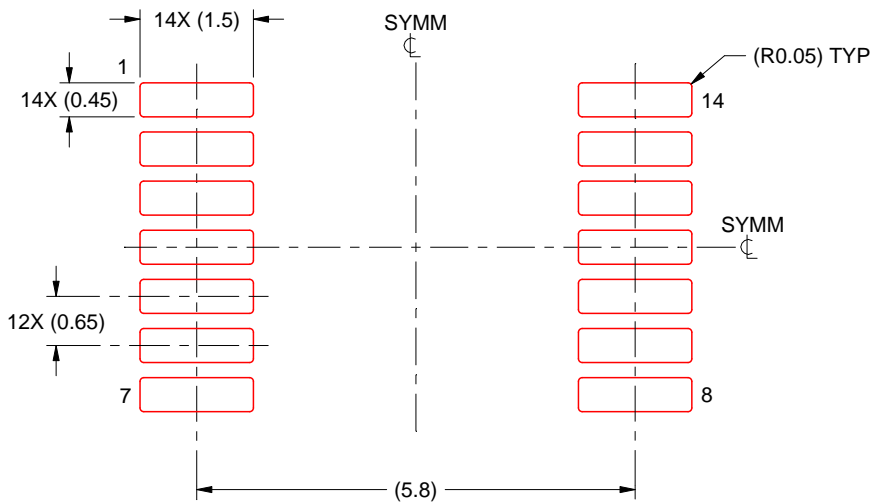

SOLDER PASTE EXAMPLE
BASED ON 0.125 mm THICK STENCIL
SCALE: 10X

4220202/B 12/2023

NOTES: (continued)

8. Laser cutting apertures with trapezoidal walls and rounded corners may offer better paste release. IPC-7525 may have alternate design recommendations.
9. Board assembly site may have different recommendations for stencil design.

IMPORTANT NOTICE AND DISCLAIMER

TI PROVIDES TECHNICAL AND RELIABILITY DATA (INCLUDING DATASHEETS), DESIGN RESOURCES (INCLUDING REFERENCE DESIGNS), APPLICATION OR OTHER DESIGN ADVICE, WEB TOOLS, SAFETY INFORMATION, AND OTHER RESOURCES "AS IS" AND WITH ALL FAULTS, AND DISCLAIMS ALL WARRANTIES, EXPRESS AND IMPLIED, INCLUDING WITHOUT LIMITATION ANY IMPLIED WARRANTIES OF MERCHANTABILITY, FITNESS FOR A PARTICULAR PURPOSE OR NON-INFRINGEMENT OF THIRD PARTY INTELLECTUAL PROPERTY RIGHTS.

These resources are intended for skilled developers designing with TI products. You are solely responsible for (1) selecting the appropriate TI products for your application, (2) designing, validating and testing your application, and (3) ensuring your application meets applicable standards, and any other safety, security, regulatory or other requirements.

These resources are subject to change without notice. TI grants you permission to use these resources only for development of an application that uses the TI products described in the resource. Other reproduction and display of these resources is prohibited. No license is granted to any other TI intellectual property right or to any third party intellectual property right. TI disclaims responsibility for, and you fully indemnify TI and its representatives against any claims, damages, costs, losses, and liabilities arising out of your use of these resources.

TI's products are provided subject to [TI's Terms of Sale](#), [TI's General Quality Guidelines](#), or other applicable terms available either on ti.com or provided in conjunction with such TI products. TI's provision of these resources does not expand or otherwise alter TI's applicable warranties or warranty disclaimers for TI products. Unless TI explicitly designates a product as custom or customer-specified, TI products are standard, catalog, general purpose devices.

TI objects to and rejects any additional or different terms you may propose.

Copyright © 2026, Texas Instruments Incorporated

Last updated 10/2025