

TMUXHS4212 Two-Channel Differential 2:1 MUX or 1:2 Demux

1 Features

- Provides bidirectional 2:1 mux or 1:2 demux
- Supports USB 3.2 up to 10 Gbps (Gen 2.0) and PCI Express up to 16 Gbps (Gen 4.0)
- Also supports SATA, SAS, Mipi® DSI/CSI, FPD-Link III, LVDS, SFI and Ethernet® interfaces
- -3-dB differential BW of 13 GHz
- Dynamic characteristics:
 - Insertion loss = -1.3 / -1.8 dB at 5 / 8 Ghz
 - Return loss = -13/ -12 dB at 5 / 8 Ghz
 - Off isolation = -22 / -20 dB at 5 / 8 Ghz
- Adaptive common mode voltage tracking
- Supports common mode voltage up to 0 to 1.8 V
- Single supply voltage V_{CC} of 3.3 or 1.8 V
- Ultra low active (180 μA) and standby power consumption (< 2 μA)
- Industrial temperature option with -40° to 105°C
- Available in 2.5 mm × 4.5 mm QFN package

2 Applications

- [PC and notebooks](#)
- [Smartphone, tablets, and TV](#)
- [Gaming, home theater, and entertainment](#)
- [Data center and enterprise computing](#)
- [Medical applications](#)
- [Test and measurements](#)
- [Factory automation and control](#)
- [Aerospace and defense](#)
- [Electronic point of sale \(EPOS\)](#)
- [Wireless infrastructure](#)

3 Description

The TMUXHS4212 is a high-speed bidirectional passive switch in mux or demux configurations. It is suited for many applications including USB Type-C™ and PCI Express. The TMUXHS4212 is a generic analog differential passive mux or demux that works for many high-speed differential interfaces with data rates up to 16 Gbps. The device can be used for higher data rates where the electrical channel has signal integrity margins. The TMUXHS4212 supports differential signaling with common mode voltage range (CMV) of up to 0 to 1.8 V and with differential amplitude up to 1800 mVpp. Adaptive CMV tracking ensures the channel through the device remains unchanged for the entire common mode voltage range.

The dynamic characteristics of the TMUXHS4212 allows high-speed switching, minimum attenuation to the signal eye diagram, and with very little added jitter. The device's silicon design is optimized for excellent frequency response at higher frequency spectrum of the signals. Its silicon signal traces and switch network are matched for best intra-pair skew performance.

The TMUXHS4212 has an extended industrial temperature range that suits many rugged applications including industrial and high reliability use cases.

Device Information⁽¹⁾

PART NUMBER	PACKAGE	BODY SIZE (NOM)
TMUXHS4212	VQFN (20)	2.50 mm × 4.50 mm × 0.5-mm pitch
TMUXHS4212I		

(1) For all available packages, see the orderable addendum at the end of the data sheet.

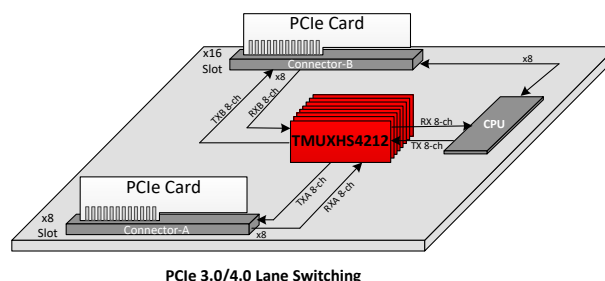
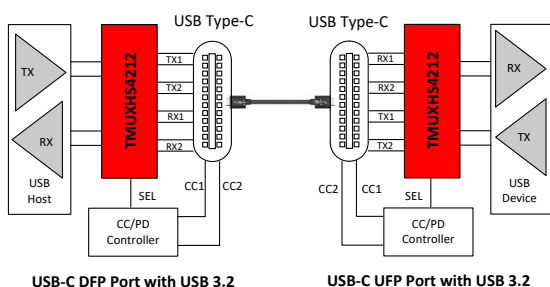

Application Use Cases



Table of Contents

1 Features	1	8.3 Feature Description.....	9
2 Applications	1	8.4 Device Functional Modes.....	10
3 Description	1	9 Application and Implementation	11
4 Revision History	2	9.1 Application Information.....	11
5 Pin Configuration and Functions	3	9.2 Typical Applications.....	13
6 Specifications	4	9.3 Systems Examples.....	18
6.1 Absolute Maximum Ratings.....	4	10 Power Supply Recommendations	18
6.2 ESD Ratings.....	4	11 Layout	19
6.3 Recommended Operating Conditions.....	4	11.1 Layout Guidelines.....	19
6.4 Thermal Information.....	4	11.2 Layout Example.....	19
6.5 Electrical Characteristics.....	5	12 Device and Documentation Support	20
6.6 High-Speed Performance Parameters.....	5	12.1 Receiving Notification of Documentation Updates.....	20
6.7 Switching Characteristics.....	6	12.2 Support Resources.....	20
6.8 Typical Characteristics.....	7	12.3 Trademarks.....	20
7 Parameter Measurement Information	8	12.4 Electrostatic Discharge Caution.....	20
8 Detailed Description	9	12.5 Glossary.....	20
8.1 Overview.....	9	13 Mechanical, Packaging, and Orderable Information	20
8.2 Functional Block Diagram.....	9		

4 Revision History

NOTE: Page numbers for previous revisions may differ from page numbers in the current version.

Changes from Revision * (May 2020) to Revision A (May 2022)	Page
• Updated the numbering format for tables, figures, and cross-references throughout the document.....	1
• Updated the <i>single supply voltage</i> V_{CC} in the Features section.....	1
• Updated the <i>RSVD1</i> and <i>RSVD2</i> description.....	3
• Changed single supply voltage V_{CC} from: 3.3 V to: 3.3 or 1.8 V	3

5 Pin Configuration and Functions

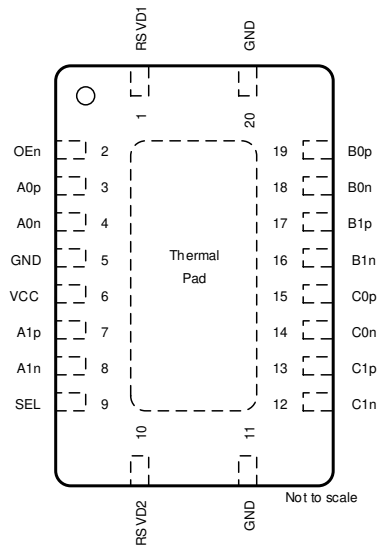

Figure 5-1. RKS Package, 20-Pin VQFN (Top View)

Table 5-1. Pin Functions

PIN		TYPE ⁽¹⁾	DESCRIPTION
NAME	NO.		
A0n	4	I/O	Port A, channel 0, high-speed negative signal
A0p	3	I/O	Port A, channel 0, high-speed positive signal
A1n	8	I/O	Port A, channel 1, high-speed negative signal
A1p	7	I/O	Port A, channel 1, high-speed positive signal
B0n	18	I/O	Port B, channel 0, high-speed negative signal (connector side)
B0p	19	I/O	Port B, channel 0, high-speed positive signal (connector side)
B1n	16	I/O	Port B, channel 1, high-speed negative signal
B1p	17	I/O	Port B, channel 1, high-speed positive signal
C0n	14	I/O	Port C, channel 0, high-speed negative signal
C0p	15	I/O	Port C, channel 0, high-speed positive signal
C1n	12	I/O	Port C, channel 1, high-speed negative signal
C1p	13	I/O	Port C, channel 1, high-speed positive signal
GND	5, 11, 20	G	Ground
OEn	2	I	Active-low chip enable. The pin can be connected to GND if always on functional behavior is desired. L: Normal operation, H: Shutdown. If always ON, behavior of the device is desired. The pin can be permanently connected to GND.
RSVD1	1	NA	Reserved pins. Connect both pins to V _{CC}
RSVD2	10	NA	
SEL	9	I	Port select pin. L: Port A to Port B, H: Port A to Port C
V _{CC}	6	P	3.3 V or 1.8 V power

(1) I = input, O = output, G = ground, P = power

6 Specifications

6.1 Absolute Maximum Ratings

over operating free-air temperature range (unless otherwise noted)⁽¹⁾

		MIN	MAX	UNIT	
V _{CC-ABS} MAX	Supply voltage	-0.5	4	V	
V _{HS-ABS} MAX	Voltage	Differential I/O	-0.5	2.4	V
V _{CTR-ABS} MAX	Voltage	Control pins	-0.5	V _{CC} +0.4	V
T _{STG}	Storage temperature	-65	150	°C	

- (1) Stresses beyond those listed under *Absolute Maximum Ratings* may cause permanent damage to the device. These are stress ratings only, which do not imply functional operation of the device at these or any other conditions beyond those indicated under *Recommended Operating Conditions*. Exposure to absolute-maximum-rated conditions for extended periods may affect device reliability.

6.2 ESD Ratings

		VALUE	UNIT
V _{ESD}	Electrostatic discharge	Human-body model (HBM), per ANSI/ESDA/JEDEC JS-001 ⁽¹⁾	±2000
		Charged-device model (CDM), per JEDEC specification JESD22-C101 ⁽²⁾	±1000

- (1) JEDEC document JEP155 states that 500-V HBM allows safe manufacturing with a standard ESD control process.
 (2) JEDEC document JEP157 states that 250-V CDM allows safe manufacturing with a standard ESD control process.

6.3 Recommended Operating Conditions

over operating free-air temperature range (unless otherwise noted)

		MIN	TYP	MAX	UNIT	
V _{CC}	Supply Voltage	1.8 V mode	1.71	1.8	1.98	V
		3.3 V mode	3.0	3.3	3.6	V
V _{CC-RAMP}	Supply voltage ramp time	0.1		100	ms	
V _{IH}	Input high voltage	SEL, OEn pins	0.75 V _{CC}		V	
V _{IL}	Input low voltage	SEL, OEn pins		0.25 V _{CC}	V	
V _{DIFF}	High-speed signal pins differential voltage	0		1.8	V _{pp}	
V _{CM}	High speed signal pins common mode voltage	VCC 1.8 V mode	0	1.2	V	
		VCC 3.3 V mode	0	1.8	V	
T _A	Operating free-air/ambient temperature	TMUXHS4212	0	70	°C	
		TMUXHS4212I	-40	105	°C	

6.4 Thermal Information

THERMAL METRIC ⁽¹⁾		TMUXHS4212	UNIT
		RKS (VQFN)	
		20 PINS	
R _{θJA}	Junction-to-ambient thermal resistance - High K	53.0	°C/W
R _{θJC(top)}	Junction-to-case (top) thermal resistance	52.3	°C/W
R _{θJB}	Junction-to-board thermal resistance	27.1	°C/W
ψ _{JT}	Junction-to-top characterization parameter	2.9	°C/W
ψ _{JB}	Junction-to-board characterization parameter	26.9	°C/W
R _{θJC(bot)}	Junction-to-case (bottom) thermal resistance	11.1	°C/W

- (1) For more information about traditional and new thermal metrics, see the [Semiconductor and IC Package Thermal Metrics](#) application report.

6.5 Electrical Characteristics

over operating free-air temperature and supply voltage range (unless otherwise noted)

PARAMETER		TEST CONDITIONS	MIN	TYP	MAX	UNIT
I _{CC}	Device active current	OEn = 0; 0 V ≤ V _{CM} ≤ 1.8; SEL = 0 or V _{CC}		180	250	μA
I _{STDN}	Device shutdown current	OEn = V _{CC}		2	5	μA
C _{ON}	Output ON capacitance to GND	OEn = 0			0.6	pF
R _{ON}	Output ON resistance	0 V ≤ V _{CM} ≤ 1.8 V; I _O = -8 mA		5	8.4	Ω
ΔR _{ON}	On-resistance match between pairs for the same channel at same V _{CM} , V _{CC} and T _A				0.5	Ω
R _{FLAT_ON}	On-resistance flatness R _{ON} (MAX) – R _{ON} (MIN) over V _{CM} range for the same channel at same V _{CC} and T _A				0.75	Ω
I _{IH,CTRL}	Input high current, control pins (SEL, OEn)	V _{IN} = V _{CC}			2	μA
I _{IL,CTRL}	Input low current, control pins (SEL, OEn)	V _{IN} = 0 V			1	μA
R _{CM,HS}	Common mode resistance to ground on Ax pins	Each pin to GND		1.0	1.6	MΩ
I _{IH,HS,SEL}	Input high current, high-speed pins [Ax/Bx/Cx][p/n]	V _{IN} = 1.8 V for selected port - A and B with SEL = 0, and A and C with SEL = V _{CC}			8	μA
I _{IH,HS,NSEL}	Input high current, high-speed pins [Ax/Bx/Cx][p/n]	V _{IN} = 1.8 V for non-selected port - C with SEL = 0, and B with SEL = V _{CC} ⁽¹⁾			150	μA
I _{IL,HS}	Input low current, high-speed pins [Ax/Bx/Cx][p/n]	V _{IN} = 0 V			1	μA
I _{HIZ,HS}	Leakage current through turned off switch between Ax[p/n] to [B]x[p/n] and [C]x[p/n]	OEn = V _{CC} ; Ax[p/n] = 1.8 V, [B and C]x[p/n] = 0 V and Ax[p/n] = 0 V, [B and C]x[p/n] = 1.8 V			5	μA
R _{A,p2n}	DC Impedance between p and n for Ax pins	OEn = 0 and V _{CC}		20		KΩ

(1) There is a 20-kΩ pull-down in non-selected port.

6.6 High-Speed Performance Parameters

PARAMETER	TEST CONDITION	MIN	TYP	MAX	UNIT
I _L	Differential insertion loss	f = 10 MHz		-0.5	dB
		f = 2.5 GHz		-0.8	
		f = 4 GHz		-1.1	
		f = 5 GHz		-1.3	
		f = 8 GHz		-1.8	
		f = 10 GHz		-2.1	
BW	-3-dB bandwidth		13		GHz
R _L	Differential return loss	f = 10 MHz		-28	dB
		f = 2.5 GHz		-17	
		f = 4 GHz		-13	
		f = 5 GHz		-13	
		f = 8 GHz		-12	
		f = 10 GHz		-12	
O _{IRR}	Differential OFF isolation	f = 10 MHz		-55	dB
		f = 2.5 GHz		-27	
		f = 4 GHz		-24	
		f = 5 GHz		-22	
		f = 8 GHz		-20	
		f = 10 GHz		-18	
X _{TALK}	Differential crosstalk	f = 10 MHz		-65	dB
		f = 2.5 GHz		-40	
		f = 4 GHz		-35	
		f = 5 GHz		-32	
		f = 8 GHz		-30	
		f = 10 GHz		-27	

6.6 High-Speed Performance Parameters (continued)

PARAMETER		TEST CONDITION	MIN	TYP	MAX	UNIT
SCD11,22	Mode conversion - differential to common mode	$f = 5 \text{ GHz}$		-29		dB
SCD21,12	Mode conversion - differential to common mode	$f = 5 \text{ GHz}$		-27		dB
SDC11,22	Mode conversion - common mode to differential	$f = 5 \text{ GHz}$		-29		dB
SDC21,12	Mode conversion - common mode to differential	$f = 5 \text{ GHz}$		-26		dB

6.7 Switching Characteristics

PARAMETER			MIN	TYP	MAX	UNIT
t_{PD}	Switch propagation delay	$f = 1 \text{ GHz}$			70	ps
$t_{SW_ON_CM_SHIFT}$	Switching time SEL-to-Switch ON	For different CMV			5	us
t_{SW_ON}	Switching time SEL-to-Switch ON	For same CMV			100	ns
$t_{SW_OFF_CM_SHIFT}$	Switching time SEL-to-Switch OFF	For different CMV			1	us
t_{SW_OFF}	Switching time SEL-to-Switch OFF	For same CMV			100	ns
t_{SK_INTRA}	Intra-pair output skew between P and N pins for same channel	$f = 1 \text{ GHz}$			8	ps
t_{SK_INTER}	Inter-pair output skew between channels	$f = 1 \text{ GHz}$			10	ps

6.8 Typical Characteristics

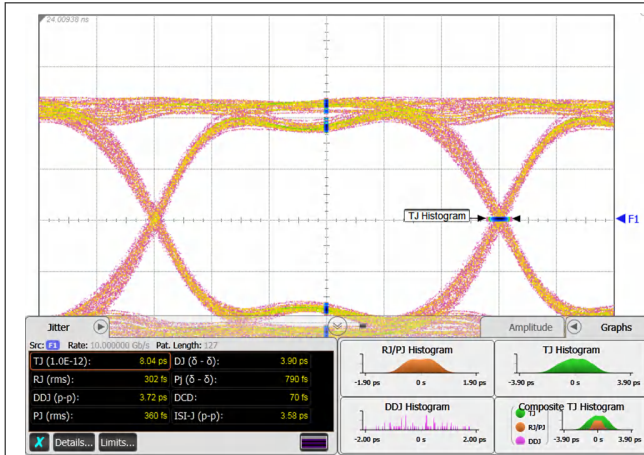

Figure 6-1. Jitter Decomposition of 10 Gbps PRBS-7 Signals Through Calibration Traces in TI Evaluation Board

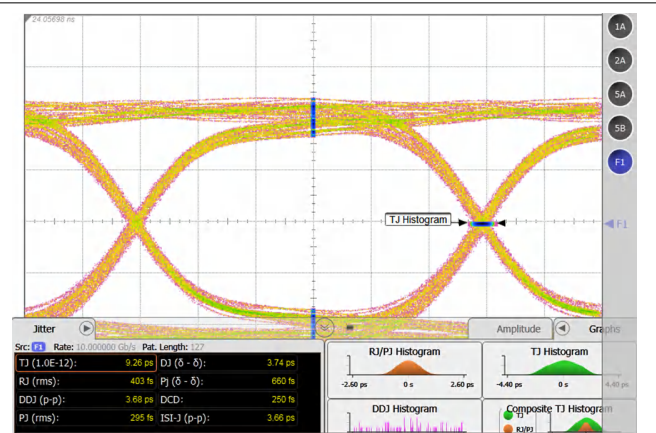

Figure 6-2. Jitter Decomposition of 10 Gbps PRBS-7 Signals Through a Typical TMUXHS4212 Channel in TI Evaluation Board

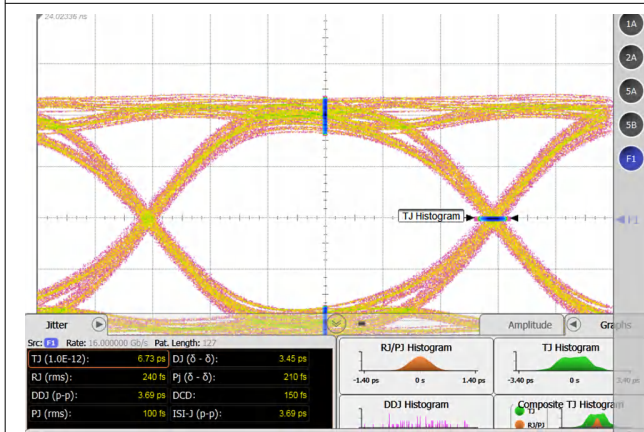

Figure 6-3. Jitter Decomposition of 16 Gbps PRBS-7 Signals Through Calibration Traces in TI Evaluation Board

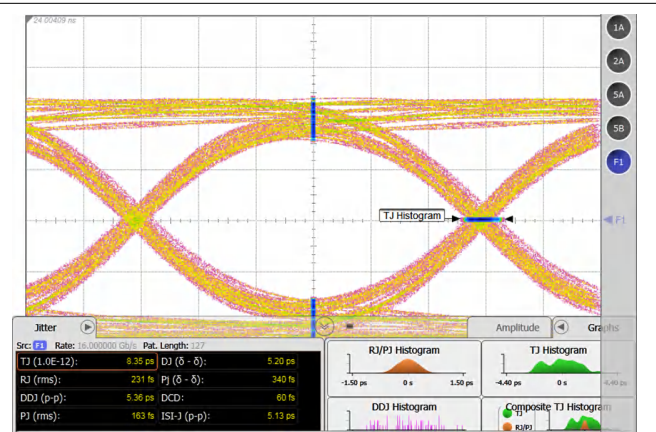

Figure 6-4. Jitter Decomposition of 16 Gbps PRBS-7 Signals Through a Typical TMUXHS4212 Channel in TI Evaluation Board

7 Parameter Measurement Information

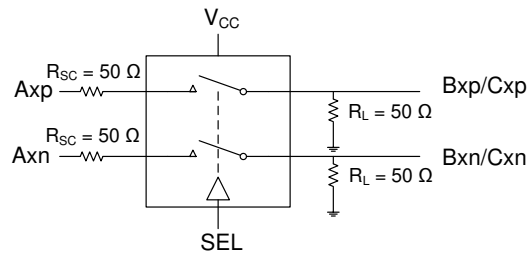

Figure 7-1. Test Setup

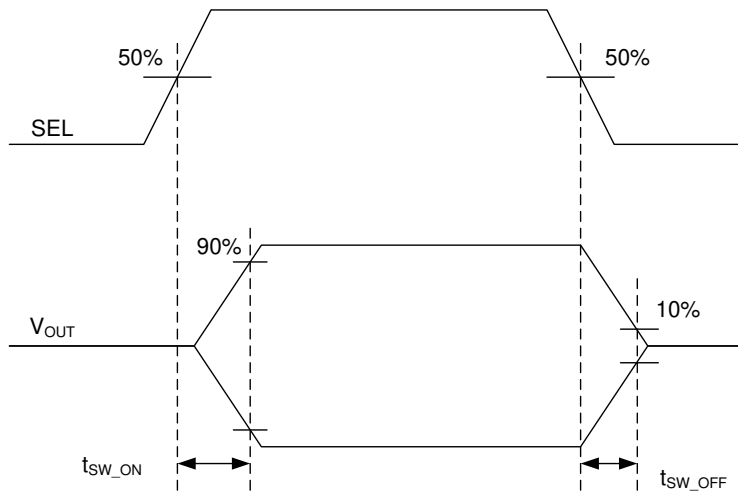

Figure 7-2. Switch On and Off Timing Diagram

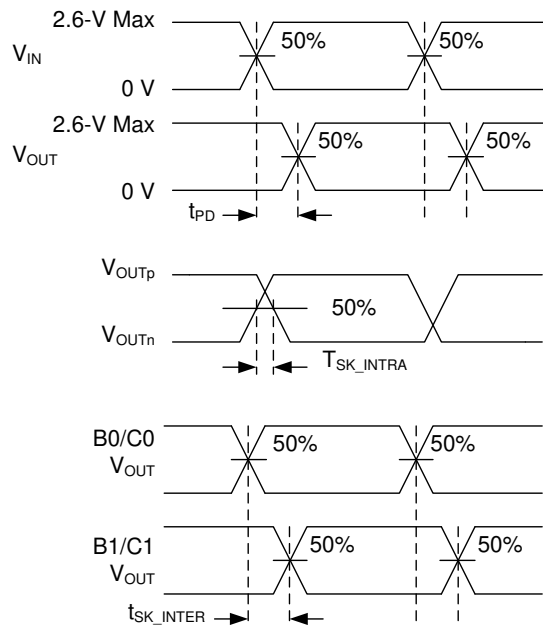

Figure 7-3. Timing Diagrams and Test Setup

8 Detailed Description

8.1 Overview

The TMUXHS4212 is a generic analog differential passive mux or demux that can work for any high-speed interface with differential signaling where common mode voltage (CMV) and differential amplitude up to 1800 mVpp. It employs adaptive input voltage tracking that ensures the channel remains unchanged for the entire common mode voltage range. Two channels of the device can be used for electrical signals that have different CMV between them. Two channels can also be used in such a way that the device switches two different interface signals with different data and electrical characteristics.

Excellent dynamic characteristics of the device allow high speed switching with minimum attenuation to the signal eye diagram with very little added jitter. While the device is recommended for the interfaces up to 16 Gbps, actual data rate where the device can be used highly depends on the electrical channels. For low loss channels where adequate margin is maintained, the device can potentially be used for higher data rates.

The TMUXHS4212 is only recommended for differential signaling. However, certain low voltage single ended signaling (such as, Mipi DPHY LP signaling) can pass through the device. It is recommended to analyze the data line biasing of the device for such single ended use cases.

The TMUXHS4212 comes in two different pinout options that provide layout implementation choices.

8.2 Functional Block Diagram

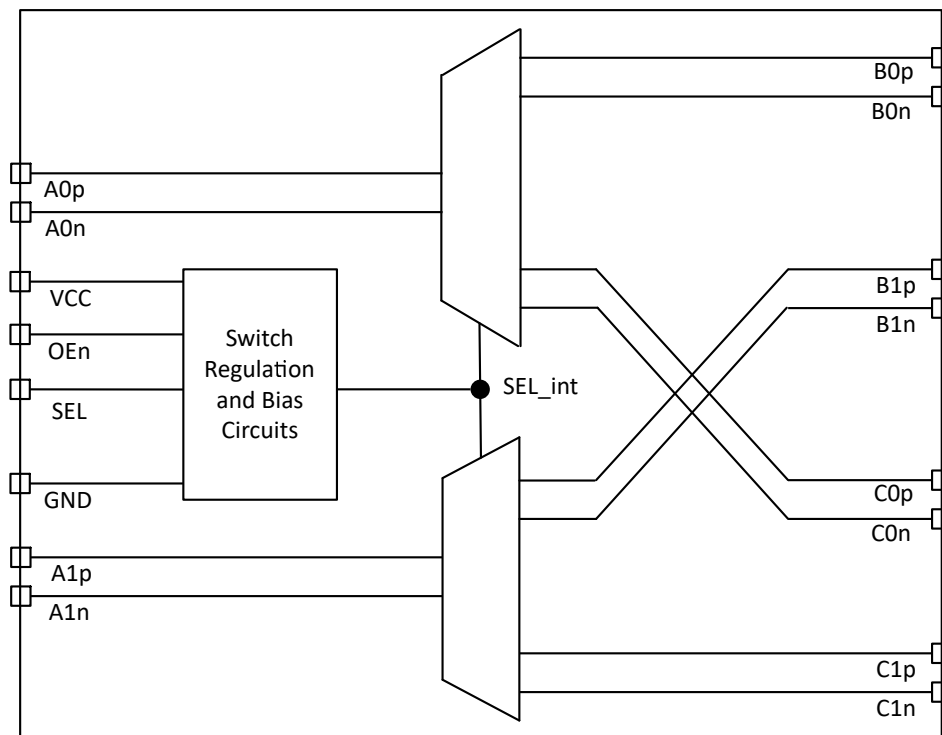

8.3 Feature Description

8.3.1 Output Enable and Power Savings

The TMUXHS4212 has two power modes, active/normal operating mode and standby/shutdown mode. During standby mode, the device consumes very-little current to achieve ultra low power in systems where power saving is critical. To enter standby mode, the OEn control pin is pulled high through a resistor and must remain high. For active/normal operation, the OEn control pin should be pulled low to GND or dynamically controlled to switch between H or L.

The TMUXHS4212 consumes 180 μ A of power when operational and has a shutdown mode exercisable by the OEn pin resulting < 2 μ A.

8.3.2 Data Line Biasing

The TMUXHS4212 has a weak pull-down of 1 M Ω from A[0/1][p/n] pins to GND. While these resistors biases the device data channels to common mode voltage (CMV) of 0 V with very weak strength, it is recommended that the device is biased by a stronger impedance from either side of the device to a valid value in the range of 0 – 1.8 V. To avoid double biasing, ensure that the appropriate ac coupling capacitors are on either side of the device.

In certain use cases, if both sides of the TMUXHS4212 are ac coupled, then it is recommended to use appropriate CMV biasing for the device. 10 k Ω to GND or any other bias voltage in the CMV range for each A[0/1][p/n] pin will suffice for most use cases.

The high-speed data ports incorporate 20 k Ω pull-down resistors that are switched in when a port is not selected and switched out when the port is selected. For example, when SEL = L, the C[0/1][p/n] pins have 20 k Ω resistors to GND. The feature ensures that the unselected port is always biased to a known voltage for long term reliability of the device and the electrical channel.

The positive and negative terminals of data pins A[0/1] have a weak (20 k Ω) differential resistor for device switch regulation operation. This does not impact signal integrity or functionality of high speed differential signaling that typically has much stronger differential impedance (such as 100 Ω).

8.4 Device Functional Modes

Table 8-1. Port Select Control Logic⁽¹⁾

PORT A CHANNEL	PORT B OR PORT C CHANNEL CONNECTED TO PORT A CHANNEL	
	SEL = L	SEL = H
A0p	B0p	C0p
A0n	B0n	C0n
A1p	B1p	C1p
A1n	B1n	C1n

- (1) The TMUXHS4212 can tolerate polarity inversions for all differential signals on Ports A, B, and C. Ensure that the same polarity is maintained on Port A versus Ports B or C in such flexible implementation.

9 Application and Implementation

Note

Information in the following applications sections is not part of the TI component specification, and TI does not warrant its accuracy or completeness. TI's customers are responsible for determining suitability of components for their purposes, as well as validating and testing their design implementation to confirm system functionality.

9.1 Application Information

The TMUXHS4212 is a generic 2-channel high-speed mux or demux type of switch that can be used for routing high-speed signals between two different locations on a circuit board. The TMUXHS4212 supports many high-speed data protocols, provided the signals' differential amplitude and common mode voltage are within <1800 mVpp and a common mode voltage is <1.8 V. The TMUXHS4212 can be used for many high speed interfaces including the following:

- Universal Serial Bus (USB) 3.2 Gen 1.0 and 2.0
- USB Type-C
- Peripheral Component Interconnect Express (PCIe™) Gen 1.0, 2.0, 3.0, and 4.0
- Serial ATA (SATA/eSATA)
- Serial Attached SCSI (SAS)
- DisplayPort (DP) 1.4 and 2.0
- Thunderbolt™ (TBT) 3.0
- Mipi Camera Serial Interface (CSI-2), Display Serial Interface (DSI)
- Low Voltage Differential Signalling (LVDS)
- Serdes Framer Interface (SFI)
- Ethernet Interfaces

The device's mux or demux selection pin SEL can easily be controlled by an available GPIO pin of a controller or hard tie to voltage level H or L as an application requires.

The TMUXHS4212 with adaptive voltage tracking technology can support applications where the common mode is different between the RX and TX pair. The switch paths of the TMUXHS4212 have internal weak pull-down resistors of 1 MΩ on the A port pins. While these resistors bias the device data channels to common mode voltage (CMV) of 0 V with a weak strength, it is recommended that the device is biased from either side of the device to a valid value in the range of 0 – 1.8 V. It is expected that the system/host controller and Device/End point common mode bias impedances are much stronger (smaller) than the TMUXHS4212 internal pull-down resistors; therefore, they are not impacted.

Many interfaces require ac coupling between the transmitter and receiver. The 0201 or 0402 capacitors are the preferred option to provide ac coupling. Avoid the 0603 and 0805 size capacitors and C-packs. When placing ac coupling capacitors, symmetric placement is best. The capacitor value must be chosen according to the specific interface the device is being used. The value of the capacitor should match for the positive and negative signal pair. For many interfaces (such as, USB 3.2 and PCIe) the designer should place them along the TX pairs on the system board, which are usually routed on the top layer of the board. Depending upon the application and interface specifications, use the appropriate value for ac coupling capacitors.

The ac coupling capacitors have several placement options. Typical use cases warrant that the capacitors are placed on one side of the TMUXHS4212. In certain use cases, if both sides of the TMUXHS4212 are ac coupled, then it is recommended to use appropriate CMV biasing for the device. 10 kΩ to GND or any other bias voltage in the range of 0 – 1.8 V for each A[0/1][p/n] pin will suffice for most use cases. [Figure 9-1](#) shows a few placement options. Some interfaces such as USB SS and PCIe recommends ac coupling capacitors on the TX signals before it goes to a connector. Option (a) features TX ac coupling capacitors on the connector side of the TMUXHS4212. Option (b) illustrates the capacitors on the host of the TMUXHS4212. Option (c) showcases where the TMUXHS4212 is ac coupled on both sides. Range for V_{BIAS} is range of 0 – 1.8 V.

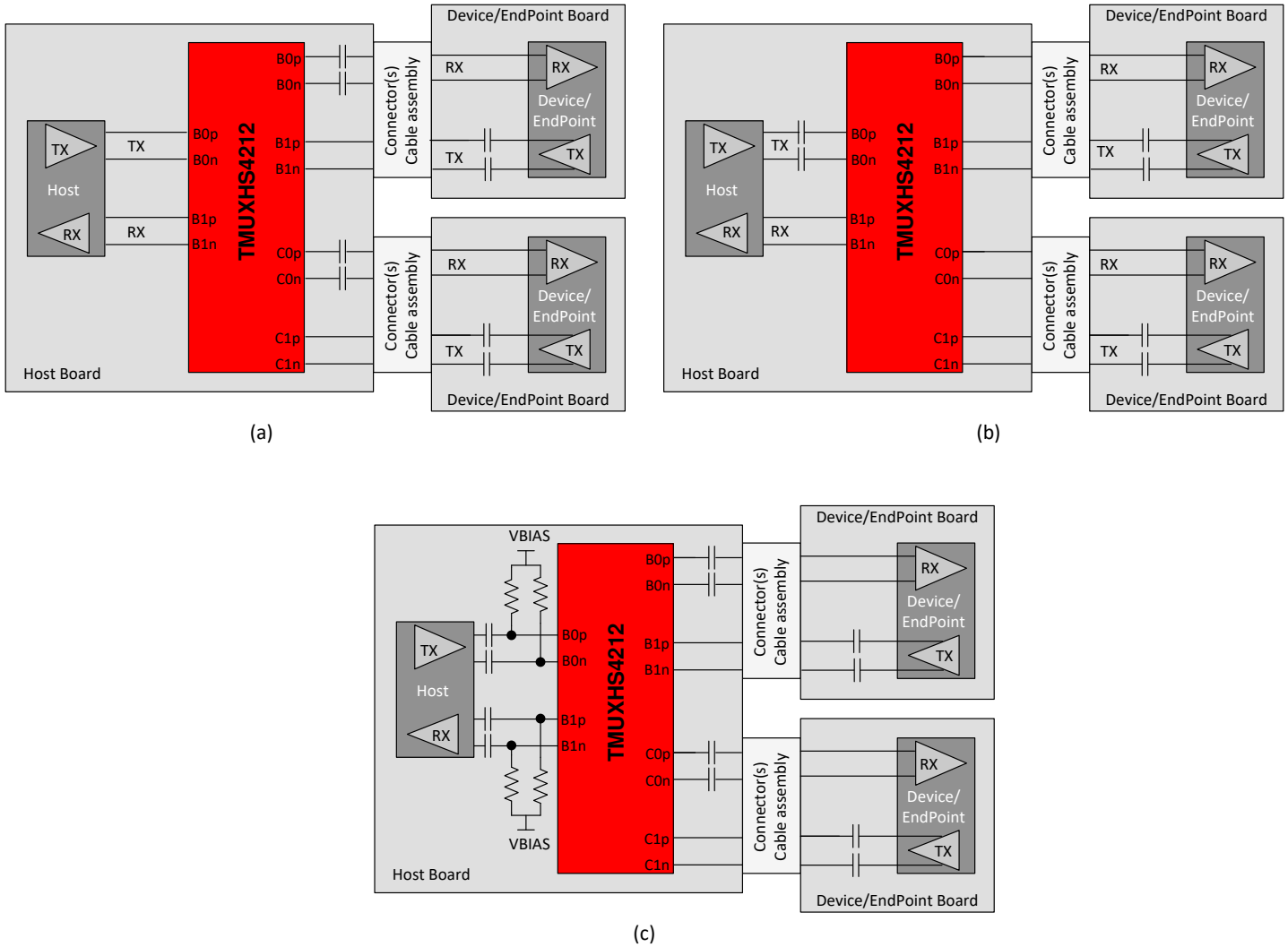

Figure 9-1. AC Coupling Capacitors Placement Options Between Host and Device/Endpoint Through TMUXHS4212

9.2 Typical Applications

9.2.1 USB 3.2 Implementation for USB Type-C

The TMUXHS4212 can be used in USB Type-C implementation to mux USB 3.2 superspeed signals (TX1 and RX1 pairs versus TX2 and RX2 pairs) to accommodate plug flips. In typical use cases, the mux selection is done by a USB Type-C Channel Configuration (CC) or Power Delivery (PD) controller. The device can be used on a USB Type-C DFP, UFP, or DRP port. Figure 9-2 shows two USB Type-C connector applications with both a host and device side. The cable between the two connectors swivels the pairs to properly route the signals to the correct pin. The other applications are more generic because different connectors can be used.

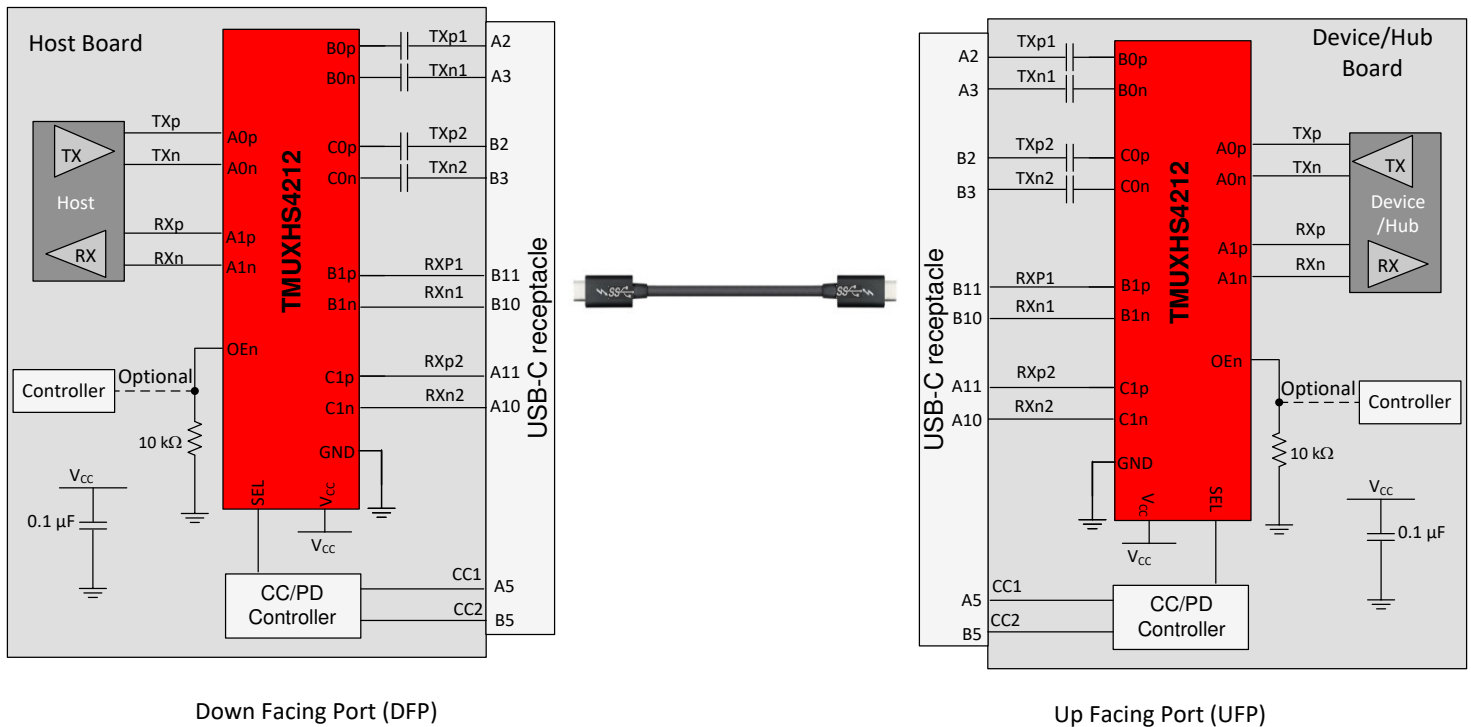

Figure 9-2. USB 3.2 Implementation for USB Type-C Connector

9.2.1.1 Design Requirements

The TMUXHS4212 can be designed into many different applications. All the applications have certain requirements for the system to work properly. The TMUXHS4212 requires 3.3 V \pm 10% V_{CC} rail. The OEn pin must be low for the device to work; otherwise, it disables the outputs. A processor can drive the OEn pin. The expectation is that one side of the device has ac coupling capacitors. Table 9-1 provides information on expected values to perform properly.

Table 9-1. Design Parameters

DESIGN PARAMETER	VALUE
V_{CC}	3.3 V
AXp/n, BXp/n, CXp/n CM input voltage	0 V to 1.8 V
Control/OEn pin max voltage for low	0.5 V
Control/OEn pin min voltage for high	1.42 V
ac coupling capacitor	75 nF to 265 nF
R_{BIAS} (Figure 9-2) when needed	1 k Ω to 100 k Ω

9.2.1.2 Detailed Design Procedure

The TMUXHS4212 is a high-speed passive switch device that can behave as a mux or demux. Because this is a passive switch, signal integrity is important because the device provides no signal conditioning capability. The device can support 2 to 3 inches of board trace and a connector on either end.

To design in the TMUXHS4212, the designer needs to understand the following:

- Determine the loss profile between circuits that are to be muxed or demuxed.
- Provide clean impedance and electrical length matched board traces.
- Provide a control signal for the SEL and OEn pins.
- The thermal pad must be connected to ground.
- See the application schematics on recommended decouple capacitors from V_{CC} pins to ground.

9.2.1.3 Application Curves

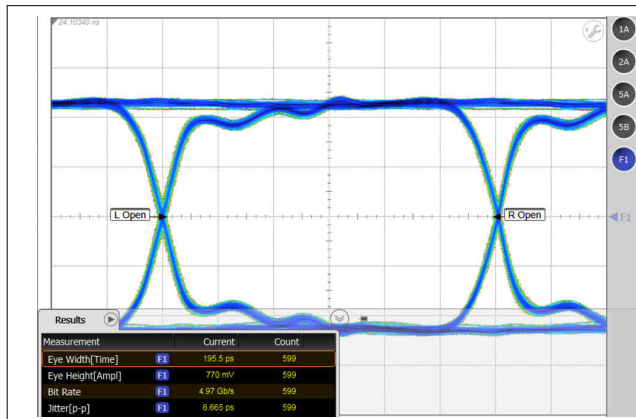

Figure 9-3. 5 Gbps PRBS-7 Signals Through Calibration Traces in TI Evaluation Board

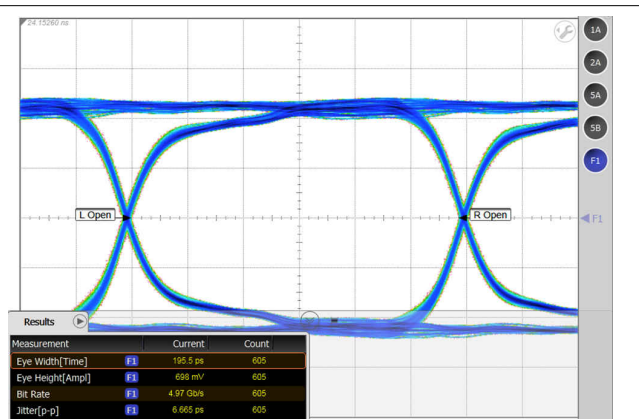

Figure 9-4. 5 Gbps PRBS-7 Signals Through a Typical TMUXHS4212 Channel in TI Evaluation Board

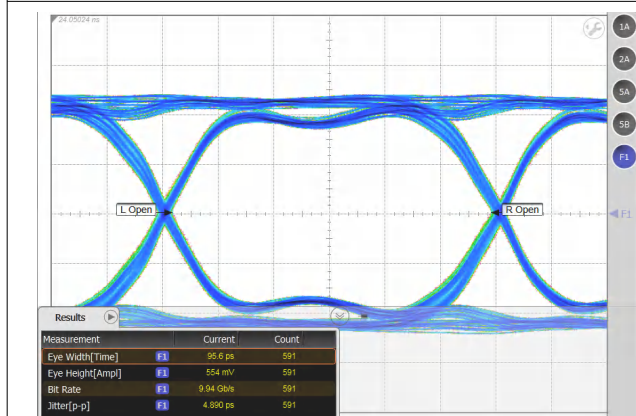

Figure 9-5. 10 Gbps PRBS-7 Signals Through Calibration Traces in TI Evaluation Board

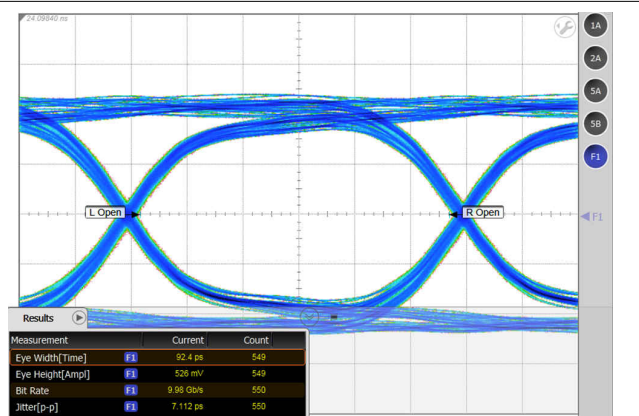

Figure 9-6. 10 Gbps PRBS-7 Signals Through a Typical TMUXHS4212 Channel in TI Evaluation Board

9.2.2 PCIe Lane Muxing

The TMUXHS4212 can be used to switch PCIe lanes between two slots. In many PC and server motherboards, the CPU does not have enough PCIe lanes to provide desired system flexibility for end customers. In such applications, the TMUXHS4212 can be used to switch PCIe TX and RX lanes between two slots. [Figure 9-7](#) provides a schematic where eight TMUXHS4212 devices are used to switch eight PCIe TX and eight RX lanes. Note: the common mode voltage (CMV) bias for the TMUXHS4212 must be within the range of 0 – 1.8 V. In implementations where receiver CMV bias of a PCIe root complex or an end point can not be ensured within the CMV range, additional DC blocking capacitors and appropriate CMV biasing must be implemented.

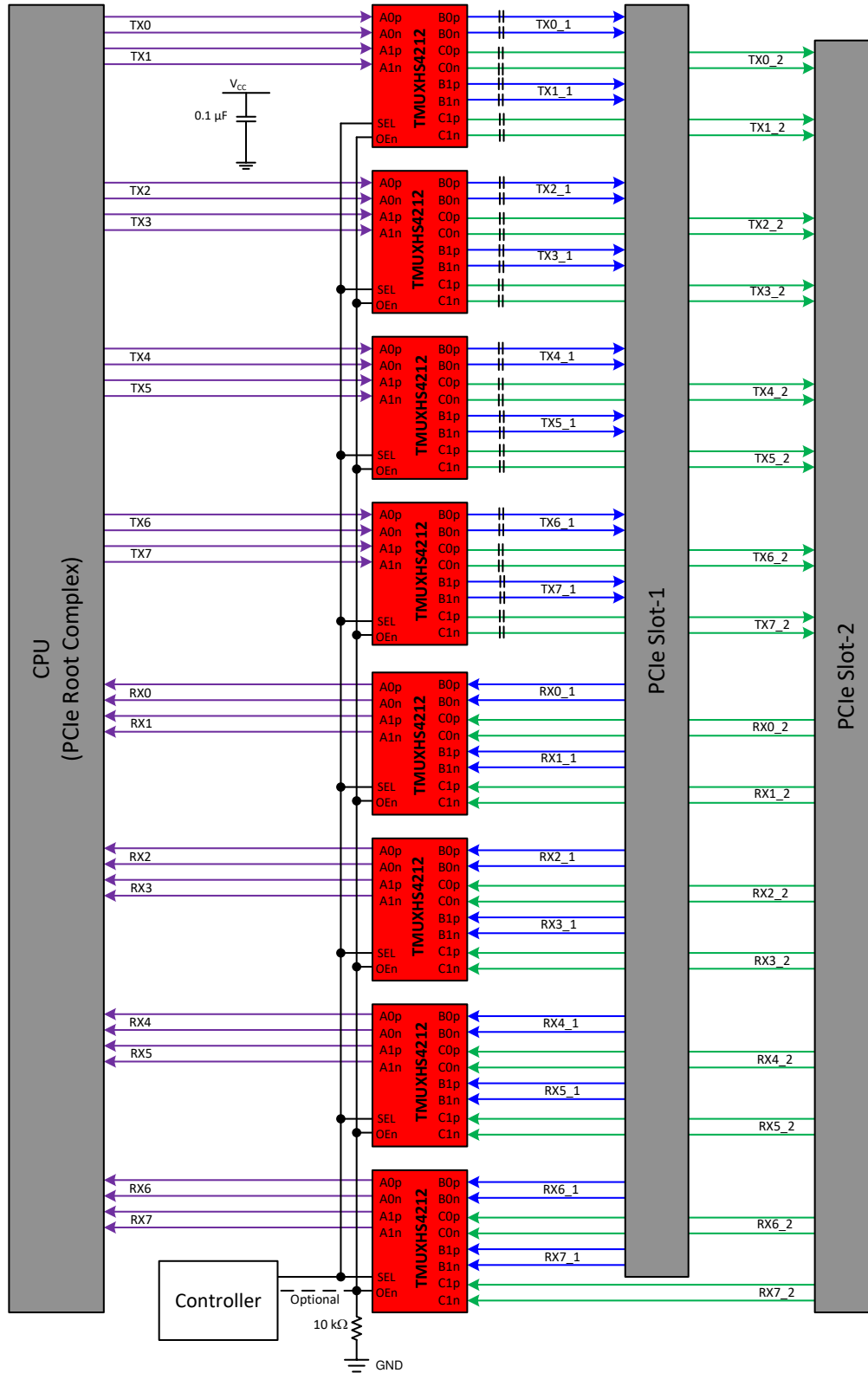

Figure 9-7. PCIe Lane Muxing

9.2.2.1 Application Curves

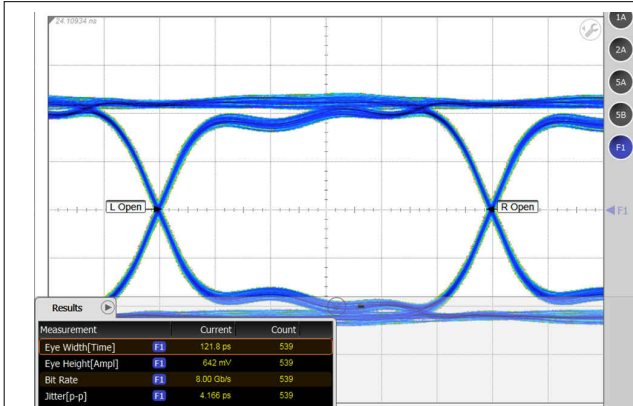

Figure 9-8. 8 Gbps PRBS-7 Signals Through Calibration Traces in TI Evaluation Board

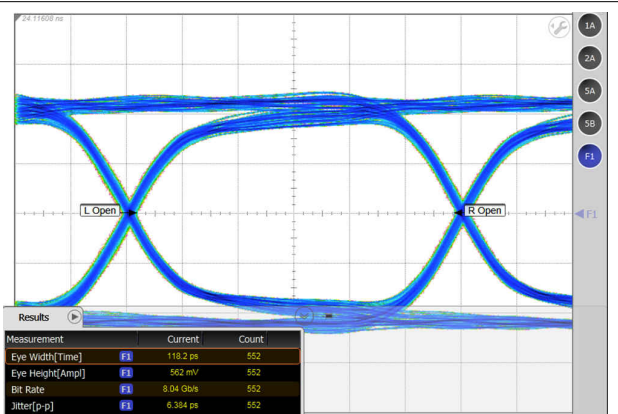

Figure 9-9. 8 Gbps PRBS-7 Signals Through a Typical TMUXHS4212 Channel in TI Evaluation Board

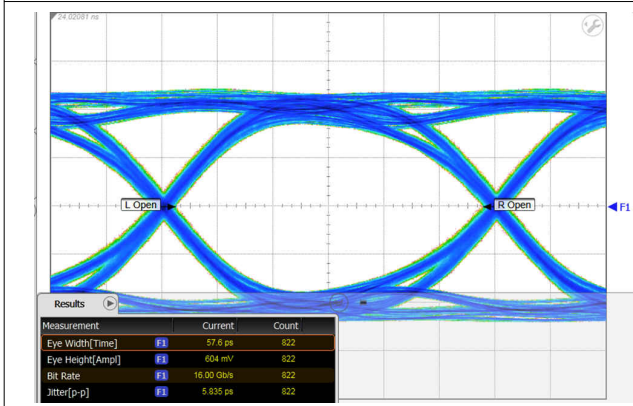

Figure 9-10. 16 Gbps PRBS-7 Signals Through Calibration Traces in TI Evaluation Board

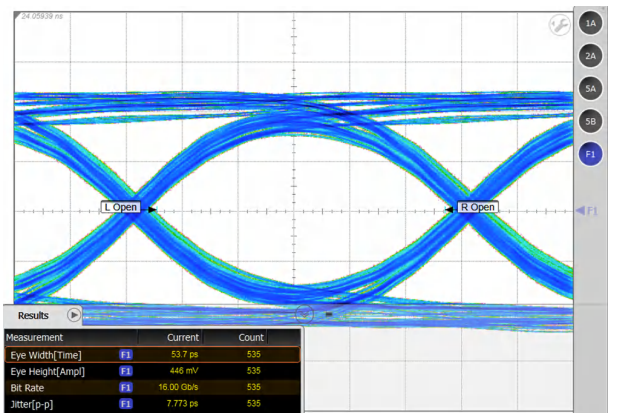

Figure 9-11. 16 Gbps PRBS-7 Signals Through a Typical TMUXHS4212 Channel in TI Evaluation Board

9.3 Systems Examples

9.3.1 USB/eSATA

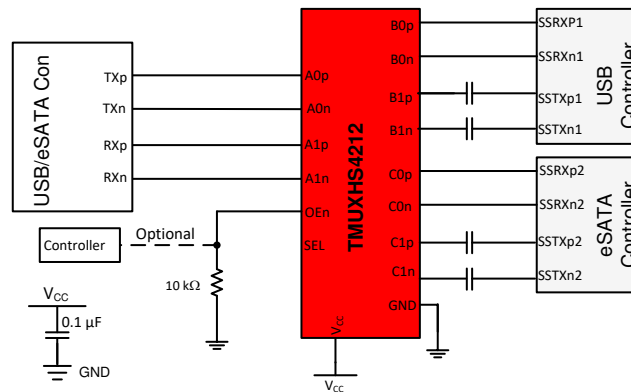

Figure 9-12. eSATA and USB 3.2 Combo Connector

9.3.2 MIPI Camera Serial Interface

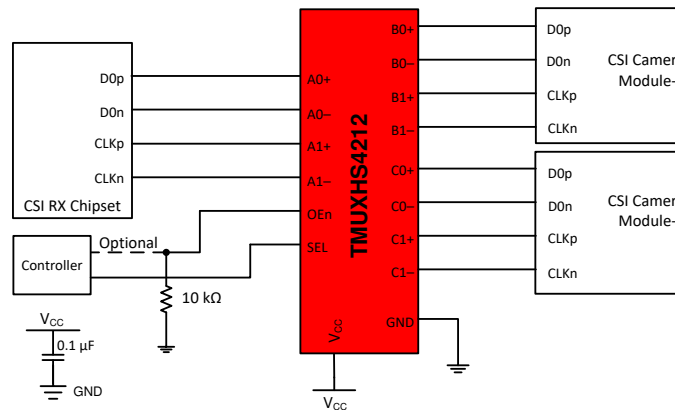

Figure 9-13. CSI Camera Selection

10 Power Supply Recommendations

The TMUXHS4212 does not require a power supply sequence. TI, however, recommends that OEn is asserted low after the device supply V_{CC} is stable and in specification. TI also recommends to place ample decoupling capacitors at the device V_{CC} near the pin.

11 Layout

11.1 Layout Guidelines

On a high-K board, TI always recommends to solder the Power-pad™ onto the thermal land. A thermal land is the area of solder-tinned-copper underneath the Power-pad package. On a high-K board, the TMUXHS4212 can operate over the full temperature range by soldering the Power-pad onto the thermal land without vias.

For high speed layout guidelines, refer to [High-Speed Layout Guidelines for Signal Conditioners and USB Hubs](#).

The designer must use a 1-oz Cu trace connecting the GND pins to the thermal land for the device to operate across the temperature range on a low-K board. A general PCB design guide for Power-pad packages is provided in [Power-pad Thermally-Enhanced Package](#).

11.2 Layout Example

Figure 11-1 shows a basic layout example for the application shown in [Section 9.2.1](#)

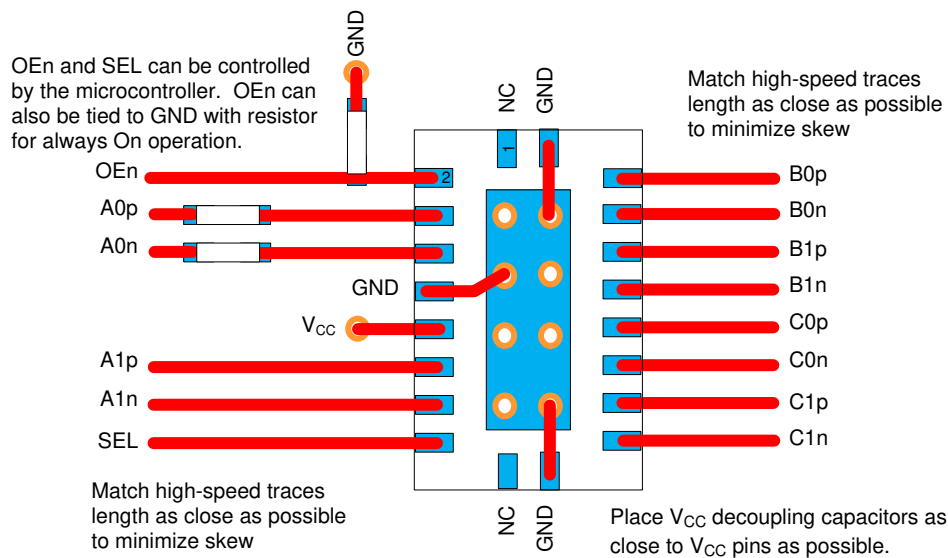

Figure 11-1. TMUXHS4212 Layout Example

12 Device and Documentation Support

12.1 Receiving Notification of Documentation Updates

To receive notification of documentation updates, navigate to the device product folder on ti.com. Click on *Subscribe to updates* to register and receive a weekly digest of any product information that has changed. For change details, review the revision history included in any revised document.

12.2 Support Resources

TI E2E™ [support forums](#) are an engineer's go-to source for fast, verified answers and design help — straight from the experts. Search existing answers or ask your own question to get the quick design help you need.

Linked content is provided "AS IS" by the respective contributors. They do not constitute TI specifications and do not necessarily reflect TI's views; see TI's [Terms of Use](#).

12.3 Trademarks

USB Type-C™ is a trademark of USB Implementation Forum.

PCIe™ is a trademark of PCI-SIG.

Thunderbolt™ is a trademark of Intel Corporation.

Power-pad™ is a trademark of Texas Instruments.

TI E2E™ is a trademark of Texas Instruments.

Mipi® is a registered trademark of MIPI Alliance, Inc..

Ethernet® is a registered trademark of Fuji Xerox Co., Ltd.

All trademarks are the property of their respective owners.

12.4 Electrostatic Discharge Caution



This integrated circuit can be damaged by ESD. Texas Instruments recommends that all integrated circuits be handled with appropriate precautions. Failure to observe proper handling and installation procedures can cause damage.

ESD damage can range from subtle performance degradation to complete device failure. Precision integrated circuits may be more susceptible to damage because very small parametric changes could cause the device not to meet its published specifications.

12.5 Glossary

[TI Glossary](#) This glossary lists and explains terms, acronyms, and definitions.

13 Mechanical, Packaging, and Orderable Information

The following pages include mechanical, packaging, and orderable information. This information is the most current data available for the designated devices. This data is subject to change without notice and revision of this document. For browser-based versions of this data sheet, refer to the left-hand navigation.

PACKAGING INFORMATION

Orderable part number	Status (1)	Material type (2)	Package Pins	Package qty Carrier	RoHS (3)	Lead finish/ Ball material (4)	MSL rating/ Peak reflow (5)	Op temp (°C)	Part marking (6)
TMUXHS4212IRKSR	Active	Production	VQFN (RKS) 20	3000 LARGE T&R	Yes	NIPDAU	Level-1-260C-UNLIM	-40 to 105	HS4212
TMUXHS4212IRKSR.A	Active	Production	VQFN (RKS) 20	3000 LARGE T&R	Yes	NIPDAU	Level-1-260C-UNLIM	-40 to 105	HS4212
TMUXHS4212IRKSRG4	Active	Production	VQFN (RKS) 20	3000 LARGE T&R	Yes	NIPDAU	Level-1-260C-UNLIM	-40 to 105	HS4212
TMUXHS4212IRKSRG4.A	Active	Production	VQFN (RKS) 20	3000 LARGE T&R	Yes	NIPDAU	Level-1-260C-UNLIM	-40 to 105	HS4212
TMUXHS4212IRKST	Active	Production	VQFN (RKS) 20	250 SMALL T&R	Yes	SN	Level-1-260C-UNLIM	-40 to 105	HS4212
TMUXHS4212IRKST.A	Active	Production	VQFN (RKS) 20	250 SMALL T&R	Yes	SN	Level-1-260C-UNLIM	-40 to 105	HS4212
TMUXHS4212RKSR	Active	Production	VQFN (RKS) 20	3000 LARGE T&R	Yes	NIPDAU	Level-1-260C-UNLIM	0 to 70	HS4212
TMUXHS4212RKSR.A	Active	Production	VQFN (RKS) 20	3000 LARGE T&R	Yes	NIPDAU	Level-1-260C-UNLIM	0 to 70	HS4212
TMUXHS4212RKST	Active	Production	VQFN (RKS) 20	250 SMALL T&R	Yes	NIPDAU	Level-1-260C-UNLIM	0 to 70	HS4212
TMUXHS4212RKST.A	Active	Production	VQFN (RKS) 20	250 SMALL T&R	Yes	NIPDAU	Level-1-260C-UNLIM	0 to 70	HS4212

(1) **Status:** For more details on status, see our [product life cycle](#).

(2) **Material type:** When designated, preproduction parts are prototypes/experimental devices, and are not yet approved or released for full production. Testing and final process, including without limitation quality assurance, reliability performance testing, and/or process qualification, may not yet be complete, and this item is subject to further changes or possible discontinuation. If available for ordering, purchases will be subject to an additional waiver at checkout, and are intended for early internal evaluation purposes only. These items are sold without warranties of any kind.

(3) **RoHS values:** Yes, No, RoHS Exempt. See the [TI RoHS Statement](#) for additional information and value definition.

(4) **Lead finish/Ball material:** Parts may have multiple material finish options. Finish options are separated by a vertical ruled line. Lead finish/Ball material values may wrap to two lines if the finish value exceeds the maximum column width.

(5) **MSL rating/Peak reflow:** The moisture sensitivity level ratings and peak solder (reflow) temperatures. In the event that a part has multiple moisture sensitivity ratings, only the lowest level per JEDEC standards is shown. Refer to the shipping label for the actual reflow temperature that will be used to mount the part to the printed circuit board.

(6) **Part marking:** There may be an additional marking, which relates to the logo, the lot trace code information, or the environmental category of the part.

Multiple part markings will be inside parentheses. Only one part marking contained in parentheses and separated by a "~" will appear on a part. If a line is indented then it is a continuation of the previous line and the two combined represent the entire part marking for that device.

Important Information and Disclaimer: The information provided on this page represents TI's knowledge and belief as of the date that it is provided. TI bases its knowledge and belief on information provided by third parties, and makes no representation or warranty as to the accuracy of such information. Efforts are underway to better integrate information from third parties. TI has taken and continues to take reasonable steps to provide representative

and accurate information but may not have conducted destructive testing or chemical analysis on incoming materials and chemicals. TI and TI suppliers consider certain information to be proprietary, and thus CAS numbers and other limited information may not be available for release.

In no event shall TI's liability arising out of such information exceed the total purchase price of the TI part(s) at issue in this document sold by TI to Customer on an annual basis.

TAPE AND REEL INFORMATION

QUADRANT ASSIGNMENTS FOR PIN 1 ORIENTATION IN TAPE

*All dimensions are nominal

Device	Package Type	Package Drawing	Pins	SPQ	Reel Diameter (mm)	Reel Width W1 (mm)	A0 (mm)	B0 (mm)	K0 (mm)	P1 (mm)	W (mm)	Pin1 Quadrant
TMUXHS4212IRKSR	VQFN	RKS	20	3000	180.0	12.4	2.8	4.8	1.2	4.0	12.0	Q1
TMUXHS4212IRKSRG4	VQFN	RKS	20	3000	180.0	12.4	2.8	4.8	1.2	4.0	12.0	Q1
TMUXHS4212IRKST	VQFN	RKS	20	250	180.0	12.4	2.8	4.8	1.2	4.0	12.0	Q1
TMUXHS4212RKSR	VQFN	RKS	20	3000	180.0	12.4	2.8	4.8	1.2	4.0	12.0	Q1
TMUXHS4212RKST	VQFN	RKS	20	250	180.0	12.4	2.8	4.8	1.2	4.0	12.0	Q1

TAPE AND REEL BOX DIMENSIONS

*All dimensions are nominal

Device	Package Type	Package Drawing	Pins	SPQ	Length (mm)	Width (mm)	Height (mm)
TMUXHS4212IRKSR	VQFN	RKS	20	3000	210.0	185.0	35.0
TMUXHS4212IRKSRG4	VQFN	RKS	20	3000	210.0	185.0	35.0
TMUXHS4212IRKST	VQFN	RKS	20	250	210.0	185.0	35.0
TMUXHS4212RKSR	VQFN	RKS	20	3000	210.0	185.0	35.0
TMUXHS4212RKST	VQFN	RKS	20	250	210.0	185.0	35.0

GENERIC PACKAGE VIEW

RKS 20

VQFN - 1 mm max height

2.5 x 4.5, 0.5 mm pitch

PLASTIC QUAD FLATPACK - NO LEAD

This image is a representation of the package family, actual package may vary.
Refer to the product data sheet for package details.



4226872/A

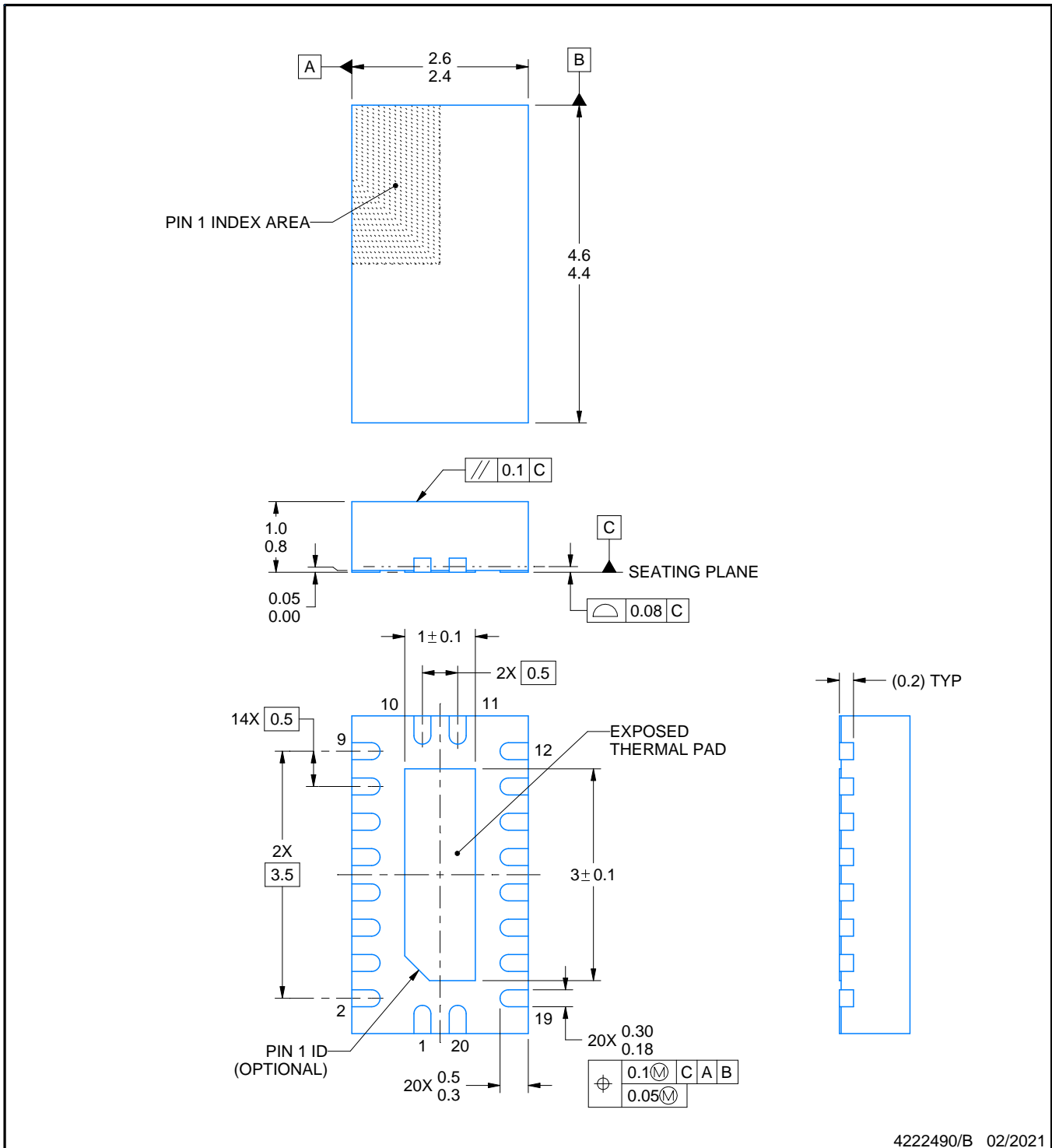

NOTES:

1. All linear dimensions are in millimeters. Any dimensions in parenthesis are for reference only. Dimensioning and tolerancing per ASME Y14.5M.
2. This drawing is subject to change without notice.
3. The package thermal pad must be soldered to the printed circuit board for thermal and mechanical performance.

EXAMPLE BOARD LAYOUT

RKS0020A

VQFN - 1 mm max height

PLASTIC QUAD FLATPACK - NO LEAD

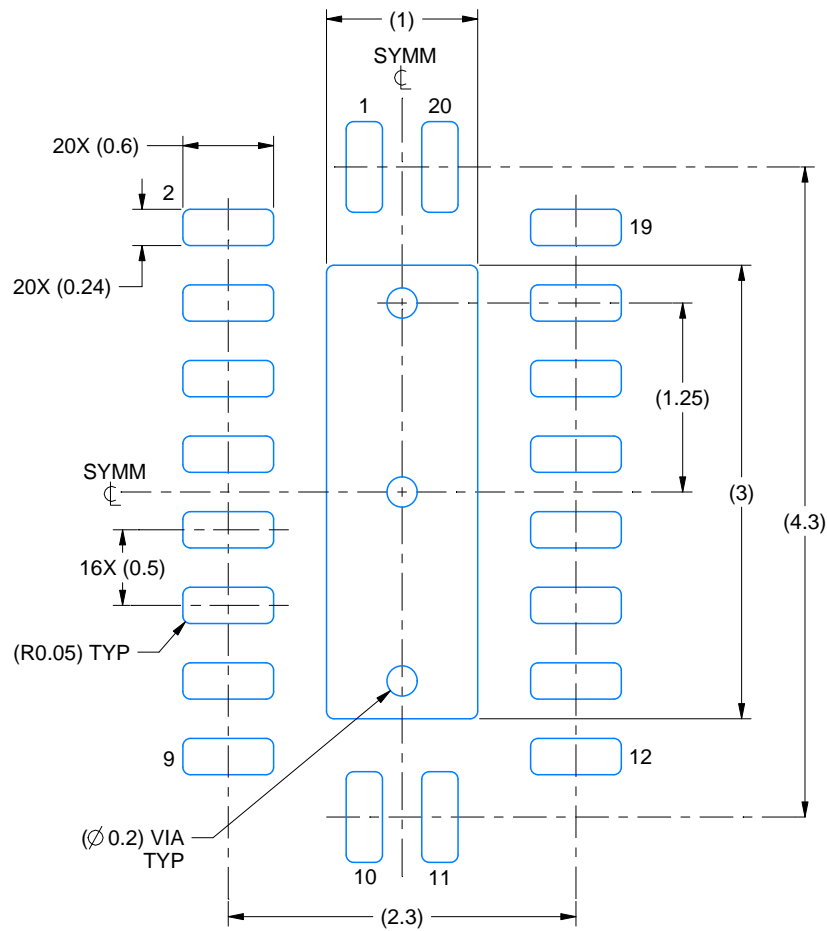

LAND PATTERN EXAMPLE
SCALE:20X



SOLDER MASK DETAILS

4222490/B 02/2021

NOTES: (continued)

- This package is designed to be soldered to a thermal pad on the board. For more information, see Texas Instruments literature number SLUA271 (www.ti.com/lit/slua271).
- Vias are optional depending on application, refer to device data sheet. If some or all are implemented, recommended via locations are shown.

EXAMPLE STENCIL DESIGN

RKS0020A

VQFN - 1 mm max height

PLASTIC QUAD FLATPACK - NO LEAD



SOLDER PASTE EXAMPLE
 BASED ON 0.125 mm THICK STENCIL

EXPOSED PAD
 83% PRINTED SOLDER COVERAGE BY AREA
 SCALE:25X

4222490/B 02/2021

NOTES: (continued)

6. Laser cutting apertures with trapezoidal walls and rounded corners may offer better paste release. IPC-7525 may have alternate design recommendations.

IMPORTANT NOTICE AND DISCLAIMER

TI PROVIDES TECHNICAL AND RELIABILITY DATA (INCLUDING DATASHEETS), DESIGN RESOURCES (INCLUDING REFERENCE DESIGNS), APPLICATION OR OTHER DESIGN ADVICE, WEB TOOLS, SAFETY INFORMATION, AND OTHER RESOURCES "AS IS" AND WITH ALL FAULTS, AND DISCLAIMS ALL WARRANTIES, EXPRESS AND IMPLIED, INCLUDING WITHOUT LIMITATION ANY IMPLIED WARRANTIES OF MERCHANTABILITY, FITNESS FOR A PARTICULAR PURPOSE OR NON-INFRINGEMENT OF THIRD PARTY INTELLECTUAL PROPERTY RIGHTS.

These resources are intended for skilled developers designing with TI products. You are solely responsible for (1) selecting the appropriate TI products for your application, (2) designing, validating and testing your application, and (3) ensuring your application meets applicable standards, and any other safety, security, regulatory or other requirements.

These resources are subject to change without notice. TI grants you permission to use these resources only for development of an application that uses the TI products described in the resource. Other reproduction and display of these resources is prohibited. No license is granted to any other TI intellectual property right or to any third party intellectual property right. TI disclaims responsibility for, and you fully indemnify TI and its representatives against any claims, damages, costs, losses, and liabilities arising out of your use of these resources.

TI's products are provided subject to [TI's Terms of Sale](#), [TI's General Quality Guidelines](#), or other applicable terms available either on ti.com or provided in conjunction with such TI products. TI's provision of these resources does not expand or otherwise alter TI's applicable warranties or warranty disclaimers for TI products. Unless TI explicitly designates a product as custom or customer-specified, TI products are standard, catalog, general purpose devices.

TI objects to and rejects any additional or different terms you may propose.

Copyright © 2026, Texas Instruments Incorporated

Last updated 10/2025