

# TPS1H000-Q1 Automotive 40V, 1Ω, Single-Channel Smart High-Side Switch

## 1 Features

- Qualified for automotive applications
- AEC-Q100 qualified with the following results:
  - Device temperature grade 1: –40°C to 125°C ambient operating temperature range
  - Device HBM ESD Classification Level H2
  - Device CDM ESD Classification Level C4B
- Single-channel 1000mΩ smart high-side switch
- Wide operating voltage: 3.4V to 40V
- Low standby current: <500nA
- Adjustable current limit with external resistor
  - ±15% When ≥150mA
  - ±10% When ≥300mA
- Configurable behavior after current limit
  - Holding mode
  - Latch-off mode with adjustable delay time
  - Auto-retry mode
- Supports standalone operation without an MCU
- Protection:
  - Short-to-GND and overload
  - Thermal shutdown and thermal swing
  - Negative voltage clamp for inductive loads
  - Loss-of-GND and loss-of-battery
- Diagnostics:
  - Overload and short-to-GND detection
  - Open-load and short-to-battery detection in ON or OFF State
  - Thermal shutdown and thermal swing

## 2 Applications

- Single-channel LED driver
- Single-channel high-side relay driver
- Body lighting
- Advanced driver assistance systems (ADAS) sensors
- General resistive, inductive, and capacitive loads

## 3 Description

The TPS1H000-Q1 device is a fully protected single-channel high-side power switch with an integrated 1000mΩ NMOS power FET.

An adjustable current limit improves system reliability by limiting the inrush or overload current. The high accuracy of the current limit improves overload protection, simplifying the front-stage power design. Configurable features besides current limit provide design flexibility in the areas of functionality, cost, and thermal dissipation.

The device supports full diagnostics with the digital status output. Open-load detection is available in both the ON- and OFF-states. The device supports operation with or without an MCU. Standalone mode allows use of the device in isolated systems.

### Package Information

PART NUMBER	PACKAGE <sup>(1)</sup>	PACKAGE SIZE <sup>(2)</sup>
TPS1H000-Q1	DGN (HVSSOP, 8)	3.00mm × 4.90mm

- (1) For all available packages, see the orderable addendum at the end of the datasheet.
- (2) The package size (length × width) is a nominal value and includes pins, where applicable.

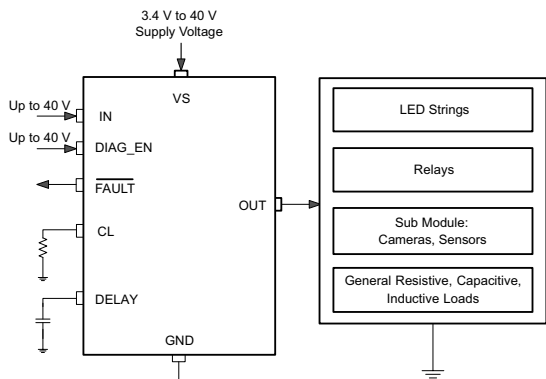

**Typical Block Diagram**

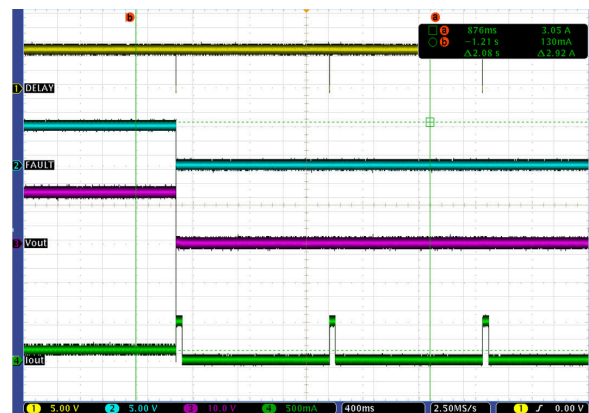

**Current-Limit Protection in Auto-Retry Mode**



## Table of Contents

<b>1 Features</b> .....	1	6.4 Device Functional Modes.....	20
<b>2 Applications</b> .....	1	<b>7 Application and Implementation</b> .....	22
<b>3 Description</b> .....	1	7.1 Application Information.....	22
<b>4 Pin Configuration and Functions</b> .....	3	7.2 Typical Application.....	22
<b>5 Specifications</b> .....	4	7.3 Power Supply Recommendations.....	23
5.1 Absolute Maximum Ratings.....	4	7.4 Layout.....	23
5.2 ESD Ratings.....	4	<b>8 Device and Documentation Support</b> .....	25
5.3 Recommended Operating Conditions.....	4	8.1 Receiving Notification of Documentation Updates.....	25
5.4 Thermal Information.....	5	8.2 Support Resources.....	25
5.5 Electrical Characteristics.....	5	8.3 Trademarks.....	25
5.6 Switching Characteristics.....	7	8.4 Electrostatic Discharge Caution.....	25
5.7 Typical Characteristics.....	8	8.5 Glossary.....	25
<b>6 Detailed Description</b> .....	10	<b>9 Revision History</b> .....	25
6.1 Overview.....	10	<b>10 Mechanical, Packaging, and Orderable Information</b> .....	25
6.2 Functional Block Diagram.....	10		
6.3 Feature Description.....	11		

## 4 Pin Configuration and Functions

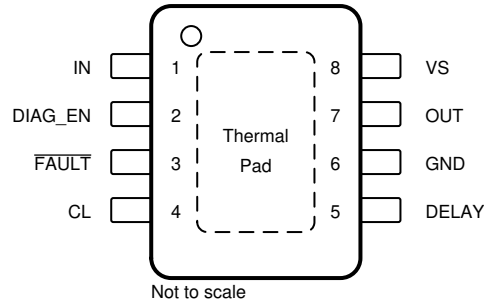

**Figure 4-1. DGN PowerPAD™ Package, 8-Pin HVSSOP With Exposed Thermal Pad (Top View)**

**Table 4-1. Pin Functions**

PIN		TYPE <sup>(1)</sup>	DESCRIPTION
NAME	NO.		
CL	4	O	Adjustable current limit. Connect to device GND if external current limit is not used.
DELAY	5	I/O	Function configuration when in current limit; internal pullup.
DIAG_EN	2	I	Enable the diagnostic function.
FAULT	3	O	Open-drain diagnostic status output. Leave floating if not used.
GND	6	—	Ground pin.
IN	1	I	Input control for output activation; internal pulldown.
OUT	7	O	Output, source of the high-side switch, connected to the load.
VS	8	I	Power supply, drain for the high-side switch.
Thermal pad	—	—	Thermal pad. Connect to device GND or leave floating.

(1) I = input, O = output, I/O = bidirectional

## 5 Specifications

### 5.1 Absolute Maximum Ratings

over operating ambient temperature range (unless otherwise noted)<sup>(1) (2)</sup>

		MIN	MAX	UNIT
Supply voltage VS pin	t < 400ms	—	42	V
Reverse polarity voltage <sup>(3)</sup>	t < 1 minute	–36	—	V
Current on GND	t < 2 minutes	–100	250	mA
Voltage on IN and DIAG_EN pins		–0.3	42	V
Current on IN and DIAG_EN pins		–10	—	mA
Voltage on DELAY pin		–0.3	7	V
Current on DELAY pin		–60	—	mA
Voltage on $\overline{\text{FAULT}}$ pin		–0.3	7	V
Current on $\overline{\text{FAULT}}$ pin		–30	10	mA
Voltage on CL pin		–0.3	7	V
Current on CL pin		—	6	mA
Voltage on OUT pin		—	42	V
Inductive load switch-off energy dissipation single pulse <sup>(4)</sup>		—	40	mJ
Operating junction temperature		–40	150	°C
Storage temperature, T <sub>stg</sub>		–65	150	°C

- (1) Operation outside the *Absolute Maximum Ratings* may cause permanent device damage. *Absolute Maximum Ratings* do not imply functional operation of the device at these or any other conditions beyond those listed under *Recommended Operating Conditions*. If used outside the *Recommended Operating Conditions* but within the *Absolute Maximum Ratings*, the device may not be fully functional, and this may affect device reliability, functionality, performance, and shorten the device lifetime.
- (2) All voltage values are with respect to ground.
- (3) Reverse polarity condition: V<sub>IN</sub> = 0V, reverse current < I<sub>R(2)</sub>, GND pin 1kΩ resistor in parallel with diode.
- (4) Test condition: V<sub>VS</sub> = 13.5V, L = 300mH, T<sub>J</sub> = 150°C. FR4 2s2p board, 2 × 70μm Cu, 2 × 35μm Cu. 600mm<sup>2</sup> thermal pad copper area.

### 5.2 ESD Ratings

			VALUE	UNIT
V <sub>(ESD)</sub>	Electrostatic discharge	Human-body model (HBM), per AEC Q100-002 <sup>(1)</sup>	±2000	V
			±3000	
		Charged-device model (CDM), per AEC Q100-011	±750	

- (1) AEC Q100-002 indicates that HBM stressing shall be in accordance with the ANSI/ESDA/JEDEC JS-001 specification.

### 5.3 Recommended Operating Conditions

over operating ambient temperature range (unless otherwise noted)

		MIN	NOM	MAX	UNIT
V <sub>S</sub>	Operating voltage	4		40	V
	Voltage on IN and DIAG_EN pins	0		40	V
	Voltage on $\overline{\text{FAULT}}$ pin	0		5	V
I <sub>o,nom</sub>	Nominal dc load current	0		1	A
T <sub>J</sub>	Operating junction temperature	–40		150	°C

## 5.4 Thermal Information

THERMAL METRIC <sup>(1)</sup>		TPS1H000-Q1	UNIT
		DGN (HVSSOP)	
		8 PINS	
R <sub>θJA</sub>	Junction-to-ambient thermal resistance	49.7	°C/W
R <sub>θJC(top)</sub>	Junction-to-case (top) thermal resistance	74.0	°C/W
R <sub>θJB</sub>	Junction-to-board thermal resistance	21.4	°C/W
Ψ <sub>JT</sub>	Junction-to-top characterization parameter	3.8	°C/W
Ψ <sub>JB</sub>	Junction-to-board characterization parameter	21.5	°C/W
R <sub>θJC(bot)</sub>	Junction-to-case (bottom) thermal resistance	7.7	°C/W

(1) For more information about traditional and new thermal metrics, see [Semiconductor and IC Package Thermal Metrics](#).

## 5.5 Electrical Characteristics

over operating ambient temperature range (unless otherwise noted)

PARAMETER		TEST CONDITIONS	MIN	TYP	MAX	UNIT
<b>OPERATING VOLTAGE</b>						
V <sub>VS(nom)</sub>	Nominal operating voltage		4		40	V
V <sub>VS(uvr)</sub>	Undervoltage restart	V <sub>VS</sub> rising	3.5	3.7	4	V
V <sub>VS(uvf)</sub>	Undervoltage shutdown	V <sub>VS</sub> falling	3	3.2	3.4	V
V <sub>(uv,hys)</sub>	Undervoltage shutdown, hysteresis			0.5		V
<b>OPERATING CURRENT</b>						
I <sub>(op)</sub>	Nominal operating current	V <sub>VS</sub> = 13.5V, V <sub>IN</sub> = 5V, V <sub>DIAG_EN</sub> = 0V, I <sub>OUT</sub> = 0.1A, I <sub>CL</sub> = 0.5A.			5	mA
I <sub>(off)</sub>	Standby current	V <sub>VS</sub> = 13.5V, V <sub>IN</sub> = V <sub>DIAG_EN</sub> = V <sub>CL</sub> = V <sub>OUT</sub> = 0V, T <sub>J</sub> = 25°C			0.5	μA
		V <sub>VS</sub> = 13.5V, V <sub>IN</sub> = V <sub>DIAG_EN</sub> = V <sub>CL</sub> = V <sub>OUT</sub> = 0V, T <sub>J</sub> = 125°C			3	
I <sub>(off,diag)</sub>	Standby current with diagnostics enabled	V <sub>VS</sub> = 13.5V, V <sub>IN</sub> = 0V, V <sub>DIAG_EN</sub> = 5V			3	mA
t <sub>(off,deg)</sub>	Standby-mode deglitch time <sup>(1)</sup>	IN from high to low, if deglitch time ≥ t <sub>(off,deg)</sub> , the device enters into standby mode.		12.5		ms
I <sub>lkg(out)</sub>	Output leakage current in off-state	V <sub>VS</sub> = 13.5V, V <sub>IN</sub> = V <sub>DIAG_EN</sub> = V <sub>OUT</sub> = 0V			3	μA
<b>POWER STAGE</b>						
r <sub>DS(on)</sub>	On-state resistance	V <sub>VS</sub> ≥ 3.5V, T <sub>J</sub> = 25°C		1000		mΩ
		V <sub>VS</sub> ≥ 3.5V, T <sub>J</sub> = 150°C			2000	
I <sub>CL(int)</sub>	Internal current limit	CL pin connected to GND	1		1.8	A
I <sub>CL(TSD)</sub>	Current-limit value percentage during thermal shutdown			60%		
V <sub>DS(clamp)</sub>	Drain-to-source voltage internally clamped		45		65	V
<b>OUTPUT DIODE CHARACTERISTICS</b>						
V <sub>F</sub>	Drain-to-source diode voltage	I <sub>N</sub> = 0, I <sub>OUT</sub> = -0.15A	0.3	0.7	1	V
I <sub>R(1)</sub>	Continuous reverse current from source to drain during a short-to-battery condition <sup>(1)</sup>	t < 60s, V <sub>IN</sub> = 0V, T <sub>J</sub> = 25°C.			1	A
I <sub>R(2)</sub>	Continuous reverse current from source to drain during a reverse-polarity condition <sup>(1)</sup>	t < 60s, V <sub>IN</sub> = 0V, T <sub>J</sub> = 25°C. GND pin 1kΩ resistor in parallel with diode.			1	A

## 5.5 Electrical Characteristics (continued)

over operating ambient temperature range (unless otherwise noted)

PARAMETER		TEST CONDITIONS	MIN	TYP	MAX	UNIT
<b>LOGIC INPUT (IN, DIAG_EN)</b>						
$V_{IH}$	Logic high-level voltage		2			V
$V_{IL}$	Logic low-level voltage				0.8	V
$R_{pd,in}$	Logic-pin pulldown resistor	IN. $V_{IN} = 5V$	150		400	k $\Omega$
		DIAG_EN. $V_{VS} = V_{DIAG\_EN} = 5V$	350		850	
<b>DIAGNOSTICS</b>						
$I_{kg(loss,GND)}$	Loss of ground output leakage current				100	$\mu A$
$t_{d(ol,on)}$	Open-load deglitch time in on-state	$V_{IN} = 5V$ , $V_{DIAG\_EN} = 5V$ , when $I_{OUT} < I_{(ol,on)}$ , duration longer than $t_{d(ol,on)}$ , open load is detected.	200	300	450	$\mu s$
$I_{(ol,on)}$	Open-load detection threshold in on-state	$V_{IN} = 5V$ , $V_{DIAG\_EN} = 5V$ , when $I_{OUT} < I_{(ol,on)}$ , duration longer than $t_{d(ol,on)}$ , open load is detected.	1	5	8	mA
$V_{(ol,off)}$	Open-load detection threshold in off-state	$V_{IN} = 0V$ , $V_{DIAG\_EN} = 5V$ , when $V_{VS} - V_{OUT} < V_{(ol,off)}$ , duration longer than $t_{d(ol,off)}$ , open load is detected.	1.4		2.6	V
$t_{d(ol,off)}$	Open-load deglitch time in off-state	$V_{IN} = 0V$ , $V_{DIAG\_EN} = 5V$ , when $V_{VS} - V_{OUT} < V_{(ol,off)}$ , duration longer than $t_{d(ol,off)}$ , open load is detected.	200	300	450	$\mu s$
$I_{(ol,off)}$	Off-state output sink current	$V_{IN} = 0V$ , $V_{DIAG\_EN} = 5V$ , $V_{VS} = V_{OUT} = 13.5V$	-70			$\mu A$
$V_{FAULT}$	<b>FAULT</b> low output voltage	$I_{FAULT} = 2mA$			0.2	V
$t_{FAULT}$	<b>FAULT</b> signal holding time <sup>(1)</sup>			8.5		ms
$T_{(SD)}$	Thermal shutdown threshold <sup>(1)</sup>			175		$^{\circ}C$
$T_{(SD,rst)}$	Thermal shutdown status reset <sup>(1)</sup>			155		$^{\circ}C$
$T_{(sw)}$	Thermal swing shutdown threshold <sup>(1)</sup>			60		$^{\circ}C$
$T_{(hys)}$	Hysteresis for resetting the thermal shutdown and swing <sup>(1)</sup>			10		$^{\circ}C$
<b>CURRENT LIMIT AND DELAY CONFIGURATION</b>						
$K_{(CL)}$	Current-limit current ratio <sup>(1)</sup>			600		
$V_{CL(th)}$	Current-limit internal threshold voltage <sup>(1)</sup>			0.8		V
$dK_{(CL)}/K_{(CL)}$	External current limit accuracy <sup>(2)</sup> ( $I_{OUT} - I_{CL} \times K_{(CL)}) \times 100 / (I_{CL} \times K_{(CL)})$ )	$I_{limit} \geq 0.05A$ , $V_{VS} - V_{OUT} \geq 2.5V$	-20%		20%	
		$I_{limit} \geq 0.15A$ , $V_{VS} - V_{OUT} \geq 2.5V$	-15%		15%	
		$I_{limit} \geq 0.3A$ , $I_{limit} < 1A$ , $V_{VS} - V_{OUT} \geq 2.5V$	-10%		10%	
$I_{dl(chg)}$	Delay pin charging current in latch-off mode <sup>(1)</sup>			4.5		$\mu A$
$V_{dl(th)}$	Pulling up threshold in auto-retry mode		2.7			V
$V_{dl(ref)}$	Internal reference voltage in latch-off mode			1.45		V
$t_{dl1}$	Internal fixed delay time <sup>(1)</sup>		300	400	500	$\mu s$
$t_{dl2}$	Adjustable delay time by external capacitor on DELAY pin <sup>(1)</sup>	Connect with 3.3 $\mu F$ capacitor as the maximum value.			1000	ms

## 5.5 Electrical Characteristics (continued)

over operating ambient temperature range (unless otherwise noted)

PARAMETER	TEST CONDITIONS	MIN	TYP	MAX	UNIT
$t_{CL(deg)}$ Deglitch time when current limit <sup>(1)</sup>	IN low to high, $V_{DIAG\_EN} = 5V$ , the deglitch time from IN rising edge to FAULT reporting out.	300		500	$\mu s$
	IN keeps high, $V_{DIAG\_EN} = 5V$ , the deglitch time from CL start-point to FAULT reporting out.	80		180	
$t_{hic(on)}$ On-time when in auto-retry mode <sup>(1)</sup>		35	40	45	ms
$t_{hic(off)}$ Off-time when in auto-retry mode <sup>(1)</sup>		0.8	1	1.2	s

(1) Value specified by design, not subject to production test

(2) External current limit accuracy is only applicable to overload conditions greater than 1.5x the current limit setting

## 5.6 Switching Characteristics

PARAMETER	TEST CONDITIONS	MIN	NOM	MAX	UNIT
$t_{d(on)}$ Turnon delay time, IN rising edge to 10% of $V_{OUT}$	$V_{VS} = 13.5V$ , $V_{DIAG\_EN} = 5V$ , $I_{OUT} = 0.1A$	20	50	90	$\mu s$
$t_{d(off)}$ Turnoff delay time, IN falling edge to 90% of $V_{OUT}$	$V_{VS} = 13.5V$ , $V_{DIAG\_EN} = 5V$ , $I_{OUT} = 0.1A$	20	50	90	$\mu s$
$dV/dt_{(on)}$ Slew rate on, $V_{OUT}$ from 10% to 90%	$V_{VS} = 13.5V$ , $V_{DIAG\_EN} = 5V$ , $I_{OUT} = 0.1A$	0.1		0.6	$V/\mu s$
$dV/dt_{(off)}$ Slew rate off, $V_{OUT}$ from 90% to 10%	$V_{VS} = 13.5V$ , $V_{DIAG\_EN} = 5V$ , $I_{OUT} = 0.1A$	0.3		0.9	$V/\mu s$

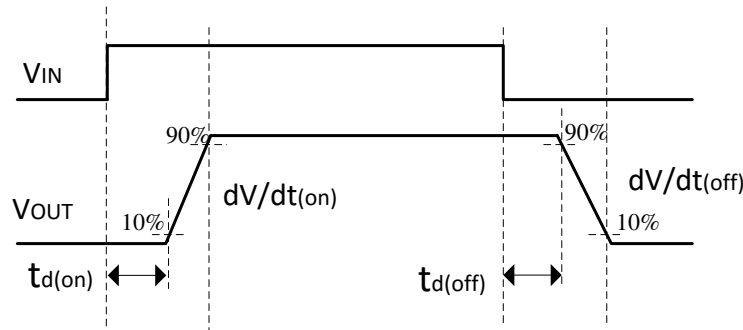

Figure 5-1. Output Delay Characteristics

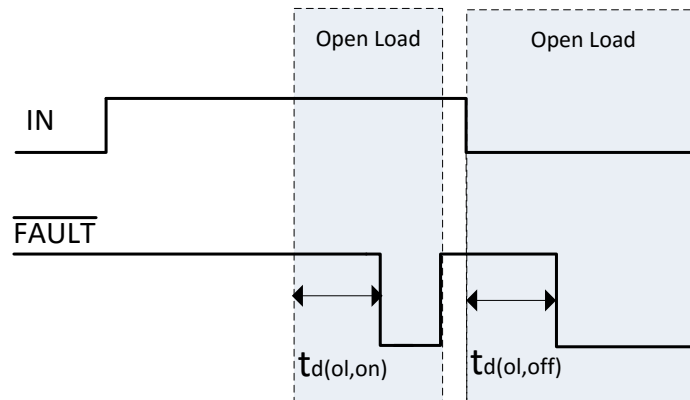

Figure 5-2. Open-Load Blanking-Time Characteristic

## 5.7 Typical Characteristics

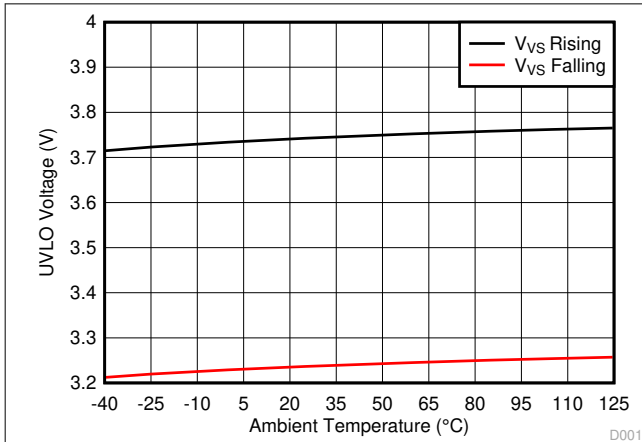

Figure 5-3. UVLO Voltage Threshold

D001

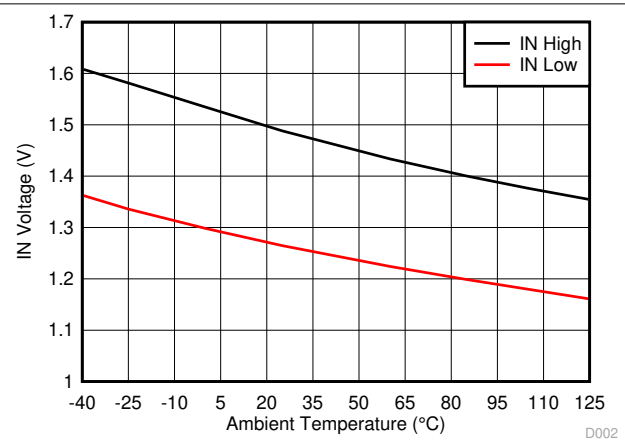

Figure 5-4. IN Voltage Threshold

D002

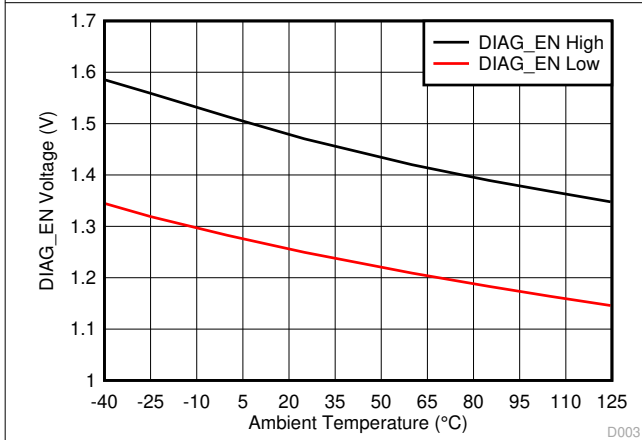

Figure 5-5. DIAG\_EN Voltage Threshold

D003

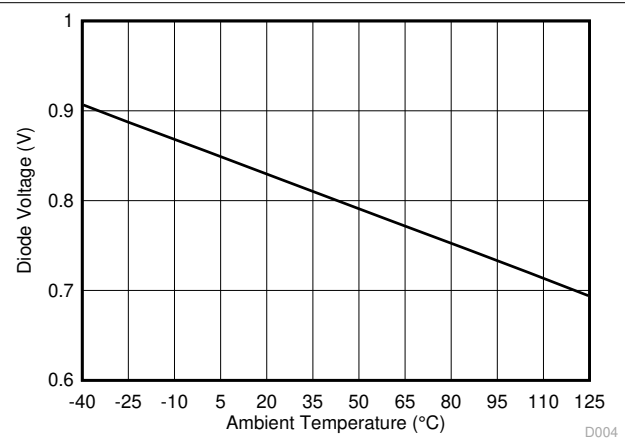

Figure 5-6. Body-Diode Forward Voltage

D004

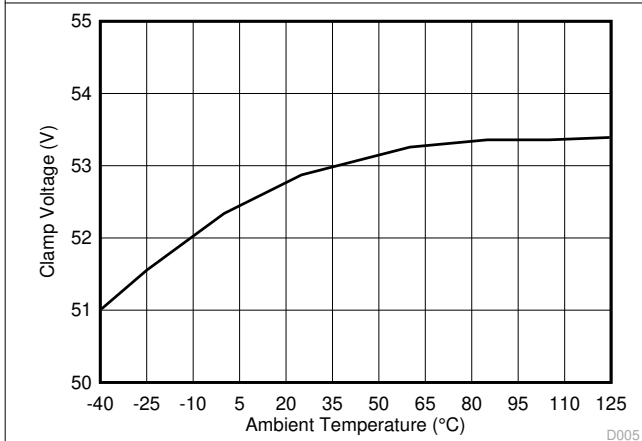

Figure 5-7. Drain-to-Source Clamp Voltage

D005

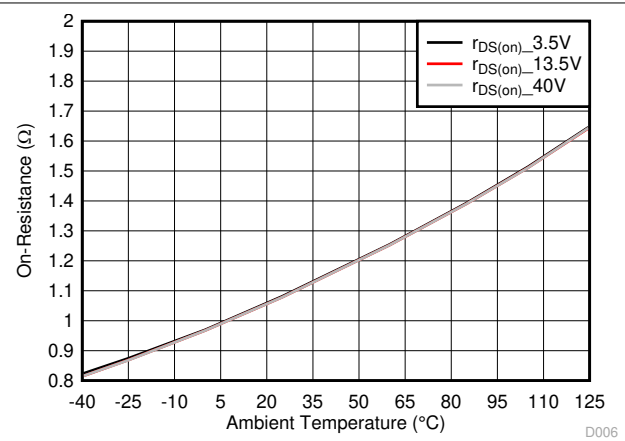
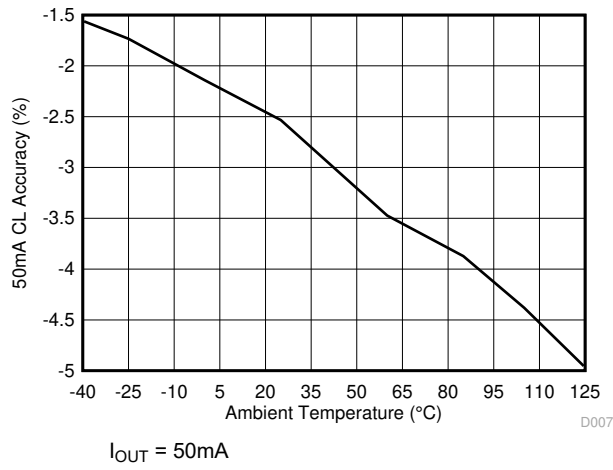

Figure 5-8. FET On-Resistance

D006

### 5.7 Typical Characteristics (continued)



**Figure 5-9. Current-Limit Accuracy at 50mA**

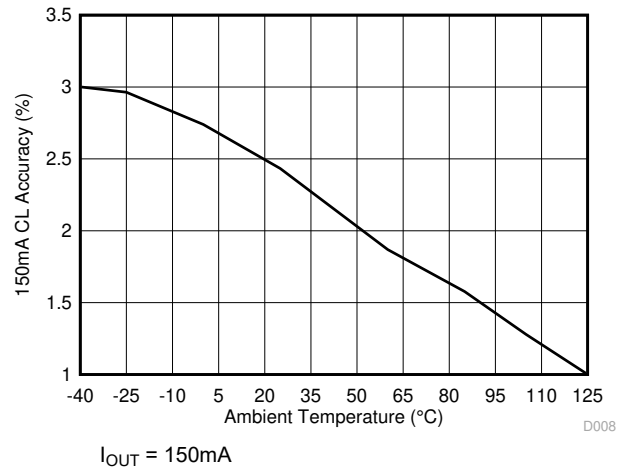

**Figure 5-10. Current-Limit Accuracy at 150mA**

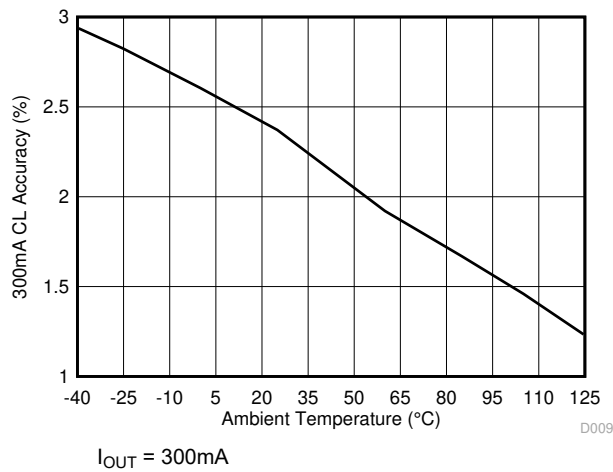

**Figure 5-11. Current-Limit Accuracy at 300mA**

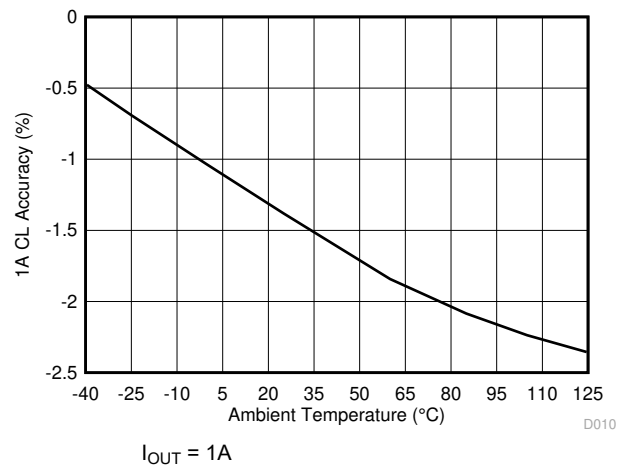

**Figure 5-12. Current-Limit Accuracy at 1A**

## 6 Detailed Description

### 6.1 Overview

The TPS1H000-Q1 device is a smart high-side switch, with an internal charge pump and single-channel integrated NMOS power FET. The adjustable current-limit function greatly improves the reliability of the whole system. Full diagnostic features enable intelligent control of the load.

The external high-accuracy current limit allows setting the current-limit value for the application. When overcurrent occurs, the device improves system reliability by clamping the inrush current effectively. The TPS1H000-Q1 device can also save system cost by reducing the size of PCB traces and connectors, and the capacity of the preceding power stage. The TPS1H000-Q1 device allows three modes when a current limit occurs. Through the configuration on the DELAY pin, users can set the output to any of three modes: hold the current consistently, latch off immediately, or retry automatically. The configurable behaviors during current limit provide design flexibility that considers functionality, cost, and thermal dissipation.

The TPS1H000-Q1 device supports full diagnostics with the digital status output. High-accuracy and low-threshold open-load detection enables real-time on-state monitoring. The TPS1H000-Q1 device also supports operation without an MCU, the standalone mode, which allows the system to implement the full functionality locally.

The TPS1H000-Q1 device is a smart high-side switch for a wide variety of resistive, inductive, and capacitive loads, including LEDs, relays, and sub-modules.

### 6.2 Functional Block Diagram

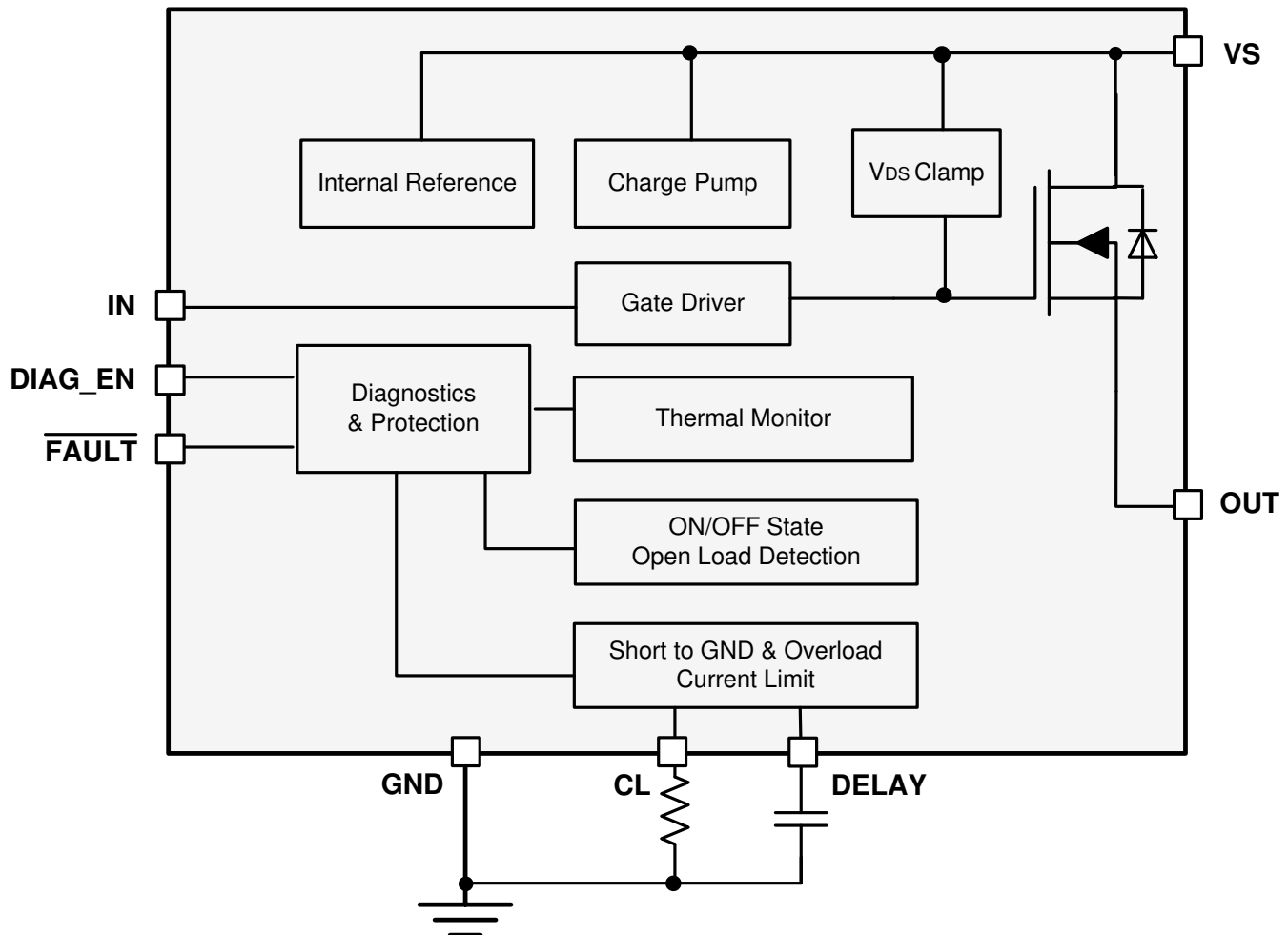

## 6.3 Feature Description

### 6.3.1 Current Limit

A high-accuracy current limit allows high reliability of the design. It protects the load and the power supply from overstressing during short-circuit-to-GND or power-up conditions. The current limit can also save system cost by reducing the size of PCB traces and connectors, and the capacity of the preceding power stage.

When a current-limit threshold is reached, a closed loop activates immediately. The output current is clamped at the set value, and a fault is reported out. The device heats up due to the high power dissipation on the power FET.

The device has two current-limit thresholds.

- Internal current limit – The internal current limit is fixed at  $I_{CL(int)}$ . Tie the CL pin directly to the device GND for large-transient-current applications.
- External adjustable current limit – An external resistor is used to set the current-limit threshold. Use [Equation 1](#) to calculate  $R_{CL}$ .  $V_{CL(th)}$  is the internal band-gap voltage.  $K_{CL}$  is the ratio of the output current and the current-limit set value.  $K_{CL}$  is constant across temperature and supply voltage. The external adjustable current limit allows the flexibility to set the current-limit value by application.

$$R_{CL} = \frac{V_{CL(th)} \times K_{CL}}{I_{OUT}} \quad (1)$$

Note that if using a GND network which causes a level shift between the device GND and board GND, the CL pin must be connected to the device GND.

For better protection from a hard short-to-GND condition (when the IN pin is enabled, a short to GND occurs suddenly), the device implements a fast-trip protection to turn off the output before the current-limit closed loop is set up. The fast-trip response time is less than  $1\mu s$ , typically. With this fast response, the device can achieve better inrush current-suppression performance.

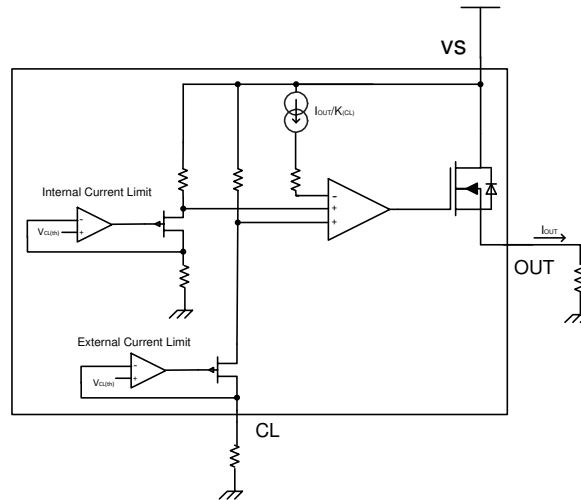

**Figure 6-1. Current Limit**

### 6.3.2 DELAY Pin Configuration

When a current limit occurs, the TPS1H000-Q1 device supports three different behaviors of the output.

**Table 6-1. Current Limit Configurations**

MODE	DELAY CONFIGURATION	OUTPUT CURRENT BEHAVIOR	FAULT RECOVERY
Holding	Connect to GND directly	When hitting a current limit, the output current holds at the setting current. The device enters into thermal shutdown mode when $T_J > T_{(SD)}$ .	$\overline{\text{FAULT}}$ clears when IN turns low for a duration longer than $t_{\text{FAULT}}$ OR when the current limit is removed when IN is high.
Latch-off	Connect to GND through a capacitor	When hitting a current limit, the output current holds at the setting current, but latches off after a preset DELAY time ( $t_{\text{dl1}} + t_{\text{dl2}}$ ). $t_{\text{dl1}}$ is the default delay time; $t_{\text{dl2}}$ is a capacitor-configurable delay time. The output stays latched off regardless of whether the current limit is removed. The output recovers only when IN is toggling.	$\overline{\text{FAULT}}$ clears when IN turns low for a duration longer than $t_{\text{FAULT}}$ .
Auto-retry	External pullup	When hitting a current limit, the output current holds at the setting current, but periodically comes on for $t_{\text{hic(on)}}$ and turns off for $t_{\text{hic(off)}}$ .	$\overline{\text{FAULT}}$ clears when IN turns low for a duration longer than $t_{\text{FAULT}}$ OR when the current limit is removed for $t_{\text{hic(on)}}$

### 6.3.2.1 Holding Mode

Holding mode is active when the DELAY pin connects to GND directly. When hitting a current limit, the output current holds at the setting current. The device enters into thermal shutdown mode when  $T_J > T_{(SD)}$ .

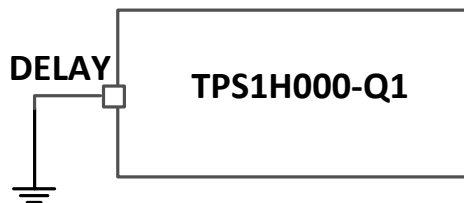
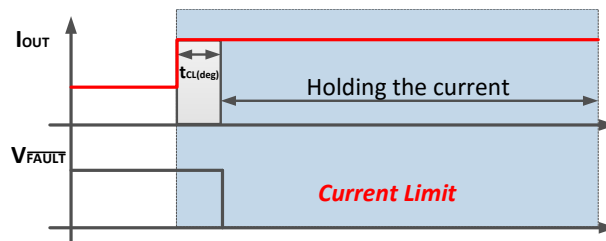
**Figure 6-2. Holding Mode Connection****Figure 6-3. Holding Mode Example**

### 6.3.2.2 Latch-Off Mode

Latch-off mode is active when the DELAY pin connects to GND through a capacitor. When hitting a current limit, the output current holds at the setting current, but latches off after a preset DELAY time ( $t_{\text{dl1}} + t_{\text{dl2}}$ ).  $t_{\text{dl1}}$  is the default delay time,  $t_{\text{dl2}}$  is a configurable delay time set by a capacitor. The output stays latched off regardless of whether the current limit is removed. The output recovers only when IN is toggling.

Use Equation 2 to calculate  $t_{\text{dl2}}$ . The  $I_{\text{dl(chg)}}$  is the device charging current in latch-off mode,  $V_{\text{dl(ref)}}$  is the internal reference voltage in latch off mode,  $t_{\text{dl2}}$  is the user-setting delay time, and  $C_{\text{DELAY}}$  is the capacitor connected on the DELAY pin.

$$C_{\text{DELAY}} = \frac{I_{\text{dl(chg)}} \times t_{\text{dl2}}}{V_{\text{dl(ref)}}} \quad (2)$$

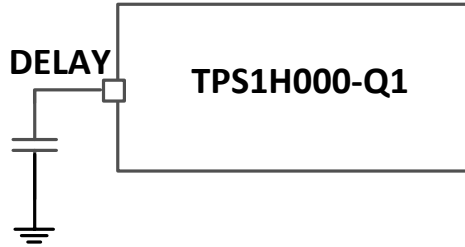

**Figure 6-4. Latch-Off-Mode Connection**

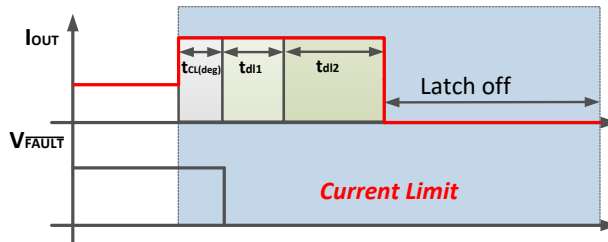

**Figure 6-5. Latch-Off-Mode Example**

### 6.3.2.3 Auto-Retry Mode

Auto-retry mode is active when the DELAY pin is externally pulled up. The pullup voltage must be higher than  $V_{dl(th)}$ . When hitting the current limit, the output current holds at the setting current, but periodically comes on for  $t_{hic(on)}$  and turns off for  $t_{hic(off)}$ .

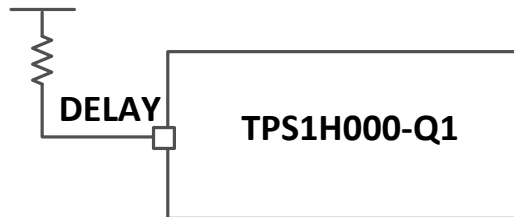

**Figure 6-6. Auto-Retry-Mode Connection**

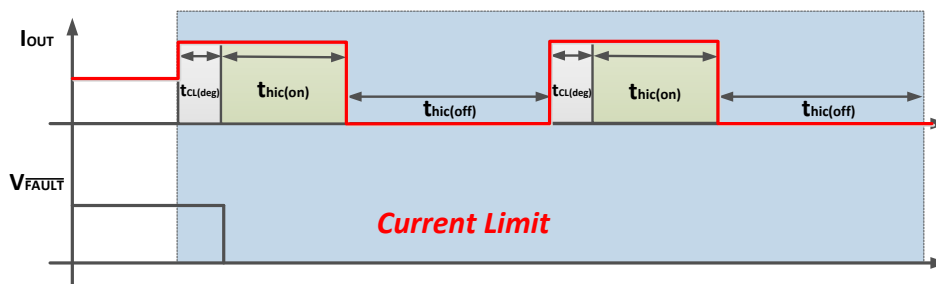

**Figure 6-7. Auto-Retry-Mode Example**

### 6.3.3 Standalone Operation

In a typical application, the TPS1H000-Q1 device is controlled by a microcontroller. The device also supports standalone operation. IN and DIAG\_EN have a 40V maximum dc rating, and can connect to the VS pin directly. In auto-retry mode, the DELAY pin can also connect to the VS pin through a 100kΩ resistor.

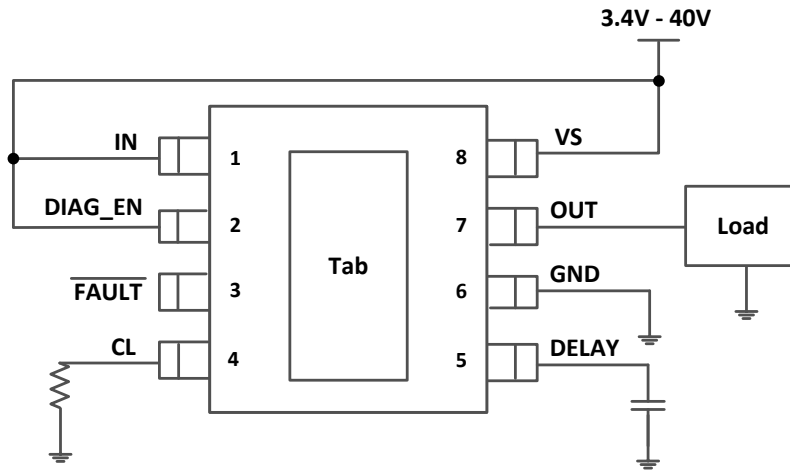

Figure 6-8. Standalone Operation in Latch-Off Mode

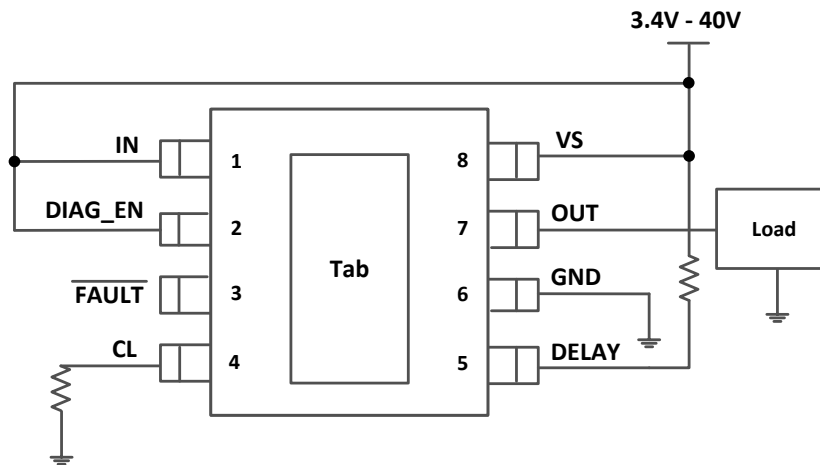

Figure 6-9. Standalone Operation in Auto-Retry Mode

### 6.3.4 Fault Truth Table

The DIAG\_EN pin enables or disables the diagnostic functions. If multiple devices are used, but the ADC resource is limited in the microcontroller, the microcontroller can use GPIOs to set DIAG\_EN high to enable the diagnostics of one device while disabling the diagnostics of the other devices by setting DIAG\_EN low. In addition, the device can keep the power consumption to a minimum by setting DIAG\_EN and IN low.

Table 6-2 applies when the DIAG\_EN pin is enabled. Table 6-3 applies when the DIAG\_EN pin is disabled.

**Table 6-2. Fault Truth Table**

CONDITION	IN	OUT	CRITERION	FAULT	FAULT RECOVERY
Normal	L	L	—	H	—
	H	H	—	H	
Overload or short to GND	H	L	Current limit triggered.	L	See <a href="#">Table 6-1</a> .
Open load or short to battery	H	H	$I_{OUT} < I_{(ol,on)}$	L	$\overline{FAULT}$ clears when IN turns low for a duration longer than $t_{FAULT}$ . OR $\overline{FAULT}$ clears when the open load is removed.
	L <sup>(1)</sup>	H	$V_{VS} - V_{OUT} < V_{(ol,off)}$	L	$\overline{FAULT}$ clears when IN is toggling OR $\overline{FAULT}$ clears when the open load is removed.
Thermal shutdown	H	—	Thermal shutdown triggered	L	$\overline{FAULT}$ clears when IN turns low for a duration longer than $t_{FAULT}$ . OR $\overline{FAULT}$ clears when thermal shutdown quits.
Thermal swing	H	—	Thermal swing triggered	L	$\overline{FAULT}$ clears when IN turns low for a duration longer than $t_{FAULT}$ . OR $\overline{FAULT}$ clears when thermal swing quits.

(1) An external pullup is required for open-load detection.

**Table 6-3. DIAG\_EN Disabled Condition**

DIAG_EN	IN	PROTECTIONS AND DIAGNOSTICS
LOW	ON	Diagnostics disabled, full protections
	OFF	Diagnostics disabled, no protection

### 6.3.5 Full Diagnostics

#### 6.3.5.1 Short-to-GND and Overload Detection

When the output is on, a short to GND or an overload condition causes overcurrent. If the overcurrent triggers either the internal or external current-limit threshold, a fault condition is reported out as  $\overline{FAULT}$  pin = low.

#### 6.3.5.2 Open-Load Detection

##### 6.3.5.2.1 Output On

When the output is on, if the current flowing through the output  $I_{OUT} < I_{(ol,on)}$ , the device recognizes an open-load fault. For open-load detection in output on, no external circuitry is required.

##### 6.3.5.2.2 Output Off

When the output is off, if a load is connected, the output is pulled down to GND. But if an open load occurs, the output voltage is close to the supply voltage ( $V_{VS} - V_{OUT} < V_{(ol,off)}$ ), and the device recognizes an open-load fault.

There is always a leakage current  $I_{(ol,off)}$  present on the output due to the internal logic control path or external humidity, corrosion, and so forth. So an external pullup resistor is recommended to offset the leakage current when an open load is detected. The recommended pullup resistance is 15k $\Omega$ .

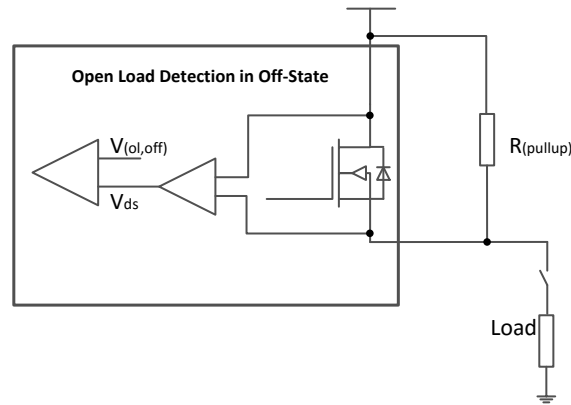

Figure 6-10. Open-Load Detection in Output Off

**6.3.5.3 Short-to-Battery Detection**

Short-to-battery has the same detection mechanism and behavior as open-load detection, in both the on-state and off-state.

**6.3.5.4 Thermal Fault Detection**

To protect the device in severe power stressing cases, the device implements two types of thermal fault detection, absolute temperature protection (thermal shutdown) and dynamic temperature protection (thermal swing).

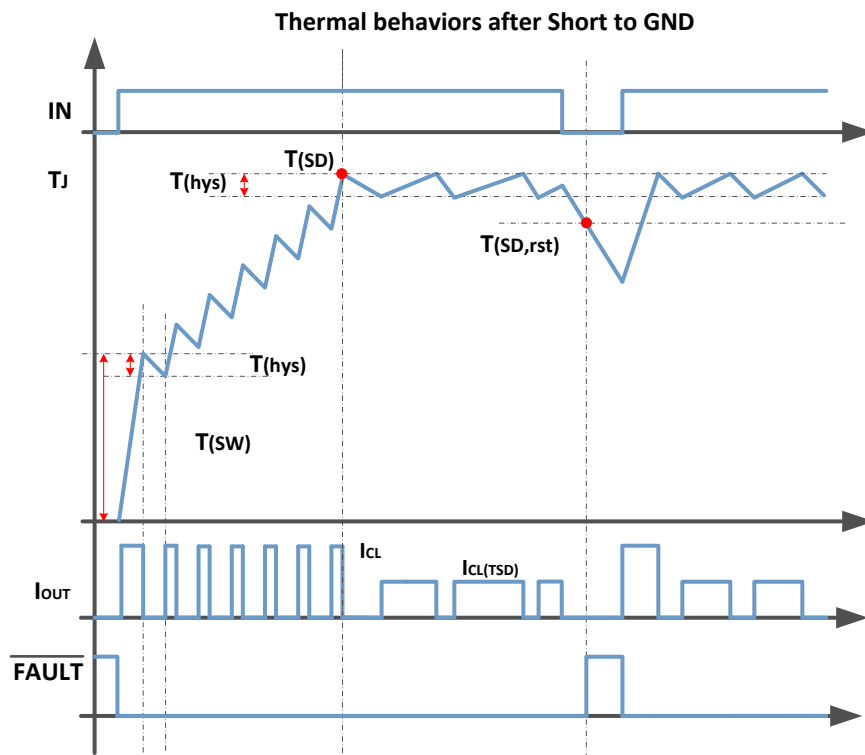

Figure 6-11. Thermal Behavior Diagram

**6.3.5.4.1 Thermal Shutdown**

Thermal shutdown is active when the absolute temperature  $T_J > T_{(SD)}$ . When thermal shutdown occurs, the output turns off.

### 6.3.5.4.2 Thermal Swing

Thermal swing activates when the power FET temperature is increasing sharply, that is, when Equation 3, then the output turns off.

$$\Delta T = T_{(FET)} - T_{(Logic)} > T_{(sw)} \quad (3)$$

The output automatically recovers and the fault signal clears when

$$\Delta T = T_{(FET)} - T_{(Logic)} < T_{(sw)} - T_{(hys)} \quad (4)$$

The thermal swing function improves the device reliability when subjected to repetitive fast thermal variation.

### 6.3.5.4.3 Fault Report Holding

When using PWM dimming,  $\overline{FAULT}$  is easily cleared by the PWM falling edge. Even if the fault condition remains all the time,  $\overline{FAULT}$  is discontinuous. To avoid this unexpected fault report behavior, the device implements fault-report holding time. Figure 6-12 shows a typical issue when PWM dimming, the  $\overline{FAULT}$  is cleared unexpectedly even when the short-to-GND still exists. The TPS1H000-Q1 device with fault-report holding function allows the right behavior as shown in Figure 6-13.

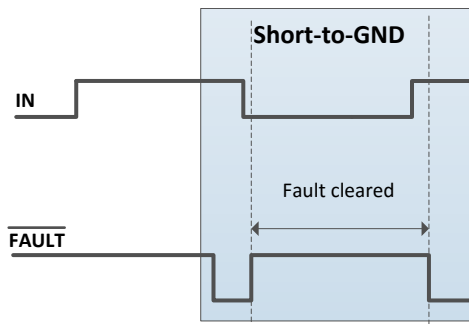

**Figure 6-12. Without Fault-Report Holding**

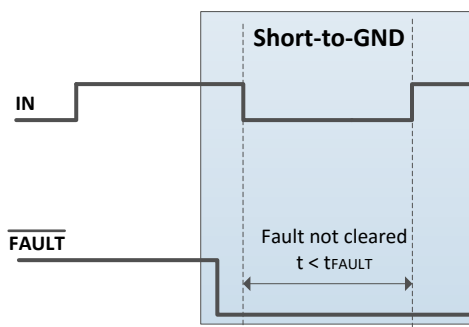

**Figure 6-13. With Fault-Report Holding**

## 6.3.6 Full Protections

### 6.3.6.1 UVLO Protection

The device monitors the supply voltage,  $V_{VS}$ , to prevent unpredicted behaviors when  $V_{VS}$  is too low. When  $V_{VS}$  falls down to  $V_{VS(uvf)}$ , the device shuts down. When  $V_{VS}$  rises up to  $V_{VS(uvr)}$ , the device turns on.

### 6.3.6.2 Inductive Load Switching Off Clamp

When switching an inductive load off, the inductive reactance tends to pull the output voltage negative. Excessive negative voltage can cause the power FET to break down. To protect the power FET, an internal clamp between drain and source is implemented, namely  $V_{DS(clamp)}$ .

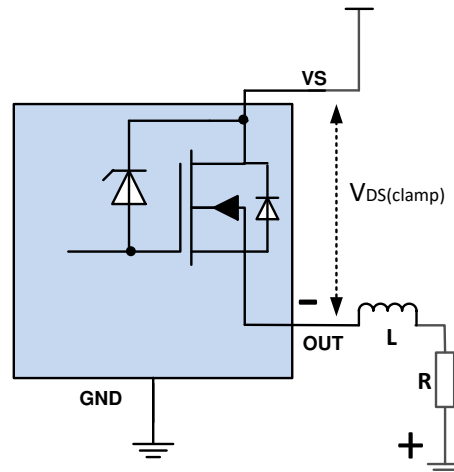

**Figure 6-14. Drain-to-Source Clamping Structure**

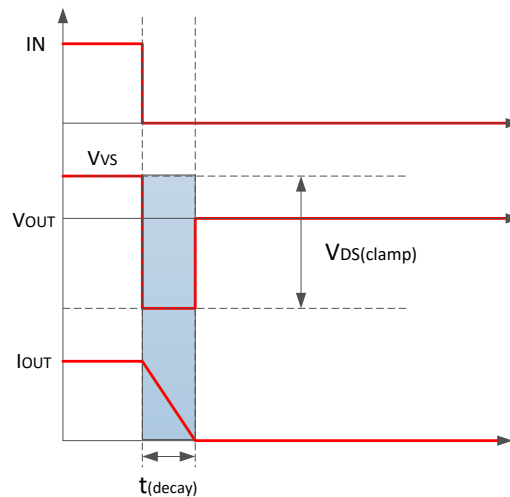

**Figure 6-15. Inductive-Load Switching-Off Diagram**

**6.3.6.3 Loss-of-GND Protection**

When loss of GND occurs, the output is shut down regardless of whether the IN pin is high or low. The device can protect against two ground-loss conditions, loss of device GND and loss of module GND.

**6.3.6.4 Loss-of-Power-Supply Protection**

When loss of supply occurs, the output is shut down regardless of whether the IN pin is high or low. For a resistive or a capacitive load, loss of supply has no risk. But for a charged inductive load, the current is driven from all the logic control pins to maintain the inductance current. To protect the system in this condition, TI recommends protection with an external free-wheeling diode.

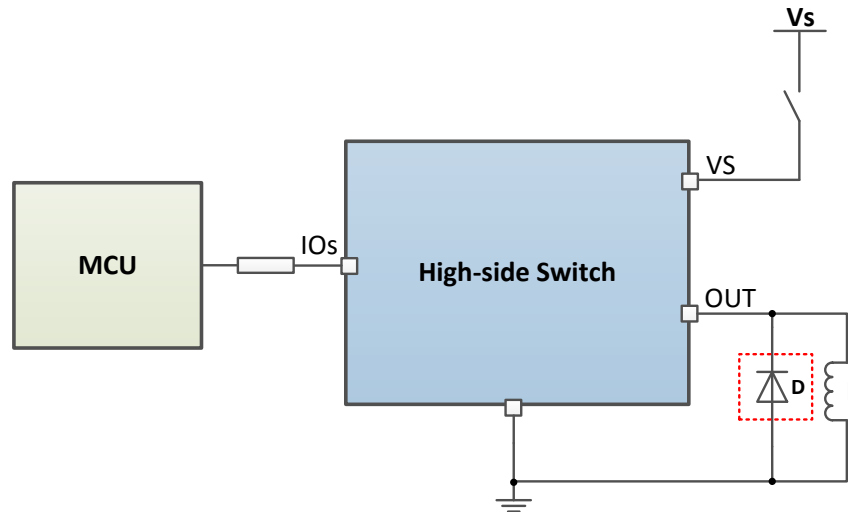

Figure 6-16. Protection for Loss of Power Supply

### 6.3.6.5 Reverse-Current Protection

Reverse current occurs in two conditions: short to supply and reverse polarity.

- When a short to the supply occurs, there is only reverse current through the body diode.  $I_{R(1)}$  specifies the limit of the reverse current.
- In a reverse-polarity condition, there are reverse currents through the body diode and the device GND pin.  $I_{R(2)}$  specifies the limit of the reverse current.

To protect the device, TI recommends two types of external circuitry.

- Adding a blocking diode (method 1). Both the device and load are protected when in reverse polarity.
- Adding a GND network (method 2). The reverse current through the device GND is blocked. The reverse current through the FET is limited by the load itself. TI recommends a resistor in parallel with the diode as a GND network. The recommended configuration is a 1k $\Omega$  resistor in parallel with a >100mA diode. The reverse current protection diode in the GND network forward voltage must be less than 0.6V in any circumstances. In addition a minimum resistance of 4.7K is recommended on the I/O pins.

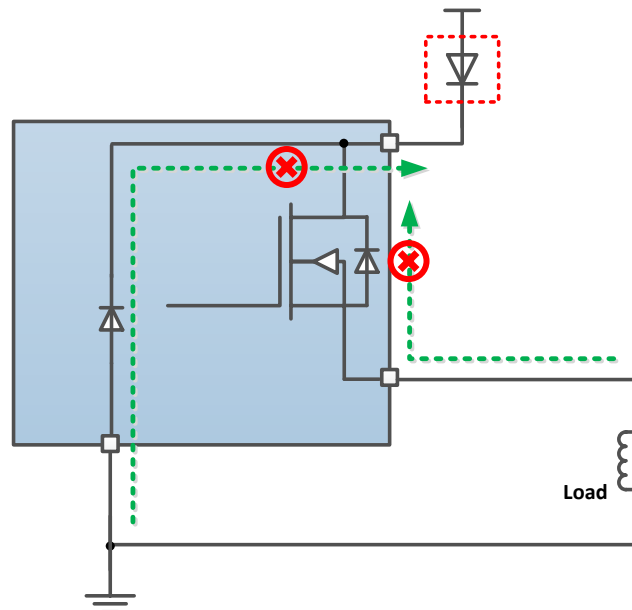
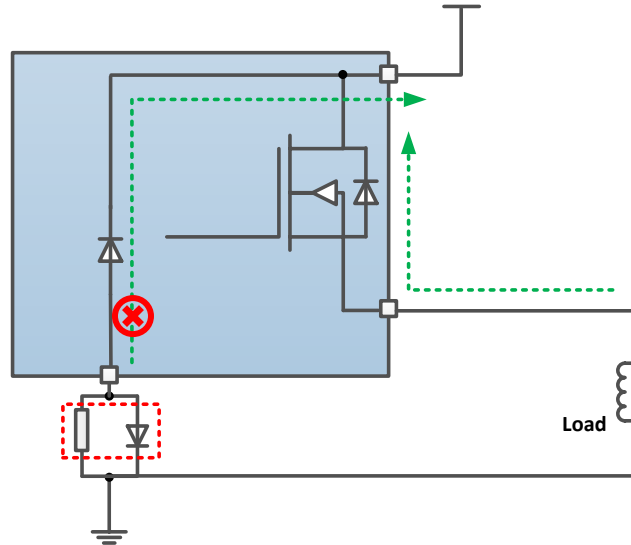

Figure 6-17. Reverse-Current External Protection, Method 1



**Figure 6-18. Reverse-Current External Protection, Method 2**

**6.3.6.6 MCU I/O Protection**

TI recommends series resistors to protect the microcontroller, for example, 4.7kΩ when using a 3.3V microcontroller and 10kΩ for a 5V microcontroller.

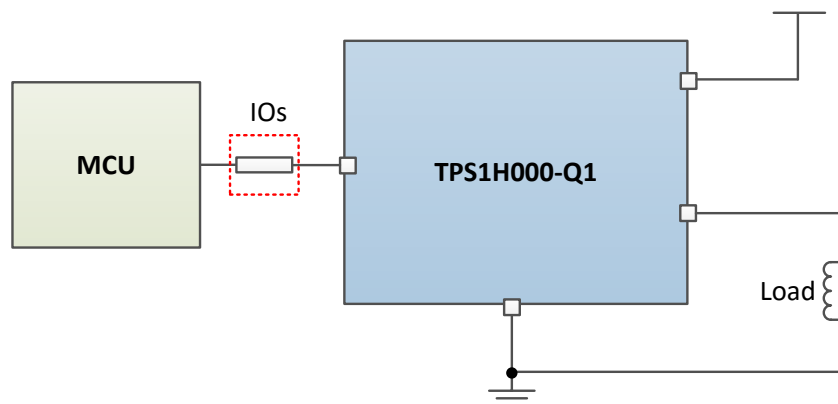
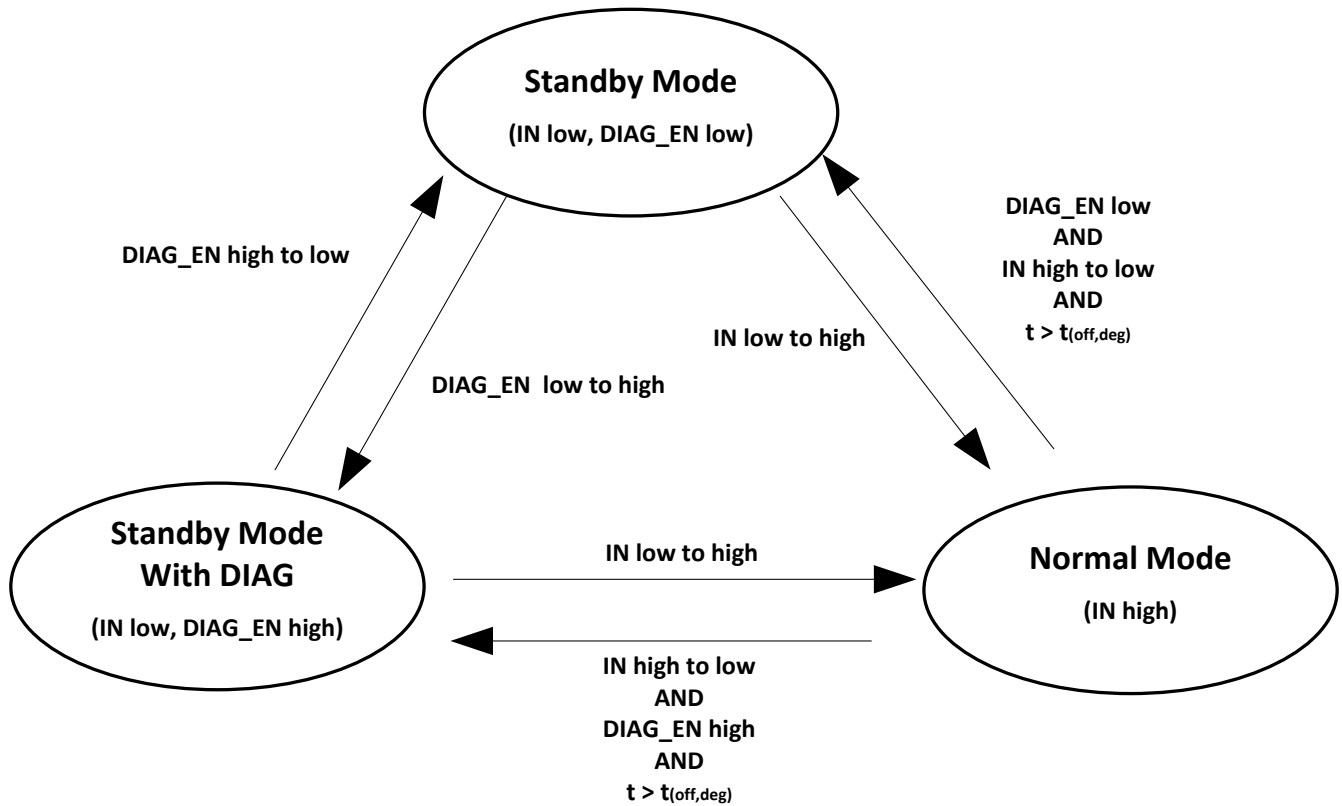

**Figure 6-19. MCU I/O External Protection**

**6.4 Device Functional Modes**

**6.4.1 Working Modes**

The device has three working modes, the normal mode, the standby mode, and the standby mode with diagnostics, as shown in [Figure 6-20](#).



**Figure 6-20. Working Modes**

#### 6.4.1.1 Normal Mode

When IN is high, the device enters normal mode.

#### 6.4.1.2 Standby Mode

When IN is low and DIAG\_EN is low, the device enters standby mode with ultra-low power consumption.

#### 6.4.1.3 Standby Mode With Diagnostics

When IN is low and DIAG\_EN is high, the device enters standby mode with diagnostics. The device still supports open-load and short-to-battery detection even when IN is low.

## 7 Application and Implementation

### Note

Information in the following applications sections is not part of the TI component specification, and TI does not warrant its accuracy or completeness. TI's customers are responsible for determining suitability of components for their purposes, as well as validating and testing their design implementation to confirm system functionality.

### 7.1 Application Information

The TPS1H000-Q1 device is a smart high-side switch, with an internal charge pump and single-channel integrated NMOS power FET. The adjustable current-limit function greatly improves the reliability of the whole system. Full diagnostic features enable intelligent control of the load. The TPS1H000-Q1 device can be used for a wide variety of resistive, inductive, and capacitive loads, including LEDs, relays, and sub-modules.

### 7.2 Typical Application

Figure 7-1 shows an example of how to design the external circuitry parameters.

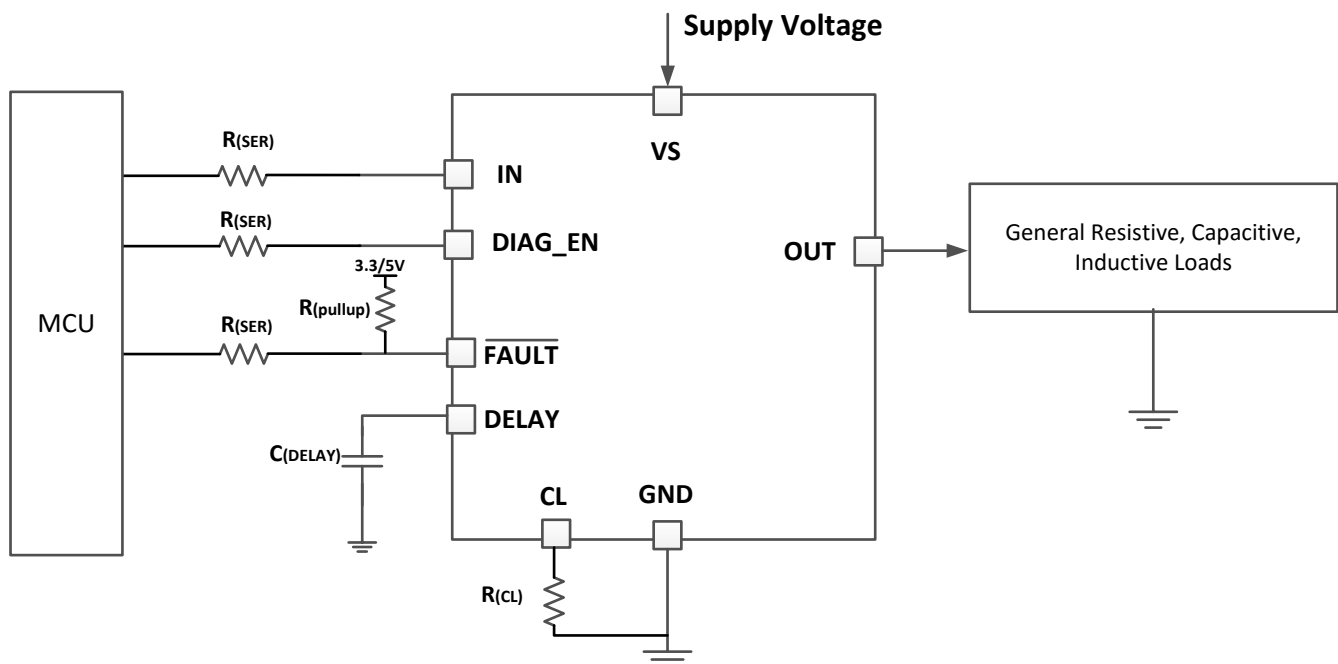

Figure 7-1. Typical Application Circuitry

#### 7.2.1 Design Requirements

- $V_{VS}$  range from 6V to 18V
- Nominal current of 100mA
- Expected current limit value of 500mA
- Thermal sensitive system, when current limit occurs, the output latches off after 0.2s. The 0.2s is to verify the safe start-up for a capacitive load, clamping the inrush current but without latch-off during start-up.
- Full diagnostics with 5V MCU, including on-state open-load detection, short-to-GND or overcurrent detection, and thermal shutdown detection

#### 7.2.2 Detailed Design Procedure

To set the adjustable current limit value at 500mA, calculate  $R_{(CL)}$  as follows:

$$R_{(CL)} = \frac{V_{CL(th)} \times K_{(CL)}}{I_{OUT}} = \frac{0.8 \times 600}{0.5} = 960\Omega \quad (5)$$

To set the adjustable latch-off delay at 0.2s, calculate  $C_{(DELAY)}$  as follows:

$$t_{dl} = t_{CL(deg)} + t_{dl1} + t_{dl2} = 0.2 \approx t_{dl2} \quad (6)$$

$$C_{DELAY} = \frac{I_{dl(chg)} \times t_{dl2}}{V_{dl(ref)}} = \frac{4.5 \times 0.2}{1.45} \times 10^{-6} = 0.62\mu F$$

TI recommends  $R_{(SER)} = 10k\Omega$  for a 5V MCU, and  $R_{(pullup)} = 10k\Omega$  as the pullup resistor.

### 7.2.3 Application Curves

The following curves are test examples of hard short conditions. The load is 0.1A and the current limit value is 0.5A. Figure 7-2 shows a waveform of the latch-off mode. Figure 7-3 shows a waveform of the auto-retry mode.

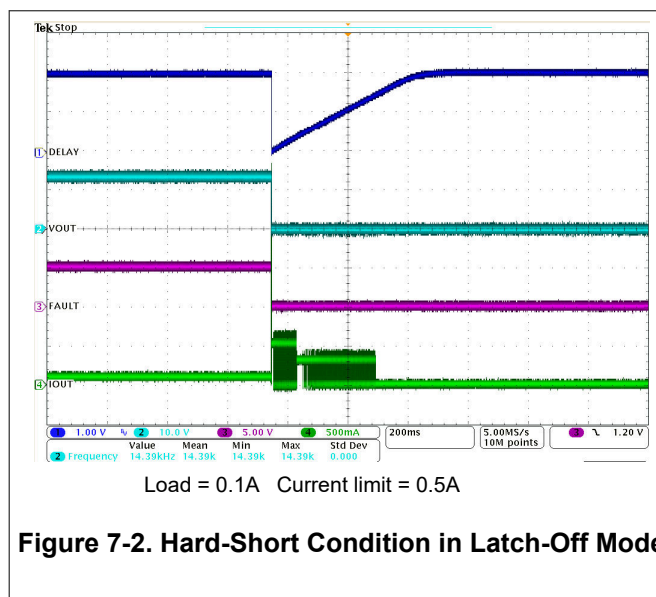

Figure 7-2. Hard-Short Condition in Latch-Off Mode

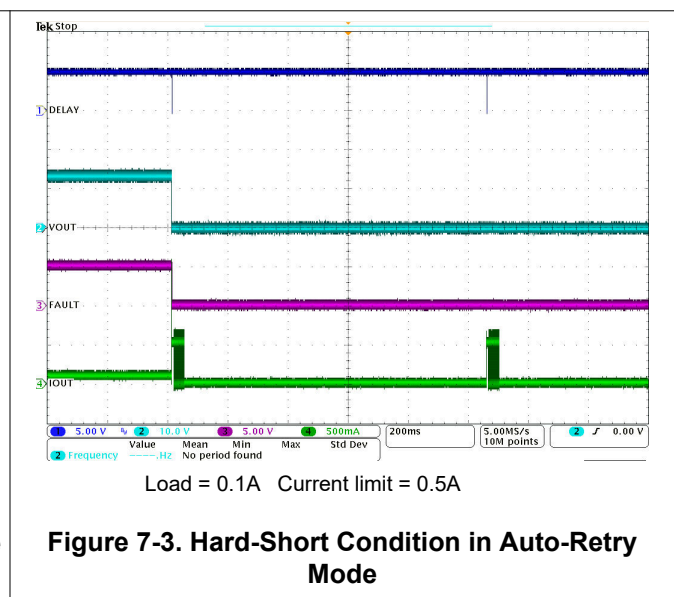

Figure 7-3. Hard-Short Condition in Auto-Retry Mode

## 7.3 Power Supply Recommendations

Use the device for both 12V and 24V applications. The normal power supply connection is a 12V or 24V system.

## 7.4 Layout

### 7.4.1 Layout Guidelines

To prevent thermal shutdown,  $T_j$  must be less than 175°C. If the output current is very high, the power dissipation can be large. However, the PCB layout is very important. Good PCB design can optimize heat transfer, which is absolutely essential for the long-term reliability of the device.

- Maximize the copper coverage on the PCB to increase the thermal conductivity of the board. The major heat-flow path from the package to the ambient is through the copper on the PCB. Maximum copper is extremely important when there are not any heat sinks attached to the PCB on the other side of the board opposite the package.
- Add as many thermal vias as possible directly under the package thermal pad to optimize the thermal conductivity of the board.
- All thermal vias must either be plated shut or plugged and capped on both sides of the board to prevent solder voids. To establish reliability and performance, the solder coverage must be at least 85%.

### 7.4.2 Layout Example

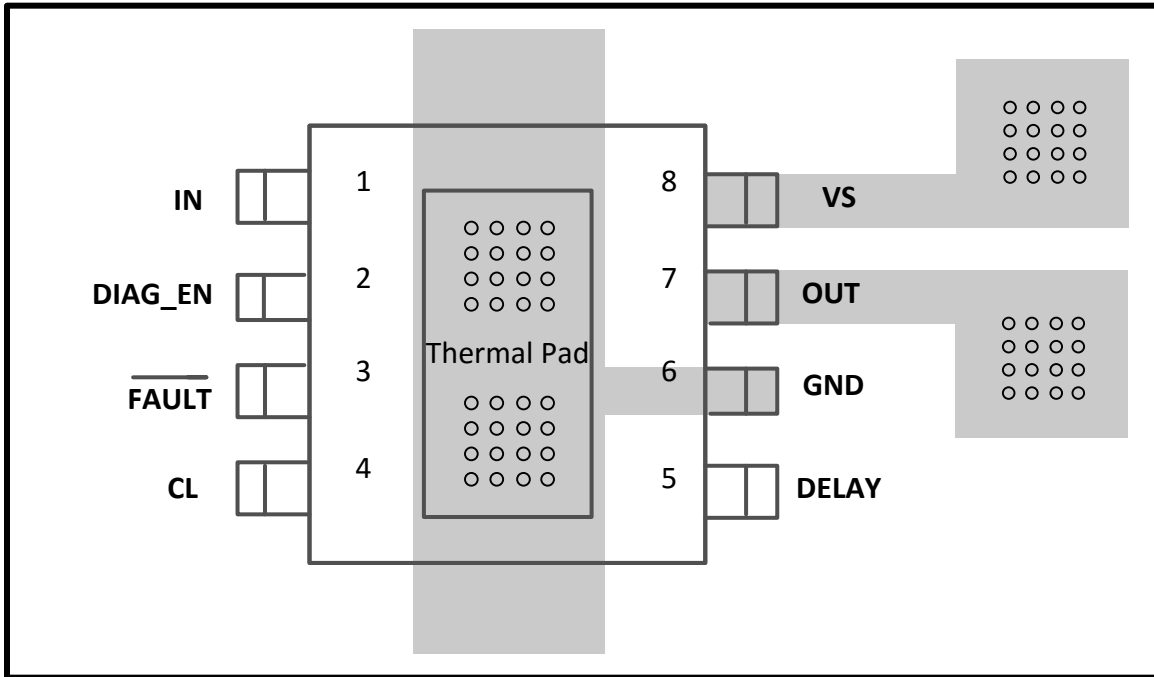

Figure 7-4. Layout Example

## 8 Device and Documentation Support

### 8.1 Receiving Notification of Documentation Updates

To receive notification of documentation updates, navigate to the device product folder on [ti.com](http://ti.com). Click on *Notifications* to register and receive a weekly digest of any product information that has changed. For change details, review the revision history included in any revised document.

### 8.2 Support Resources

[TI E2E™ support forums](#) are an engineer's go-to source for fast, verified answers and design help — straight from the experts. Search existing answers or ask your own question to get the quick design help you need.

Linked content is provided "AS IS" by the respective contributors. They do not constitute TI specifications and do not necessarily reflect TI's views; see TI's [Terms of Use](#).

### 8.3 Trademarks

PowerPAD™ and TI E2E™ are trademarks of Texas Instruments. All trademarks are the property of their respective owners.

### 8.4 Electrostatic Discharge Caution



This integrated circuit can be damaged by ESD. Texas Instruments recommends that all integrated circuits be handled with appropriate precautions. Failure to observe proper handling and installation procedures can cause damage.

ESD damage can range from subtle performance degradation to complete device failure. Precision integrated circuits may be more susceptible to damage because very small parametric changes could cause the device not to meet its published specifications.

### 8.5 Glossary

[TI Glossary](#) This glossary lists and explains terms, acronyms, and definitions.

## 9 Revision History

NOTE: Page numbers for previous revisions may differ from page numbers in the current version.

<b>Changes from Revision D (December 2024) to Revision E (May 2026)</b>	<b>Page</b>
• Changed $R_{\theta JC(top)}$ from 50.2°C/W to 74.0°C/W.....	5
• Changed $\psi_{JT}$ from 0.8°C/W to 3.8°C/W.....	5
• Changed $R_{\theta JC(bot)}$ from 7.1°C/W to 7.7°C/W.....	5
• Updated exposed pad dimensions to relax minimum limit.....	25

<b>Changes from Revision C (June 2019) to Revision D (December 2024)</b>	<b>Page</b>
• Updated the numbering format for tables, figures, and cross-references throughout the document.....	1
• Updated maximum ratings of VS pin and IN/DIAG_EN pins to 42V in the <a href="#">Absolute Maximum Ratings</a> table...	4

## 10 Mechanical, Packaging, and Orderable Information

The following pages include mechanical, packaging, and orderable information. This information is the most-current data available for the designated device. This data is subject to change without notice and without revision of this document. For browser-based versions of this data sheet, see the left-hand navigation pane.

**PACKAGING INFORMATION**

Orderable part number	Status (1)	Material type (2)	Package   Pins	Package qty   Carrier	RoHS (3)	Lead finish/ Ball material (4)	MSL rating/ Peak reflow (5)	Op temp (°C)	Part marking (6)
<a href="#">TPS1H000AQDGNRQ1</a>	Active	Production	HVSSOP (DGN)   8	2500   LARGE T&R	Yes	NIPDAU   NIPDAUAG	Level-2-260C-1 YEAR	-40 to 125	17SX
TPS1H000AQDGNRQ1.A	Active	Production	HVSSOP (DGN)   8	2500   LARGE T&R	Yes	NIPDAU	Level-2-260C-1 YEAR	-40 to 125	17SX

(1) **Status:** For more details on status, see our [product life cycle](#).

(2) **Material type:** When designated, preproduction parts are prototypes/experimental devices, and are not yet approved or released for full production. Testing and final process, including without limitation quality assurance, reliability performance testing, and/or process qualification, may not yet be complete, and this item is subject to further changes or possible discontinuation. If available for ordering, purchases will be subject to an additional waiver at checkout, and are intended for early internal evaluation purposes only. These items are sold without warranties of any kind.

(3) **RoHS values:** Yes, No, RoHS Exempt. See the [TI RoHS Statement](#) for additional information and value definition.

(4) **Lead finish/Ball material:** Parts may have multiple material finish options. Finish options are separated by a vertical ruled line. Lead finish/Ball material values may wrap to two lines if the finish value exceeds the maximum column width.

(5) **MSL rating/Peak reflow:** The moisture sensitivity level ratings and peak solder (reflow) temperatures. In the event that a part has multiple moisture sensitivity ratings, only the lowest level per JEDEC standards is shown. Refer to the shipping label for the actual reflow temperature that will be used to mount the part to the printed circuit board.

(6) **Part marking:** There may be an additional marking, which relates to the logo, the lot trace code information, or the environmental category of the part.

Multiple part markings will be inside parentheses. Only one part marking contained in parentheses and separated by a "~" will appear on a part. If a line is indented then it is a continuation of the previous line and the two combined represent the entire part marking for that device.

**Important Information and Disclaimer:**The information provided on this page represents TI's knowledge and belief as of the date that it is provided. TI bases its knowledge and belief on information provided by third parties, and makes no representation or warranty as to the accuracy of such information. Efforts are underway to better integrate information from third parties. TI has taken and continues to take reasonable steps to provide representative and accurate information but may not have conducted destructive testing or chemical analysis on incoming materials and chemicals. TI and TI suppliers consider certain information to be proprietary, and thus CAS numbers and other limited information may not be available for release.

In no event shall TI's liability arising out of such information exceed the total purchase price of the TI part(s) at issue in this document sold by TI to Customer on an annual basis.

**TAPE AND REEL INFORMATION**

**QUADRANT ASSIGNMENTS FOR PIN 1 ORIENTATION IN TAPE**

\*All dimensions are nominal

Device	Package Type	Package Drawing	Pins	SPQ	Reel Diameter (mm)	Reel Width W1 (mm)	A0 (mm)	B0 (mm)	K0 (mm)	P1 (mm)	W (mm)	Pin1 Quadrant
TPS1H000AQDGNRQ1	HVSSOP	DGN	8	2500	330.0	12.4	5.3	3.4	1.4	8.0	12.0	Q1

**TAPE AND REEL BOX DIMENSIONS**

\*All dimensions are nominal

Device	Package Type	Package Drawing	Pins	SPQ	Length (mm)	Width (mm)	Height (mm)
TPS1H000AQDGNRQ1	HVSSOP	DGN	8	2500	366.0	364.0	50.0

## GENERIC PACKAGE VIEW

**DGN 8**

**PowerPAD™ HVSSOP - 1.1 mm max height**

3 x 3, 0.65 mm pitch

SMALL OUTLINE PACKAGE

This image is a representation of the package family, actual package may vary.  
Refer to the product data sheet for package details.

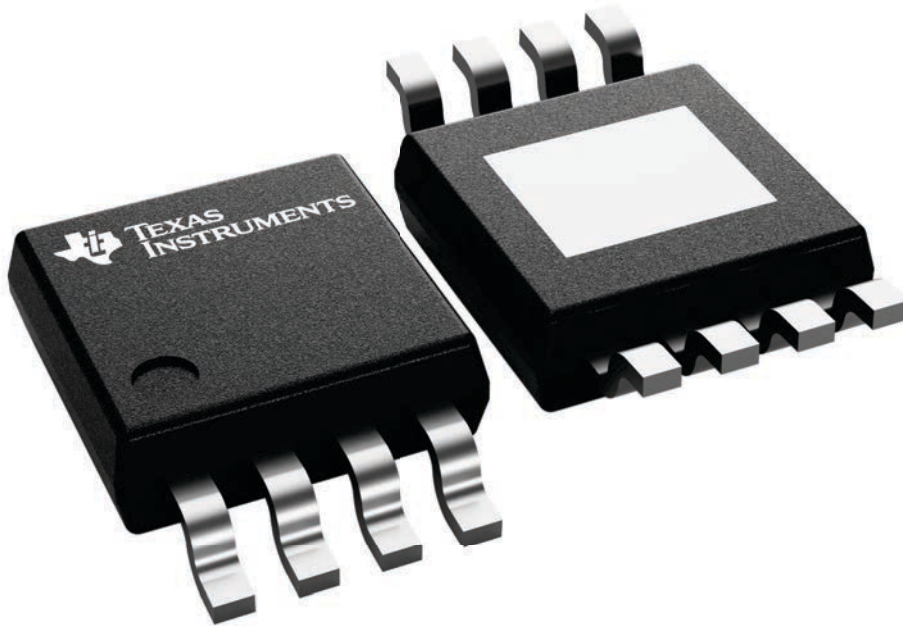

4225482/B

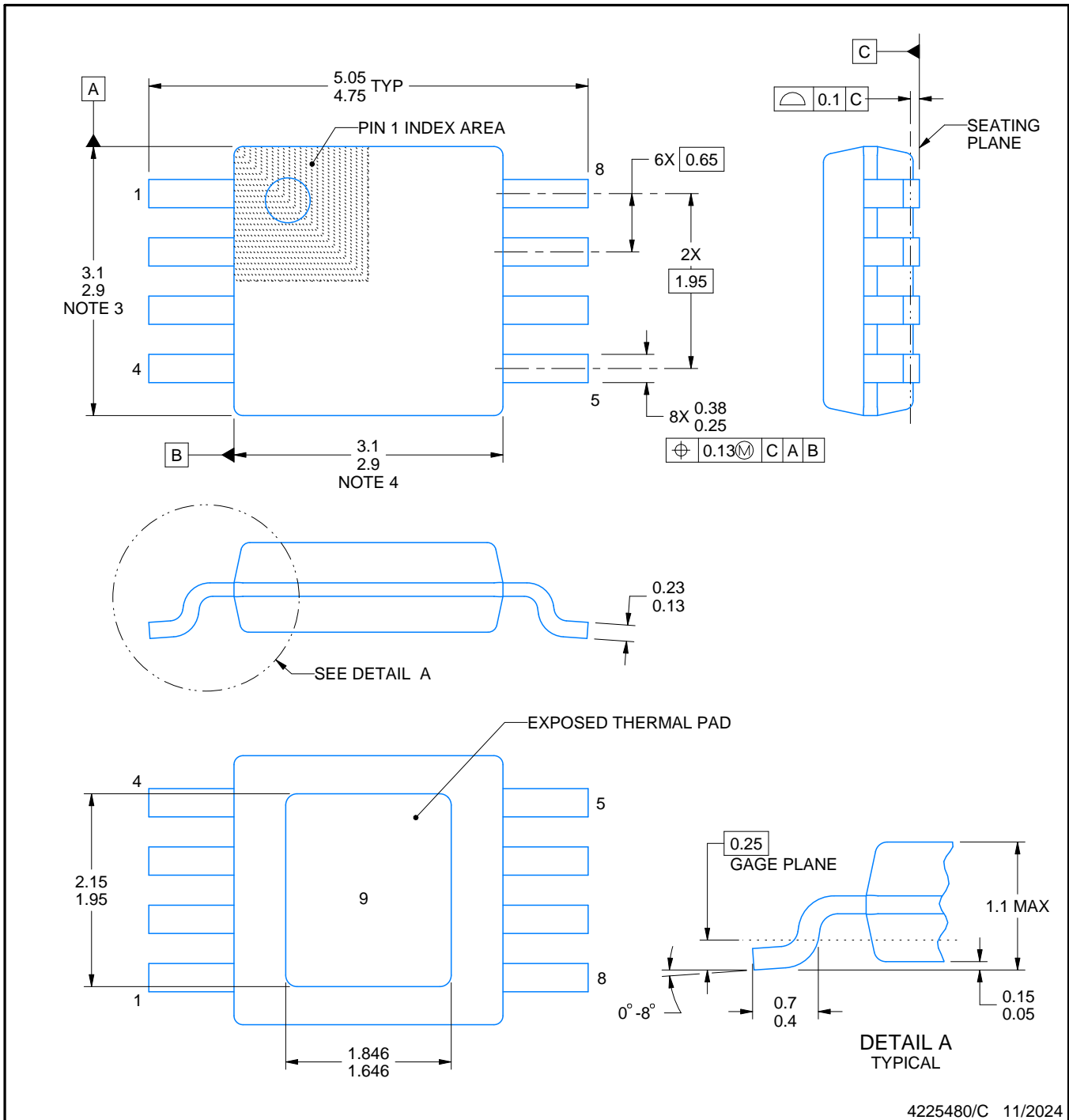
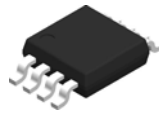

4225480/C 11/2024

NOTES:

PowerPAD is a trademark of Texas Instruments.

1. All linear dimensions are in millimeters. Any dimensions in parenthesis are for reference only. Dimensioning and tolerancing per ASME Y14.5M.
2. This drawing is subject to change without notice.
3. This dimension does not include mold flash, protrusions, or gate burrs. Mold flash, protrusions, or gate burrs shall not exceed 0.15 mm per side.
4. This dimension does not include interlead flash. Interlead flash shall not exceed 0.25 mm per side.
5. Reference JEDEC registration MO-187.

# EXAMPLE BOARD LAYOUT

DGN0008G

PowerPAD™ HVSSOP - 1.1 mm max height

SMALL OUTLINE PACKAGE

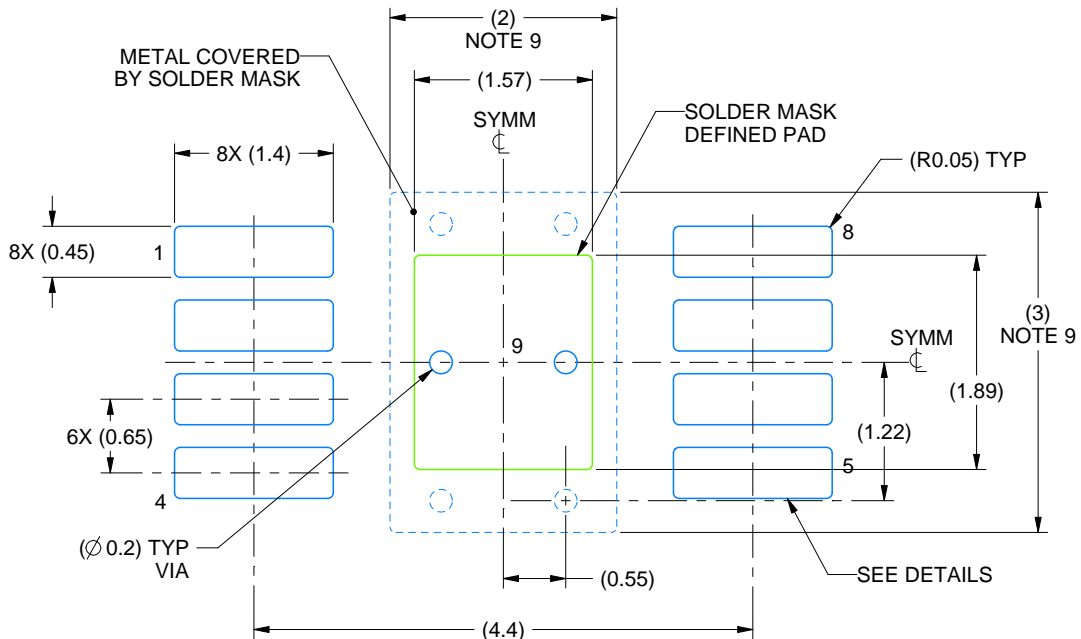

LAND PATTERN EXAMPLE  
EXPOSED METAL SHOWN  
SCALE: 15X

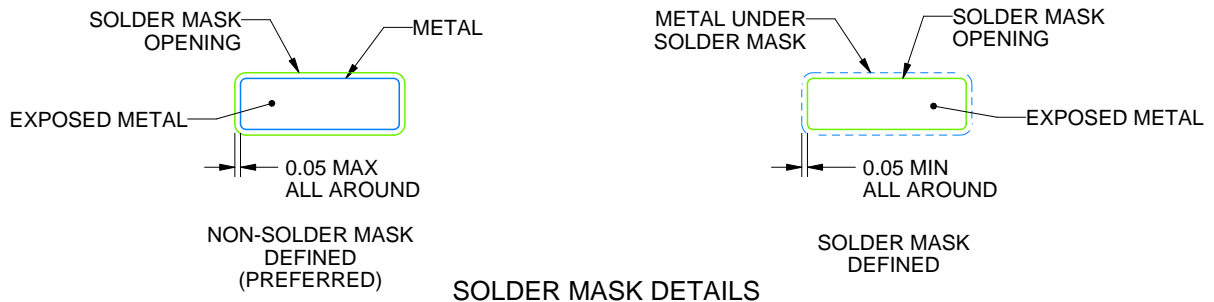

4225480/C 11/2024

NOTES: (continued)

6. Publication IPC-7351 may have alternate designs.
7. Solder mask tolerances between and around signal pads can vary based on board fabrication site.
8. Vias are optional depending on application, refer to device data sheet. If any vias are implemented, refer to their locations shown on this view. It is recommended that vias under paste be filled, plugged or tented.
9. Size of metal pad may vary due to creepage requirement.

# EXAMPLE STENCIL DESIGN

DGN0008G

PowerPAD™ HVSSOP - 1.1 mm max height

SMALL OUTLINE PACKAGE

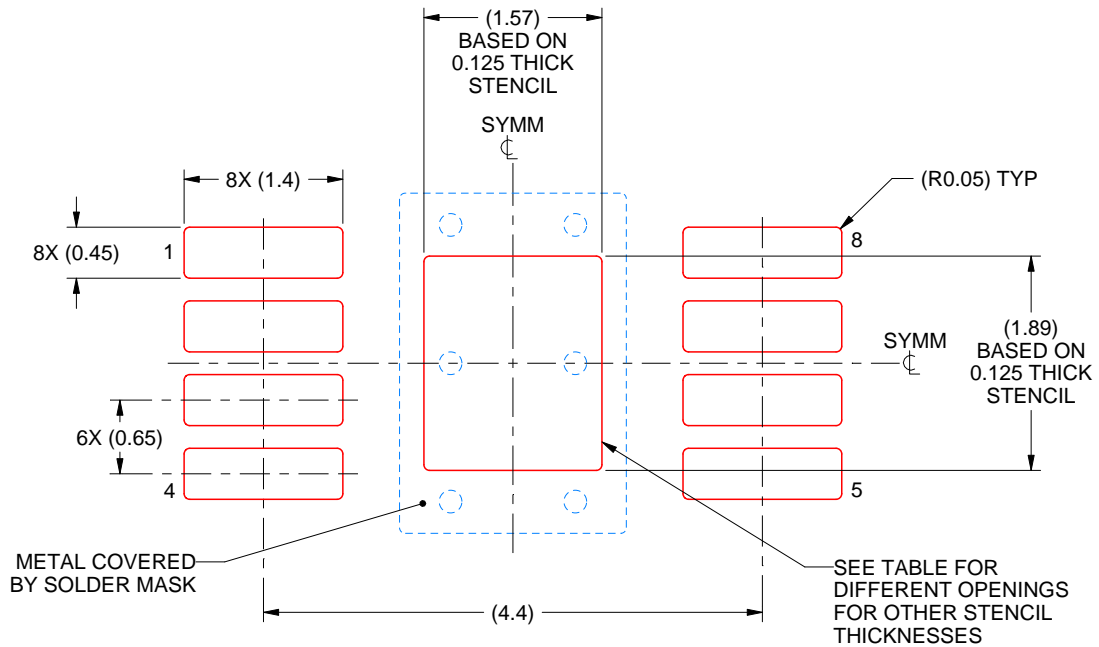

**SOLDER PASTE EXAMPLE**  
EXPOSED PAD 9:  
100% PRINTED SOLDER COVERAGE BY AREA  
SCALE: 15X

STENCIL THICKNESS	SOLDER STENCIL OPENING
0.1	1.76 X 2.11
0.125	1.57 X 1.89 (SHOWN)
0.15	1.43 X 1.73
0.175	1.33 X 1.60

4225480/C 11/2024

NOTES: (continued)

10. Laser cutting apertures with trapezoidal walls and rounded corners may offer better paste release. IPC-7525 may have alternate design recommendations.
11. Board assembly site may have different recommendations for stencil design.

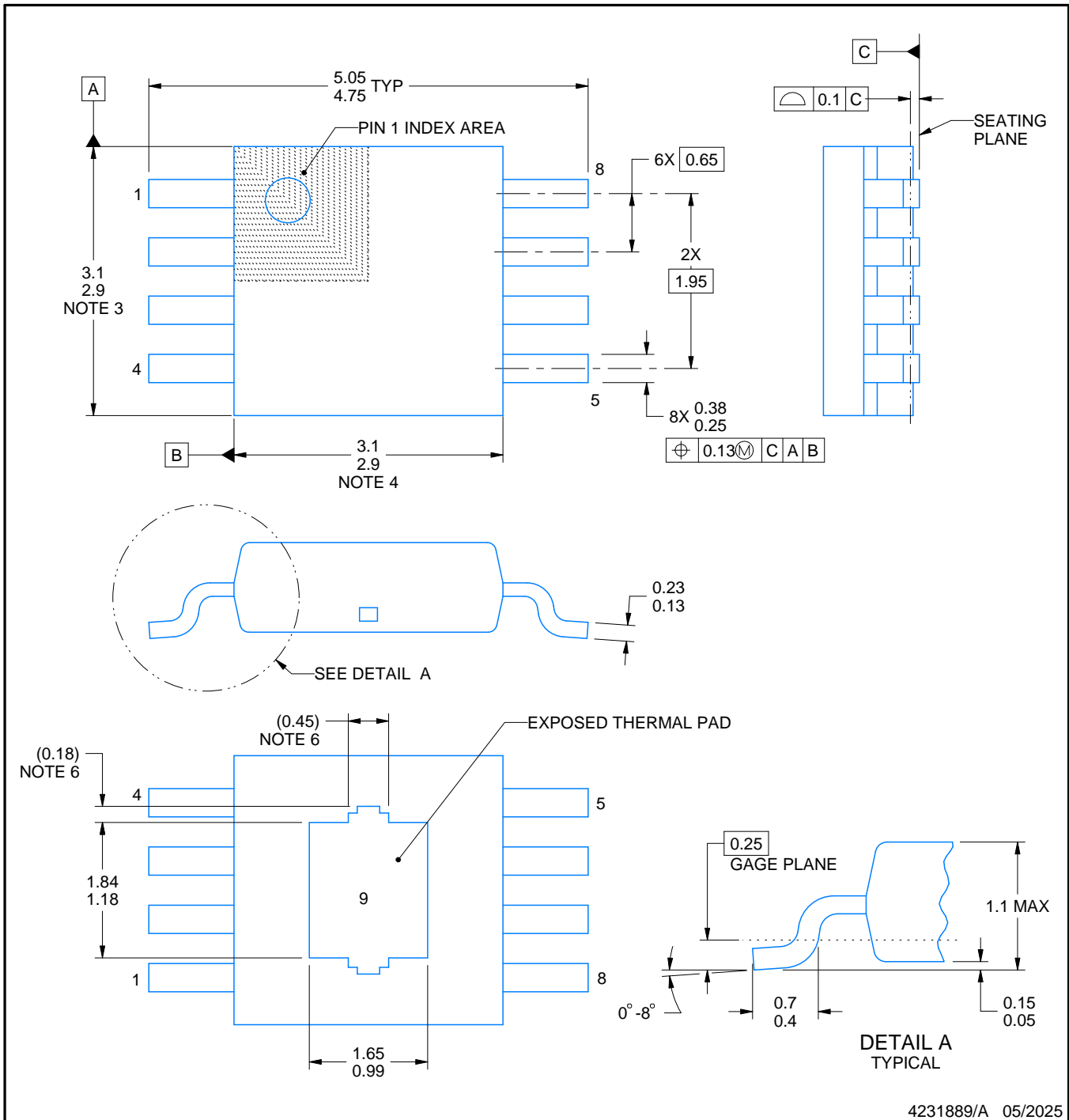

4231889/A 05/2025

NOTES:

PowerPAD is a trademark of Texas Instruments.

1. All linear dimensions are in millimeters. Any dimensions in parenthesis are for reference only. Dimensioning and tolerancing per ASME Y14.5M.
2. This drawing is subject to change without notice.
3. This dimension does not include mold flash, protrusions, or gate burrs. Mold flash, protrusions, or gate burrs shall not exceed 0.15 mm per side.
4. This dimension does not include interlead flash. Interlead flash shall not exceed 0.25 mm per side.
5. Reference JEDEC registration MO-187.
6. Features may differ or may not be present.



# EXAMPLE STENCIL DESIGN

DGN0008K

PowerPAD™ VSSOP - 1.1 mm max height

SMALL OUTLINE PACKAGE

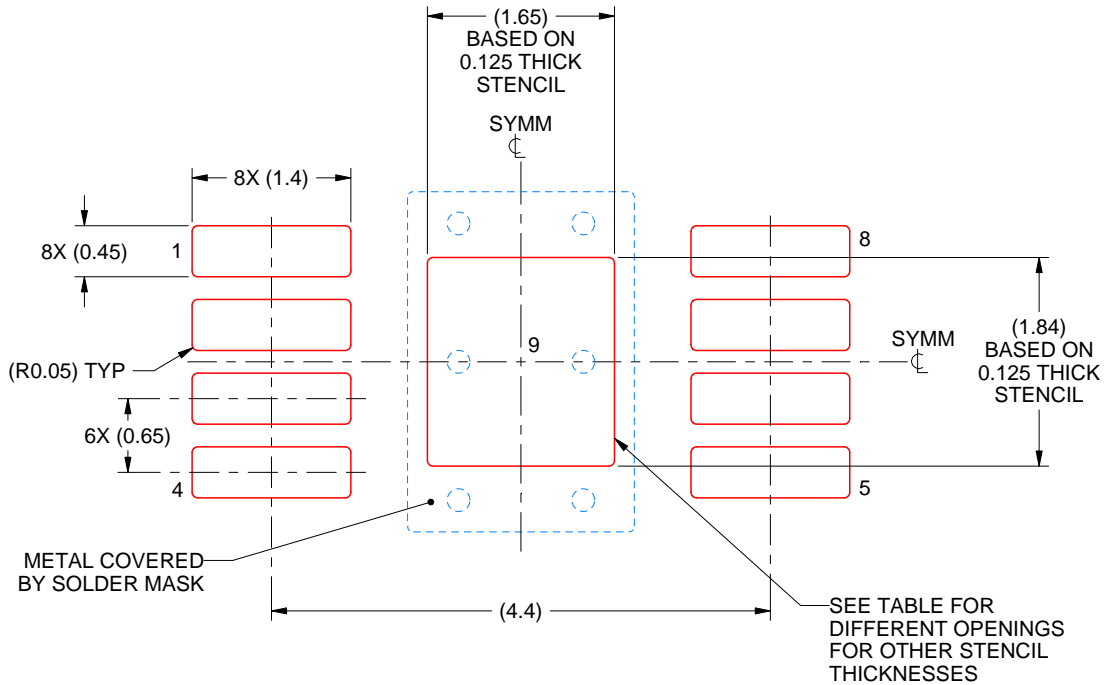

**SOLDER PASTE EXAMPLE**  
 EXPOSED PAD 9:  
 100% PRINTED SOLDER COVERAGE BY AREA  
 SCALE: 15X

STENCIL THICKNESS	SOLDER STENCIL OPENING
0.1	1.84 X 2.06
0.125	1.65 X 1.84 (SHOWN)
0.15	1.51 X 1.68
0.175	1.39 X 1.56

4231889/A 05/2025

NOTES: (continued)

11. Laser cutting apertures with trapezoidal walls and rounded corners may offer better paste release. IPC-7525 may have alternate design recommendations.
12. Board assembly site may have different recommendations for stencil design.

## IMPORTANT NOTICE AND DISCLAIMER

TI PROVIDES TECHNICAL AND RELIABILITY DATA (INCLUDING DATASHEETS), DESIGN RESOURCES (INCLUDING REFERENCE DESIGNS), APPLICATION OR OTHER DESIGN ADVICE, WEB TOOLS, SAFETY INFORMATION, AND OTHER RESOURCES "AS IS" AND WITH ALL FAULTS, AND DISCLAIMS ALL WARRANTIES, EXPRESS AND IMPLIED, INCLUDING WITHOUT LIMITATION ANY IMPLIED WARRANTIES OF MERCHANTABILITY, FITNESS FOR A PARTICULAR PURPOSE OR NON-INFRINGEMENT OF THIRD PARTY INTELLECTUAL PROPERTY RIGHTS.

These resources are intended for skilled developers designing with TI products. You are solely responsible for (1) selecting the appropriate TI products for your application, (2) designing, validating and testing your application, and (3) ensuring your application meets applicable standards, and any other safety, security, regulatory or other requirements.

These resources are subject to change without notice. TI grants you permission to use these resources only for development of an application that uses the TI products described in the resource. Other reproduction and display of these resources is prohibited. No license is granted to any other TI intellectual property right or to any third party intellectual property right. TI disclaims responsibility for, and you fully indemnify TI and its representatives against any claims, damages, costs, losses, and liabilities arising out of your use of these resources.

TI's products are provided subject to [TI's Terms of Sale](#), [TI's General Quality Guidelines](#), or other applicable terms available either on [ti.com](http://ti.com) or provided in conjunction with such TI products. TI's provision of these resources does not expand or otherwise alter TI's applicable warranties or warranty disclaimers for TI products. Unless TI explicitly designates a product as custom or customer-specified, TI products are standard, catalog, general purpose devices.

TI objects to and rejects any additional or different terms you may propose.

Copyright © 2026, Texas Instruments Incorporated

Last updated 10/2025