

TPS26743E-Q1 Automotive Single-port USB Type-C® PD Controller with 240W EPR and DisplayPort™ over USB Type-C®

1 Features

- AEC-Q100 test guidance with the following:
 - Device temperature grade 1: -40°C to 125°C ambient operating temperature range
 - Device HBM ESD classification level:
 - Level 2 and level 3A
 - Device CDM ESD classification level:
 - Level C2a and C2b
- TPS26743E-Q1 is a fully configurable single-port PD3.2 source controller.
 - Extended power range (EPR) support
 - 40V tolerant VBUS
 - 24V tolerant CC and DP/DM pins
 - GUI tool to easily configure for various applications
 - Programmable power supply (PPS) support (source)
- USB Type-C power delivery (PD) controller
 - USB PD R3.2 compliant
 - USB Type-C R2.4 compliant
 - DisplayPort alternate mode support
 - Sink mode support
 - 20 configurable GPIOs
 - Cable attach and orientation detection
 - Integrated VCONN switch. No external supply required to read eMarker
 - Physical layer and policy engine
 - Integrated LDO with input up to 40V
 - One I²C controller port (I2C2)
 - Two I²C target ports (I2C1, I2C3)
 - UART and LIN support
 - Closed-chassis debugging
- Integrated flash memory supporting updates via I²C gated by an authentication check
 - Closed-chassis flash updates via I2C4
- System power management
 - Across multiple ports and multiple devices
 - Thermal foldback
 - Power foldback
- Liquid detection and corrosion mitigation

2 Applications

- [Automotive USB charging](#)
- [Automotive media hub](#)
- [Automotive head unit](#)
- [Automotive display module](#)
- Sink-only applications

3 Description

The TPS26743E-Q1 is a stand-alone single-port USB Type-C and power delivery (PD) source controller for any automotive USB-C port application including extended power range (EPR) voltages. The TPS26743E-Q1 is capable of supporting all USB-PD power supply negotiation options for standard power range (SPR) and EPR. The TPS26743E-Q1 automatically identifies USB-C cable capabilities, and adjusts for the maximum current allowed by the cable, without requiring an external 5V supply for VCONN. The TPS26743E-Q1 supports DisplayPort over USB-C and legacy D+/D- charging.

The TPS26743E-Q1 controls a DC/DC via I²C or PWM to achieve a complete USB-C PD application. The TPS26743E-Q1 has SYNC outputs to keep external DC/DC switching out-of-phase for each port, with dual-random spread-spectrum (DRSS).

The TPS26743E-Q1 has integrated protections for thermal and input voltage monitoring for power foldback, VBUS high/low monitoring, and liquid detection along with corrosion mitigation.

The TPS26743E-Q1 also supports USB-C Alternate Modes such as DisplayPort. The TPS26743E-Q1 offers multiple interface options for the system including I²C and LIN support, along with configurable GPIOs.

Package Information

PART NUMBER	PACKAGE ⁽¹⁾	PACKAGE SIZE (NOM)
TPS26743E-Q1	32-QFN (RHB)	5mm x 5mm

(1) For all available packages, see the orderable addendum at the end of the datasheet.

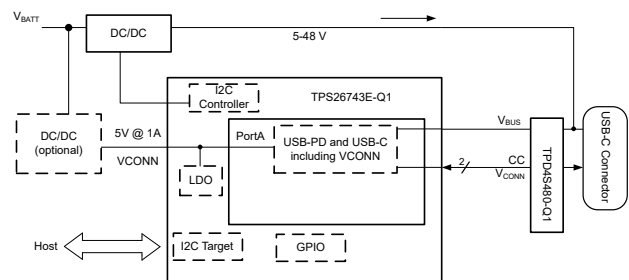

4 Device and Documentation Support

TI offers an extensive line of development tools. Tools and software to evaluate the performance of the device, generate code, and develop applications are listed below.

4.1 Documentation Support

4.1.1 Related Documentation

- [USB-PD Specifications](#)
- [USB Power Delivery Specification](#)

4.2 Receiving Notification of Documentation Updates

To receive notification of documentation updates, navigate to the device product folder on ti.com. Click on *Notifications* to register and receive a weekly digest of any product information that has changed. For change details, review the revision history included in any revised document.

4.3 Support Resources

[TI E2E™ support forums](#) are an engineer's go-to source for fast, verified answers and design help — straight from the experts. Search existing answers or ask your own question to get the quick design help you need.

Linked content is provided "AS IS" by the respective contributors. They do not constitute TI specifications and do not necessarily reflect TI's views; see TI's [Terms of Use](#).

4.4 Trademarks

DisplayPort™ is a trademark of Video Electronics Standards Association..

TI E2E™ is a trademark of Texas Instruments.

USB Type-C® are registered trademarks of USB Implementers Forum.

All trademarks are the property of their respective owners.

4.5 Electrostatic Discharge Caution



This integrated circuit can be damaged by ESD. Texas Instruments recommends that all integrated circuits be handled with appropriate precautions. Failure to observe proper handling and installation procedures can cause damage.

ESD damage can range from subtle performance degradation to complete device failure. Precision integrated circuits may be more susceptible to damage because very small parametric changes could cause the device not to meet its published specifications.

4.6 Glossary

[TI Glossary](#) This glossary lists and explains terms, acronyms, and definitions.

5 Revision History

NOTE: Page numbers for previous revisions may differ from page numbers in the current version.

DATE	REVISION	NOTES
May 2026	*	Initial release

6 Mechanical, Packaging, and Orderable Information

The following pages include mechanical, packaging, and orderable information. This information is the most current data available for the designated devices. This data is subject to change without notice and revision of this document. For browser-based versions of this data sheet, refer to the left-hand navigation.

PACKAGING INFORMATION

Orderable part number	Status (1)	Material type (2)	Package Pins	Package qty Carrier	RoHS (3)	Lead finish/ Ball material (4)	MSL rating/ Peak reflow (5)	Op temp (°C)	Part marking (6)
TPS26743EAAQRHBRQ1	Active	Production	VQFN (RHB) 32	5000 LARGE T&R	Yes	NIPDAU	Level-2-260C-1 YEAR	-40 to 125	T26743E AA

(1) **Status:** For more details on status, see our [product life cycle](#).

(2) **Material type:** When designated, preproduction parts are prototypes/experimental devices, and are not yet approved or released for full production. Testing and final process, including without limitation quality assurance, reliability performance testing, and/or process qualification, may not yet be complete, and this item is subject to further changes or possible discontinuation. If available for ordering, purchases will be subject to an additional waiver at checkout, and are intended for early internal evaluation purposes only. These items are sold without warranties of any kind.

(3) **RoHS values:** Yes, No, RoHS Exempt. See the [TI RoHS Statement](#) for additional information and value definition.

(4) **Lead finish/Ball material:** Parts may have multiple material finish options. Finish options are separated by a vertical ruled line. Lead finish/Ball material values may wrap to two lines if the finish value exceeds the maximum column width.

(5) **MSL rating/Peak reflow:** The moisture sensitivity level ratings and peak solder (reflow) temperatures. In the event that a part has multiple moisture sensitivity ratings, only the lowest level per JEDEC standards is shown. Refer to the shipping label for the actual reflow temperature that will be used to mount the part to the printed circuit board.

(6) **Part marking:** There may be an additional marking, which relates to the logo, the lot trace code information, or the environmental category of the part.

Multiple part markings will be inside parentheses. Only one part marking contained in parentheses and separated by a "-" will appear on a part. If a line is indented then it is a continuation of the previous line and the two combined represent the entire part marking for that device.

Important Information and Disclaimer: The information provided on this page represents TI's knowledge and belief as of the date that it is provided. TI bases its knowledge and belief on information provided by third parties, and makes no representation or warranty as to the accuracy of such information. Efforts are underway to better integrate information from third parties. TI has taken and continues to take reasonable steps to provide representative and accurate information but may not have conducted destructive testing or chemical analysis on incoming materials and chemicals. TI and TI suppliers consider certain information to be proprietary, and thus CAS numbers and other limited information may not be available for release.

In no event shall TI's liability arising out of such information exceed the total purchase price of the TI part(s) at issue in this document sold by TI to Customer on an annual basis.

GENERIC PACKAGE VIEW

RHB 32

VQFN - 1 mm max height

5 x 5, 0.5 mm pitch

PLASTIC QUAD FLATPACK - NO LEAD

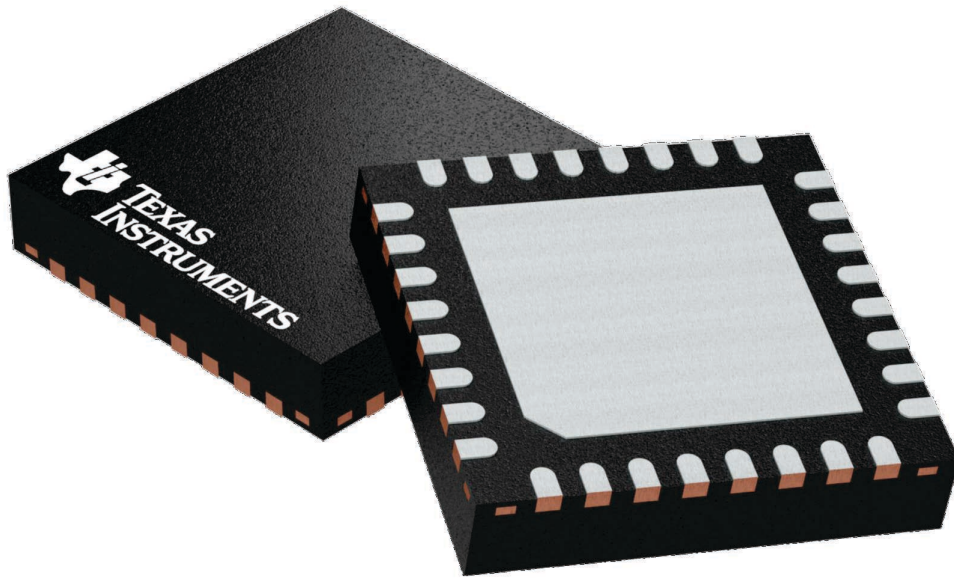

Images above are just a representation of the package family, actual package may vary.
Refer to the product data sheet for package details.

4224745/A

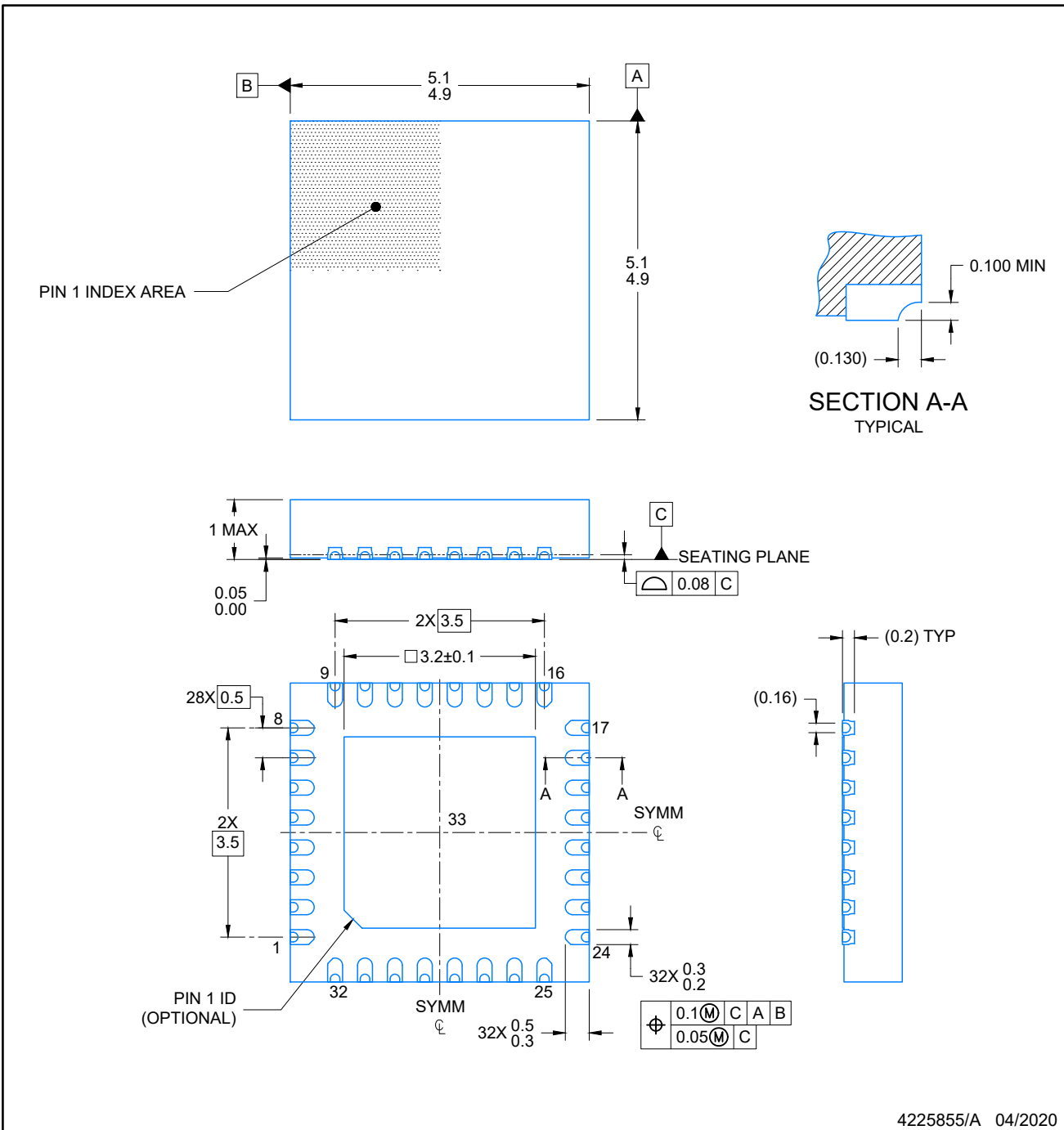

NOTES:

1. All linear dimensions are in millimeters. Any dimensions in parenthesis are for reference only. Dimensioning and tolerancing per ASME Y14.5M.
2. This drawing is subject to change without notice.
3. The package thermal pad must be soldered to the printed circuit board for optimal thermal and mechanical performance.

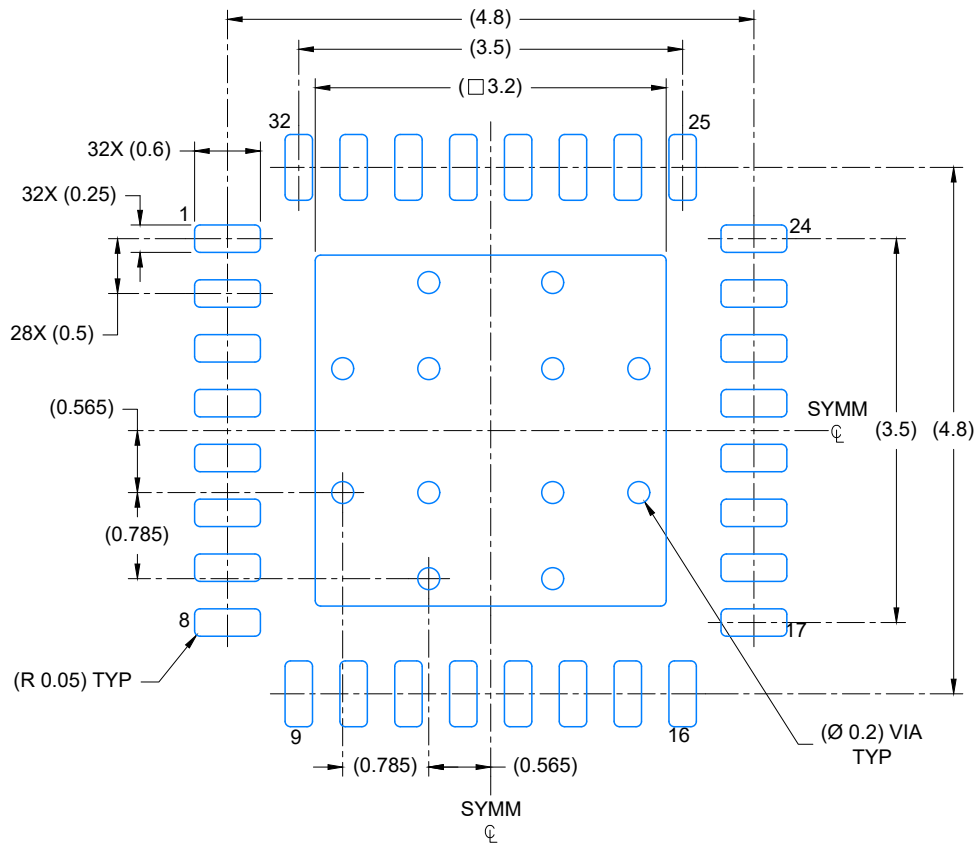

LAND PATTERN EXAMPLE
EXPOSED METAL SHOWN
SCALE: 15X

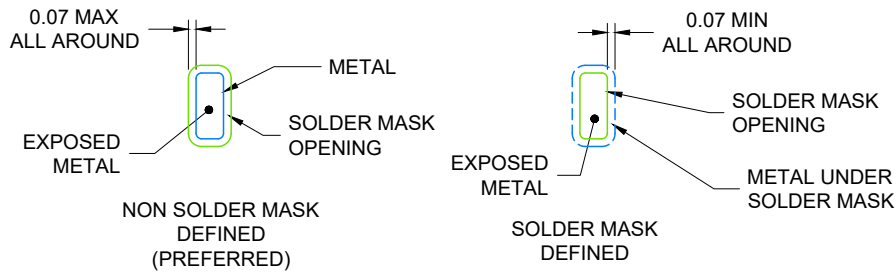

SOLDER MASK DETAILS

4225855/A 04/2020

NOTES: (continued)

4. This package is designed to be soldered to a thermal pad on the board. For more information, see Texas Instruments literature number SLUA271 (www.ti.com/lit/sluea271).
5. Vias are optional depending on application, refer to device data sheet. If any vias are implemented, refer to their locations shown on this view. It is recommended that vias under paste be filled, plugged or tented.

IMPORTANT NOTICE AND DISCLAIMER

TI PROVIDES TECHNICAL AND RELIABILITY DATA (INCLUDING DATASHEETS), DESIGN RESOURCES (INCLUDING REFERENCE DESIGNS), APPLICATION OR OTHER DESIGN ADVICE, WEB TOOLS, SAFETY INFORMATION, AND OTHER RESOURCES "AS IS" AND WITH ALL FAULTS, AND DISCLAIMS ALL WARRANTIES, EXPRESS AND IMPLIED, INCLUDING WITHOUT LIMITATION ANY IMPLIED WARRANTIES OF MERCHANTABILITY, FITNESS FOR A PARTICULAR PURPOSE OR NON-INFRINGEMENT OF THIRD PARTY INTELLECTUAL PROPERTY RIGHTS.

These resources are intended for skilled developers designing with TI products. You are solely responsible for (1) selecting the appropriate TI products for your application, (2) designing, validating and testing your application, and (3) ensuring your application meets applicable standards, and any other safety, security, regulatory or other requirements.

These resources are subject to change without notice. TI grants you permission to use these resources only for development of an application that uses the TI products described in the resource. Other reproduction and display of these resources is prohibited. No license is granted to any other TI intellectual property right or to any third party intellectual property right. TI disclaims responsibility for, and you fully indemnify TI and its representatives against any claims, damages, costs, losses, and liabilities arising out of your use of these resources.

TI's products are provided subject to [TI's Terms of Sale](#), [TI's General Quality Guidelines](#), or other applicable terms available either on [ti.com](#) or provided in conjunction with such TI products. TI's provision of these resources does not expand or otherwise alter TI's applicable warranties or warranty disclaimers for TI products. Unless TI explicitly designates a product as custom or customer-specified, TI products are standard, catalog, general purpose devices.

TI objects to and rejects any additional or different terms you may propose.

Copyright © 2026, Texas Instruments Incorporated

Last updated 10/2025