

TPS382x-xx-Q1 Voltage Monitor With Watchdog Timer

1 Features

- Qualified for automotive applications
- AEC-Q100 Qualified With the Following Results:
 - Device temperature grade 1: -40°C to 125°C
 - Device HBM ESD classification level 2
 - Device CDM ESD classification level C4B
- ESD protection exceeds 2000V Per MIL-STD-883, Method 3015; using human body model ($C = 100\text{pF}$, $R = 1500\Omega$)
- Power-on reset generator with fixed delay time of 200ms (TPS3823/4/5/8-xx-Q1) or 25ms (TPS3820-xx-Q1)
- Manual reset input (TPS3820/3/5/8-xx-Q1)
- Reset output available in active-low (TPS3820/3/4/5-xx-Q1), Active-High (TPS3824/5-xx-Q1), and open drain (TPS3828-xx-Q1)
- Supply voltage supervision range: 2.5V, 3V, 3.3V, 5V
- Watchdog timer (TPS3820/3/4/8-xx-Q1)
- Supply current of $15\mu\text{A}$ (typical)
- 5-Pin SOT-23 package
- Temperature range: -40°C to 125°C

2 Applications

- Automotive DSPs, microcontrollers, or microprocessors
- Industrial equipment
- Programmable controls
- Automotive systems
- Portable and battery-powered equipment
- Intelligent instruments
- Wireless communications systems

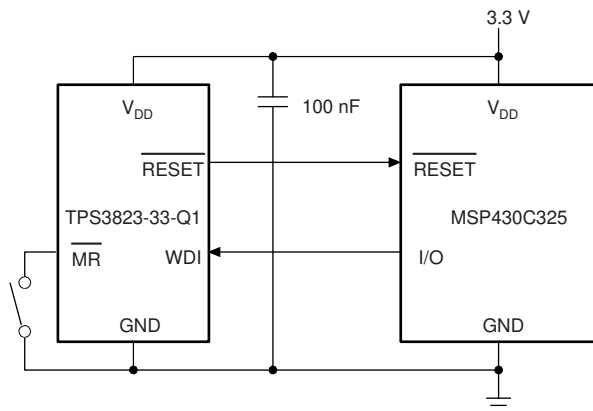

Typical Application Schematic

3 Description

For all new designs with TPS3820-xx-Q1, use the TPS3820-xxQPDBVRQ1 part number. The TPS3820-xxQP is functionally equivalent and a replacement to the TPS3820xxQ. The TPS3820-xxQDBVRQ1 is not recommended for new designs (NRND).

The TPS382x-xx-Q1 family of supervisors provide circuit initialization and timing supervision, primarily for DSP and processor-based systems. During power on, $\overline{\text{RESET}}$ asserts when the supply voltage V_{DD} becomes greater than 1.1V. Thereafter, the supply voltage supervisor monitors V_{DD} and keeps $\overline{\text{RESET}}$ active low as long as V_{DD} remains below the threshold voltage, $V_{\text{IT-}}$. An internal timer delays the return of the output to the inactive state (high) to verify a proper system reset. The delay time, t_d , starts after V_{DD} has risen above the threshold voltage $V_{\text{IT-}}$. When the supply voltage drops below the threshold voltage $V_{\text{IT-}}$, the output becomes active (low) again. No external components are required. All the devices of this family have a fixed-sense threshold voltage, $V_{\text{IT-}}$, set by an internal voltage divider. The TPS382x-xx-Q1 family also offers watchdog time out options of 200ms (TPS3820-xx-Q1) and 1.6s (TPS3823/4/8-xx-Q1).

Device Information

| PART NUMBER | PACKAGE (1) | BODY SIZE (NOM) (2) |
|---------------|-------------|---------------------|
| TPS382x-xx-Q1 | SOT-23 (5) | 2.90mm × 1.60mm |

- (1) For all available packages, see the orderable addendum at the end of the data sheet.
- (2) The package size (length × width) is a nominal value and includes pins, where applicable.

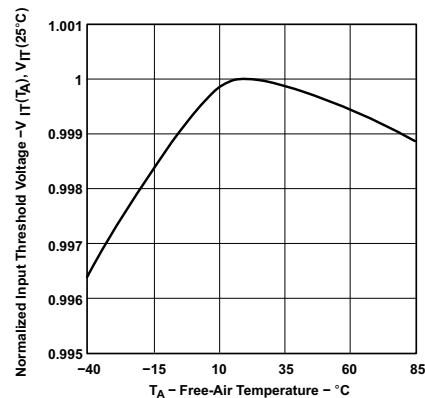

Normalized Input Threshold Voltage vs Free-Air Temperature



Table of Contents

| | | | |
|--|----|--|----|
| 1 Features | 1 | 7.2 Functional Block Diagram..... | 10 |
| 2 Applications | 1 | 7.3 Feature Description..... | 10 |
| 3 Description | 1 | 7.4 Device Functional Modes..... | 11 |
| 4 Device Comparison Table | 3 | 8 Application and Implementation | 12 |
| 5 Pin Configuration and Functions | 3 | 8.1 Application Information..... | 12 |
| Pin Functions..... | 3 | 8.2 Typical Applications..... | 12 |
| 6 Specifications | 4 | 8.3 Power Supply Recommendations..... | 13 |
| 6.1 Absolute Maximum Ratings..... | 4 | 8.4 Layout..... | 14 |
| 6.2 ESD Ratings..... | 4 | 9 Device and Documentation Support | 15 |
| 6.3 Recommended Operating Conditions..... | 4 | 9.1 Documentation Support..... | 15 |
| 6.4 Thermal Information..... | 4 | 9.2 Receiving Notification of Documentation Updates.... | 15 |
| 6.5 Electrical Characteristics..... | 5 | 9.3 Support Resources..... | 15 |
| 6.6 Timing Requirements..... | 7 | 9.4 Trademarks..... | 15 |
| 6.7 Switching Characteristics..... | 7 | 9.5 Electrostatic Discharge Caution..... | 15 |
| 6.8 Timing Diagram..... | 7 | 9.6 Glossary..... | 15 |
| 6.9 Typical Characteristics..... | 8 | 10 Revision History | 15 |
| 7 Detailed Description | 10 | 11 Mechanical, Packaging, and Orderable Information | 16 |
| 7.1 Overview..... | 10 | | |

4 Device Comparison Table

| DEVICE | RESET | RESET | WDI | MR | FIXED DELAY TIME |
|---------------|-----------|------------|-----|----|------------------|
| TPS3820-xx-Q1 | | Push-pull | X | X | 25ms |
| TPS3823-xx-Q1 | | Push-pull | X | X | 200ms |
| TPS3824-xx-Q1 | Push-pull | | X | | 200ms |
| TPS3825-xx-Q1 | Push-pull | Push-pull | | X | 200ms |
| TPS3828-xx-Q1 | | Open-drain | X | X | 200ms |

5 Pin Configuration and Functions



Figure 5-1. TPS3820-xx-Q1, TPS3823-xx-Q1, TPS3828-xx-Q1: DBV PACKAGE 5-Pin SOT-23 Top View



Figure 5-2. TPS3824-xx-Q1: DBV PACKAGE 5-Pin SOT-23 Top View

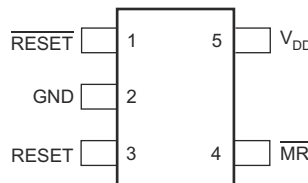

Figure 5-3. TPS3825-xx-Q1: DBV PACKAGE 5-Pin SOT-23 Top View

Pin Functions

| NAME | PIN | | | I/O | DESCRIPTION |
|-----------------|---|---------------|---------------|-----|---|
| | TPS3820-xx-Q1, TPS3823-xx-Q1, TPS3828-xx-Q1 | TPS3824-xx-Q1 | TPS3825-xx-Q1 | | |
| GND | 2 | 2 | 2 | — | Ground connection |
| MR | 3 | — | 4 | I | Manual-reset input. Pull low to force a reset. RESET remains low as long as MR is low and for the time-out period after MR goes high. Leave unconnected or connect to V _{DD} when unused. |
| RESET | — | 3 | 3 | O | Active-high reset output. Either push-pull or open-drain output stage. |
| RESET | 1 | 1 | 1 | O | Active-low reset output. Either push-pull or open-drain output stage. |
| V _{DD} | 5 | 5 | 5 | I | Supply voltage. Powers the device and monitors the voltage. |
| WDI | 4 | 4 | — | I | Watchdog timer input. If WDI remains high or low longer than the time-out period, then reset is triggered. The timer clears when reset is asserted or when WDI sees a falling edge. If left floating, the device generates pulses internally to prevent watchdog reset event. WDI must be driven low or high for watchdog error to assert output. |

6 Specifications

6.1 Absolute Maximum Ratings

over operating free-air temperature range (unless otherwise noted)⁽¹⁾

| | | MIN | MAX | UNIT |
|-------------|--|------|-----------------------|------|
| Voltage | VDD | -0.3 | 6 | V |
| | RESET, $\overline{\text{RESET}}$, $\overline{\text{MR}}$, WDI | -0.3 | $V_{\text{DD}} + 0.3$ | V |
| Current | Maximum low output, I_{OL} | -5 | 5 | mA |
| | Maximum high output, I_{OH} | -5 | 5 | mA |
| | Output range ($V_{\text{O}} < 0$ or $V_{\text{O}} > V_{\text{DD}}$), I_{OK} | -10 | 10 | mA |
| Temperature | Operating free-air temperature, T_{A} | -40 | 125 | °C |
| | Storage temperature range, T_{stg} | -65 | 150 | °C |

- (1) Stresses beyond those listed under Absolute Maximum Ratings may cause permanent damage to the device. These are stress ratings only, and functional operation of the device at these or any other conditions beyond those indicated under Recommended Operating Conditions is not implied. Exposure to absolute-maximum-rated conditions for extended periods may affect device reliability.

6.2 ESD Ratings

| | | | VALUE | UNIT |
|--------------------|-------------------------|--|-------|------|
| $V_{\text{(ESD)}}$ | Electrostatic discharge | Human-body model (HBM), per ANSI/ESDA/JEDEC JS-001 ⁽¹⁾ | ±2000 | V |
| | | Charged-device model (CDM), per JEDEC specification JESD22-C101 ⁽²⁾ | ±750 | |

- (1) JEDEC document JEP155 states that 500V HBM allows safe manufacturing with a standard ESD control process
 (2) JEDEC document JEP157 states that 250V CDM allows safe manufacturing with a standard ESD control process.

6.3 Recommended Operating Conditions

over operating free-air temperature range (unless otherwise noted)

| | | MIN | NOM | MAX | UNIT |
|---------------------|--|----------------------------|-----|----------------------------|------|
| V_{DD} | Supply voltage | 1.1 | | 5.5 | V |
| V_{I} | Input voltage | 0 | | $V_{\text{DD}} + 0.3$ | V |
| V_{IH} | High level input voltage at $\overline{\text{MR}}$ and WDI | $0.7 \times V_{\text{DD}}$ | | | V |
| V_{IL} | Low level input voltage | | | $0.3 \times V_{\text{DD}}$ | V |
| $\Delta t/\Delta V$ | Input transition rise and fall rate at $\overline{\text{MR}}$ or WDI | | | 100 | ns/V |
| T_{A} | Operating free-air temperature range | -40 | | 125 | °C |

6.4 Thermal Information

| THERMAL METRIC ⁽¹⁾ | | TPS382x-xx-Q1 |
|-------------------------------|--|---------------|
| | | DBV (SOT-23) |
| | | 5 PINS |
| $R_{\theta\text{JA}}$ | Junction-to-ambient thermal resistance | 185 |
| $R_{\theta\text{JC(top)}}$ | Junction-to-case (top) thermal resistance | 83.3 |
| $R_{\theta\text{JB}}$ | Junction-to-board thermal resistance | 52.4 |
| Ψ_{JT} | Junction-to-top characterization parameter | 20.4 |
| Ψ_{JB} | Junction-to-board characterization parameter | 52.0 |
| $R_{\theta\text{JC(bot)}}$ | Junction-to-case (bottom) thermal resistance | n/a |

- (1) For more information about traditional and new thermal metrics, see the [Semiconductor and IC Package Thermal Metrics](#) application report.

6.5 Electrical Characteristics

over operating temperature range (unless otherwise noted).

| PARAMETER | | TEST CONDITIONS | | MIN | NOM | MAX | UNIT | | | |
|---------------------|---|-----------------|---|--|-----------------------|---------------------------------|------|------|------|------|
| V _{OH} | High-level output voltage | RESET | TPS382x-25-Q1 | V _{DD} = V _{IT-} + 0.2V, I _{OH} = –20µA | 0.8 × V _{DD} | V _{DD} – 1.5V | V | | | |
| | | | TPS382x-30-Q1 | | | | | | | |
| | | | TPS382x-33-Q1 | | | | | | | |
| | | | TPS382x-50-Q1 | | | | | | | |
| | | RESET | TPS3824-25-Q1 TPS3825-25-Q1 | V _{DD} ≥ 1.8V, I _{OH} = –100µA | 0.8 × V _{DD} | V _{DD} – 1.5V | | V | | |
| | | | TPS3824-30-Q1 TPS3825-30-Q1 | | | | | | | |
| | | | TPS3824-33-Q1 TPS3825-33-Q1 | | | | | | | |
| | | | TPS3824-50-Q1 TPS3825-50-Q1 | | | | | | | |
| V _{OL} | Low-level output voltage | RESET | TPS3824-25-Q1 TPS3825-25-Q1 | V _{DD} = V _{IT-} + 0.2V, I _{OL} = 1mA | 0.4 | V | | | | |
| | | | TPS3824-30-Q1 TPS3825-30-Q1 | | | | | | | |
| | | | TPS3824-33-Q1 TPS3825-33-Q1 | | | | | | | |
| | | | TPS3824-50-Q1 TPS3825-50-Q1 | | | | | | | |
| | | RESET | TPS382x-25-Q1 | V _{DD} = V _{IT-} – 0.2V, I _{OL} = 1mA | 0.45 | V | | | | |
| | | | TPS382x-30-Q1 | | | | | | | |
| | | | TPS382x-33-Q1 | | | | | | | |
| | | | TPS382x-50-Q1 | | | | | | | |
| V _{POR} | Power-up reset voltage ⁽¹⁾ | | V _{OL(max)} = 0.4V, I _{OL(Sink)} = 20µA | | | 0.9 | V | | | |
| V _{IT-} | Negative-going input threshold voltage ⁽²⁾ | TPS382x-25-Q1 | TPS382x-30-Q1 | TPS382x-33-Q1 | TPS382x-50-Q1 | T _A = 0°C to 85°C | V | | | |
| | | | | | | | | 2.21 | 2.25 | 2.3 |
| | | | | | | | | 2.59 | 2.63 | 2.69 |
| | | | | | | | | 2.88 | 2.93 | 3 |
| | | 4.49 | 4.55 | 4.64 | | | | | | |
| | | TPS382x-25-Q1 | TPS382x-30-Q1 | TPS382x-33-Q1 | TPS382x-50-Q1 | T _A = –40°C to 125°C | V | | | |
| | | | | | | | | 2.19 | 2.25 | 2.3 |
| | | | | | | | | 2.55 | 2.63 | 2.69 |
| 2.84 | 2.93 | | | | | | | 3 | | |
| 4.44 | 4.55 | 4.64 | | | | | | | | |
| V _{HYS} | Hysteresis at V _{DD} input | TPS382x-25-Q1 | TPS382x-30-Q1 | TPS382x-33-Q1 | TPS382x-50-Q1 | | | | | |
| | | | | 30 | | | | | | |
| | | | | 50 | | | | | | |
| | | | | | | | | | | |
| I _{IH(AV)} | Average high-level input current | WDI | WDI = V _{DD} , time average (DC = 88%) | | 120 | | µA | | | |
| I _{IL(AV)} | Average low-level input current | | WDI = 0.3V, V _{DD} = 5.5V, time average (DC = 12%) | | –15 | | µA | | | |
| I _{IH} | High-level input current | WDI | WDI = V _{DD} | | 140 | 190 | µA | | | |
| | | MR | MR = 0.7 × V _{DD} , V _{DD} = 5.5V | | –40 | –60 | µA | | | |
| I _{IL} | Low-level input current | WDI | WDI = 0.3V, V _{DD} = 5.5V | | 140 | 190 | µA | | | |
| | | MR | MR = 0.3V, V _{DD} = 5.5V | | –110 | –160 | µA | | | |
| I _{OS} | Output short-circuit current ⁽³⁾ | RESET | TPS382x-25-Q1 | V _{DD} = V _{IT-,max} + 0.2V, V _O = 0V | | –400 | µA | | | |
| | | | TPS382x-30-Q1 | | | | | | | |
| | | | TPS382x-33-Q1 | | | | | | | |
| | | | TPS382x-50-Q1 | | | | | | | |
| | | | | | | –800 | | | | |

6.5 Electrical Characteristics (continued)

over operating temperature range (unless otherwise noted).

| | PARAMETER | TEST CONDITIONS | MIN | NOM | MAX | UNIT |
|----------|---|--|-----|-----|-----|------------------|
| I_{DD} | Supply current | WDI, \overline{MR} and outputs unconnected | | 15 | 25 | μA |
| R_{MR} | Internal pullup resistor at \overline{MR} | | | 90 | | $\text{k}\Omega$ |
| C_i | Input capacitance at \overline{MR} , WDI | $V_i = 0\text{V to } 5.5\text{V}$ | | 5 | | pF |

- (1) The lowest supply voltage at which $\overline{\text{RESET}}$ becomes active. $t_r, V_{DD} \geq 15\mu\text{s/V}$.
- (2) To make sure best stability of the threshold voltage, place a bypass capacitor (ceramic, $0.1\mu\text{F}$) near the supply terminal.
- (3) The $\overline{\text{RESET}}$ short-circuit current is the maximum pullup current when $\overline{\text{RESET}}$ is driven low by a microprocessor bidirectional reset pin.

6.6 Timing Requirements

at $R_L = 1M\Omega$, $C_L = 50pF$ and $T_J = 25^\circ C$, unless otherwise noted.

| PARAMETER | | TEST CONDITIONS | MIN | NOM | MAX | UNIT | |
|-----------|-------------|--------------------|--|-----|-----|------|---------|
| t_W | Pulse width | At V_{DD} | $V_{DD} = V_{IT-} + 0.2V, V_{DD} = V_{IT-} - 0.2V$ | | | 6 | μs |
| | | At \overline{MR} | $V_{DD} \geq V_{IT-} + 0.2V, V_{IL} = 0.3 \times V_{DD}, V_{IH} = 0.7 \times V_{DD}$ | | | 1 | μs |
| | | At WDI | | | | 100 | ns |

6.7 Switching Characteristics

at $R_L = 1M\Omega$, $C_L = 50pF$ and $T_J = 25^\circ C$, unless otherwise noted.

| PARAMETER | | TEST CONDITIONS | MIN | NOM | MAX | UNIT | | | |
|-----------|--|--|--|-----|-----|--|-----|-----|---------|
| t_{out} | Watchdog time out | TPS3820-xx-Q1 | $V_{DD} \geq V_{IT-} + 0.2V$, See timing diagram | | | 112 | 200 | 300 | ms |
| | | TPS3823/4/8-xx-Q1 | | | | 0.9 | 1.6 | 2.5 | s |
| t_d | Delay time | TPS3820-xx-Q1 | $V_{DD} \geq V_{IT-} + 0.2V$, See timing diagram | | | 15 | 25 | 37 | ms |
| | | TPS3823/4/5/8-xx-Q1 | | | | 120 | 200 | 300 | |
| t_{PHL} | Propagation delay time, high-to-low output | \overline{MR} to RESET delay (TPS3820/3/5/8-xx-Q1) | $V_{DD} \geq V_{IT-} + 0.2V, V_{IL} = 0.3 \times V_{DD}, V_{IH} = 0.7 \times V_{DD}$ | | | | | 0.1 | μs |
| | | V_{DD} to RESET delay | | | | $V_{IL} = V_{IT-} - 0.2V, V_{IH} = V_{IT-} + 0.2V$ | | 25 | μs |
| t_{PLH} | Propagation delay time, low-to-high output | \overline{MR} to RESET delay (TPS3824/5-xx-Q1) | $V_{DD} \geq V_{IT-} + 0.2V, V_{IL} = 0.3 \times V_{DD}, V_{IH} = 0.7 \times V_{DD}$ | | | | | 0.1 | μs |
| | | V_{DD} to RESET delay (TPS3824/5-xx-Q1) | | | | $V_{IL} = V_{IT-} - 0.2V, V_{IH} = V_{IT-} + 0.2V$ | | 25 | μs |

6.8 Timing Diagram



Figure 6-1. Delay and Time Out Timing Diagram

6.9 Typical Characteristics



Figure 6-2. Normalized Input Threshold Voltage vs Free-Air Temperature at V_{DD}

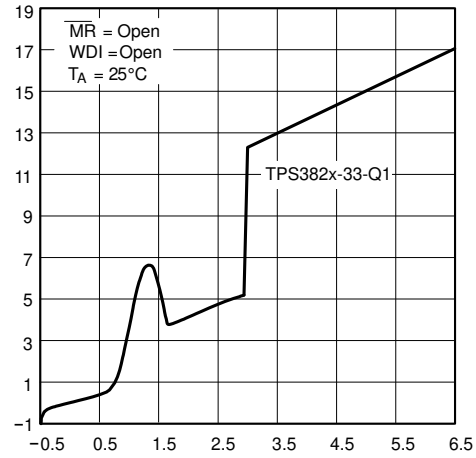

Figure 6-3. Supply Current vs Supply Voltage

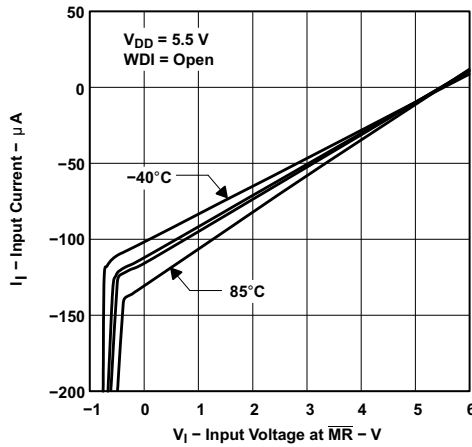

Figure 6-4. Input Current vs Input Voltage at \overline{MR}

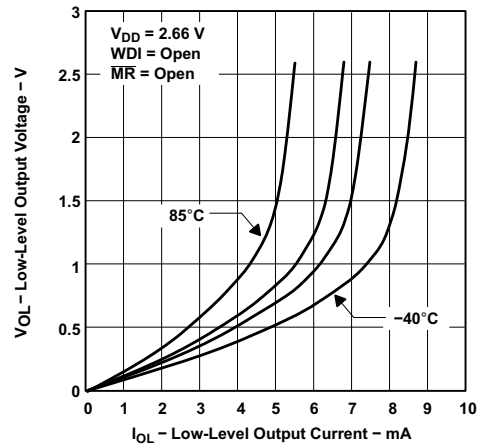

Figure 6-5. Low-Level Output Voltage vs Low-Level Output Current



Figure 6-6. High-Level Output Voltage vs High-Level Output Current

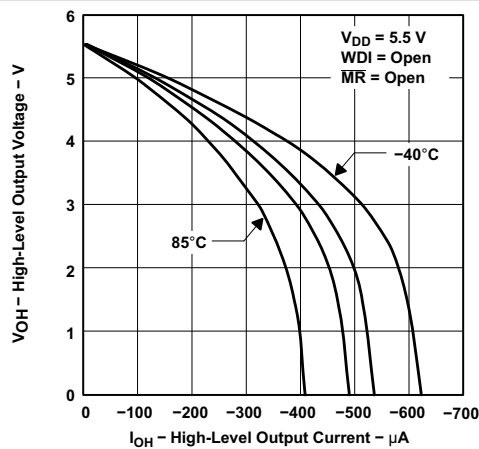

Figure 6-7. High-Level Output Voltage vs High-Level Output Current

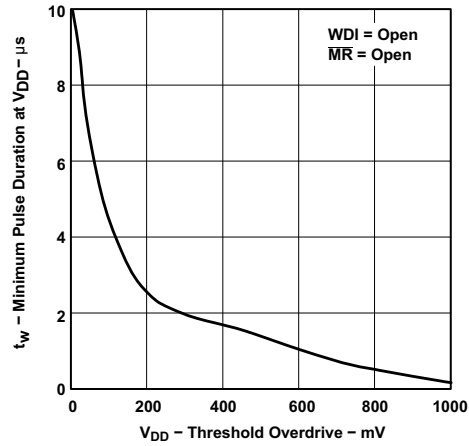

Figure 6-8. Minimum Pulse Duration at V_{DD} vs V_{DD} Threshold Overdrive

7 Detailed Description

7.1 Overview

The TPS382x-xx-Q1 family of supervisors provide circuit initialization and timing supervision. Optional configurations include devices with active-high and active-low output signals (TPS3824/5-xx-Q1), devices with a watchdog timer (TPS3820/3/4/8-xx-Q1), and devices with manual reset (\overline{MR}) pins (TPS3820/3/5/8-xx-Q1). \overline{RESET} asserts when the supply voltage, V_{DD} , rises above 1.1V. For devices with active-low output logic, the device monitors V_{DD} and keeps \overline{RESET} low as long as V_{DD} remains below the negative threshold voltage, V_{IT-} . For devices with active-high output logic, $RESET$ remains high as long as V_{DD} remains below V_{IT-} . An internal timer delays the return of the output to the inactive state (high) to make sure proper system reset. The delay time, t_d , starts after V_{DD} rises above the positive threshold voltage ($V_{IT-} + V_{HYS}$). When the supply voltage drops below V_{IT-} , the output becomes active (low) again. All the devices of this family have a fixed-sense threshold voltage, V_{IT-} , set by an internal voltage divider, so no external components are required.

The TPS382x-xx-Q1 family is designed to monitor supply voltages of 2.5V, 3V, 3.3V, and 5V. The devices are available in a 5-pin SOT-23 package and are characterized for operation over a temperature range of -40°C to 125°C , and are qualified in accordance with AEC-Q100 stress test qualification for integrated circuits.

7.2 Functional Block Diagram



- A. TPS3824/5-xx-Q1
- B. TPS3820/3/5/8-xx-Q1
- C. TPS3820/3/4/8-xx-Q1

7.3 Feature Description

7.3.1 Manual Reset (\overline{MR})

The \overline{MR} input allows an external logic signal from processors, logic circuits, and/or discrete sensors to force a reset signal regardless of V_{DD} with respect to V_{IT-} or the state of the watchdog timer. A low level at \overline{MR} causes the reset signals to become active.

7.3.2 Active High or Active Low Output

All TPS382x-xx-Q1 devices have an active-low logic output (\overline{RESET}), while the TPS3824/5-xx-Q1 devices also include an active-high logic output ($RESET$).

7.3.3 Push-Pull or Open-Drain Output

All TPS382x-xx-Q1 devices, except for TPS3828-xx-Q1, have push-pull outputs. TPS3828-xx-Q1 devices have an open-drain output.

7.3.4 Watchdog Timer (WDI)

TPS3820/3/4/8-xx-Q1 devices have a watchdog timer that must be periodically triggered by negative transition at WDI to avoid a reset signal being issued. When the supervising system fails to retrigger the watchdog circuit within the time-out interval, t_{out} , $\overline{\text{RESET}}$ becomes active for the time period t_d . This event also reinitializes the watchdog timer.

The watchdog timer can be disabled by disconnecting the WDI pin from the system. If the WDI pin detects a high-impedance state the TPS3820/3/4/8-xx-Q1 generates a WDI pulse to make sure that $\overline{\text{RESET}}$ does not assert. If this behavior is not desired place a 1k Ω resistor from WDI to ground. This resistor makes sure that the TPS3820/3/4/8-xx-Q1 detects that WDI is not in a high-impedance state.

In applications where the input to the WDI pin is active (transitioning high and low) when the TPS3820/3/4/8-xx-Q1 is asserting $\overline{\text{RESET}}$, $\overline{\text{RESET}}$ is stuck at a logic low after the input voltage returns above V_{IT-} . If the application requires that input to WDI be active when the reset signal is asserted, then use a FET to decouple the WDI signal. An external FET decouples the WDI signal by disconnecting the WDI input when $\overline{\text{RESET}}$ is asserted. For more details on this, see [Section 8.2.2](#) for more details.

7.4 Device Functional Modes

The device functions according to the inputs and outputs in [Table 7-1](#).

Table 7-1. Function Table

| INPUTS | | OUTPUTS | |
|---------------------------------------|-------------------|---------------------------|--|
| $\overline{\text{MR}}$ ⁽¹⁾ | $V_{DD} > V_{IT}$ | $\overline{\text{RESET}}$ | $\overline{\text{RESET}}$ ⁽²⁾ |
| L | 0 | L | H |
| L | 1 | L | H |
| H | 0 | L | H |
| H | 1 | H | L |

(1) TPS3820/3/5/8-xx-Q1

(2) TPS3824/5-xx-Q1

8 Application and Implementation

Note

Information in the following applications sections is not part of the TI component specification, and TI does not warrant its accuracy or completeness. TI's customers are responsible for determining suitability of components for their purposes, as well as validating and testing their design implementation to confirm system functionality.

8.1 Application Information

The TPS382x-xx-Q1 family of devices are very small supervisory circuits that monitor fixed supply voltages of 2.5V, 3V, 3.3V, and 5V. The TPS382x-xx-Q1 family operates from 1.1V to 5.5V. Orderable options include versions with either push-pull or open-drain outputs, versions that use active-high or active-low logic for output signals, versions with a manual reset pin, and versions with a watchdog timer. See the [Section 4](#) for an overview of device options.

8.2 Typical Applications

8.2.1 Supply Rail Monitoring with Watchdog Time-out and 200ms Delay

The TPS3823-xx-Q1 can be used to monitor the supply rail for devices such as microcontrollers. The downstream device is enabled by the TPS3823-xx-Q1 once the voltage on the supply pin (V_{DD}) is above the internal threshold voltage ($V_{IT-} + V_{HYS}$). The downstream device is disabled by the TPS3823-xx-Q1 when V_{DD} falls below the threshold voltage minus the hysteresis voltage (V_{IT-}). The TPS3823-xx-Q1 also issues a reset signal if the WDI input is not periodically triggered by a positive or negative transition at WDI. When the supervising system fails to retrigger the watchdog circuit within the time-out interval, t_{out} , \overline{RESET} becomes active for the time period t_d .

Some applications require a shorter reset signal than the 200ms that most of the TPS382x-xx-Q1 family provide. In these cases, the TPS3820-xx-Q1 is a good choice because the device has a delay time of only 25ms. If an open-drain output is needed, replace the TPS3823-xx-Q1 with the TPS3828-xx-Q1 (if the WDI input must be active while \overline{RESET} is low, see [Section 8.2.2](#)). [Figure 8-1](#) shows the TPS3823-33-Q1 in a typical application.

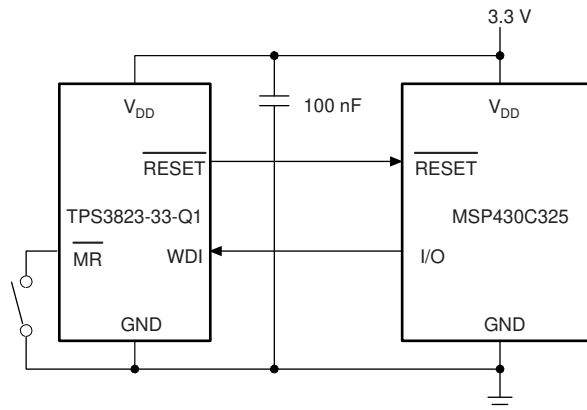

Figure 8-1. Supply Rail Monitoring With Watchdog Time-out

8.2.1.1 Design Requirements

The TPS3823-33-Q1 must drive the enable pin of a MSP430C325 using a logic-high signal to signify that the supply voltage is above the minimum operating voltage of the device and monitor the I/O pin to determine if the microcontroller is operating correctly.

8.2.1.2 Detailed Design Procedure

Determine which version of the TPS382x-xx-Q1 family best works for the functional performance required. If the input supply is noisy, include an input capacitor to help avoid unwanted changes to the reset signal.

8.2.1.3 Application Curve

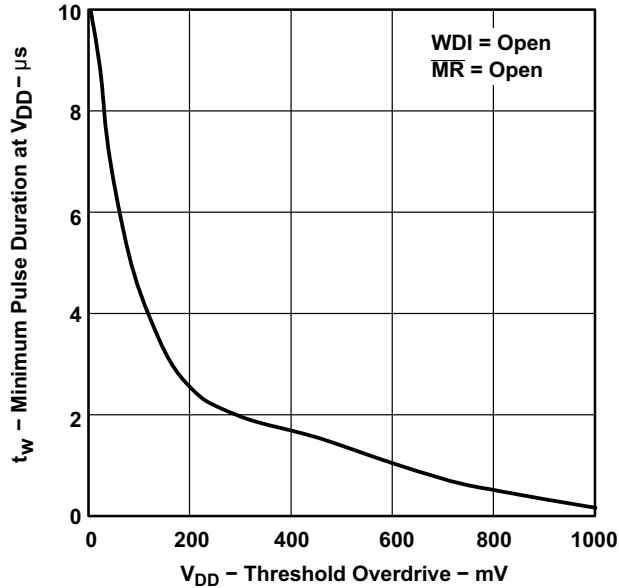

Figure 8-2. Minimum Pulse Duration at V_{DD} vs V_{DD} Threshold Overdrive

8.2.2 Decoupling WDI During Reset Event

If the application requires that the input to WDI is active when the reset signal is asserted, Figure 8-3 shows how to decouple WDI from the active signal using an N-channel FET. The N-channel FET is placed in series with the WDI pin, with the gate of the FET connected to the $\overline{\text{RESET}}$ output.

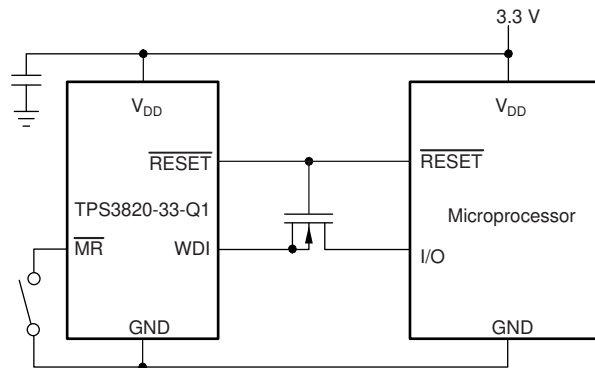

Figure 8-3. WDI Example

8.3 Power Supply Recommendations

These devices are designed to operate from an input supply with a voltage range from 1.1V to 5.5V. Though not required, good analog design is to place a 0.1μF ceramic capacitor close to the V_{DD} pin if the input supply is noisy.

8.4 Layout

8.4.1 Layout Guidelines

Follow these guidelines to lay out the printed-circuit-board (PCB) that is used for the TPS382x-xx-Q1 family of devices.

- Place the V_{DD} decoupling capacitor (C_{VDD}) close to the device.
- Avoid using long traces for the V_{DD} supply node. The V_{DD} capacitor (C_{VDD}), along with parasitic inductance from the supply to the capacitor, can form an LC tank and create ringing with peak voltages above the maximum V_{DD} voltage.

8.4.2 Layout Example



Figure 8-4. Example Layout (DBV Package)

9 Device and Documentation Support

9.1 Documentation Support

9.1.1 Related Documentation

- [Latching a Voltage Supervisor \(Reset IC\)](#)
- [Voltage Supervisors \(Reset ICs\): Frequently Asked Questions \(FAQs\)](#)
- [Disabling the Watchdog Timer for TI's Family of Supervisors](#)

9.1.1.1 Related Links

The table below lists quick access links. Categories include technical documents, support and community resources, tools and software, and quick access to order now.

Table 9-1. Related Links

| PARTS | PRODUCT FOLDER | ORDER NOW | TECHNICAL DOCUMENTS | TOOLS & SOFTWARE | SUPPORT & COMMUNITY |
|------------|----------------------------|----------------------------|----------------------------|----------------------------|----------------------------|
| TPS3820-Q1 | Click here | Click here | Click here | Click here | Click here |
| TPS3823-Q1 | Click here | Click here | Click here | Click here | Click here |
| TPS3824-Q1 | Click here | Click here | Click here | Click here | Click here |
| TPS3825-Q1 | Click here | Click here | Click here | Click here | Click here |
| TPS3828-Q1 | Click here | Click here | Click here | Click here | Click here |

9.2 Receiving Notification of Documentation Updates

To receive notification of documentation updates, navigate to the device product folder on [ti.com](#). Click on *Notifications* to register and receive a weekly digest of any product information that has changed. For change details, review the revision history included in any revised document.

9.3 Support Resources

[TI E2E™ support forums](#) are an engineer's go-to source for fast, verified answers and design help — straight from the experts. Search existing answers or ask your own question to get the quick design help you need.

Linked content is provided "AS IS" by the respective contributors. They do not constitute TI specifications and do not necessarily reflect TI's views; see TI's [Terms of Use](#).

9.4 Trademarks

TI E2E™ is a trademark of Texas Instruments.
All trademarks are the property of their respective owners.

9.5 Electrostatic Discharge Caution



This integrated circuit can be damaged by ESD. Texas Instruments recommends that all integrated circuits be handled with appropriate precautions. Failure to observe proper handling and installation procedures can cause damage.

ESD damage can range from subtle performance degradation to complete device failure. Precision integrated circuits may be more susceptible to damage because very small parametric changes could cause the device not to meet its published specifications.

9.6 Glossary

[TI Glossary](#) This glossary lists and explains terms, acronyms, and definitions.

10 Revision History

NOTE: Page numbers for previous revisions may differ from page numbers in the current version.

| Changes from Revision D (July 2019) to Revision E (March 2025) | Page |
|---|------|
| • Updated the numbering format for tables, figures, and cross-references throughout the document..... | 1 |

| | |
|---|---|
| • Updated the numbering format for tables, figures, and cross-references throughout the document..... | 1 |
| • Updated thermal parameters..... | 4 |
| • Clarify VPOR test conditions..... | 5 |
| • Updated MR resistance typical value..... | 5 |

| Changes from Revision C (December 2015) to Revision D (July 2019) | Page |
|--|-------------|
| • For all new designs, use the TPS3820-33QPDBVRQ1 and TPS3820-50QPDBVRQ1. TPS3820-xxQP is functionally equivalent and a replacement to the TPS3820xxQ..... | 1 |

| Changes from Revision B (June 2008) to Revision C (December 2015) | Page |
|--|-------------|
| • Added <i>ESD Ratings</i> table, <i>Feature Description</i> section, <i>Device Functional Modes, Application and Implementation</i> section, <i>Power Supply Recommendations</i> section, <i>Layout</i> section, <i>Device and Documentation Support</i> section, and <i>Mechanical, Packaging, and Orderable Information</i> section | 1 |
| • Added AEC-Q100 Qualified information and Temperature Range to <i>Features</i> | 1 |
| • Added -Q1 to all applicable part numbers | 1 |
| • Added FIXED DELAY TIME column to table | 3 |

11 Mechanical, Packaging, and Orderable Information

The following pages include mechanical, packaging, and orderable information. This information is the most current data available for the designated devices. This data is subject to change without notice and revision of this document. For browser-based versions of this data sheet, refer to the left-hand navigation.

PACKAGING INFORMATION

| Orderable part number | Status (1) | Material type (2) | Package Pins | Package qty Carrier | RoHS (3) | Lead finish/ Ball material (4) | MSL rating/ Peak reflow (5) | Op temp (°C) | Part marking (6) |
|------------------------------------|---------------|----------------------|------------------|-----------------------|-------------|--------------------------------------|-----------------------------------|--------------|---------------------|
| TPS3820-33QDBVRQ1 | NRND | Production | SOT-23 (DBV) 5 | 3000 LARGE T&R | Yes | NIPDAU | Level-1-260C-UNLIM | -40 to 125 | PDEQ |
| TPS3820-33QDBVRQ1.A | NRND | Production | SOT-23 (DBV) 5 | 3000 LARGE T&R | Yes | NIPDAU | Level-1-260C-UNLIM | -40 to 125 | PDEQ |
| TPS3820-33QPDBVRQ1 | Active | Production | SOT-23 (DBV) 5 | 3000 LARGE T&R | Yes | NIPDAU SN | Level-1-260C-UNLIM | -40 to 125 | 33PQ |
| TPS3820-33QPDBVRQ1.A | Active | Production | SOT-23 (DBV) 5 | 3000 LARGE T&R | Yes | NIPDAU | Level-1-260C-UNLIM | -40 to 125 | 33PQ |
| TPS3820-50QDBVRQ1 | NRND | Production | SOT-23 (DBV) 5 | 3000 LARGE T&R | Yes | NIPDAU | Level-1-260C-UNLIM | -40 to 125 | PDDQ |
| TPS3820-50QDBVRQ1.A | NRND | Production | SOT-23 (DBV) 5 | 3000 LARGE T&R | Yes | NIPDAU | Level-1-260C-UNLIM | -40 to 125 | PDDQ |
| TPS3820-50QPDBVRQ1 | Active | Production | SOT-23 (DBV) 5 | 3000 LARGE T&R | Yes | NIPDAU | Level-1-260C-UNLIM | -40 to 125 | 50PQ |
| TPS3820-50QPDBVRQ1.A | Active | Production | SOT-23 (DBV) 5 | 3000 LARGE T&R | Yes | NIPDAU | Level-1-260C-UNLIM | -40 to 125 | 50PQ |
| TPS3823-25QDBVRQ1 | Active | Production | SOT-23 (DBV) 5 | 3000 LARGE T&R | Yes | NIPDAU SN | Level-1-260C-UNLIM | -40 to 125 | PAPQ |
| TPS3823-25QDBVRQ1.A | Active | Production | SOT-23 (DBV) 5 | 3000 LARGE T&R | Yes | SN | Level-1-260C-UNLIM | -40 to 125 | PAPQ |
| TPS3823-33QDBVRQ1 | Active | Production | SOT-23 (DBV) 5 | 3000 LARGE T&R | Yes | NIPDAU SN | Level-1-260C-UNLIM | -40 to 125 | PARQ |
| TPS3823-33QDBVRQ1.A | Active | Production | SOT-23 (DBV) 5 | 3000 LARGE T&R | Yes | SN | Level-1-260C-UNLIM | -40 to 125 | PARQ |
| TPS3823-50QDBVRQ1 | Active | Production | SOT-23 (DBV) 5 | 3000 LARGE T&R | Yes | NIPDAU SN | Level-1-260C-UNLIM | -40 to 125 | PASQ |
| TPS3823-50QDBVRQ1.A | Active | Production | SOT-23 (DBV) 5 | 3000 LARGE T&R | Yes | SN | Level-1-260C-UNLIM | -40 to 125 | PASQ |
| TPS3824-33QDBVRQ1 | Active | Production | SOT-23 (DBV) 5 | 3000 LARGE T&R | Yes | NIPDAU | Level-1-260C-UNLIM | -40 to 125 | PAVQ |
| TPS3824-33QDBVRQ1.A | Active | Production | SOT-23 (DBV) 5 | 3000 LARGE T&R | Yes | NIPDAU | Level-1-260C-UNLIM | -40 to 125 | PAVQ |
| TPS3824-50QDBVRQ1 | Active | Production | SOT-23 (DBV) 5 | 3000 LARGE T&R | Yes | NIPDAU SN | Level-1-260C-UNLIM | -40 to 125 | PAWQ |
| TPS3824-50QDBVRQ1.A | Active | Production | SOT-23 (DBV) 5 | 3000 LARGE T&R | Yes | SN | Level-1-260C-UNLIM | -40 to 125 | PAWQ |
| TPS3825-33QDBVRQ1 | Active | Production | SOT-23 (DBV) 5 | 3000 LARGE T&R | Yes | NIPDAU SN | Level-1-260C-UNLIM | -40 to 125 | PDGQ |
| TPS3825-33QDBVRQ1.A | Active | Production | SOT-23 (DBV) 5 | 3000 LARGE T&R | Yes | SN | Level-1-260C-UNLIM | -40 to 125 | PDGQ |
| TPS3828-33QDBVRQ1 | Active | Production | SOT-23 (DBV) 5 | 3000 LARGE T&R | Yes | NIPDAU SN | Level-1-260C-UNLIM | -40 to 125 | PDIQ |
| TPS3828-33QDBVRQ1.A | Active | Production | SOT-23 (DBV) 5 | 3000 LARGE T&R | Yes | SN | Level-1-260C-UNLIM | -40 to 125 | PDIQ |
| TPS3828-50QDBVRG4Q | NRND | Production | SOT-23 (DBV) 5 | 3000 LARGE T&R | Yes | NIPDAU | Level-1-260C-UNLIM | -40 to 125 | PDHQ |

(1) **Status:** For more details on status, see our [product life cycle](#).

(2) **Material type:** When designated, preproduction parts are prototypes/experimental devices, and are not yet approved or released for full production. Testing and final process, including without limitation quality assurance, reliability performance testing, and/or process qualification, may not yet be complete, and this item is subject to further changes or possible discontinuation. If available for ordering, purchases will be subject to an additional waiver at checkout, and are intended for early internal evaluation purposes only. These items are sold without warranties of any kind.

(3) **RoHS values:** Yes, No, RoHS Exempt. See the [TI RoHS Statement](#) for additional information and value definition.

(4) **Lead finish/Ball material:** Parts may have multiple material finish options. Finish options are separated by a vertical ruled line. Lead finish/Ball material values may wrap to two lines if the finish value exceeds the maximum column width.

(5) **MSL rating/Peak reflow:** The moisture sensitivity level ratings and peak solder (reflow) temperatures. In the event that a part has multiple moisture sensitivity ratings, only the lowest level per JEDEC standards is shown. Refer to the shipping label for the actual reflow temperature that will be used to mount the part to the printed circuit board.

(6) **Part marking:** There may be an additional marking, which relates to the logo, the lot trace code information, or the environmental category of the part.

Multiple part markings will be inside parentheses. Only one part marking contained in parentheses and separated by a "~" will appear on a part. If a line is indented then it is a continuation of the previous line and the two combined represent the entire part marking for that device.

Important Information and Disclaimer: The information provided on this page represents TI's knowledge and belief as of the date that it is provided. TI bases its knowledge and belief on information provided by third parties, and makes no representation or warranty as to the accuracy of such information. Efforts are underway to better integrate information from third parties. TI has taken and continues to take reasonable steps to provide representative and accurate information but may not have conducted destructive testing or chemical analysis on incoming materials and chemicals. TI and TI suppliers consider certain information to be proprietary, and thus CAS numbers and other limited information may not be available for release.

In no event shall TI's liability arising out of such information exceed the total purchase price of the TI part(s) at issue in this document sold by TI to Customer on an annual basis.

OTHER QUALIFIED VERSIONS OF TPS3820-Q1, TPS3823-Q1, TPS3824-Q1, TPS3825-Q1, TPS3828-Q1 :

- Catalog : [TPS3820](#), [TPS3823](#), [TPS3824](#), [TPS3825](#), [TPS3828](#)

NOTE: Qualified Version Definitions:

- Catalog - TI's standard catalog product

TAPE AND REEL INFORMATION

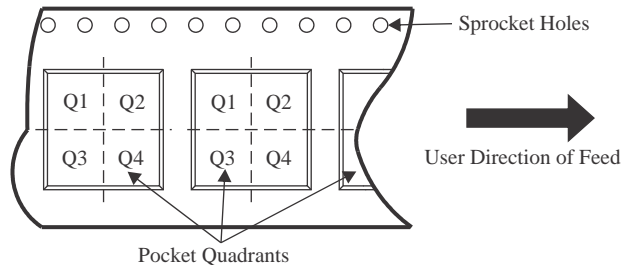
QUADRANT ASSIGNMENTS FOR PIN 1 ORIENTATION IN TAPE

*All dimensions are nominal

| Device | Package Type | Package Drawing | Pins | SPQ | Reel Diameter (mm) | Reel Width W1 (mm) | A0 (mm) | B0 (mm) | K0 (mm) | P1 (mm) | W (mm) | Pin1 Quadrant |
|--------------------|--------------|-----------------|------|------|--------------------|--------------------|---------|---------|---------|---------|--------|---------------|
| TPS3820-33QDBVRQ1 | SOT-23 | DBV | 5 | 3000 | 180.0 | 9.0 | 3.15 | 3.2 | 1.4 | 4.0 | 8.0 | Q3 |
| TPS3820-33QPDBVRQ1 | SOT-23 | DBV | 5 | 3000 | 180.0 | 8.4 | 3.2 | 3.2 | 1.4 | 4.0 | 8.0 | Q3 |
| TPS3820-33QPDBVRQ1 | SOT-23 | DBV | 5 | 3000 | 180.0 | 8.4 | 3.2 | 3.2 | 1.4 | 4.0 | 8.0 | Q3 |
| TPS3820-50QDBVRQ1 | SOT-23 | DBV | 5 | 3000 | 180.0 | 9.0 | 3.15 | 3.2 | 1.4 | 4.0 | 8.0 | Q3 |
| TPS3820-50QPDBVRQ1 | SOT-23 | DBV | 5 | 3000 | 180.0 | 8.4 | 3.2 | 3.2 | 1.4 | 4.0 | 8.0 | Q3 |
| TPS3820-50QPDBVRQ1 | SOT-23 | DBV | 5 | 3000 | 180.0 | 8.4 | 3.2 | 3.2 | 1.4 | 4.0 | 8.0 | Q3 |
| TPS3823-25QDBVRQ1 | SOT-23 | DBV | 5 | 3000 | 180.0 | 9.0 | 3.15 | 3.2 | 1.4 | 4.0 | 8.0 | Q3 |
| TPS3823-25QDBVRQ1 | SOT-23 | DBV | 5 | 3000 | 180.0 | 8.4 | 3.2 | 3.2 | 1.4 | 4.0 | 8.0 | Q3 |
| TPS3823-33QDBVRQ1 | SOT-23 | DBV | 5 | 3000 | 180.0 | 9.0 | 3.15 | 3.2 | 1.4 | 4.0 | 8.0 | Q3 |
| TPS3823-33QDBVRQ1 | SOT-23 | DBV | 5 | 3000 | 180.0 | 8.4 | 3.2 | 3.2 | 1.4 | 4.0 | 8.0 | Q3 |
| TPS3823-50QDBVRQ1 | SOT-23 | DBV | 5 | 3000 | 180.0 | 9.0 | 3.15 | 3.2 | 1.4 | 4.0 | 8.0 | Q3 |
| TPS3823-50QDBVRQ1 | SOT-23 | DBV | 5 | 3000 | 180.0 | 8.4 | 3.2 | 3.2 | 1.4 | 4.0 | 8.0 | Q3 |
| TPS3824-33QDBVRQ1 | SOT-23 | DBV | 5 | 3000 | 180.0 | 9.0 | 3.15 | 3.2 | 1.4 | 4.0 | 8.0 | Q3 |
| TPS3824-50QDBVRQ1 | SOT-23 | DBV | 5 | 3000 | 180.0 | 8.4 | 3.2 | 3.2 | 1.4 | 4.0 | 8.0 | Q3 |
| TPS3824-50QDBVRQ1 | SOT-23 | DBV | 5 | 3000 | 180.0 | 9.0 | 3.15 | 3.2 | 1.4 | 4.0 | 8.0 | Q3 |
| TPS3825-33QDBVRQ1 | SOT-23 | DBV | 5 | 3000 | 180.0 | 9.0 | 3.15 | 3.2 | 1.4 | 4.0 | 8.0 | Q3 |

| Device | Package Type | Package Drawing | Pins | SPQ | Reel Diameter (mm) | Reel Width W1 (mm) | A0 (mm) | B0 (mm) | K0 (mm) | P1 (mm) | W (mm) | Pin1 Quadrant |
|--------------------|--------------|-----------------|------|------|--------------------|--------------------|---------|---------|---------|---------|--------|---------------|
| TPS3828-33QDBVRQ1 | SOT-23 | DBV | 5 | 3000 | 180.0 | 9.0 | 3.15 | 3.2 | 1.4 | 4.0 | 8.0 | Q3 |
| TPS3828-33QDBVRQ1 | SOT-23 | DBV | 5 | 3000 | 180.0 | 8.4 | 3.2 | 3.2 | 1.4 | 4.0 | 8.0 | Q3 |
| TPS3828-50QDBVRG4Q | SOT-23 | DBV | 5 | 3000 | 180.0 | 9.0 | 3.15 | 3.2 | 1.4 | 4.0 | 8.0 | Q3 |

TAPE AND REEL BOX DIMENSIONS

*All dimensions are nominal

| Device | Package Type | Package Drawing | Pins | SPQ | Length (mm) | Width (mm) | Height (mm) |
|--------------------|--------------|-----------------|------|------|-------------|------------|-------------|
| TPS3820-33QDBVRQ1 | SOT-23 | DBV | 5 | 3000 | 182.0 | 182.0 | 20.0 |
| TPS3820-33QPDBVRQ1 | SOT-23 | DBV | 5 | 3000 | 210.0 | 185.0 | 35.0 |
| TPS3820-33QPDBVRQ1 | SOT-23 | DBV | 5 | 3000 | 210.0 | 185.0 | 35.0 |
| TPS3820-50QDBVRQ1 | SOT-23 | DBV | 5 | 3000 | 182.0 | 182.0 | 20.0 |
| TPS3820-50QPDBVRQ1 | SOT-23 | DBV | 5 | 3000 | 210.0 | 185.0 | 35.0 |
| TPS3820-50QPDBVRQ1 | SOT-23 | DBV | 5 | 3000 | 210.0 | 185.0 | 35.0 |
| TPS3823-25QDBVRQ1 | SOT-23 | DBV | 5 | 3000 | 182.0 | 182.0 | 20.0 |
| TPS3823-25QDBVRQ1 | SOT-23 | DBV | 5 | 3000 | 210.0 | 185.0 | 35.0 |
| TPS3823-33QDBVRQ1 | SOT-23 | DBV | 5 | 3000 | 182.0 | 182.0 | 20.0 |
| TPS3823-33QDBVRQ1 | SOT-23 | DBV | 5 | 3000 | 210.0 | 185.0 | 35.0 |
| TPS3823-50QDBVRQ1 | SOT-23 | DBV | 5 | 3000 | 182.0 | 182.0 | 20.0 |
| TPS3823-50QDBVRQ1 | SOT-23 | DBV | 5 | 3000 | 210.0 | 185.0 | 35.0 |
| TPS3824-33QDBVRQ1 | SOT-23 | DBV | 5 | 3000 | 182.0 | 182.0 | 20.0 |
| TPS3824-50QDBVRQ1 | SOT-23 | DBV | 5 | 3000 | 210.0 | 185.0 | 35.0 |
| TPS3824-50QDBVRQ1 | SOT-23 | DBV | 5 | 3000 | 182.0 | 182.0 | 20.0 |
| TPS3825-33QDBVRQ1 | SOT-23 | DBV | 5 | 3000 | 182.0 | 182.0 | 20.0 |
| TPS3828-33QDBVRQ1 | SOT-23 | DBV | 5 | 3000 | 182.0 | 182.0 | 20.0 |
| TPS3828-33QDBVRQ1 | SOT-23 | DBV | 5 | 3000 | 210.0 | 185.0 | 35.0 |

| Device | Package Type | Package Drawing | Pins | SPQ | Length (mm) | Width (mm) | Height (mm) |
|--------------------|--------------|-----------------|------|------|-------------|------------|-------------|
| TPS3828-50QDBVRG4Q | SOT-23 | DBV | 5 | 3000 | 182.0 | 182.0 | 20.0 |

EXAMPLE BOARD LAYOUT

DBV0005A

SOT-23 - 1.45 mm max height

SMALL OUTLINE TRANSISTOR



LAND PATTERN EXAMPLE
EXPOSED METAL SHOWN
SCALE:15X



SOLDER MASK DETAILS

4214839/K 08/2024

NOTES: (continued)

- 6. Publication IPC-7351 may have alternate designs.
- 7. Solder mask tolerances between and around signal pads can vary based on board fabrication site.

EXAMPLE STENCIL DESIGN

DBV0005A

SOT-23 - 1.45 mm max height

SMALL OUTLINE TRANSISTOR



SOLDER PASTE EXAMPLE
BASED ON 0.125 mm THICK STENCIL
SCALE:15X

4214839/K 08/2024

NOTES: (continued)

8. Laser cutting apertures with trapezoidal walls and rounded corners may offer better paste release. IPC-7525 may have alternate design recommendations.
9. Board assembly site may have different recommendations for stencil design.

IMPORTANT NOTICE AND DISCLAIMER

TI PROVIDES TECHNICAL AND RELIABILITY DATA (INCLUDING DATASHEETS), DESIGN RESOURCES (INCLUDING REFERENCE DESIGNS), APPLICATION OR OTHER DESIGN ADVICE, WEB TOOLS, SAFETY INFORMATION, AND OTHER RESOURCES "AS IS" AND WITH ALL FAULTS, AND DISCLAIMS ALL WARRANTIES, EXPRESS AND IMPLIED, INCLUDING WITHOUT LIMITATION ANY IMPLIED WARRANTIES OF MERCHANTABILITY, FITNESS FOR A PARTICULAR PURPOSE OR NON-INFRINGEMENT OF THIRD PARTY INTELLECTUAL PROPERTY RIGHTS.

These resources are intended for skilled developers designing with TI products. You are solely responsible for (1) selecting the appropriate TI products for your application, (2) designing, validating and testing your application, and (3) ensuring your application meets applicable standards, and any other safety, security, regulatory or other requirements.

These resources are subject to change without notice. TI grants you permission to use these resources only for development of an application that uses the TI products described in the resource. Other reproduction and display of these resources is prohibited. No license is granted to any other TI intellectual property right or to any third party intellectual property right. TI disclaims responsibility for, and you fully indemnify TI and its representatives against any claims, damages, costs, losses, and liabilities arising out of your use of these resources.

TI's products are provided subject to [TI's Terms of Sale](#), [TI's General Quality Guidelines](#), or other applicable terms available either on [ti.com](#) or provided in conjunction with such TI products. TI's provision of these resources does not expand or otherwise alter TI's applicable warranties or warranty disclaimers for TI products. Unless TI explicitly designates a product as custom or customer-specified, TI products are standard, catalog, general purpose devices.

TI objects to and rejects any additional or different terms you may propose.

Copyright © 2026, Texas Instruments Incorporated

Last updated 10/2025