

# TPS4HC120-Q1 120mΩ, 2A, Quad-Channel Automotive Smart High-Side Switch

## 1 Features

- Quad-channel 120mΩ automotive smart high-side switch with full diagnostics
  - Open-drain status output
  - Current sense analog output
- Wide operating voltage 3V to 28V
- Low power mode (LPM) with automatic entry and exit
  - $I_{Q,LPM} < 20\mu\text{A}/\text{ch}$  with all 4 channels ON and in LPM mode
- Ultra-low sleep current,  $<1\mu\text{A}$  at 25°C
- Selectable current limit, 0.25A to 5A
- Protection
  - Overload and short-circuit protection
  - Thermal shutdown and swing with self recovery
  - Inductive load negative voltage clamp
  - Loss-of-GND, loss-of-battery, and reverse battery protection
- Diagnostics
  - Global fault report for fast interrupt
  - Overcurrent and short-to-ground detection
  - Open-load and short-to-battery detection
- Qualified for automotive applications
  - AEC-Q100 qualified with the following results:
    - Device temperature grade 1:  $-40^\circ\text{C}$  to  $125^\circ\text{C}$  ambient operating temperature range
    - Electrical transient disturbance immunity certification of ISO7637-2 and ISO16750-2
- 28-pin thermally-enhanced HVSSOP package

## 2 Applications

- [ADAS modules](#)
- [Automotive display module](#)
- [Body control module](#)

## 3 Description

TPS4HC120-Q1 is an automotive quad-channel, smart high-side switch, with integrated NMOS power FET and charge pump, designed to meet the requirements of 12V automotive battery systems. The low RON (120mΩ) minimizes the device power dissipation when driving a wide range of output load current up to 2A when all four channels are enabled or 2.5A when only one channel is enabled.

The device integrates protection features such as thermal shutdown, output clamp, and current limit. These features improve system robustness during fault events such as short circuit. TPS4HC120-Q1 implements a selectable current limiting circuit that improves the reliability of the system by reducing inrush current when driving large capacitive loads and minimizing overload current. The device offers 10 selectable current limit settings (0.25A to 5A) based on the external resistor used on the ILIM pin. The device also provides an accurate load current sense that allows for improved load diagnostics such as overload and open-load detection, which enables better predictive maintenance.

TPS4HC120-Q1 is available in a 28-pin, 4.9mm × 7.1mm HVSSOP leaded package with 0.5mm pin pitch minimizing the PCB footprint.

### Package Information

| PART NUMBER  | PACKAGE <sup>(1)</sup> | PACKAGE SIZE <sup>(2)</sup> |
|--------------|------------------------|-----------------------------|
| TPS4HC120-Q1 | DGQ (HVSSOP, 28)       | 4.90mm × 7.10mm             |

(1) For all available packages, see the orderable addendum at the end of the data sheet.

(2) The package size (length × width) is a nominal value and includes pins, where applicable.

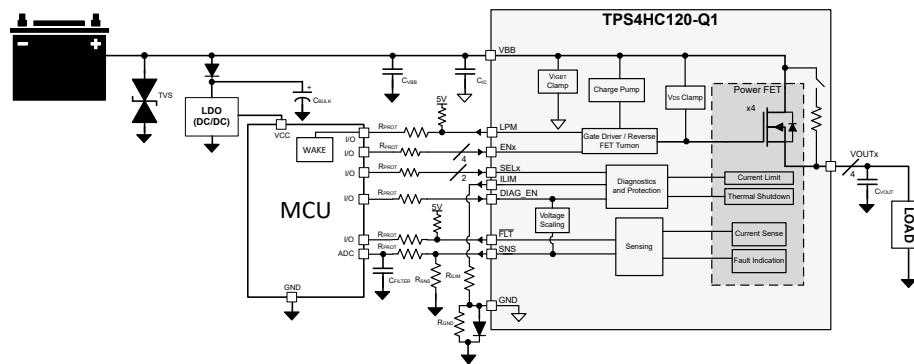

Typical Application Schematic

## Table of Contents

|  |    |  |    |
|--|----|--|----|
| <b>1 Features</b> .....                        | 1  | 7.3 Feature Description.....                                     | 15 |
| <b>2 Applications</b> .....                    | 1  | 7.4 Device Functional Modes.....                                 | 34 |
| <b>3 Description</b> .....                     | 1  | <b>8 Application and Implementation</b> .....                    | 37 |
| <b>4 Device Comparison Table</b> .....         | 3  | 8.1 Application Information.....                                 | 37 |
| <b>5 Pin Configuration and Functions</b> ..... | 4  | 8.2 Typical Application.....                                     | 37 |
| <b>6 Specifications</b> .....                  | 5  | 8.3 EMC Transient Disturbances Test.....                         | 38 |
| 6.1 Absolute Maximum Ratings.....              | 5  | 8.4 Power Supply Recommendations.....                            | 39 |
| 6.2 ESD Ratings.....                           | 5  | 8.5 Layout.....  | 39 |
| 6.3 Recommended Operating Conditions.....      | 5  | <b>9 Device and Documentation Support</b> .....                  | 42 |
| 6.4 Thermal Information.....                   | 6  | 9.1 Receiving Notification of Documentation Updates... 42        |    |
| 6.5 Electrical Characteristics.....            | 6  | 9.2 Support Resources.....                                       | 42 |
| 6.6 SNS Timing Characteristics.....            | 9  | 9.3 Trademarks.....  | 42 |
| 6.7 Switching Characteristics.....             | 10 | 9.4 Electrostatic Discharge Caution.....                         | 42 |
| 6.8 Typical Characteristics.....               | 11 | 9.5 Glossary.....  | 42 |
| <b>7 Detailed Description</b> .....            | 14 | <b>10 Revision History</b> .....                                 | 42 |
| 7.1 Overview.....                              | 14 | <b>11 Mechanical, Packaging, and Orderable Information</b> ..... | 42 |
| 7.2 Functional Block Diagram.....              | 14 |  |    |

## 4 Device Comparison Table

| PART NUMBER               | BEHAVIOR AFTER THERMAL FAULT  |
|---------------------------|---|
| TPS4HC120A                | LATCH off the faulted channel after thermal fault. Toggling EN is required to re-enable the specific channel. |
| TPS4HC120B <sup>(1)</sup> | Auto-retry after thermal fault.   |

(1) Device in preview. Please contact TI for more information.

## 5 Pin Configuration and Functions

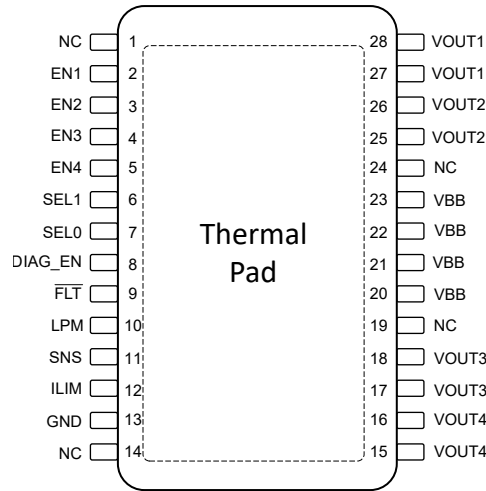

NC – No internal connection

Figure 5-1. DGQ Package, 28-Pin HVVSOP (Top View)

Table 5-1. Pin Functions

See Section 8 for full list of recommended components.

| PIN            |         | TYPE  | DESCRIPTION  |
|----------------|---------|-------|--|
| NO.            | NAME    |       |  |
| 1, 14, 19, 24  | NC      | N/A   | No internal connection.  |
| 2              | EN1     | I     | Input control for channel 1 activation, internal pulldown.   |
| 3              | EN2     | I     | Input control for channel 2 activation, internal pulldown.   |
| 4              | EN3     | I     | Input control for channel 3 activation, internal pulldown.   |
| 5              | EN4     | I     | Input control for channel 4 activation, internal pulldown.   |
| 6              | SEL1    | I     | SNS channel-selection high bit; internal pulldown.   |
| 7              | SEL0    | I     | SNS channel-selection low bit; internal pulldown.  |
| 8              | DIAG_EN | I     | Enable-disable pin for diagnostics, internal pulldown.   |
| 9              | FLT     | O     | Open drain global fault output. Referred to FAULT, FLT, or fault pin. Recommended 5-10kΩ pullup resistor.  |
| 10             | LPM     | O     | Open drain LPM status pin. Pulled high by external supply if the device is in LPM or SLEEP state. Pulled low internally when device is in ACTIVE mode. Recommended 5-10kΩ pullup resistor. |
| 11             | SNS     | O     | SNS current output.  |
| 12             | ILIM    | O     | Adjustable current limit. Connect a resistor to chip GND, SHORT the pin to chip GND, or leave the pin OPEN to set the current limit value.   |
| 13             | GND     | Power | Ground of device. Connect to resistor- diode ground network to have reverse battery protection.  |
| 15,16          | VOUT4   | Power | Output of channel 4 of the high side switch, connected to load.  |
| 17,18          | VOUT3   | Power | Output of channel 3 of the high side switch, connected to load.  |
| 20, 21, 22, 23 | VBB     | Power | Power supply.  |
| 25,26          | VOUT2   | Power | Output of channel 2 of the high side switch, connected to load.  |
| 27,28          | VOUT1   | Power | Output of channel 1 of the high side switch, connected to load.  |
| Thermal Pad    | Pad     | Power | Thermal Pad, internally shorted to ground.   |

## 6 Specifications

### 6.1 Absolute Maximum Ratings

Over operating free-air temperature range (unless otherwise noted)<sup>(1)</sup>

|   |  | MIN  | MAX | UNIT |
|---|--|------|-----|------|
| Maximum continuous supply voltage, $V_{BB}$                       |  |      | 28  | V    |
| Load dump voltage, $V_{LD}$                                       | ISO16750-2:2010(E)   |      | 35  | V    |
| Reverse Polarity Voltage  | Maximum duration of 3 minutes and with the application circuit | -18  |     | V    |
| Enable pin current, $I_{EN1}$ , $I_{EN2}$ , $I_{EN3}$ , $I_{EN4}$ |  | -0.5 | 20  | mA   |
| Enable pin voltage, $V_{EN1}$ , $V_{EN2}$ , $V_{EN3}$ , $V_{EN4}$ |  | -1.5 | 5.5 | V    |
| Diagnostic Enable pin current, $I_{DIA\_EN}$                      |  | -0.5 | 20  | mA   |
| Diagnostic Enable pin voltage, $V_{DIA\_EN}$                      |  | -1.5 | 5.5 | V    |
| Sense pin current, $I_{SNS}$                                      |  | -10  | 150 | mA   |
| Sense pin voltage, $V_{SNS}$                                      |  | -1.5 | 5.5 | V    |
| SELX pin current, $I_{SELX}$                                      |  | -0.5 | 20  | mA   |
| SELX pin voltage, $V_{SELX}$                                      |  | -1.5 | 5.5 | V    |
| FLT pin current, $I_{FLT}$  |  | -30  | 2.5 | mA   |
| FLT pin voltage, $V_{FLT}$  |  | -0.3 | 5.5 | V    |
| LPM pin current, $I_{LPM}$  |  | -30  | 2.5 | mA   |
| LPM pin voltage, $V_{LPM}$  |  | -0.3 | 5.5 | V    |
| ILIM pin current, $I_{ILIM}$                                      |  | -0.5 | 20  | mA   |
| ILIM pin voltage, $V_{ILIM}$                                      |  | -1.5 | 5.5 | V    |
| Reverse ground current, $I_{GND}$                                 | $V_{BB} < 0V$  | -50  |     | mA   |
| Maximum junction temperature, $T_J$                               |  |      | 150 | °C   |
| Storage temperature, $T_{stg}$                                    |  | -65  | 150 | °C   |

- (1) Operation outside the Absolute Maximum Ratings may cause permanent device damage. Absolute Maximum Ratings do not imply functional operation of the device at these or any other conditions beyond those listed under Recommended Operating Conditions. If used outside the Recommended Operating Conditions but within the Absolute Maximum Ratings, the device may not be fully functional, and this may affect device reliability, functionality, performance, and shorten the device lifetime.

### 6.2 ESD Ratings

|             |  |  | VALUE                        | UNIT  |   |
|-------------|--|--|------------------------------|-------|---|
| $V_{(ESD)}$ | Electrostatic discharge <sup>(1)</sup> | Human-body model (HBM), per AEC Q100-002 Classification Level 2 <sup>(2)</sup>   | All pins except VBB and VOUT | ±2000 | V |
|             |  | Human-body model (HBM), per AEC Q100-002 Classification Level H3A <sup>(2)</sup> | VBB and VOUT                 | ±4000 |   |
|             |  | Charged-device model (CDM), per AEC Q100-011 Classification Level C5             | All pins                     | ±750  |   |

- (1) All ESD strikes are with reference from the pin mentioned to GND  
(2) AEC-Q100-002 indicates that HBM stressing shall be in accordance with the ANSI/ESDA/JEDEC JS-001 specifications.

### 6.3 Recommended Operating Conditions

over operating free-air temperature range (unless otherwise noted) <sup>(1)</sup>Digital input pins are EN1, EN2, EN3, EN4, SEH, SEL, DIAG\_EN

|                |   | MIN | MAX | UNIT |
|----------------|---|-----|-----|------|
| $V_{VBB\_NOM}$ | Nominal supply voltage <sup>(1)</sup>   | 4   | 18  | V    |
| $V_{VBB\_EXT}$ | Extended supply voltage <sup>(2)</sup>  | 3   | 28  | V    |
| $V_{VBB\_SC}$  | Short circuit supply voltage capability |     | 28  | V    |
| $V_{DIN}$      | All digital input pin voltage           | -1  | 5.5 | V    |

### 6.3 Recommended Operating Conditions (continued)

over operating free-air temperature range (unless otherwise noted) <sup>(1)</sup>Digital input pins are EN1, EN2, EN3, EN4, SEH, SEL, DIAG\_EN

|                |                                | MIN | MAX | UNIT |
|----------------|--------------------------------|-----|-----|------|
| T <sub>A</sub> | Operating free-air temperature | -40 | 125 | °C   |

- (1) All operating voltage conditions are measured with respect to device GND  
(2) Device will function within extended operating range, however some parametric values might not apply.

### 6.4 Thermal Information

| THERMAL METRIC <sup>(1) (2)</sup> |  | TPS4HC120-Q1 | UNIT |
|-----------------------------------|--|--------------|------|
|                                   |  | DGQ (HVSSOP) |      |
|                                   |  | 28 PINS      |      |
| R <sub>θJA</sub>                  | Junction-to-ambient thermal resistance       | 32.1         | °C/W |
| R <sub>θJC(top)</sub>             | Junction-to-case (top) thermal resistance    | 32.4         | °C/W |
| R <sub>θJB</sub>                  | Junction-to-board thermal resistance         | 8.4          | °C/W |
| ψ <sub>JT</sub>                   | Junction-to-top characterization parameter   | 1.0          | °C/W |
| ψ <sub>JB</sub>                   | Junction-to-board characterization parameter | 8.3          | °C/W |
| R <sub>θJC(bot)</sub>             | Junction-to-case (bottom) thermal resistance | 2.1          | °C/W |

- (1) For more information about traditional and new thermal metrics, see the [SPRA953](#) application report.  
(2) The thermal parameters are based on a 4-layer PCB according to the JESD51-5 and JESD51-7 standards.

### 6.5 Electrical Characteristics

V<sub>BB</sub> = 6V to 18V, T<sub>A</sub> = -40°C to 125°C (unless otherwise noted); Typical application is 13.5V, 1A, RILIM = Open (unless otherwise specified). Digital input pins are EN1, EN2, EN3, EN4, SEL0, SEL1, DIAG\_EN.

| PARAMETER                        |   | TEST CONDITIONS  |  | MIN                    | TYP  | MAX  | UNIT |    |
|----------------------------------|---|--|--|------------------------|------|------|------|----|
| <b>INPUT VOLTAGE AND CURRENT</b> |   |  |  |                        |      |      |      |    |
| V <sub>UVLOR</sub>               | V <sub>BB</sub> undervoltage lockout rising                     | Measured with respect to the GND pin of the device   |  | 3.2                    | 3.6  | 4.0  | V    |    |
| V <sub>UVLOF</sub>               | V <sub>BB</sub> undervoltage lockout falling                    |  |  | 2.5                    | 2.75 | 3.0  | V    |    |
| V <sub>Clamp</sub>               | VDS clamp voltage   | T <sub>J</sub> = 25°C  |  | 35                     |      | 43   | V    |    |
|                                  |   | T <sub>J</sub> = -40°C to 150°C  |  | 34                     |      | 45   | V    |    |
| V <sub>OUT,Clamp</sub>           | VOUT clamp voltage  | T <sub>J</sub> = -40°C to 150°C  |  | -31                    |      | -23  | V    |    |
| I <sub>Q</sub>                   | Quiescent current all channels enabled                          | V <sub>BB</sub> ≤ 28V, V <sub>ENx</sub> = V <sub>DIAG_EN</sub> = 5V, I <sub>OUTx</sub> = 0A                              |  |                        | 3.8  | 4.5  | mA   |    |
| I <sub>Q,DIAG_DIS</sub>          | Quiescent current channel enabled diagnostic disabled           | V <sub>BB</sub> ≤ 28V<br>V <sub>EN</sub> = 5V V <sub>DIA_EN</sub> = 0V,<br>I <sub>OUTx</sub> = 0A                        | V <sub>BB</sub> ≤ 28 V<br>V <sub>EN</sub> = 5 V, V <sub>DIA_EN</sub> = 0 V,<br>I <sub>OUTx</sub> = 0 A |                        | 3.8  | 4.2  | mA   |    |
| I <sub>SB</sub>                  | Current consumption in standby mode                             | V <sub>BB</sub> ≤ 18V, I <sub>SNs</sub> = 0mA<br>V <sub>ENx</sub> = 0V, V <sub>DIAG_EN</sub> = 5V, V <sub>OUT</sub> = 0V |  |                        | 3.8  | 4.5  | mA   |    |
| t <sub>STBY</sub>                | Delay time to remain in standby mode before entering sleep mode | V <sub>ENx</sub> = V <sub>DIAG_EN</sub> = 5V to 0V   |  |                        | 20   |      | ms   |    |
| I <sub>SLEEP</sub>               | Sleep current (total device leakage including MOSFET channels)  | V <sub>BB</sub> ≤ 18V, V <sub>ENx</sub> = V <sub>DIAG_EN</sub> = 0V, V <sub>OUT</sub> = 0V                               |  | T <sub>A</sub> = 25°C  |      | 0.5  | μA   |    |
|                                  |   |  |  | T <sub>A</sub> = 125°C |      | 2    | μA   |    |
| I <sub>OUT(sleep)</sub>          | Output leakage current per channel                              | V <sub>BB</sub> ≤ 18V, V <sub>ENx</sub> = V <sub>DIAG_EN</sub> = 0V, V <sub>OUT</sub> = 0V                               |  | T <sub>A</sub> = 25°C  |      | 0.01 | 0.2  | μA |
|                                  |   |  |  | T <sub>A</sub> = 125°C |      |      | 0.5  | μA |
| I <sub>L,NOM</sub>               | Continuous load current, per channel                            | All channels enabled   |  | T <sub>A</sub> = 85°C  |      | 2    | A    |    |
|                                  |   | One channel enabled  |  |                        |      | 3    | A    |    |
| <b>RON CHARACTERISTICS</b>       |   |  |  |                        |      |      |      |    |

## 6.5 Electrical Characteristics (continued)

$V_{BB} = 6V$  to  $18V$ ,  $T_A = -40^\circ C$  to  $125^\circ C$  (unless otherwise noted); Typical application is  $13.5V$ ,  $1A$ ,  $RILIM = Open$  (unless otherwise specified). Digital input pins are EN1, EN2, EN3, EN4, SEL0, SEL1, DIAG\_EN.

| PARAMETER                            |   | TEST CONDITIONS                              |  | MIN  | TYP  | MAX | UNIT      |
|--------------------------------------|---|--|--|------|------|-----|-----------|
| $R_{ON}$                             | On-resistance   | $5V < V_{BB} \leq 28V$ , $I_{OUT} = 1A$      | $T_J = 25^\circ C$                         |      | 120  |     | $m\Omega$ |
|                                      |   |  | $T_J = 150^\circ C$                        |      |      | 250 | $m\Omega$ |
|                                      |   | $3V \leq V_{BB} \leq 5V$ , $I_{OUT} = 1A$    | $T_J = 25^\circ C$                         |      |      | 175 | $m\Omega$ |
|                                      |   |  | $T_J = 150^\circ C$                        |      |      | 280 | $m\Omega$ |
| $\Delta R_{ON}$                      | Percentage difference in $R_{ON}$ between channels                      | $5V < V_{BB} \leq 28V$ , $I_{OUT} = 1A$      | $T_J = -40^\circ C$ to $150^\circ C$       |      | 5    |     | %         |
| $R_{ON(REV)}$                        | On-resistance during reverse polarity                                   | $-18V \leq V_{BB} \leq -6V$                  | $T_J = 25^\circ C$                         |      | 120  |     | $m\Omega$ |
|                                      |   |  | $T_J = 150^\circ C$                        |      |      | 250 | $m\Omega$ |
| $V_F$                                | Body diode forward conduction voltage                                   | $V_{EN} = 0V$ , $I_{OUT} = -0.1A$            |  |      | 0.8  | 1   | V         |
| <b>CURRENT SENSE CHARACTERISTICS</b> |   |  |  |      |      |     |           |
| $K_{SNS}$                            | Current sense ratio $I_{OUT} / I_{SNS}$                                 | $I_{OUT} = 1A$                               |  |      | 1040 |     |           |
| $I_{SNS}$                            | Current sense current and accuracy                                      | $V_{EN} = V_{DIAG\_EN} = 5V$                 | $I_{OUT} = 2A$                             |      | 1.9  |     | $mA$      |
|                                      |   |  |  |      | -4   | 3   | %         |
|                                      |   |  | $I_{OUT} = 1.5A$                           |      | 1.43 |     | $mA$      |
|                                      |   |  |  |      | -4   | 3   | %         |
|                                      |   |  | $I_{OUT} = 750mA$                          |      | 0.72 |     | $mA$      |
|                                      |   |  |  |      | -4   | 4   | %         |
|                                      |   |  | $I_{OUT} = 300mA$                          |      | 0.29 |     | $mA$      |
|                                      |   |  |  |      | -5   | 5   | %         |
|                                      |   |  | $I_{OUT} = 100mA$                          |      | 0.1  |     | $mA$      |
|                                      |   |  |  |      | -12  | 12  | %         |
| $I_{OUT} = 75mA$                     |   | 0.072  |  | $mA$ |      |     |           |
|                                      |   | -16  | 16   | %    |      |     |           |
| $I_{OUT} = 30mA$                     |   | 0.03   |  | $mA$ |      |     |           |
|                                      |   | -35  | 35   | %    |      |     |           |
| $I_{OUT} = 15mA$                     |   | 0.014  |  | $mA$ |      |     |           |
|                                      |   | -75  | 75   | %    |      |     |           |
| <b>SNS CHARACTERISTICS</b>           |   |  |  |      |      |     |           |
| $V_{SNSFH}$                          | $V_{SNS}$ fault high-level  | $V_{DIAG\_EN} = 5V$ , $R_{SNS} = 1k\Omega$   |  | 4.5  | 5    | 5.2 | V         |
|                                      |   | $V_{DIAG\_EN} = 3.3V$ , $R_{SNS} = 1k\Omega$ |  | 3.2  | 3.6  | 3.9 | V         |
|                                      |   | $V_{DIAG\_EN} = 1.8V$ , $R_{SNS} = 1k\Omega$ |  | 3.2  | 3.6  | 3.9 | V         |
| $I_{SNSFH}$                          | $I_{SNS}$ fault high-level  | $V_{DIAG\_EN} > V_{IH,DIAG\_EN}$             |  | 4.5  |      | 6.5 | $mA$      |
| $V_{BB\_ISNS}$                       | $V_{BB}$ headroom needed for full current sense and fault functionality | $V_{DIAG\_EN} = 3.3V$                        | Measured with respect to GND pin of device | 5    |      |     | V         |
|                                      |   | $V_{DIAG\_EN} = 5V$                          |  | 6.5  |      |     | V         |
| <b>CURRENT LIMIT CHARACTERISTICS</b> |   |  |  |      |      |     |           |

## 6.5 Electrical Characteristics (continued)

$V_{BB} = 6V$  to  $18V$ ,  $T_A = -40^\circ C$  to  $125^\circ C$  (unless otherwise noted); Typical application is  $13.5V$ ,  $1A$ ,  $R_{ILIM} = \text{Open}$  (unless otherwise specified). Digital input pins are EN1, EN2, EN3, EN4, SEL0, SEL1, DIAG\_EN.

| PARAMETER                    |  | TEST CONDITIONS   |                              | MIN  | TYP  | MAX                  | UNIT       |
|------------------------------|--|---|------------------------------|------|------|----------------------|------------|
| $I_{CL}$                     | $I_{CL}$ current limit setting                               | $R_{ILIM} > 60k\Omega$ (ILIM = OPEN)  |                              | 3.8  | 4.8  | 5.6                  | A          |
|                              |  | $R_{ILIM} < 1.1k\Omega$ (ILIM = GND)  |                              | 1.9  | 2.2  | 2.4                  | A          |
|                              |  | $R_{ILIM} = 2.49k\Omega$  |                              |      | 1.9  |                      | A          |
|                              |  | $R_{ILIM} = 4.87k\Omega$  |                              |      | 1.7  |                      | A          |
|                              |  | $R_{ILIM} = 9.76k\Omega$  |                              |      | 1.5  |                      | A          |
|                              |  | $R_{ILIM} = 16.5k\Omega$  |                              | 1.1  | 1.25 | 1.4                  | A          |
|                              |  | $R_{ILIM} = 23.2k\Omega$  |                              |      | 1    |                      | A          |
|                              |  | $R_{ILIM} = 31.6k\Omega$  |                              |      | 0.75 |                      | A          |
|                              |  | $R_{ILIM} = 43.2k\Omega^{(1)}$  |                              |      | 0.5  |                      | A          |
|                              |  | $R_{ILIM} = 57.6k\Omega^{(1)}$  |                              | 0.19 | 0.25 | 0.32                 | A          |
| $I_{CL\_LINPK}$              | Linear Mode peak   | $T_J = -40^\circ C$ to $150^\circ C$ ,<br>$dI/dt < 0.01$ A/ms   | $I_{LIM} = 0.25A$ to $2.2A$  |      |      | $1.6 \times I_{CL}$  | A          |
| $I_{CL\_ENPS}$               | Peak current enabling into permanent short                   | $T_J = -40^\circ C$ to $150^\circ C$  | Load = $5\mu H + 100m\Omega$ |      |      | $2.25 \times I_{CL}$ | A          |
| $I_{OVCR}$                   | OVCR Peak current when short is applied while switch enabled | $T_J = -40^\circ C$ to $150^\circ C$  | Load = $5\mu H + 100m\Omega$ |      |      | 12                   | A          |
| <b>FAULT CHARACTERISTICS</b> |  |   |                              |      |      |                      |            |
| $R_{OL}$                     | Open-load (OL) detection internal resistor                   | $V_{EN} = 0V$ , $V_{DIAG\_EN} = 5V$   |                              | 100  | 150  | 175                  | $k\Omega$  |
| $t_{OL}$                     | Open-load (OL) detection deglitch time                       | $V_{EN} = 0V$ , $V_{DIAG\_EN} = 5V$ , When $V_{BB} - V_{OUT} < V_{OL}$ , duration longer than $t_{OL}$ . Openload detected. |                              |      | 300  | 500                  | $\mu s$    |
| $V_{OL}$                     | Open-load (OL) detection voltage                             | $V_{EN} = 0V$ , $V_{DIAG\_EN} = 5V$   |                              |      |      | 1.5                  | V          |
| $t_{OL1}$                    | OL and STB indication-time from EN falling                   | $V_{EN} = 5V$ to $0V$ , $V_{DIAG\_EN} = 5V$<br>$I_{OUT} = 0mA$ , $V_{OUT} = V_{BB} - V_{OL}$                                |                              |      |      | 500                  | $\mu s$    |
| $t_{OL2}$                    | OL and STB indication-time from DIA_EN rising                | $V_{EN} = 0V$ , $V_{DIAG\_EN} = 0V$ to $5V$<br>$I_{OUT} = 0mA$ , $V_{OUT} = V_{BB} - V_{OL}$                                |                              |      |      | 600                  | $\mu s$    |
| $T_{ABS}$                    | CHx Thermal shutdown threshold                               |   |                              | 162  |      |                      | $^\circ C$ |
| $T_{HYS}$                    | CHx Thermal shutdown hysteresis                              |   |                              |      |      | 30                   | $^\circ C$ |
| $T_{REL}$                    | CHx Relative thermal shutdown                                |   |                              |      | 80   |                      | $^\circ C$ |
| $t_{FAULT\_FLT}$             | Fault indication-time  | $V_{DIAG\_EN} = 5V$<br>Time between fault and $\overline{FLT}$ asserting  |                              |      |      | 60                   | $\mu s$    |
| $t_{FAULT\_SNS}$             | Fault indication-time  | $V_{DIAG\_EN} = 5V$<br>Time between fault and $I_{SNS}$ settling at $V_{SNSFH}$   |                              |      |      | 60                   | $\mu s$    |
| $t_{RETRY}$                  | Retry time   | Time from fault shutdown until switch re-enable (thermal shutdown).   |                              | 1    | 2    | 3                    | ms         |
| <b>LOW POWER MODE</b>        |  |   |                              |      |      |                      |            |
| $I_{LPM,enter}$              | Load current level for entry to LPM                          | $t > t_{STBY}$  |                              | 83   | 110  | 137                  | mA         |
| $I_{LPM,exit}$               | Load current level for exit of LPM                           |   |                              | 130  | 165  | 200                  | mA         |
| $R_{DSON,LPM}$               | $R_{DSON}$ in Low Power Mode                                 | $50mA$ $I_{LOAD}$   |                              |      | 130  |                      | $m\Omega$  |



## 6.5 Electrical Characteristics (continued)

$V_{BB} = 6V$  to  $18V$ ,  $T_A = -40^\circ C$  to  $125^\circ C$  (unless otherwise noted); Typical application is  $13.5V$ ,  $1A$ ,  $R_{LIM} = \text{Open}$  (unless otherwise specified). Digital input pins are EN1, EN2, EN3, EN4, SEL0, SEL1, DIAG\_EN.

| PARAMETER                                 |  | TEST CONDITIONS  |                                | MIN | TYP                  | MAX | UNIT      |
|---|--|--|--------------------------------|-----|----------------------|-----|-----------|
| $I_{Q,LPM}$                               | Quiescent current per channel in LPM with all channels enabled | $0mA I_{LOAD}$   | $-40^\circ C$ to $125^\circ C$ |     |                      | 20  | $\mu A$   |
| $t_{LPM}$                                 | LPM Transition indication-time                                 | Device in LPM transition out time between current increase and $\overline{LPM}$ asserting    |                                |     |                      | 50  | $\mu s$   |
| $t_{WAKE}$                                | Recovery/Exit time from LPM                                    | Device in LPM transition out time between wake interrupt (EN, DIAG_EN pin) and LPM asserting |                                |     |                      | 50  | $\mu s$   |
| $I_{PKLPM,exit}$                          | Current peak coming out of LPM. Current setting $\leq 2.25A$   | Peak current for immediate shutoff in LPM  | $-40^\circ C$ to $125^\circ C$ |     | $1.6 \times I_{LIM}$ |     |           |
| <b>DIGITAL INPUT PIN CHARACTERISTICS</b>  |  |  |                                |     |                      |     |           |
| $V_{IL,DIN}$                              | Input voltage low-level  | No GND Network   |                                |     |                      | 0.8 | V         |
| $V_{IH,DIN}$                              | Input voltage high-level                                       | No GND Network   |                                | 1.5 |                      |     | V         |
| $V_{IHYS,DIN}$                            | Input voltage hysteresis                                       |  |                                | 100 |                      |     | mV        |
| $R_{PD,DIN}$                              | Internal pulldown resistor for ENx, DIAG_EN                    |  |                                | 0.7 | 1                    | 1.3 | $M\Omega$ |
|   | Internal pulldown resistor for SEL0, SEL1                      |  |                                | 0.7 | 1                    | 1.3 | $M\Omega$ |
| $I_{IH,DIN}$                              | Input current high-level for SEL0, SEL1                        | $V_{DINx} = 5.5V$  |                                |     |                      | 10  | $\mu A$   |
|   | Input current high-level for DIAG_EN                           | $V_{DIAG\_EN} = 5.5V$  |                                |     |                      | 30  | $\mu A$   |
| $I_{IH,DIN}$                              | Input current high-level for ENx                               | $V_{ENx} = 5.5V$   |                                |     |                      | 30  | $\mu A$   |
| <b>DIGITAL OUTPUT PIN CHARACTERISTICS</b> |  |  |                                |     |                      |     |           |
| $V_{LPM}$                                 | LPM low output voltage   | $I_{LPM} = 2mA$  |                                |     |                      | 0.4 | V         |
| $V_{FLT}$                                 | $\overline{FLT}$ low output voltage                            | $I_{FLT} = 2mA$  |                                |     |                      | 0.4 | V         |

(1) If using GND network, accuracy for this current limit setting will be shifted from the table value

## 6.6 SNS Timing Characteristics

$V_{BB} = 6V$  to  $18V$ ,  $T_A = -40^\circ C$  to  $125^\circ C$  (unless otherwise noted)

| PARAMETER                         |  | TEST CONDITIONS   |  | MIN | TYP | MAX | UNIT    |
|-----------------------------------|--|---|--|-----|-----|-----|---------|
| <b>SNS TIMING - CURRENT SENSE</b> |  |   |  |     |     |     |         |
| $t_{SNSION1}$                     | Settling time from rising edge of DIAG_EN<br>50% of $V_{DIAG\_EN}$ to 90% of settled ISNS                      | $V_{EN} = 5V$ , $V_{DIAG\_EN} = 0V$ to $5V$<br>$R_{SNS} = 1k\Omega$ , $I_L = 30mA$                            |  |     |     | 60  | $\mu s$ |
|                                   |  | $V_{ENx} = 5V$ , $V_{DIAG\_EN} = 0V$ to $5V$<br>$R_{SNS} = 1k\Omega$ , $I_L = 1A$                             |  |     |     | 30  | $\mu s$ |
| $t_{SNSION2}$                     | Settling time from rising edge of EN and DIAG_EN<br>50% of $V_{DIAG\_EN}$ $V_{EN}$ to 90% of settled ISNS      | $V_{EN} = V_{DIAG\_EN} = 0V$ to $5V$<br>$V_{BB} = 13.5V$ $R_{SNS} = 1k\Omega$ , $R_{LOAD} = 20\Omega$         |  |     |     | 150 | $\mu s$ |
| $t_{SNSION3}$                     | Settling time from rising edge of EN with DIAG_EN HI;<br>50% of $V_{DIAG\_EN}$ $V_{EN}$ to 90% of settled ISNS | $V_{EN} = 0V$ to $5V$ , $V_{DIAG\_EN} = 5V$ , $V_{BB} = 13.5V$ , $R_{SNS} = 1k\Omega$ , $R_{LOAD} = 20\Omega$ |  |     |     | 150 | $\mu s$ |
| $t_{SNSIOFF}$                     | Settling time from falling edge of DIAG_EN   | $V_{EN} = 5V$ , $V_{DIAG\_EN} = 5V$ to $0V$ $V_{BB} = 13.5V$<br>$R_{SNS} = 1k\Omega$ , $R_L = 20\Omega$       |  |     |     | 20  | $\mu s$ |

## 6.6 SNS Timing Characteristics (continued)

$V_{BB} = 6V$  to  $18V$ ,  $T_A = -40^\circ C$  to  $125^\circ C$  (unless otherwise noted)

| PARAMETER     |  | TEST CONDITIONS  | MIN | TYP | MAX | UNIT    |
|---------------|--|--|-----|-----|-----|---------|
| $t_{SETTLEH}$ | Settling time from rising edge of load step          | $V_{EN} = 5V$ , $V_{DIAG\_EN} = 5V$<br>$R_{SNS} = 1k\Omega$ , $I_{OUT} = 10mA$ to $1A$             |     |     | 20  | $\mu s$ |
| $t_{SETTLEL}$ | Settling time from falling edge of load step         | $V_{EN} = 5V$ , $V_{DIAG\_EN} = 5V$<br>$R_{SNS} = 1k\Omega$ , $I_{OUT} = 1A$ to $10mA$             |     |     | 20  | $\mu s$ |
| $t_{SELx}$    | Multi-sense transition delay from channel to channel | $V_{EN} = 5V$ , $V_{DIAG\_EN} = 5V$<br>$R_{SNS} = 1k\Omega$ , $I_{OUT1} = 1A$ to $I_{OUT2} = 0.5A$ |     |     | 50  | $\mu s$ |

## 6.7 Switching Characteristics

$V_{BB} = 13.5V$ ,  $T_A = -40^\circ C$  to  $125^\circ C$  (unless otherwise noted)

| PARAMETER          |   | TEST CONDITIONS   | MIN | TYP | MAX  | UNIT       |
|--------------------|---|---|-----|-----|------|------------|
| $t_{DR}$           | Channel Turn-on delay time (from Active)        | $V_{BB} = 13.5V$ , $R_L = 1k\Omega$ 50% of EN to 10% of VOUT                |     | 30  | 55   | $\mu s$    |
|                    | Channel Turn-on delay time (from Sleep or LPM)  |   |     | 40  | 60   | $\mu s$    |
| $t_{DF}$           | Channel Turn-off delay time (from Active)       | $V_{BB} = 13.5V$ , $R_L = 10\Omega$ 50% of EN to 90% of VOUT                |     | 30  | 55   | $\mu s$    |
|                    | Channel Turn-off delay time (from LPM)          |   |     | 30  | 85   | $\mu s$    |
| $SR_R$             | VOUT rising slew rate                           | $V_{BB} = 13.5V$ , 20% to 80% of VOUT, $R_L = 10\Omega$                     | 0.1 | 0.3 | 0.55 | V/ $\mu s$ |
| $SR_F$             | VOUT falling slew rate                          | $V_{BB} = 13.5V$ , 80% to 20% of VOUT, $R_L = 10\Omega$                     | 0.1 | 0.3 | 0.5  | V/ $\mu s$ |
| $t_{ON}$           | Channel Turn-on time (Standby delay to Active)  | $V_{BB} = 13.5V$ , $R_L = 10\Omega$ 50% of EN to 80% of VOUT                | 30  | 50  | 100  | $\mu s$    |
| $t_{OFF}$          | Channel Turn-off time (Active to Standby delay) | $V_{BB} = 13.5V$ , $R_L = 10\Omega$ 50% of EN to 20% of VOUT                | 30  | 70  | 145  | $\mu s$    |
| $t_{ON} - t_{OFF}$ | Turn-on and off matching                        | 1ms enable pulse $V_{BB} = 13.5V$ , $R_L = 10\Omega$                        | -40 |     | 40   | $\mu s$    |
|                    |   | 200- $\mu s$ enable pulse, $V_{BB} = 13.5V$ , $R_L = 10\Omega$ ,            | -40 |     | 40   | $\mu s$    |
| $\Delta_{PWM}$     | PWM accuracy - average load current             | 200- $\mu s$ enable pulse (1ms period), $V_{BB} = 13.5V$ , $R_L = 10\Omega$ | -25 |     | 25   | %          |
|                    |   | $\leq 500Hz$ , 50% Duty cycle $V_{BB} = 13.5V$ , $R_L = 10\Omega$           | -12 |     | 12   | %          |
| $E_{ON}$           | Switching energy losses during turn-on          | $V_{BB} = 13.5V$ , $R_L = 10\Omega$   |     | 0.5 |      | mJ         |
| $E_{OFF}$          | Switching energy losses during turn-off         | $V_{BB} = 13.5V$ , $R_L = 10\Omega$   |     | 0.5 |      | mJ         |

## 6.8 Typical Characteristics

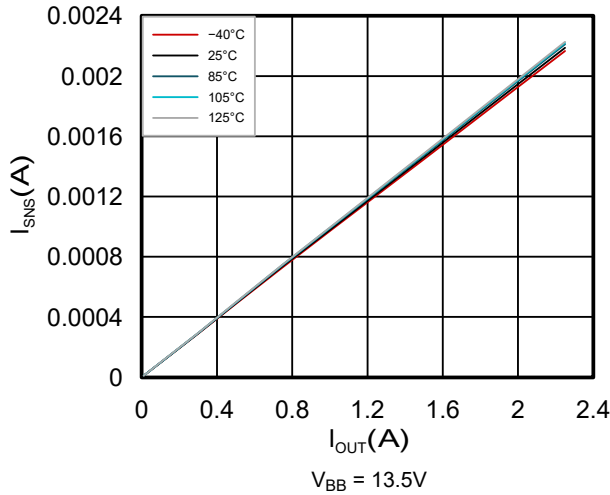

Figure 6-1.  $I_{SNS}$  vs  $I_{OUT}$  Over Temperature

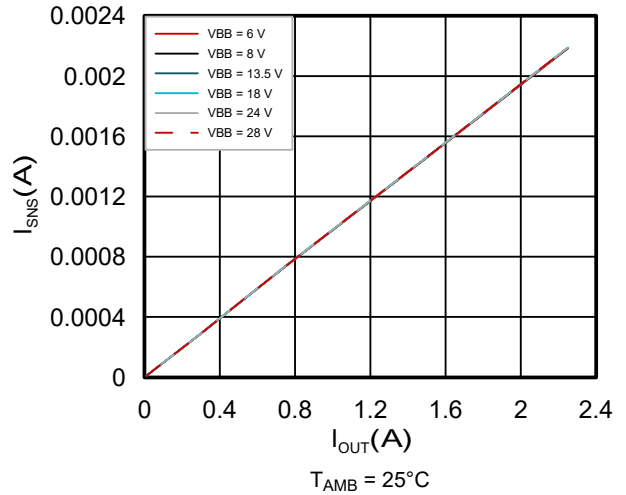

Figure 6-2.  $I_{SNS}$  vs  $I_{OUT}$  Over  $V_{BB}$  Voltage

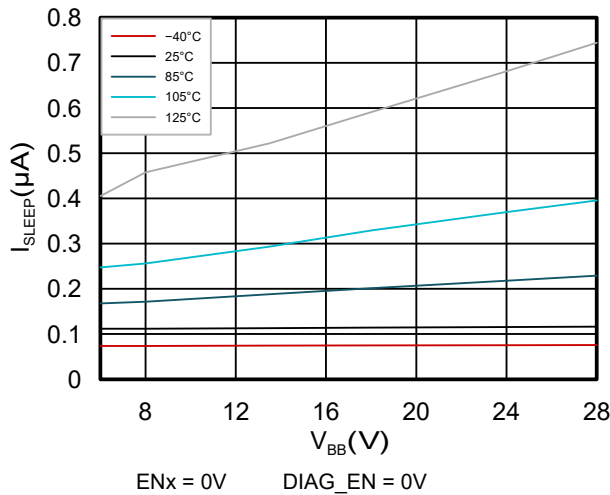

Figure 6-3.  $I_{SLEEP}$  vs  $V_{BB}$  Over Temperature

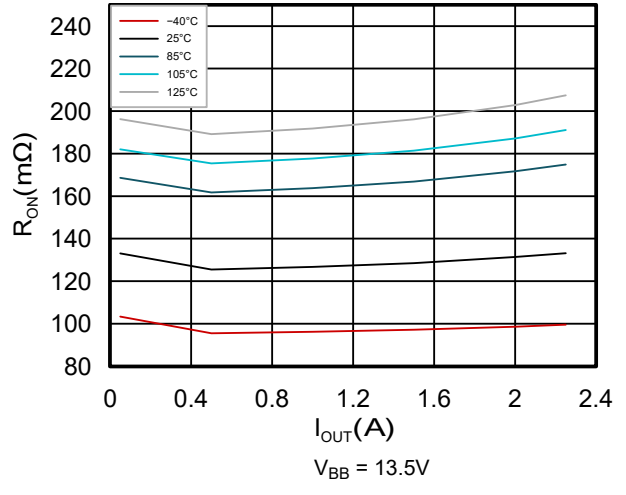

Figure 6-4.  $R_{ON}$  vs  $I_{OUT}$  Over Temperature

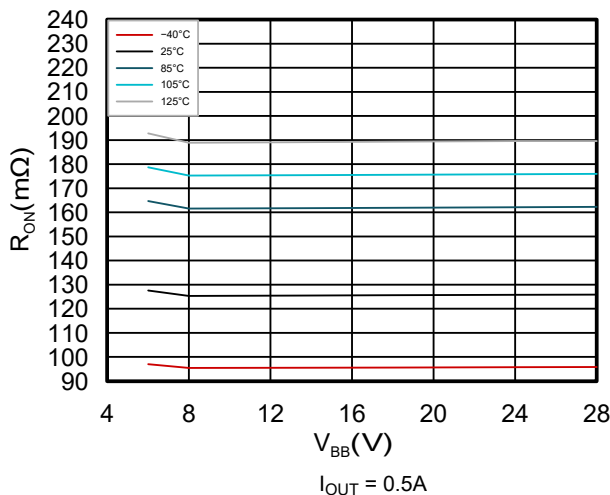

Figure 6-5.  $R_{ON}$  vs  $V_{BB}$  Over Temperature

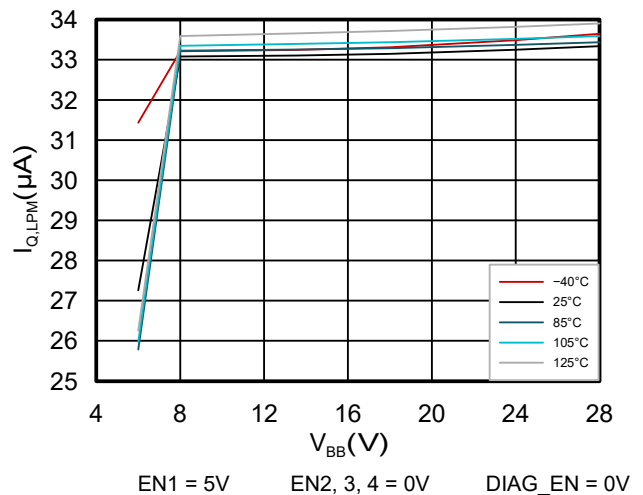

Figure 6-6.  $I_{Q,LPM}$  vs  $V_{BB}$  Over Temperature When 1 Channel is Enabled

### 6.8 Typical Characteristics (continued)

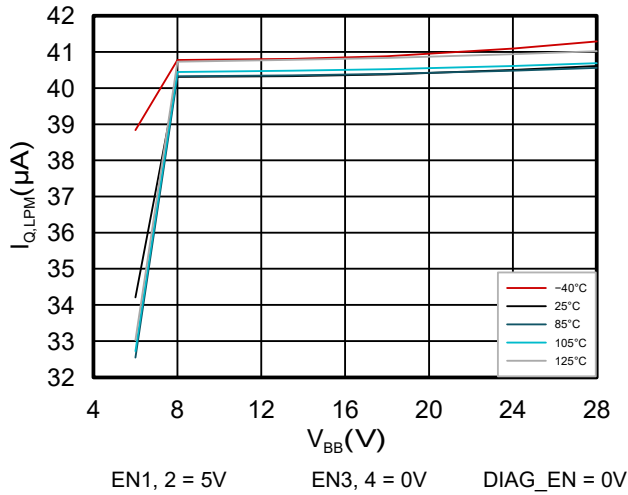

Figure 6-7.  $I_{Q,LPM}$  vs  $V_{BB}$  Over Temperature When 2 Channels are Enabled

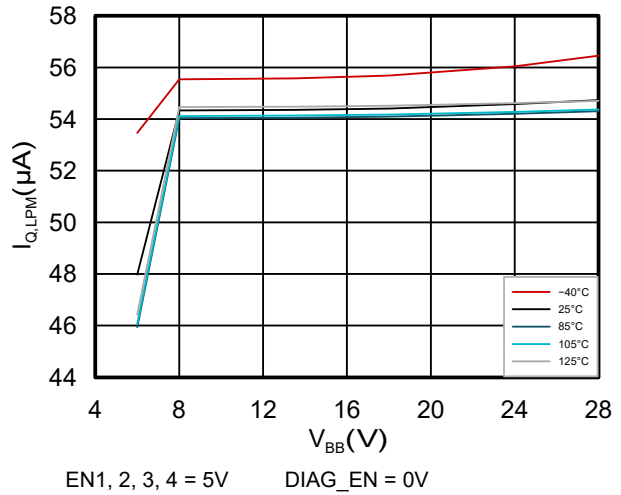

Figure 6-8.  $I_{Q,LPM}$  vs  $V_{BB}$  Over Temperature When 4 Channels are Enabled

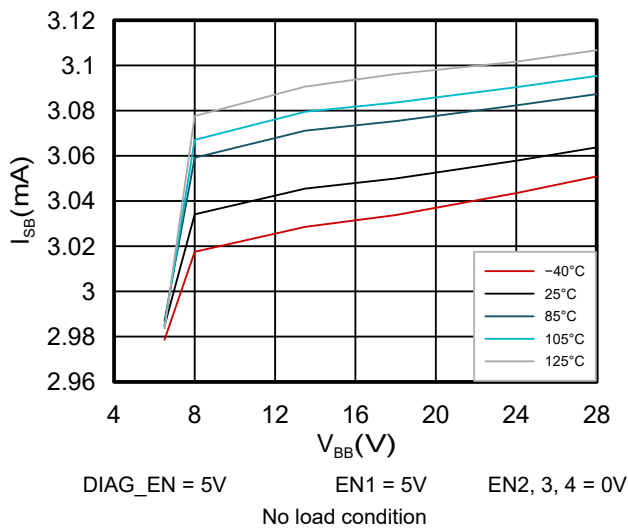

Figure 6-9.  $I_{SB}$  vs  $V_{BB}$  Over Temperature

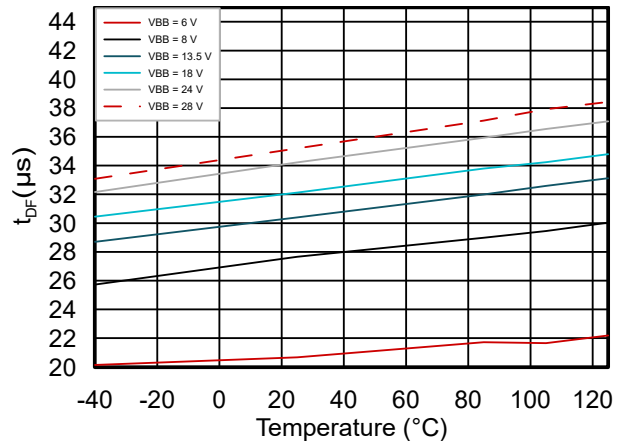

Figure 6-10.  $t_{DF}$  vs Temperature Over  $V_{BB}$  Voltage

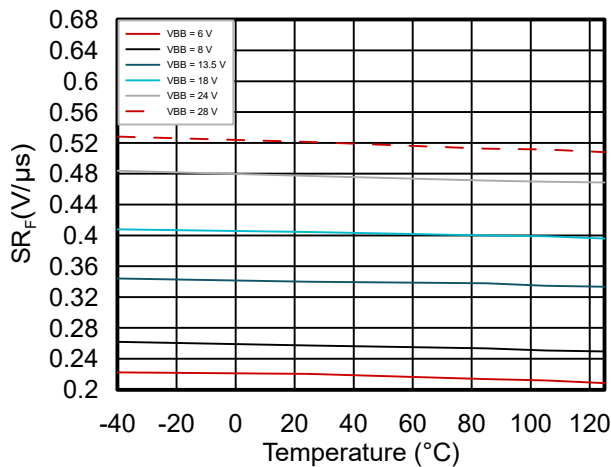

Figure 6-11.  $S_{RF}$  vs Temperature Over  $V_{BB}$  Voltage

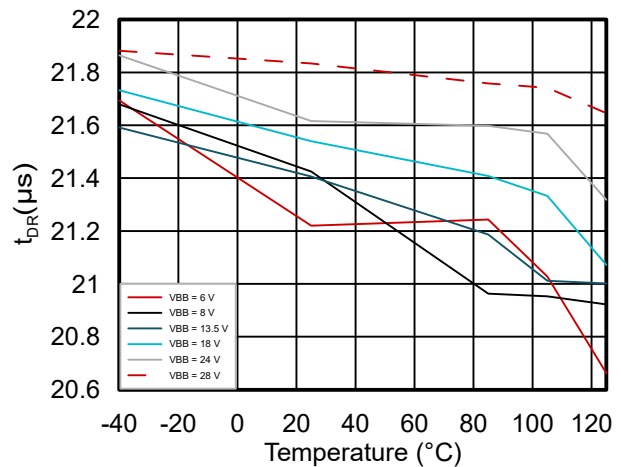

Figure 6-12.  $t_{DR}$  vs Temperature Over  $V_{BB}$  Voltage

### 6.8 Typical Characteristics (continued)

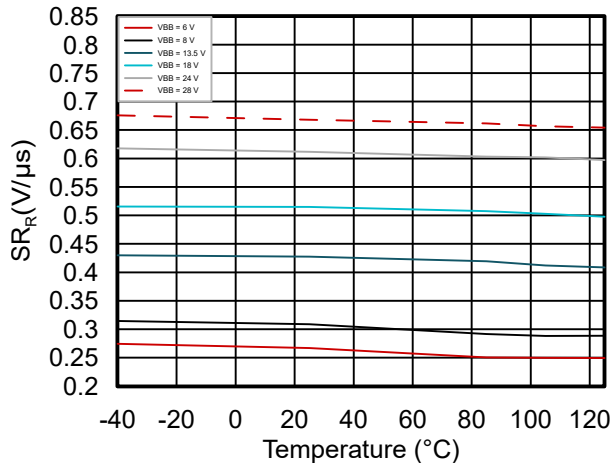

Figure 6-13. SR<sub>R</sub> vs Temperature Over V<sub>BB</sub> Voltage

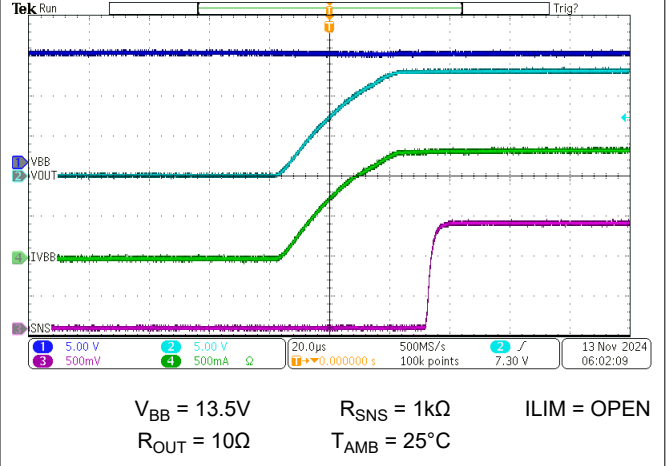

Figure 6-14. Switch Turn-On

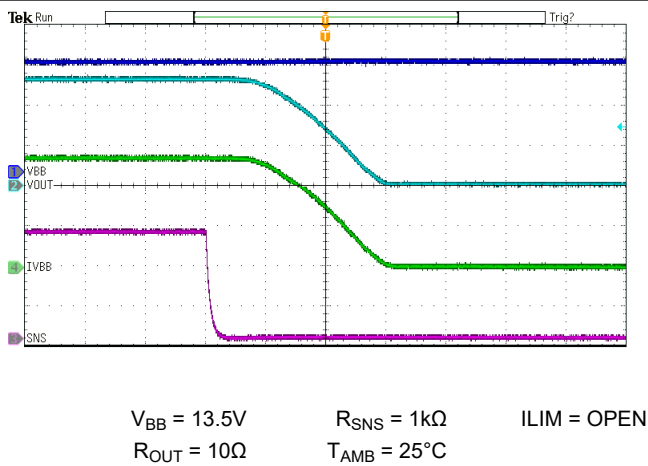

Figure 6-15. Switch Turn-Off

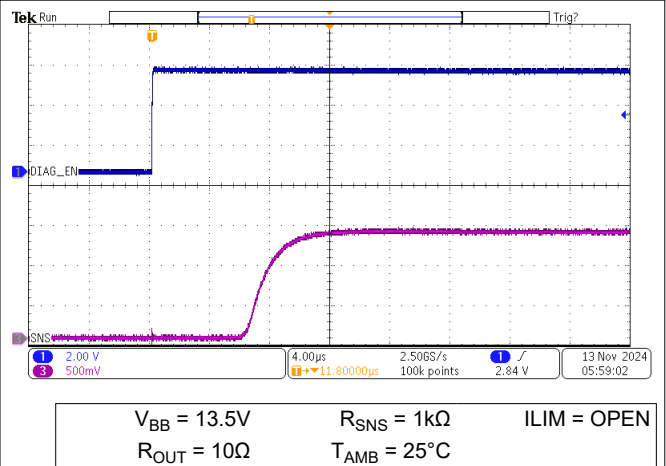

Figure 6-16. SNS Pin Voltage With DIAG\_EN Turning On

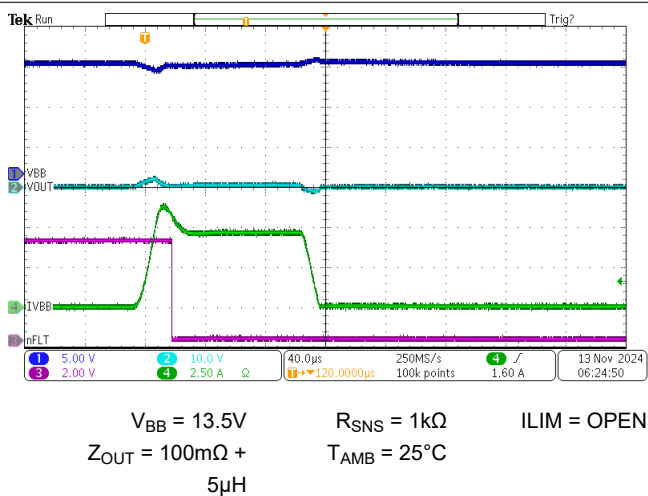

Figure 6-17. Permanent Short Behavior With ILIM Open

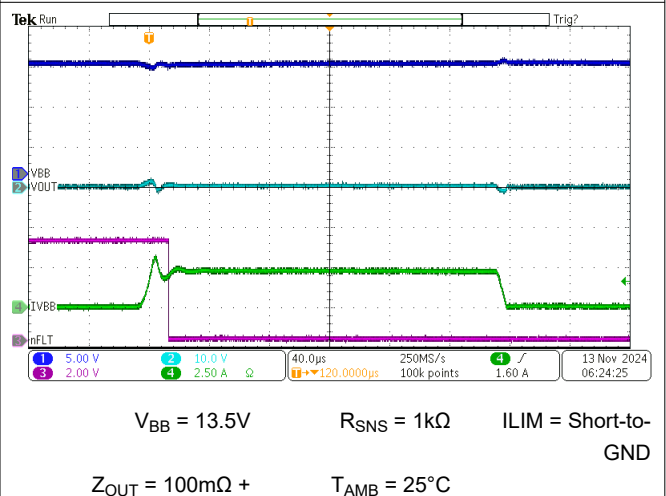

Figure 6-18. Permanent Short Behavior With ILIM Short-to-GND

## 7 Detailed Description

### 7.1 Overview

The TPS4HC120-Q1 device is a smart high-side switch, with internal charge pump and quad-channel integrated NMOS power FETs. Full diagnostics and high-accuracy current-sense features enable intelligent control of the load. The adjustable current-limit function greatly improves the reliability of the whole system.

The device has logic pins to enable each of the four channels and a separate pin to enable the diagnostic output with two pins to select the channel to be output on the analog current SNS pin. It also implements a global FLT pin to be used as an interrupt to the MCU.

The external high-accuracy current limit allows setting the current-limit value by applications. When overcurrent occurs, the device improves system reliability by clamping the inrush current effectively. The device can also save system cost by reducing the size of PCB traces and connectors, and the capacity of the preceding power stage.

For inductive loads (relays, solenoids, valves), the device implements an active clamp between drain and source to protect itself. During the inductive switching-off cycle, both the energy of the power supply and the load are dissipated on the high-side switch. The device also optimizes the switching-off slew rate when the clamp is active, which helps the system design by keeping the effects of transient power and EMI to a minimum.

When the current consumptions on all channels are small, along with other requirements described in [Entry into LPM](#), the device automatically enters the Low Power Mode. This state has ultra-low quiescent current consumption, and is suitable for the loads that are active when the vehicle is OFF to preserve the battery. There is a dedicated LPM pin that indicates the mode of the device, and can be used as an interrupt signal to wake up the MCU.

The TPS4HC120-Q1 device is able to drive a wide variety of resistive, inductive, and capacitive loads, including low-wattage bulbs, LEDs, relays, solenoids, heaters, and sub-modules.

### 7.2 Functional Block Diagram

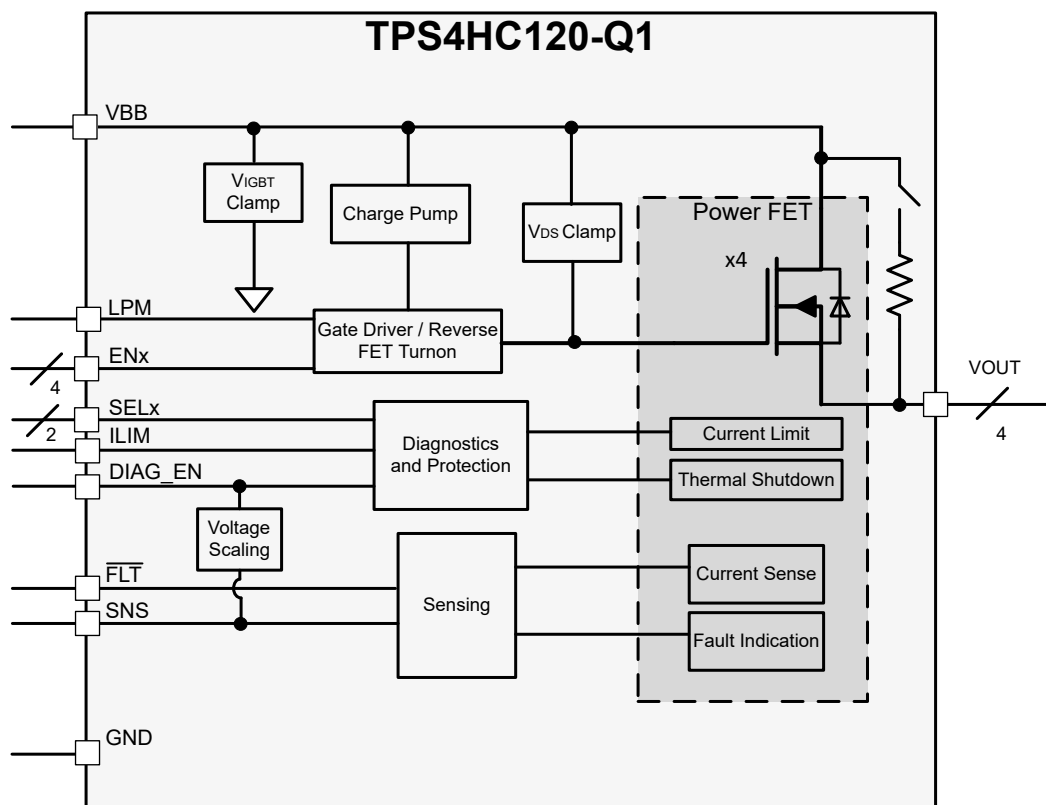

## 7.3 Feature Description

### 7.3.1 Pin Current and Voltage Conventions

For reference purposes throughout the data sheet, current directions on their respective pins are as shown by the arrows in [Figure 7-1](#). All voltages are measured relative to the ground plane.

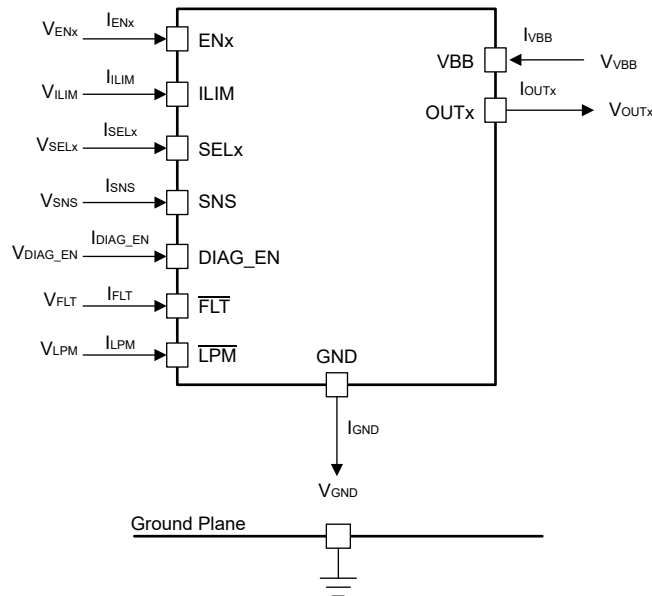

**Figure 7-1. Voltage and Current Conventions**

### 7.3.2 Low Power Mode

Low power mode (LPM) is designed to be able to still provide small amounts of current to loads without consuming much quiescent current. This type of feature is useful in power-at-all-time loads or to just generally reduce the amount of power dissipation from the supply. The quiescent current draw during this mode is defined in [Section 6.5](#) under  $I_{Q,LPM}$ . The TPS4HC120-Q1 can automatically enter and exit this mode by detecting that the load current is below  $I_{LPM,enter}$  on all active channels, and then exits this mode when load current increases above  $I_{LPM,exit}$ . This section describes the entry, exit and protections mechanisms in this mode.

#### Entry into LPM

When the load current going through the channel is below the  $I_{LPM,enter}$  threshold on all active channels and diagnostics are turned off (DIAG\_EN is low) for longer than  $t_{STBY}$ , the device automatically enters into LPM. This means that the digital core is turned off and the charge pump strength is reduced to reduce the quiescent current to  $I_{Q,LPM}$ .

All the requirements below need to be met for the device to enter the LPM automatically:

- $T_J < 125^\circ\text{C}$
- $V_{BB} \geq 6\text{V}$
- DIAG\_EN is LOW
- At least one channel is ON
- All the ON channels have load currents  $< I_{LPM,enter}$  per channel
- No EN pin toggling
- All the above conditions are true for time longer than  $t_{STBY}$

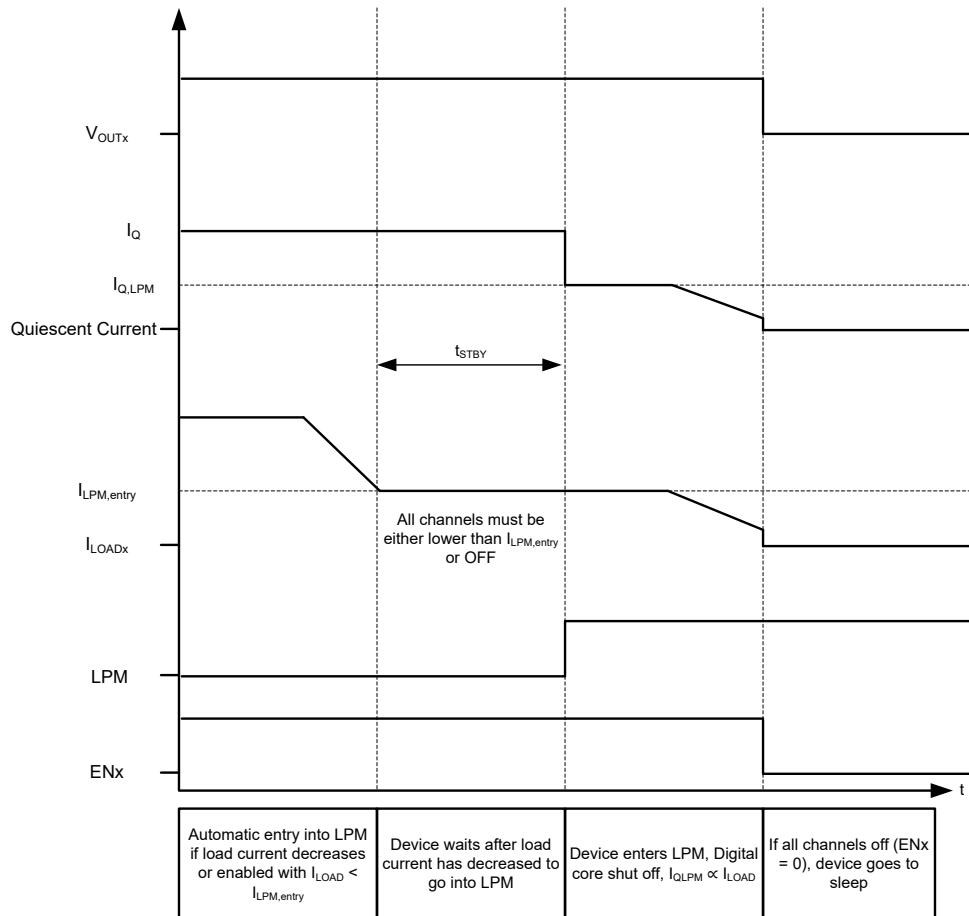

**Figure 7-2. Entering LPM**

### During LPM

The quiescent current of the device during LPM,  $I_{Q,LPM}$ , is a function of how many channels are active and is proportional to the load current meaning that the lower the load current during this time, the lower the quiescent current is. Additionally, since the digital core is disabled, the diagnostics like current sensing or open load detection are not available during this mode. If diagnostics are desired, the DIAG\_EN pin can be enabled to exit LPM and return the part back to normal operation. Once DIAG\_EN is disabled the device goes back into LPM after  $t_{STBY}$ . Similarly, the current limit mechanism is not active in the same manner as by definition the minimum current limit is higher than the entry point of LPM. However, the short-circuit protection will still be in place to protect the device.

Below is the summary of the behavior of the device during LPM:

- $I_q$  reduces to  $I_{Q,LPM}$  per channel
- $R_{DS,ON}$  per channel increases to  $R_{DS,ON,LPM}$
- No clamped current limit for overload conditions as the device will exit the LPM first
- Short-circuit protection is in place to shut off the device if load current increases to  $I_{PKLPM,exit}$  during LPM
- No thermal shutdown protection

### Exiting LPM

The device exits LPM if any of four conditions is met:



- Load current increases slowly: If the load current increases beyond  $I_{LPM,exit}$  slowly, the device wakes up and pulls the LPM pin low to signal the device is no longer in low power mode. The output voltage droop is minimal.

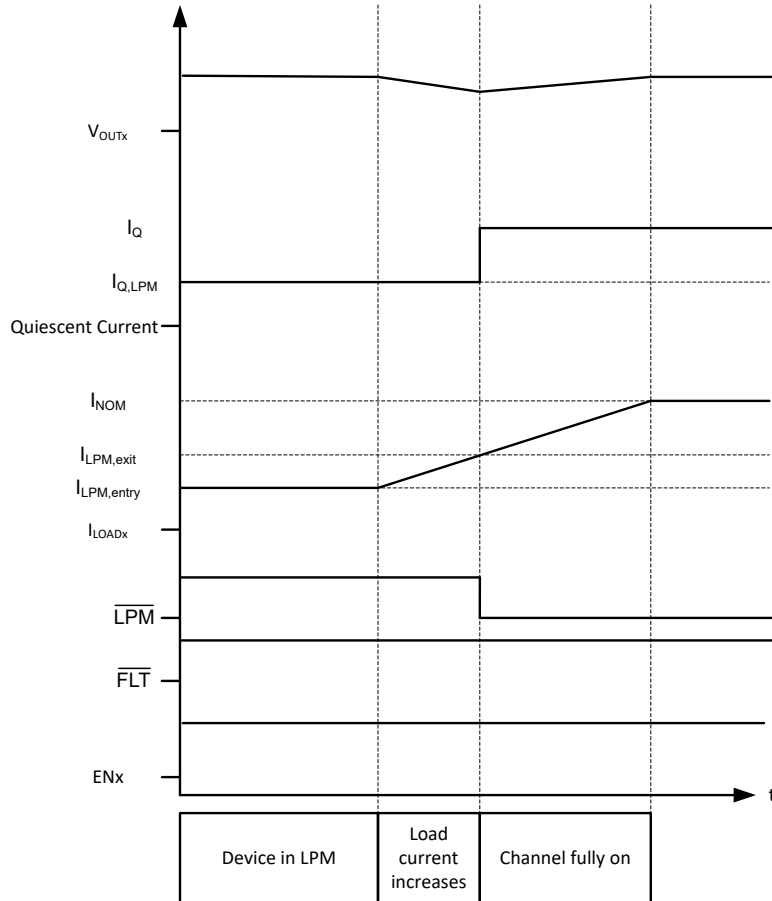

**Figure 7-3. Exiting LPM With Load Current Slow Increase**

- Load current increases rapidly (short-circuit): If the load current increases rapidly beyond  $I_{LPM,exit}$ , the device shuts down to protect itself and come back on within the  $t_{WAKE}$  time in normal operation with full functionality. As the part comes back on, LPM pin is pulled LOW to represent that the part has come out of LPM. The  $\overline{FLT}$  pin will also be pulled low is the fault is still present.

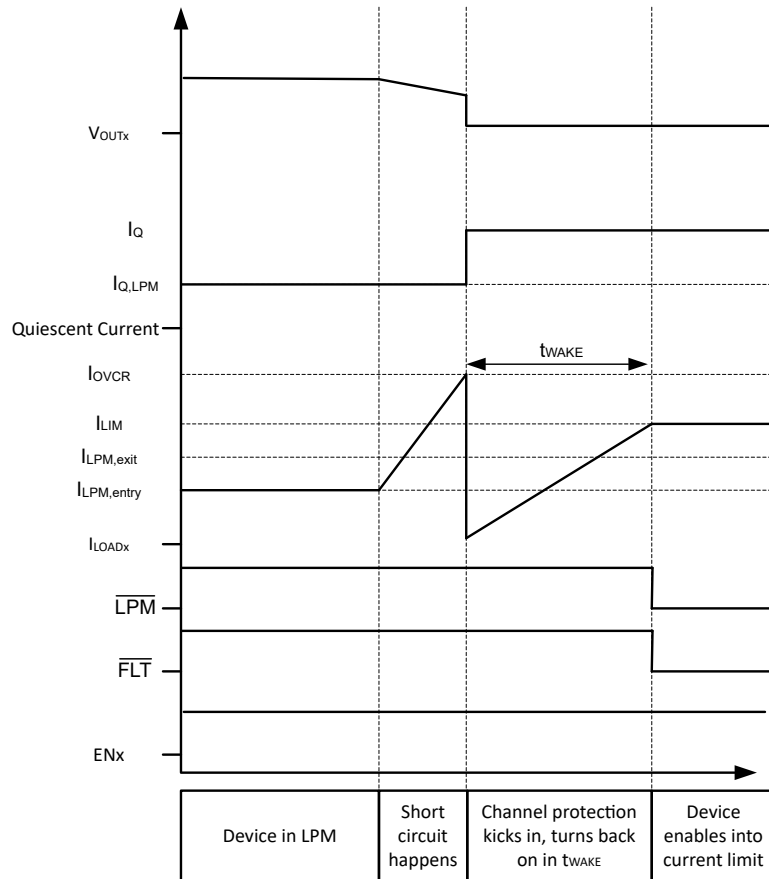

**Figure 7-4. Exiting LPM With Rapid Load Current Increase (Short-Circuit)**

- Any EN<sub>x</sub> is toggled (from ON to OFF or OFF to ON): If any channel is turned ON or turned OFF during LPM, the device wakes up and perform the desired action. After the device wakes up, if the LPM entry conditions are still met, the part enters LPM again after t<sub>STBY</sub>.
- DIAG\_EN is turned ON: if DIAG\_EN goes high, the device goes into the DIAGNOSTIC mode which fully turns on the part so that all of the functionality works as intended in the DIAGNOSTIC state. If DIAG\_EN goes back low, with all LPM entry conditions are met, the part goes back into LPM after t<sub>STBY</sub>.

Any time the device comes out of LPM to ACTIVE state, the LPM pin is pulled LOW. If the system needs to wake up when the device comes out of LPM, the LPM pin can be used to send a wake up signal to the MCU. Otherwise the LPM pin can be ignored.

### 7.3.3 Accurate Current Sense

The high-accuracy current-sense function is internally implemented, which allows a better real-time monitoring effect and more-accurate diagnostics without further calibration. A current mirror is used to source  $1 / K_{SNS}$  of the load current, flowing out to the external resistor between the SNS pin and GND, and reflected as voltage on the SNS pin.

$K_{SNS}$  is the ratio of the output current and the sense current. The accuracy values of  $K_{SNS}$  quoted in the electrical characteristics do take into consideration temperature and supply voltage. Each device was internally calibrated while in production, so post-calibration by users is not required in most cases.

The maximum voltage out on the SNS pin is clamped to V<sub>SNSFH</sub>, which is the fault voltage level. To make sure that this voltage is not higher than the system can tolerate, the max voltage at the DIAG\_EN pin has been limited to the voltage at the SNS pin. If DIAG\_EN is between V<sub>IH</sub> and 3.3V, the maximum output on the SNS pin is approximately 3.3V. However, if the voltage at DIAG\_EN is above 3.3V, then the fault SNS voltage, V<sub>SNSFH</sub>, tracks that voltage up to 5V. Tracking is done because the GPIO voltage output that is powering the

diagnostics through DIAG\_EN is close to the maximum acceptable ADC voltage within the same microcontroller. Therefore, the sense resistor value,  $R_{SNS}$ , can be chosen to maximize the range of currents needed to be measured by the system. The  $R_{SNS}$  value must be chosen based on application need. The maximum usable  $R_{SNS}$  value is bounded by the ADC minimum acceptable voltage,  $V_{ADC,min}$ , for the smallest load current needed to be measured by the system,  $I_{LOAD,min}$ . The minimum acceptable  $R_{SNS}$  value has to ensure the  $V_{SNS}$  voltage is below the  $V_{SNSFH}$  value so that the system can correctly determine faults. This difference between the maximum readable current through the SNS pin,  $I_{LOAD,max} \times R_{SNS}$ , and the  $V_{SNSFH}$  is called the headroom voltage,  $V_{HR}$ . The headroom voltage is determined by the system but is important so that there is a difference between the maximum readable current and a fault condition. Therefore, the minimum  $R_{SNS}$  value has to be the  $V_{SNSFH}$  minus the  $V_{HR}$  times the sense current ratio,  $K_{SNS}$  divided by the maximum load current the system must measure,  $I_{LOAD,max}$ . Use the following equation to set the boundary equation.

$$V_{ADC,min} \times K_{SNS} / I_{LOAD,min} \leq R_{SNS} \leq (V_{SNSFH} - V_{HR}) \times K_{SNS} / I_{LOAD,max} \quad (1)$$

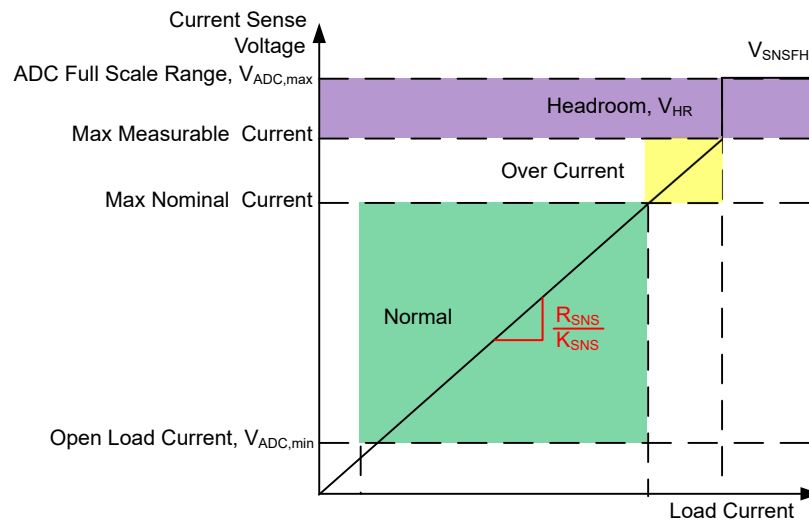

Figure 7-5. Voltage Indication on the Current-Sense Pin

The maximum current the system wants to read,  $I_{LOAD,max}$ , must be below the current-limit threshold because after the current-limit threshold is tripped the  $V_{SNS}$  value goes to  $V_{SNSFH}$ .

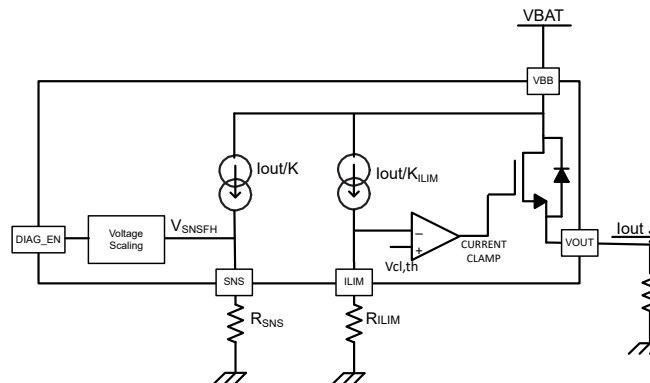

Figure 7-6. Current-Sense and Current-Limit Block Diagram

Because this scheme adapts based on the voltage coming in from the MCU, there is no need to have a Zener diode on the SNS pin to protect from high voltages.

### 7.3.4 Adjustable Current Limit

A high-accuracy adjustable current limit allows higher reliability, which protects the power supply and wires during short circuit or power up by being programmed to an acceptable level. Also, current limiting can save system costs by reducing PCB traces, connector size, capacity of the preceding power stage and possibly reducing wire gauge.

Current limit offers protection from over-stressing to the load and integrated power FET. The current limit regulates the output current to the set value, asserts the  $\overline{\text{FLT}}$  pin, and pulls up the SNS pin to  $V_{\text{SNSFH}}$  if the device is set up to output that channel on the SNS pin.

- The device can be programmed to different current limit values through an external resistor on the ILIM pin. There are 10 current limit settings which can be set based on resistor values in [Table 7-1](#).  $\leq 1\%$  tolerance resistors should be used for  $R_{\text{ILIM}}$  resistor.

**Table 7-1. Current Limit Setting Through External Resistor**

| ALLOWED RESISTOR VALUE(1)      | ILIM THRESHOLD |
|--------------------------------|----------------|
| 57.6k $\Omega$                 | 250mA          |
| 43.2k $\Omega$                 | 500mA          |
| 31.6k $\Omega$                 | 750mA          |
| 23.2k $\Omega$                 | 1A             |
| 16.5k $\Omega$                 | 1.25A          |
| 9.76k $\Omega$                 | 1.5A           |
| 4.87k $\Omega$                 | 1.75A          |
| 2.49k $\Omega$                 | 2A             |
| Short to GND (<1.1k $\Omega$ ) | 2.25A          |
| Open (>60 k $\Omega$ )         | 5A             |

#### Note

Any resistor settings that are not listed in this table can be interpreted as one of the adjacent levels, which is not a recommended configuration.

To set a different inrush current limit and steady state current limit, the current limit resistor can be changed dynamically when the device is ON. MOSFET based control scheme can be adopted for changing the current limit on the fly. However, the components and the layout at ILIM pin need to be considered carefully to minimize the capacitance at the pin. Any capacitance  $\geq 100\text{pF}$  at ILIM pin might affect the current limit functionality. MOSFET with low input capacitance needs to be selected for dynamic current limit.

A current limit event occurs when  $I_{\text{OUTX}}$  reaches the regulation threshold level,  $I_{\text{CL}}$ . When  $I_{\text{OUT}}$  reaches the current limit threshold,  $I_{\text{CL}}$ , the device can remain enabled and limit  $I_{\text{OUTX}}$  to  $I_{\text{CL}}$ . When the device remains enabled (and limits  $I_{\text{OUT}}$ ), thermal shutdown may be triggered due to the high amount of power dissipation in the FET. The regulation loop response when the device is enabled into a short circuit is shown in [Figure 7-7](#). The figure is showing the scenario with the auto-retry version listed in [Section 4](#). The LATCH version will latch off after the first thermal shutdown. Please note that the current may peak at a higher value ( $I_{\text{CL\_ENPS}}$ ) than the regulation threshold ( $I_{\text{CL}}$ ).

When an over-current event occurs, the current limit must respond quickly in order to limit the peak current seen on short circuits (both hot and enabling into a short). The peak has to be limited to ensure that the supply does not droop for a given amount of supply capacitance. This is especially important in applications where the device is powered from a DC/DC instead of car battery.

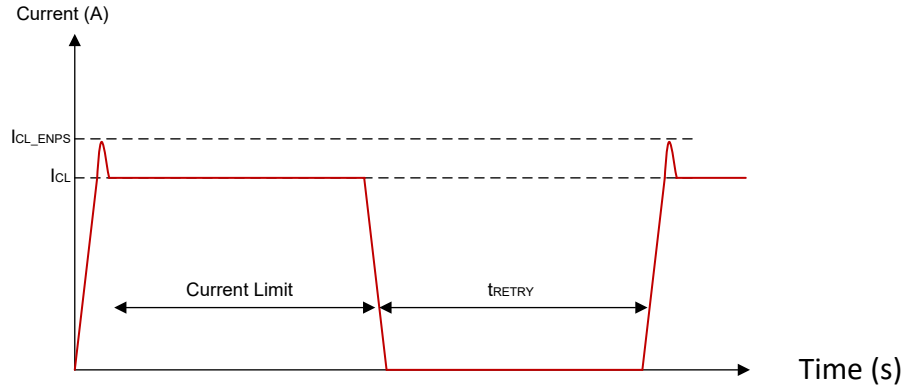

**Figure 7-7. Enable Into Short Current Limit (auto-retry version)**

However, a higher ( $I_{CL\_LINPK}$ ) output current than the current limit regulation loop threshold ( $I_{CL}$ ) may be available from the switch during an overload condition before the current limitation is applied.

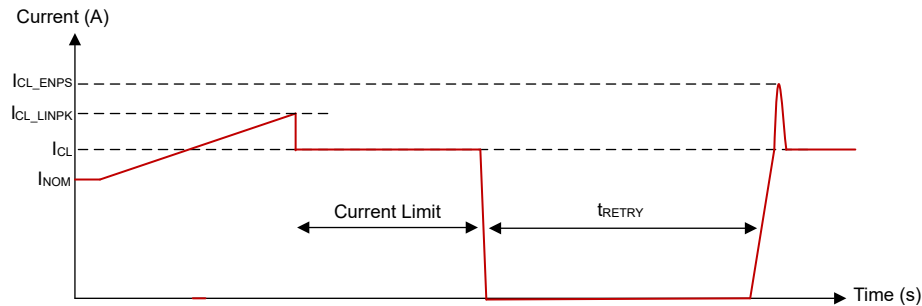

**Figure 7-8. Linear Peak From Soft Short (auto-retry version)**

The device applies a strong pulldown to limit the current during the short circuit event while the switch is enabled. The current will then drop down to zero before the current limit regulation loop engages and the switch turn-on and the behavior will be similar to the enable into a short circuit case.

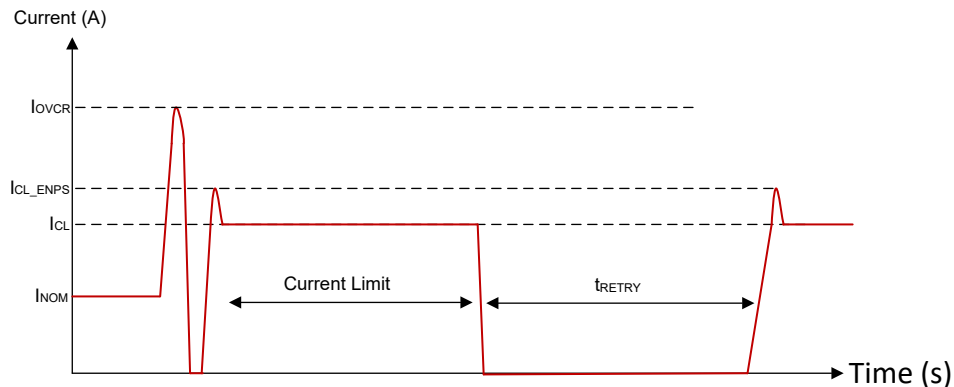

**Figure 7-9. Hot Short Event (auto-retry version)**

### 7.3.5 Inductive-Load Switching-Off Clamp

When switching an inductive load off, the inductive reactance tends to pull the output voltage negative. Excessive negative voltage could cause the power FET to break down. To protect the power FET, an internal clamp between drain and source is implemented, namely  $V_{DS(clamp)}$ .

$$V_{DS(clamp)} = V_{VS} - V_{OUT} \tag{2}$$

During the period of demagnetization ( $t_{decay}$ ), the power FET is turned on for inductance-energy dissipation. The total energy is dissipated in the high-side switch. Total energy includes the energy of the power supply ( $E_{(VS)}$ ) and the energy of the load ( $E_{(load)}$ ). If resistance is in series with inductance, some of the load energy is dissipated on the resistance.

$$E_{(HSS)} = E_{(VS)} + E_{(load)} = E_{(VS)} + E_{(L)} - E_{(R)} \tag{3}$$

When an inductive load switches off,  $E_{(HSS)}$  causes high thermal stressing on the device. The upper limit of the power dissipation depends on the device intrinsic capacity, ambient temperature, and board dissipation condition.

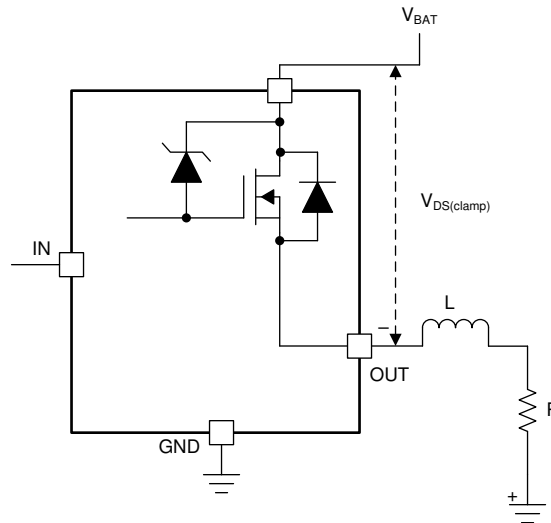

**Figure 7-10. Drain-to-Source Clamping Structure**

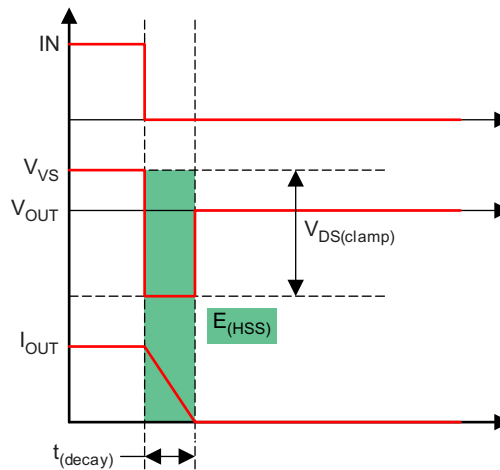

**Figure 7-11. Inductive Load Switching-Off Diagram**

From the perspective of the high-side switch,  $E_{(HSS)}$  equals the integration value during the demagnetization period.

$$E_{(HSS)} = \int_0^{t_{(decay)}} V_{DS(clamp)} \times I_{OUT}(t) dt$$

$$t_{(decay)} = \frac{L}{R} \times \ln \left( \frac{R \times I_{OUT(max)} + |V_{OUT}|}{|V_{OUT}|} \right)$$

$$E_{(HSS)} = L \times \frac{V_{VS} + |V_{OUT}|}{R^2} \times \left[ R \times I_{OUT(max)} - |V_{OUT}| \ln \left( \frac{R \times I_{OUT(max)} + |V_{OUT}|}{|V_{OUT}|} \right) \right] \quad (4)$$

When R approximately equals 0,  $E_{(HSD)}$  can be given simply as:

$$E_{(HSS)} = \frac{1}{2} \times L \times I_{OUT(max)}^2 \frac{V_{VS} + |V_{OUT}|}{|V_{OUT}|} \quad (5)$$

Note that for PWM-controlled inductive loads, it is recommended to add the external freewheeling circuitry shown in [Figure 7-12](#) to protect the device from repetitive power stressing. TVS is used to achieve the fast decay. See [Figure 7-12](#) for more details.

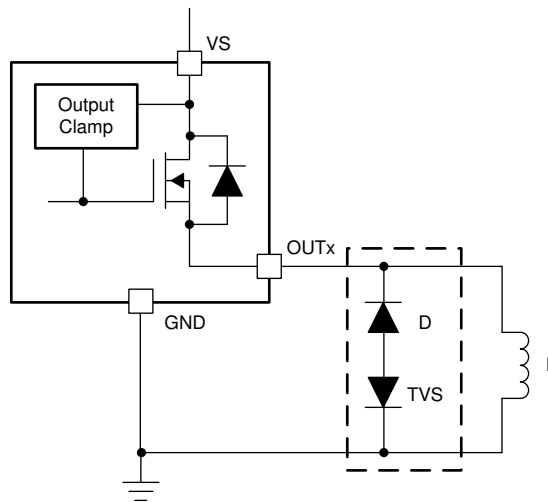

**Figure 7-12. Protection With External Circuitry**

### 7.3.6 Fault Detection and Reporting

#### 7.3.6.1 Diagnostic Enable Function

The DIAG\_EN pin enables or disables the diagnostic functions. If multiple devices are used, but the ADC resource is limited in the microcontroller, the MCU can use GPIOs to set DIAG\_EN high to enable the diagnostics of one device while disabling the diagnostics of the other devices by setting DIAG\_EN low. In addition, the device can keep the power consumption to a minimum by setting DIAG\_EN and ENx low.

#### 7.3.6.2 Multiplexing of Current Sense

SELx pins are used to multiplex the shared current-sense function among the four channels within the same device. Pulling each pin high or low sets the corresponding channel to be output on the SNS pin if DIAG\_EN is high.  $\overline{FLT}$  still represents a global interrupt that goes low if a fault occurs on any channel.

If current sense information needs to be multiplexed across different devices, then it is not recommended to directly tie the SNS pins together across multiple devices. When the DIAG\_EN is LOW, there is an internal clamp at SNS pin that clamps the voltage to approximately 2V. One device SNS pin might affect the other devices SNS readback if tied directly.

To use SNS pin across multiple devices, it is recommended to connect individual SNS pin to different analog input pins of MCU, as illustrated in Figure 7-13. Alternatively, an external analog MUX can be used to connect to a single MCU pin, as illustrated in Figure 7-14.

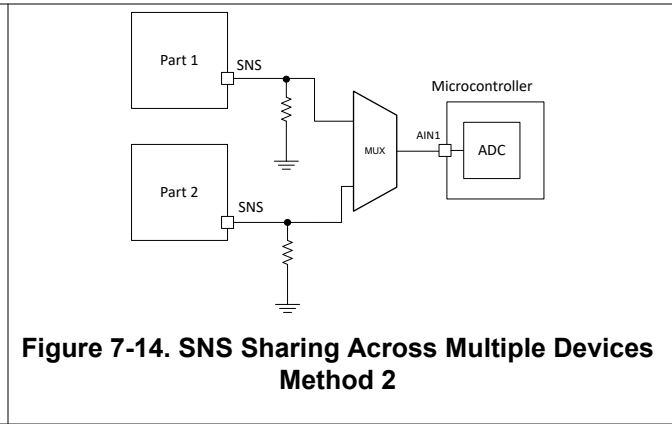
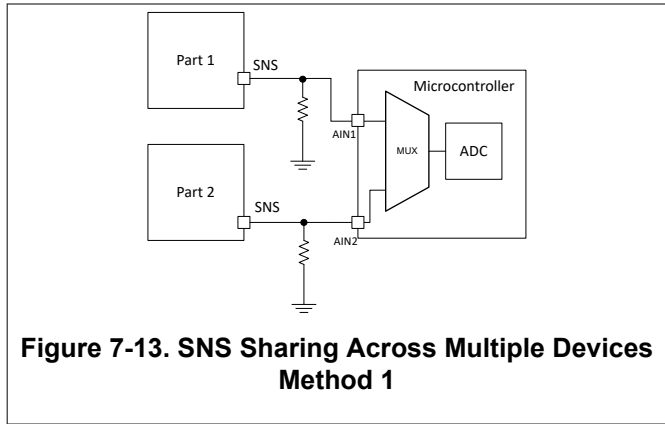

**Table 7-2. Diagnosis Configuration Table**

| DIAG_EN | ENx | SEL0 | SEL1 | SNS ACTIVATED CHANNEL | SNS   | FLT           | PROTECTIONS AND DIAGNOSTICS                  |
|---------|-----|------|------|-----------------------|---|---------------|--|
| L       | H   | —    | —    | —                     | 0V. Clamp to 2V internally if external voltage is applied to the pin. | See Table 7-3 | SNS disabled, FLT reporting, full protection |
|         | L   |      |      |                       |   | High-Z        | Diagnostics disabled, no protection          |
| H       | —   | 0    | 0    | Channel 1             | See Table 7-3   | See Table 7-3 | See Table 7-3                                |
|         |     | 0    | 1    | Channel 2             |   |               |  |
|         |     | 1    | 0    | Channel 3             |   |               |  |
|         |     | 1    | 1    | Channel 4             |   |               |  |

### 7.3.6.3 FAULT Reporting

The global  $\overline{\text{FLT}}$  pin is used to monitor the global fault condition among all the channels. When a fault condition occurs on any channel, the  $\overline{\text{FLT}}$  pin is pulled down to GND. A 3.3-V or 5-V external pullup is required to match the supply level of the microcontroller. The  $\overline{\text{FLT}}$  pin reports faults on any channel as long as the device is not in the SLEEP or LOW POWER MODE.

After the  $\overline{\text{FAULT}}$  report, the microcontroller can check and identify the channel in fault status by multiplexed current sensing. The SNS pin also works as a fault report with an internal pullup voltage,  $V_{\text{SNSFH}}$  if DIAG\_EN is high.

### 7.3.6.4 Fault Table

**Table 7-3. Fault Table**

| CONDITIONS  | ENx | OUTx   | SNS (if DIAG_EN is high)           | $\overline{\text{FLT}}$ (with external pull-up) | BEHAVIOR  | FAULT RECOVERY |
|-------------|-----|--|------------------------------------|---|---|----------------|
| Normal      | L   | L  | 0                                  | H   | Normal  | —              |
|             | H   | $V_{\text{BB}} - I_{\text{LOAD}} \times R_{\text{ON}}$ | $I_{\text{LOAD}} / K_{\text{SNS}}$ | H   | Normal  | —              |
| Overcurrent | H   | $V_{\text{BB}} - I_{\text{LIM}} \times R_{\text{ON}}$  | $V_{\text{SNSFH}}$                 | L   | Holds the current at the current limit until thermal shutdown or when the overcurrent event is removed. | Auto           |



**Table 7-3. Fault Table (continued)**

| CONDITIONS   | ENx   | OUTx | SNS (if DIAG_EN is high)       | FLT (with external pull-up) | BEHAVIOR   | FAULT RECOVERY  |
|--|-------|------|--------------------------------|-----------------------------|--|---|
| Open load, short to battery, reverse polarity        | L     | H    | $V_{SNSFH}$                    | L                           | Internal pull-up resistor is active. Fault is asserted when $V_{VS} - V_{OUTx} < V_{(ol,off)}$ | Auto  |
|  | H     | H    | $I_{LOAD} / K_{SNS} \approx 0$ | H                           | Normal behavior. User can make judgement based on SNS pin output.                              | —   |
| Hot short  | H     | L    | $V_{SNSFH}$                    | L                           | Device will immediately shutdown, and re-enable into current limit.                            | Auto-retry into current limit until thermal shutdown. Auto-retry version will repeat until the fault goes away. Latch version will need toggle EN after first thermal shutdown. |
| Enable into permanent short                          | L → H | L    | $V_{SNSFH}$                    | L                           | Device will enable into current limit until thermal shutdown.                                  | Enable into current limit until thermal shutdown. Auto-retry version will repeat until the fault goes away. Latch version will need toggle EN after first thermal shutdown.     |
| Absolute thermal shutdown, Relative thermal shutdown | H     | L    | $V_{SNSFH}$                    | L                           | Shuts down when devices hits relative or absolute thermal shutdown.                            | For auto-retry version, output auto-retry after $t_{RETRY}$ . Fault recovers when $T_J < T_{HYS}$ or when ENx toggles. Latch version can recover only when EN toggles.          |
| Reverse polarity                                     | X     | X    | X                              |                             | X  | Channel turns on to lower power dissipation. Current into ground pin needs to be limited by external ground network.  |

### 7.3.7 Full Diagnostics

#### 7.3.7.1 Short-to-GND and Overload Detection

When a channel is on, a short to GND or overload condition causes overcurrent. If the overcurrent triggers either the internal or external current-limit threshold, the fault condition is reported out. The microcontroller can handle the overcurrent by turning off the switch. The device will clamp the current to  $I_{CL}$  until thermal shutdown. TPS4HC120A automatically recovers when the fault condition is removed.

In a hot short condition, when the short-circuit is applied when the EN is HIGH, the device will shutdown immediately and auto-retry the same as enable into permanent short condition, as shown in [Figure 7-9](#).

#### 7.3.7.2 Open-Load Detection

##### 7.3.7.2.1 Channel On

When a channel is ON, benefiting from the high-accuracy current sense in the small current range, if an open-load event occurs, it can be detected as an ultra low  $V_{SNS}$  and handled by the microcontroller. Note that the detection is not reported on the  $\overline{FAULT}$  pin or the fault registers. The microcontroller must multiplex the SEL and SEH pins to output the correct channel out on the SNS pin.

##### 7.3.7.2.2 Channel Off

In the OFF state, when DIAG\_EN is high, there is an internal pull-up resistor  $R_{OL}$  that pulls up a channel to  $V_{BB}$ . The specific channel that gets pulled up is based on the selection of SEL0 and SEL1, and the other channels do not have the pull-up resistor engaged.

If there is load present at the selected channel, then the output voltage is pulled to around 0V, as the load is much stronger than the  $R_{OL}$ . In the case of an open load, the output voltage will be pulled close to the supply

voltage by the  $R_{OL}$ . If  $V_{BB} - V_{OUT} < V_{OL,off}$  for the selected channel, the  $\overline{FLT}$  pin goes low to indicate the fault to the MCU, and the SNS pin is pulled up to  $I_{SNSFH}$ .

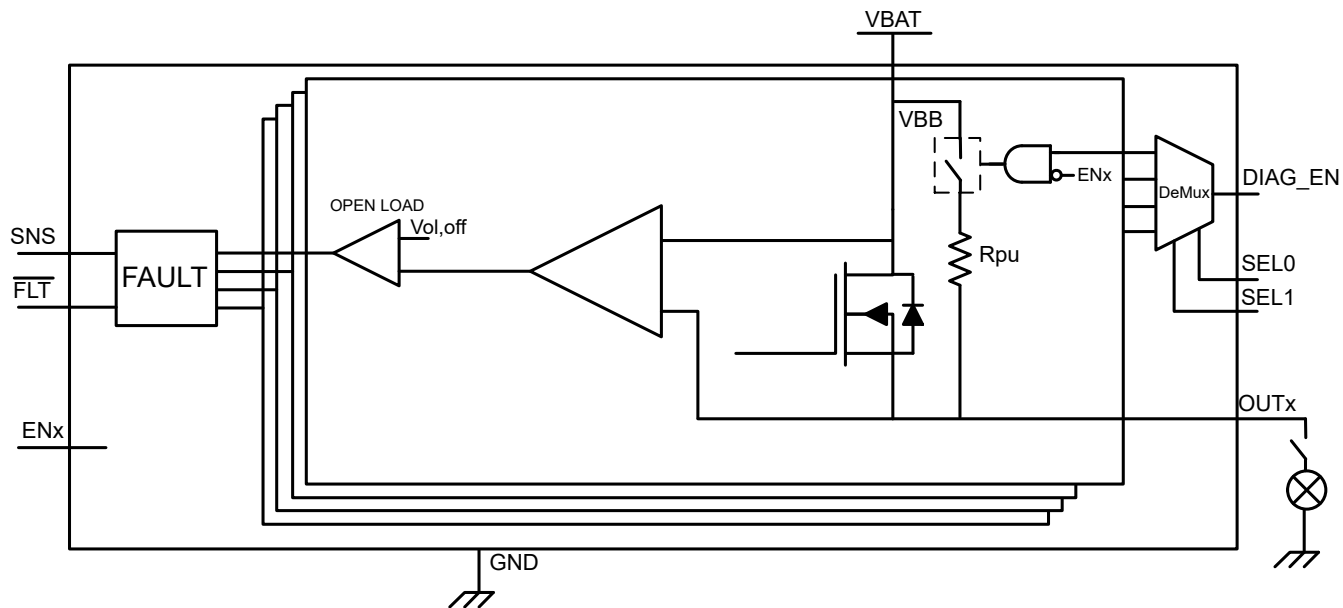

Figure 7-15. Open-Load Detection in Off-State

### 7.3.7.3 Short-to-Battery Detection

Short-to-battery has the same detection mechanism and behavior as open-load detection, in both the on-state and off-state. See [Table 7-3](#) for more details.

### 7.3.7.4 Reverse-Polarity and Battery Protection

Reverse-polarity, commonly referred to as reverse battery, occurs when the ground of the device goes to the battery potential,  $V_{GND} = V_{BAT}$ , and the supply pin goes to ground,  $V_{BB} = 0V$ . In this case, if the EN2 pin has a path to the *ground* plane, then the FET turns on to lower the power dissipation through the main channel and prevent current flow through the body diode. Note that the resistor/diode ground network (if there is not a central blocking diode on the supply) must be present for the device to protect itself during a reverse battery event.

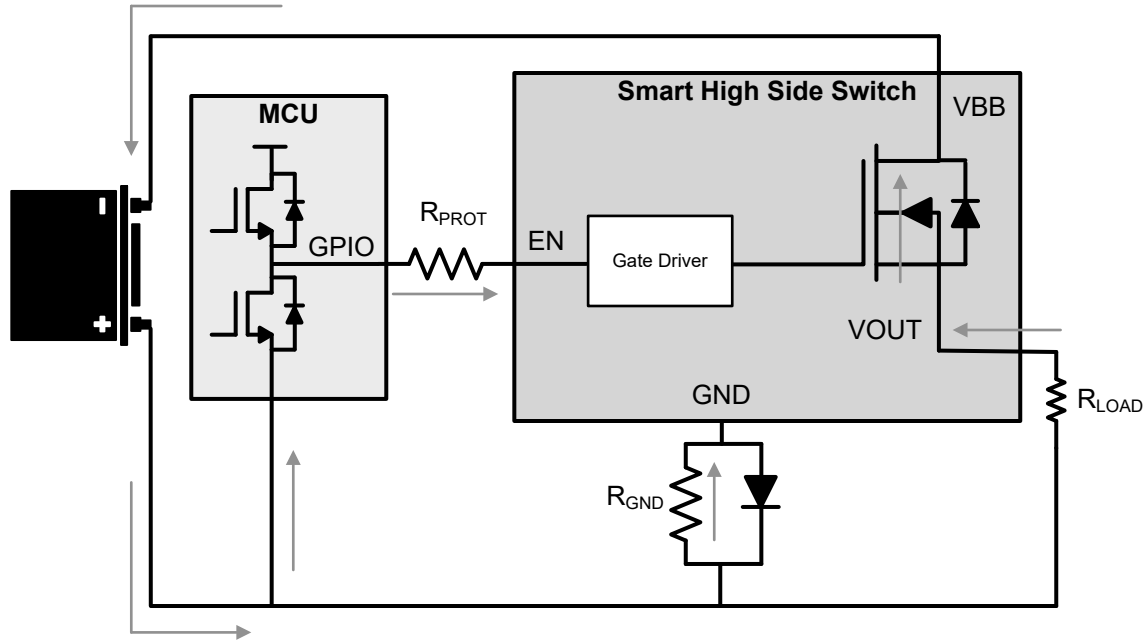

Figure 7-16. Reverse Battery Circuit

For more external protection circuitry information, see [Section 7.3.8.4](#). See the fault truth table in [Section 7.3.6.4](#) for more details.

### 7.3.7.5 Thermal Fault Detection

To protect the device in severe power stressing cases, the device implements two types of thermal fault detection, absolute temperature protection (absolute thermal shutdown) and dynamic temperature protection (relative thermal shutdown). Respective temperature sensors are integrated close to each power FET, so the thermal fault is reported by each channel. This arrangement can help the device keep the cross-channel effect to a minimum when some channels are in a thermal fault condition.

#### 7.3.7.5.1 Thermal Protection Behavior

The thermal protection behavior can be split up into three categories of events that can happen. [Figure 7-17](#) shows each of these categories.

1. **Relative thermal shutdown:** the device is enabled into an overcurrent event. The output current rises up to the  $I_{LIM}$  level and the  $\overline{FLT}$  goes low. With this large amount of current going through the junction temperature of the FET increases rapidly with respect to the controller temperature. When the power FET temperature rises  $T_{REL}$  amount above the controller junction temperature  $\Delta T = T_{FET} - T_{CON} > T_{REL}$ , the device shuts down. For auto-retry version, after  $t_{RETRY}$ , the part tries to restart itself. Latch version will require EN to be toggled to re-enable the channel. The  $\overline{FLT}$  is asserted until the fault condition is cleared.
2. **Absolute thermal shutdown:** the device is still enabled in an overcurrent event. However, in this case the junction temperature rises up and hits an absolute reference temperature,  $T_{ABS}$ , and then shuts down. For auto-retry version, the device does not recover until both  $T_J < T_{ABS} - T_{hys}$  and the  $t_{RETRY}$  timer has expired. For latch version, toggling EN is required to re-enable the channel.

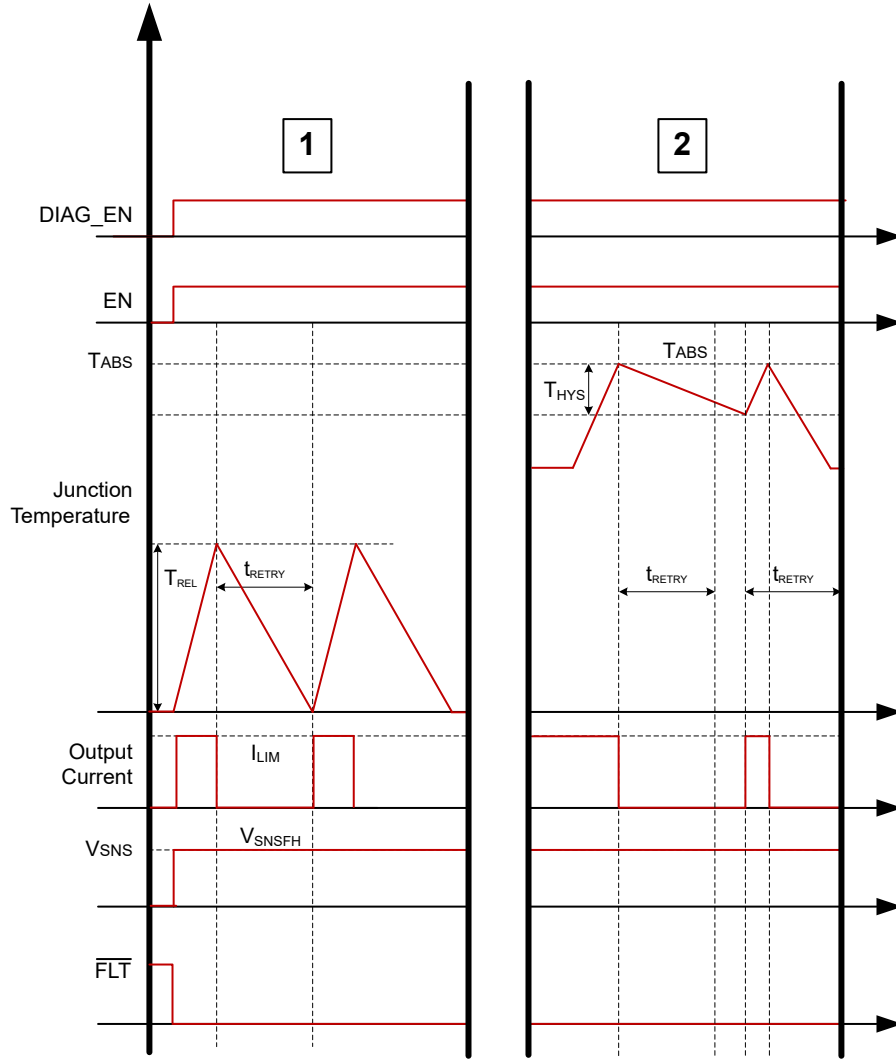

Figure 7-17. Thermal Behavior for Auto-retry Version

### 7.3.8 Full Protections

#### 7.3.8.1 UVLO Protection

The device monitors the supply voltage  $V_{VBB}$ , to prevent unpredicted behaviors when  $V_{VBB}$  is too low. When  $V_{VBB}$  falls down to  $V_{UVLOF}$ , the device shuts down. When  $V_{VBB}$  rises up to  $V_{UVLOR}$ , the device turns on.

#### 7.3.8.2 Loss of GND Protection

When loss of GND occurs, output is turned off regardless of whether the input signal is high or low.

**Case 1 (loss of device/IC GND):** loss of GND protection is active when the thermal pad ( $T_{ab}$ ), IC GND, and current limit ground are one trace connected to the system ground, as shown in [Figure 7-18](#).

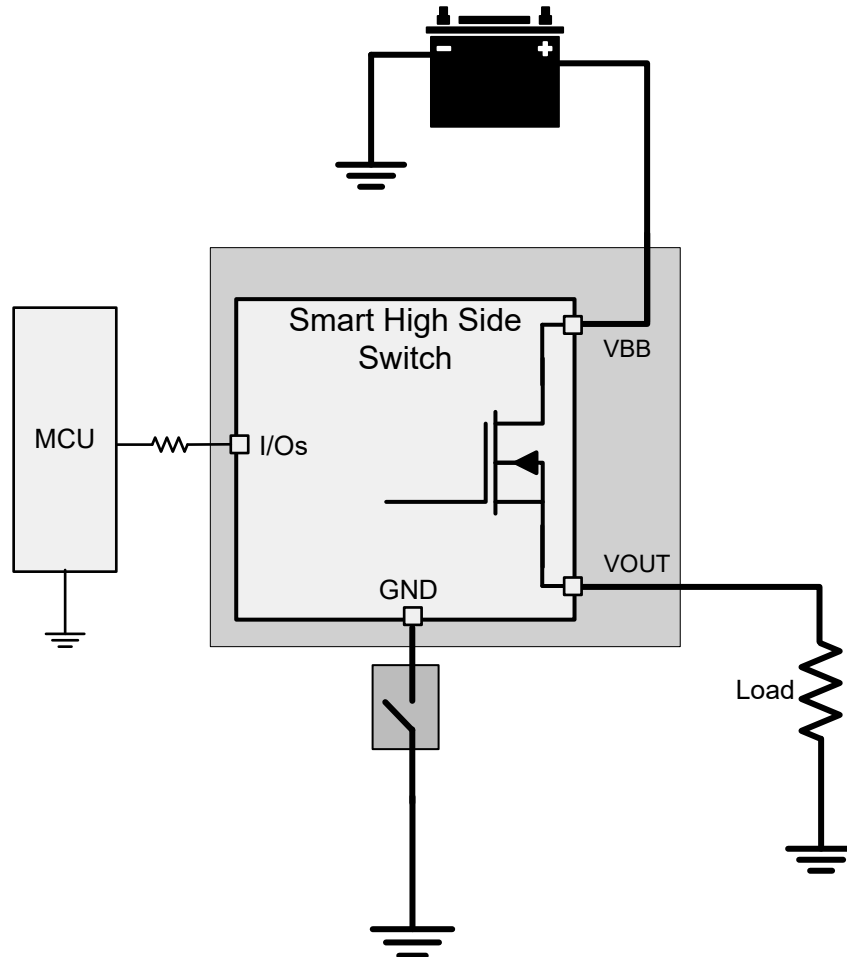

Figure 7-18. Loss of Device GND

**Case 2 (loss of module GND):** when the whole ECU module GND is lost, protections are also active. At this condition, the load GND remains connected.

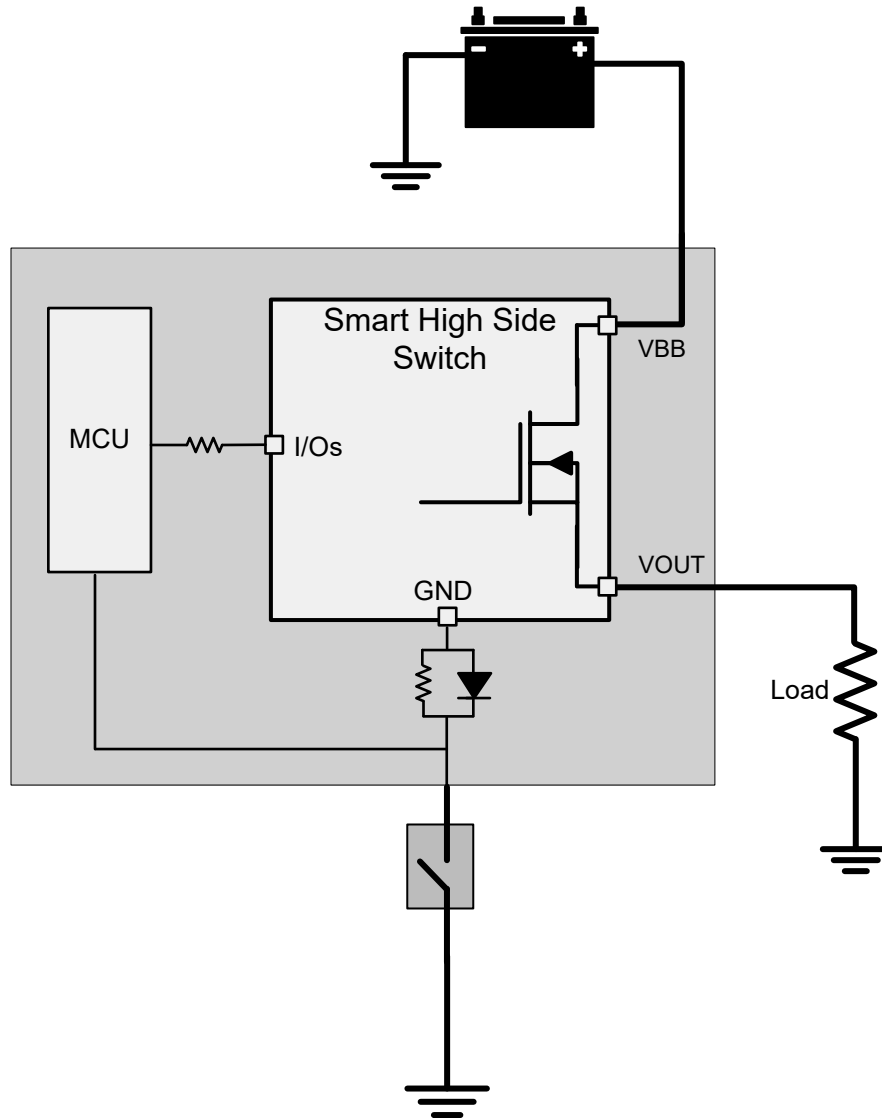

Figure 7-19. Loss of Module GND

### 7.3.8.3 Loss of Power Supply Protection

When loss of supply occurs, output is turned off regardless of whether the input is high or low. For a resistive or capacitive load, loss of supply protection is easy to achieve due to no more power. The worst case is a charged inductive load. In this case, the current is driven from all of the IOs to maintain the inductance output loop. TI recommends either the MCU serial resistor plus the GND network (diode and resistor in parallel) or external free-wheeling circuitry.

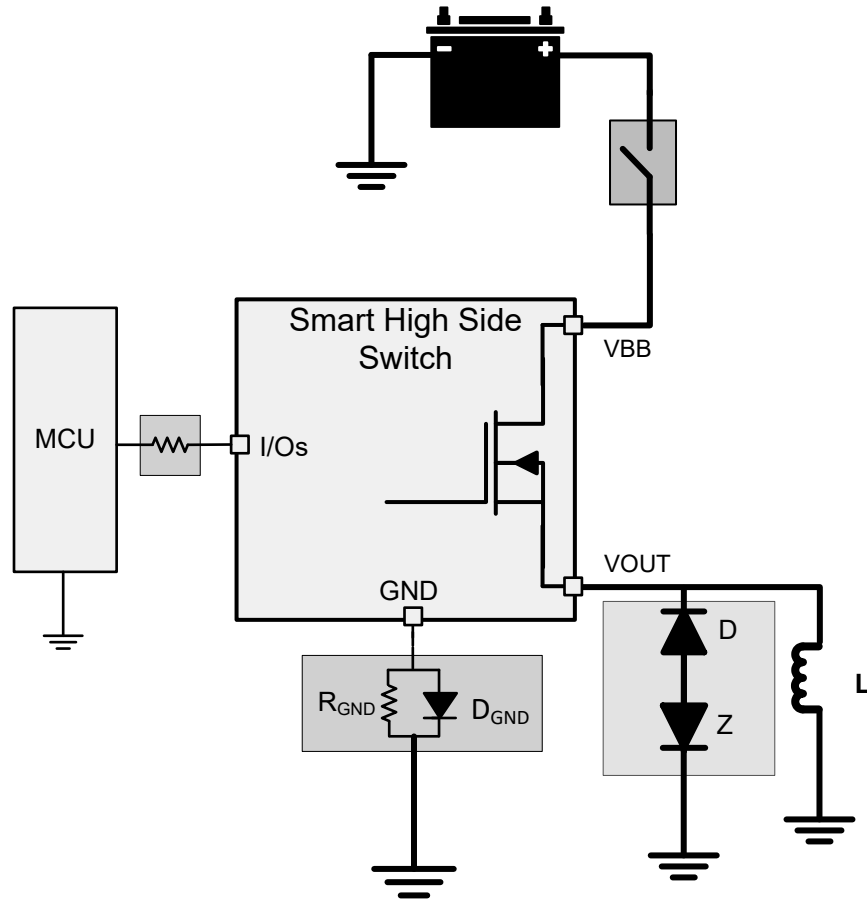
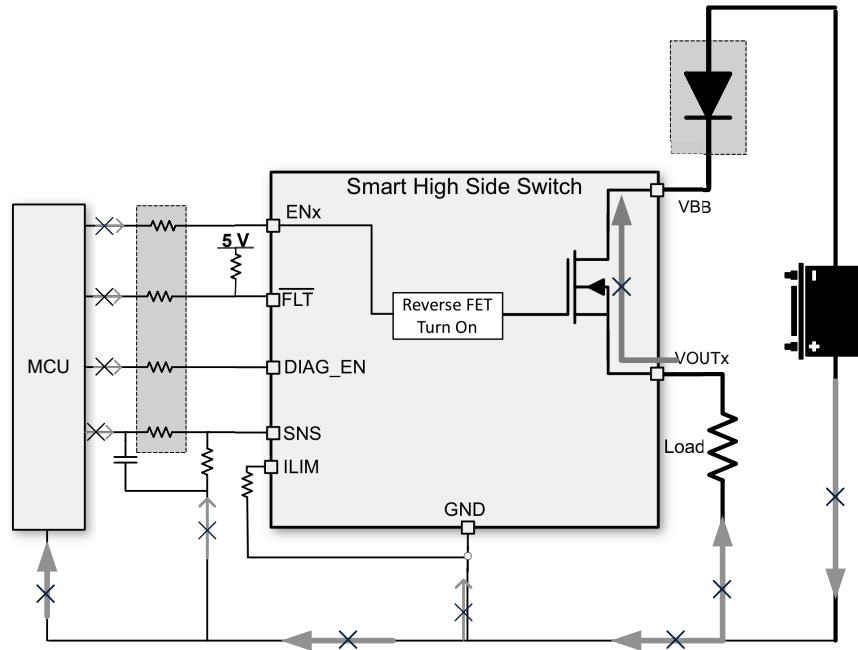

Figure 7-20. Loss of Battery

### 7.3.8.4 Reverse Polarity Protection

**Method 1:** block diode connected with  $V_{BB}$ . Both the device and load are protected when in reverse polarity. The blocking diode does not allow any of the current to flow during reverse battery condition.



**Figure 7-21. Reverse Protection With Block Diode**



**Method 2 (GND network protection):** only the high-side device is protected under this connection. The load reverse current is limited by the impedance of the load itself. Note when reverse polarity happens, the continuous reverse current through the power FET must not make the heat build up be greater than the absolute maximum junction temperature. This can be calculated using the  $R_{ON(REV)}$  value and the  $R_{\theta JA}$  specification. In the reverse battery condition it is important that the FET comes on to lower the power dissipation. This action is achieved through the path from EN to system ground where the positive voltage is being applied. No matter what types of connection are between the device GND and the board GND, if a GND voltage shift happens, ensure the following proper connections for the normal operation:

- Connect the current limit programmable resistor to the device GND.

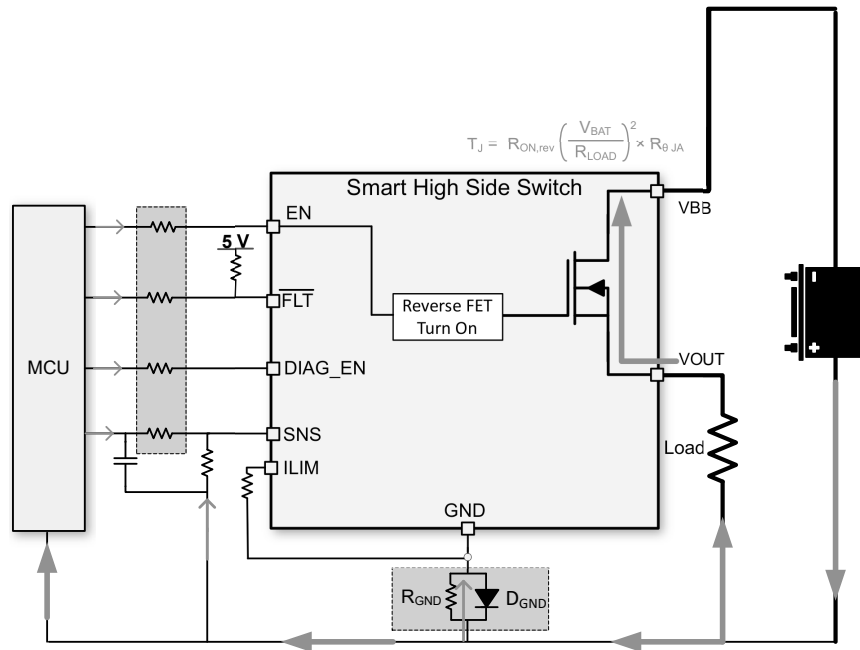

Figure 7-22. Reverse Protection With GND Network

- **Recommendation – resistor and diode in parallel:** a peak negative spike can occur when the inductive load is switching off, which can damage the HSD or the diode. So, TI recommends a resistor in parallel with the diode when driving an inductive load. The recommended selection are a 1kΩ resistor in parallel with an  $I_F > 100\text{mA}$  diode. If multiple high-side switches are used, the resistor and diode can be shared among devices.

If multiple high-side power switches are used, the resistor can be shared among devices.

- **Ground Resistor:** The higher resistor value contributes to a better current limit effect when the reverse battery or negative ISO pulses.

$$R_{GND} \geq \frac{(-V_{CC})}{(-I_{GND})} \quad (6)$$

where

- $-V_{CC}$  is the maximum reverse battery voltage (typically  $-16\text{V}$ ).
- $-I_{GND}$  is the maximum reverse current the ground pin can withstand, which is available in the [Absolute Maximum Ratings](#).
- **Ground Diode:** A diode is needed to block the reverse voltage, which also brings a ground shift ( $\approx 600\text{mV}$ ). Additionally, the diode must be  $\approx 200\text{V}$  reverse voltage for the ISO 7637 pulse 1 testing so that it does not get biased.

### 7.3.8.5 Protection for MCU I/Os

In many conditions, such as the negative ISO pulse, or the loss of battery with an inductive load, a negative potential on the device GND pin can damage the MCU I/O pins (more likely, the internal circuitry connected to the pins). Therefore, the serial resistors between MCU and HSS are required.

Also, for proper protection against loss of GND, TI recommends 10-kΩ resistance for the  $R_{PROT}$  resistors.

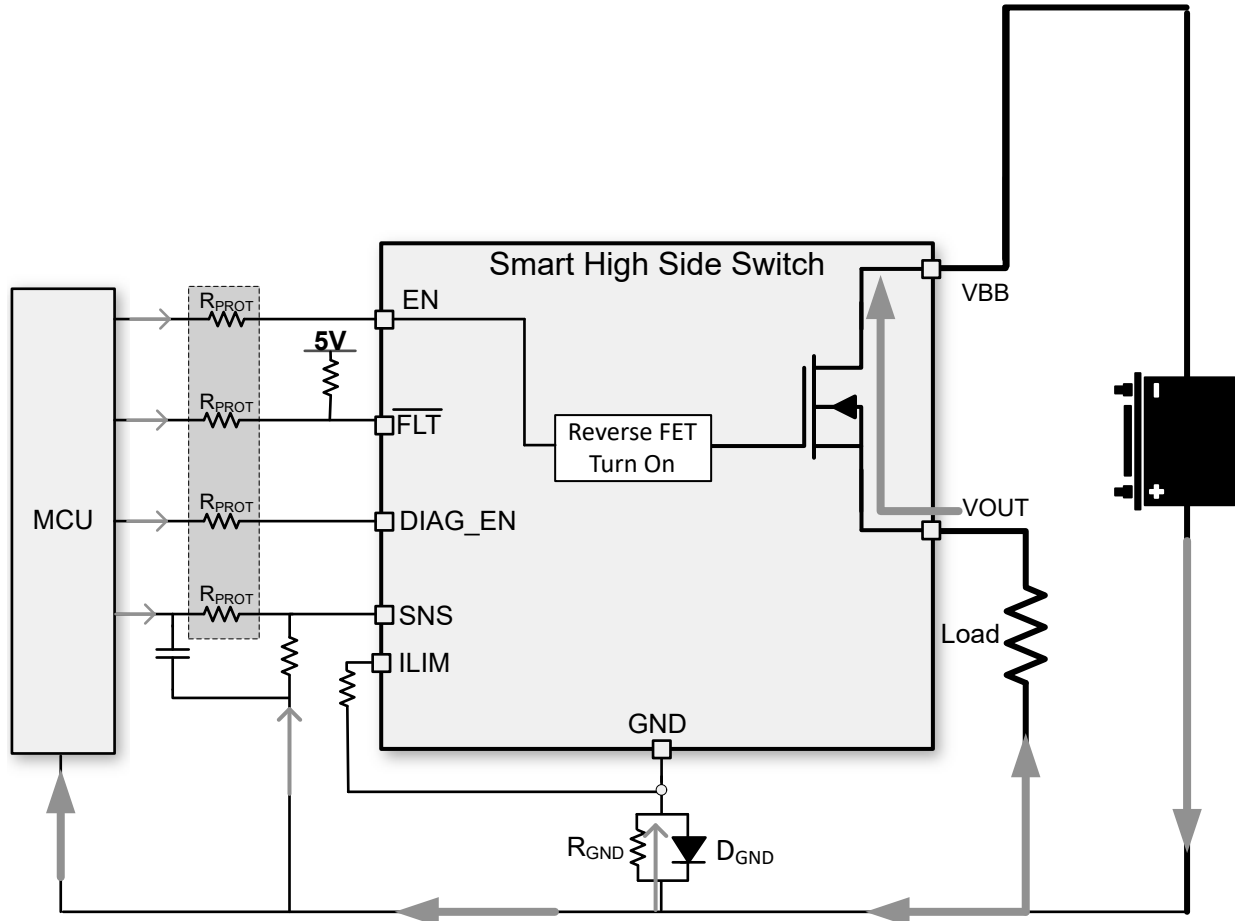

Figure 7-23. MCU I/O Protections

## 7.4 Device Functional Modes

### 7.4.1 Working Mode

This device has several states to transition into based on the ENx pins, DIAG\_EN pin and load conditions.

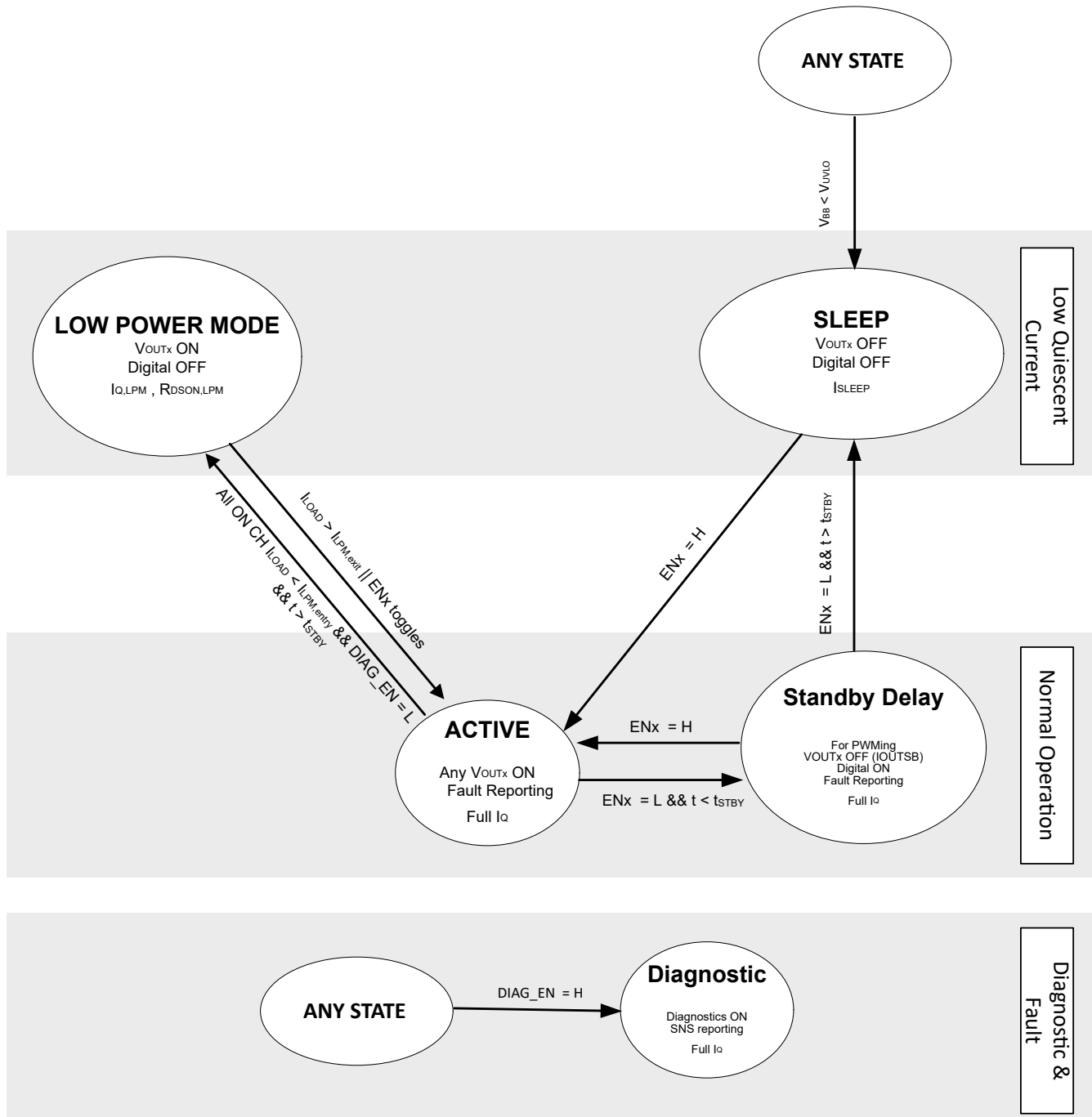

Figure 7-24. State Diagram

## SLEEP

In the SLEEP state, everything inside the device is turned off and the quiescent current is the  $I_{SLEEP}$ . The device can only transition out of the SLEEP state if the ENx pins or DIAG\_EN pin gets pulled high. From SLEEP, the device can transfer into the ACTIVE state if any of the ENx pins are pulled high, or the DIAGNOSTIC state if the DIAG\_EN pin, without any of the ENx pins, goes high. Additionally, if the device is in any of the states and V<sub>BB</sub> drops below  $V_{UVLO}$ , the device transitions into SLEEP state.

## DIAGNOSTIC

The DIAGNOSTIC state is when the device is outputting diagnostics on the SNS and  $\overline{\text{FLT}}$  pins. This can happen when the device is in any previous state and the DIAG\_EN pin goes high. The off-state diagnostics are comprised of open load detection in off state and short to battery detection. The  $\overline{\text{FLT}}$  pin asserts if there is a fault on any of the channels, but the SNS pin only outputs a fault for the channel associated to the SELx pin values. From the DIAGNOSTIC state, the device can transfer into the ACTIVE state if the DIAG\_EN pin goes back low and any channel is on or the STANDBY DELAY state if all channels are OFF.

## ACTIVE

The ACTIVE state is when any of the channel outputs are on by the ENx pin associated. In the ACTIVE state, the current limit value is set by the external resistor on the ILIM pin. If the DIAG\_EN pin is pulled high while in the ACTIVE state, the SNS pin outputs a proportional current to the load current of the channel associated to the SELx pins configuration until a fault occurs on that channel. Additionally the  $\overline{\text{FLT}}$  pin reports if there is a fault occurring on any channel. The device can transition out of the ACTIVE state by turning off all of the channels while DIAG\_EN is high or low, or a fault occurring. If all of the channels turn off and DIAG\_EN is high, the device transitions into the DIAGNOSTIC state. If all of the channels turn off and the DIAG\_EN pin is low, then the device transfers into the STANDBY DELAY state.

## STANDBY DELAY

The STANDBY DELAY state is when the ENx pins are all low, outputs are all turned off and the DIAG\_EN pin is also low but there has not yet been  $t_{\text{STBY}}$  amount of time. This state is included so that the channel outputs can be PWM'd without all of the internal rails being cut off and put to SLEEP mode. Once the device has waited  $t_{\text{STBY}}$ , the device completely shuts down and transitions into SLEEP. However, if during  $t_{\text{STBY}}$ , ENx were to go high, the device transitions into ACTIVE without shutting completely down. Similarly if the DIAG\_EN goes high, the device transitions into DIAGNOSTIC.

## LOW POWER MODE

The LOW POWER MODE state is when the channels that are active are below the  $I_{\text{LPM,entry}}$  level for longer than  $t_{\text{STBY}}$  and the DIAG\_EN is low. The device turns off all unnecessary internal blocks and reduces the quiescent current from  $I_{\text{Q}}$  to  $I_{\text{Q,LPM}}$ . The device is still protected but no diagnostics or fault reporting is possible until device comes out of this mode. For more information on Low Power Mode see [Section 7.3.2](#).

## 8 Application and Implementation

### Note

Information in the following applications sections is not part of the TI component specification, and TI does not warrant its accuracy or completeness. TI's customers are responsible for determining suitability of components for their purposes, as well as validating and testing their design implementation to confirm system functionality.

### 8.1 Application Information

The TPS4HC120-Q1 device is capable of driving a wide variety of resistive, inductive, and capacitive loads, including the low-wattage bulbs, LEDs, relays, solenoids, heaters, and sub-modules. Full diagnostics and high-accuracy current-sense features enable intelligent control of the load. An external adjustable current limit improves the reliability of the whole system by clamping the inrush or overload current.

### 8.2 Typical Application

Figure 8-1 shows an example of the external circuitry connections for TPS4HC120.

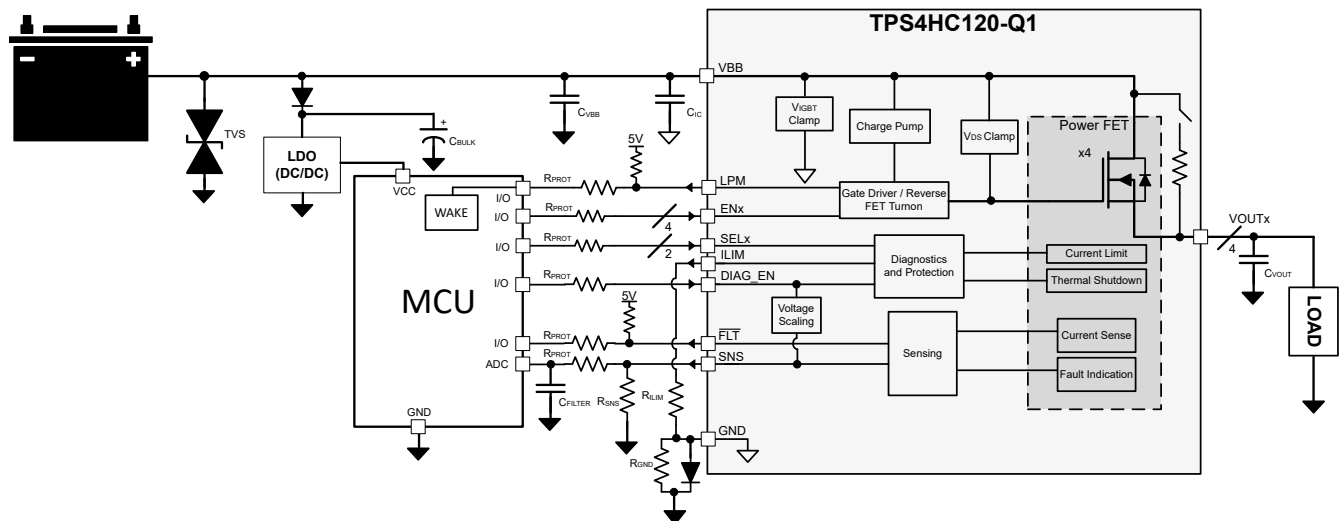

Figure 8-1. Typical Application Diagram

Table 8-1. Recommended Component Values

| COMPONENT    | DESCRIPTION                            | PURPOSE   |
|--------------|--|---|
| TVS          | SMBJ39CA                               | Filter voltage transients coming from battery (ISO7637-2)   |
| $C_{VBB}$    | 220nF                                  | Better EMI performance  |
| $C_{IC}$     | 100nF                                  | Minimal amount of capacitance on input for EMI mitigation   |
| $C_{BULK}$   | 10 $\mu$ F                             | Help filter voltage transients on the supply rail   |
| $R_{PROT}$   | 10k $\Omega$                           | Protection resistor for microcontroller and device I/O pins   |
| $R_{LIM}$    | Discrete values as listed in Table 7-1 | Set current limit threshold   |
| $R_{SNS}$    | 1k $\Omega$                            | Translate the sense current into sense voltage  |
| $C_{FILTER}$ | 100nF                                  | Coupled with $R_{PROT}$ on the SNS line creates a low pass filter to filter out noise going into the ADC of the MCU |
| $C_{VOUT}$   | 22nF                                   | Improves EMI performance, filtering of voltage transients   |
| $R_{PULLUP}$ | 5k $\Omega$                            | Pull up resistor for open-drain pins ( $\overline{FLT}$ and LPM)  |
| $R_{GND}$    | 1k $\Omega$                            | Stabilize GND potential during turn-off of inductive load   |

**Table 8-1. Recommended Component Values (continued)**

| COMPONENT        | DESCRIPTION | PURPOSE  |
|------------------|-------------|--|
| D <sub>GND</sub> | BAS21 Diode | Keeps GND close to system ground during normal operation |

**8.2.1 Design Requirements**

**Table 8-2. Example Design Requirements**

| PARAMETER             | VALUE |
|-----------------------|-------|
| V <sub>DIAG_EN</sub>  | 5V    |
| I <sub>LOAD,max</sub> | 1A    |
| I <sub>LOAD,min</sub> | 10mA  |
| V <sub>ADC,min</sub>  | 5mV   |
| V <sub>HR</sub>       | 1V    |

**8.2.2 Detailed Design Procedure**

To keep the 1A nominal current in the 0V to 4V current-sense range, calculate the R<sub>(SNS)</sub> resistor using Equation 7. To achieve better current-sense accuracy, a 1% tolerance or better resistor is preferred.

$$V_{ADC,min} \times K_{SNS} / I_{LOAD,min} \leq R_{SNS} \leq (V_{SNSFH} - V_{HR}) \times K_{SNS} / I_{LOAD,max} \tag{7}$$

The design requirement listed in Table 8-2 yields  $520\Omega \leq R_{SNS} \leq 4160\Omega$ , and 1kΩ R<sub>SNS</sub> satisfies the requirements.

To set the adjustable current limit value, use the R<sub>(ILIM)</sub> recommended in the Current Limit Table. In this application, to leave enough margin for the current transient and ripple, a 9.76kΩ R<sub>ILIM</sub> resistor satisfies the requirements.

**8.2.3 Application Curves**

Figure 8-2 shows a test example of soft-start when driving a big capacitive load. Figure 8-3 shows the VDS clamp engaging during inductive load discharge.

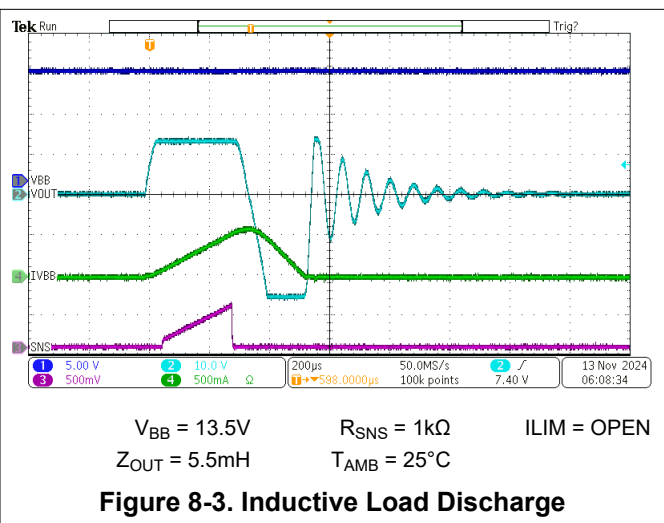
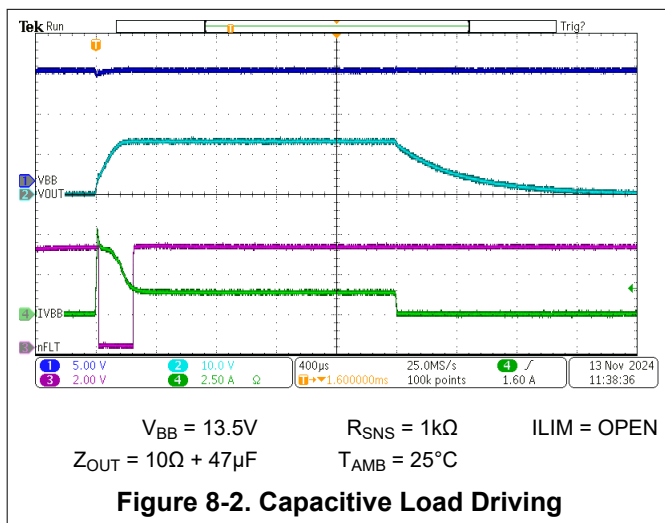

**8.3 EMC Transient Disturbances Test**

Due to the severe electrical conditions in the automotive environment, immunity capacity against electrical transient disturbances is required, especially for a high side power switch, which is connected directly to the battery. Detailed test requirements are in accordance with the ISO 7637-2:2011 and ISO 16750-2:2010 standards.

**Table 8-3. ISO 7637-2:2011(E) in 12V System** <sup>(1) (2) (3)</sup>

| Test Item | Test Pulse Severity Level and vs Accordingly |      | Pulse Duration ( $t_d$ ) | Minimum Number of Pulses or Test Time | Burst-Cycle Pulse-Repetition Time |       | Input Resistance ( $\Omega$ ) | Function Performance Status Classification |
|-----------|--|------|--------------------------|---------------------------------------|-----------------------------------|-------|-------------------------------|--|
|           | Level  | Vs/V |                          |                                       | MIN                               | MAX   |                               |  |
| 1         | III  | -112 | 2ms                      | 500 pulses                            | 0.5s                              | —     | 10                            | Status II                                  |
| 2a        | III  | 55   | 50 $\mu$ s               | 500 pulses                            | 0.2s                              | 5s    | 2                             | Status II                                  |
| 2b        | IV   | 10   | 0.2s to 2s               | 10 pulses                             | 0.5s                              | 5s    | 0 to 0.05                     | Status II                                  |
| 3a        | IV   | -220 | 0.1 $\mu$ s              | 1h                                    | 90ms                              | 100ms | 50                            | Status II                                  |
| 3b        | IV   | 150  | 0.1 $\mu$ s              | 1h                                    | 90ms                              | 100ms | 50                            | Status II                                  |

- (1) Tested both under input low condition and high condition.  
(2) GND pin network is a 1k $\Omega$  resistor in parallel with a diode BAS21-7-F.  
(3) Status II: The function does not perform as designed during the test, but returns automatically to normal operation after the test.

**Table 8-4. ISO 16750-2:2010(E) Load Dump Test B in 12V System** <sup>(1) (2) (3) (4)</sup>

| Test Item | Test Pulse Severity Level and vs Accordingly |      | Pulse Duration ( $t_d$ ) | Minimum Number of Pulses or Test Time | Burst-Cycle Pulse-Repetition Time | Input Resistance ( $\Omega$ ) | Function Performance Status Classification |
|-----------|--|------|--------------------------|---------------------------------------|-----------------------------------|-------------------------------|--|
|           | Level  | Vs/V |                          |                                       |                                   |                               |  |
| Test B    |  | 35   | 40ms to 400ms            | 5 pulses                              | 60s                               | 0.5 to 4                      | Status II                                  |

- (1) Tested both under input low condition and high condition (DIAG\_EN, ENx, and VBB are all classified as inputs).  
(2) Considering the worst test condition, the device is tested without any filter capacitors on VBB and VOUTx.  
(3) The GND pin network is a 1k $\Omega$  resistor in parallel with a diode BAS21-7-F.  
(4) Status II: The function does not perform as designed during the test, but returns automatically to normal operation after the test.

## 8.4 Power Supply Recommendations

The device is qualified for both automotive and industrial applications. The normal power supply connection is a 12V automotive system. The supply voltage must be within the range specified in the [Recommended Operating Conditions](#).

**Table 8-5. Voltage Operating Ranges**

| VBB VOLTAGE RANGE | NOTE  |
|-------------------|---|
| 3V to 6V          | Extended lower 12V automotive battery operation such as cold crank and start-stop. Device is fully functional and protected but some parametrics such as $R_{ON}$ , current sense accuracy, current limit accuracy and timing parameters can deviate from specifications. Check the individual specifications in <a href="#">Section 6.5</a> to confirm the voltage range it is applicable for. |
| 6V to 18V         | Nominal 12V automotive battery voltage range. All parametric specifications apply and the device is fully functional and protected.   |
| 18V to 24V        | Extended upper 12V automotive battery operation such as double battery. Device is fully functional and protected but some parametrics such as $R_{ON}$ , current sense accuracy, current limit accuracy, and timing parameters can deviate from specifications. Check the individual specifications in <a href="#">Section 6.5</a> to confirm the voltage range it is applicable for.           |
| 35V               | Load dump voltage. Device is operational and lets the pulse pass through without being damaged but does not protect against short circuits.   |

## 8.5 Layout

### 8.5.1 Layout Guidelines

To prevent thermal shutdown,  $T_J$  must be less than 150°C. The HTSSOP package has good thermal impedance. However, the PCB layout is very important. Good PCB design can optimize heat transfer, which is absolutely essential for the long-term reliability of the device.

- Maximize the copper coverage on the PCB to increase the thermal conductivity of the board. The major heat flow path from the package to the ambient is through the copper on the PCB. Maximum copper is extremely important when there are not any heat sinks attached to the PCB on the other side of the package.

- Add as many thermal vias as possible directly under the package ground pad to optimize the thermal conductivity of the board.
- All thermal vias should either be plated shut or plugged and capped on both sides of the board to prevent solder voids. To ensure reliability and performance, the solder coverage should be at least 85%.

### 8.5.2 Layout Examples

#### 8.5.2.1 Without a GND Network

Without a GND network, tie the thermal pad directly to the board GND copper for better thermal performance.

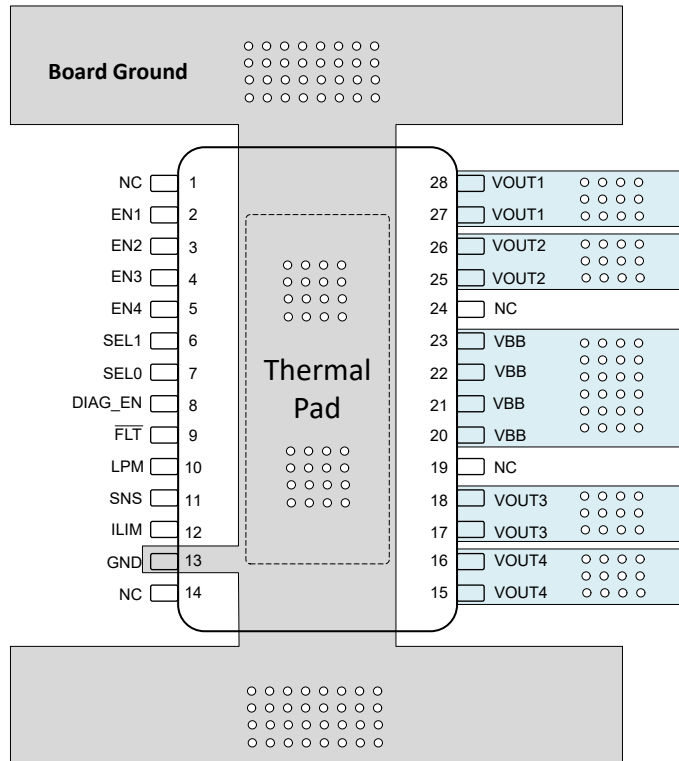
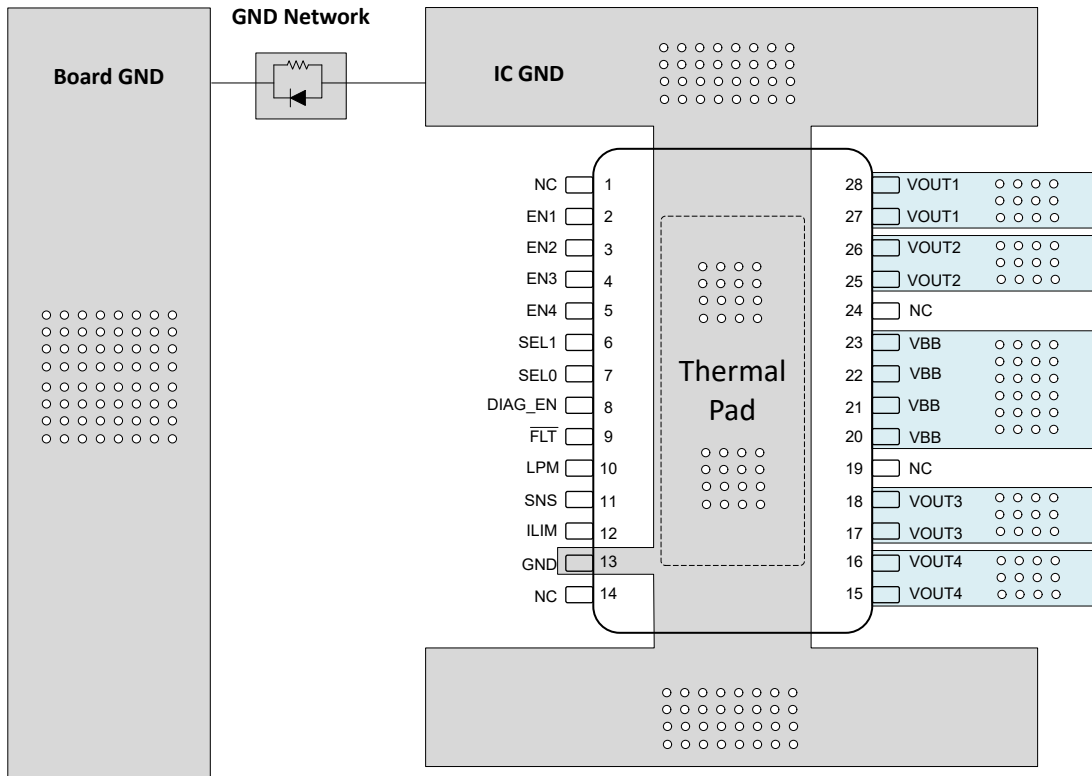

Figure 8-4. Layout Example Without a GND Network



### 8.5.2.2 With a GND Network

With a GND network, tie the thermal pad with a single trace through the GND network to the board GND copper. Have more IC GND coverage to get better thermal performance of the part.



**Figure 8-5. Layout Example With a GND Network**

## 9 Device and Documentation Support

### 9.1 Receiving Notification of Documentation Updates

To receive notification of documentation updates, navigate to the device product folder on [ti.com](https://www.ti.com). Click on *Notifications* to register and receive a weekly digest of any product information that has changed. For change details, review the revision history included in any revised document.

### 9.2 Support Resources

[TI E2E™ support forums](#) are an engineer's go-to source for fast, verified answers and design help — straight from the experts. Search existing answers or ask your own question to get the quick design help you need.

Linked content is provided "AS IS" by the respective contributors. They do not constitute TI specifications and do not necessarily reflect TI's views; see TI's [Terms of Use](#).

### 9.3 Trademarks

TI E2E™ is a trademark of Texas Instruments.  
All trademarks are the property of their respective owners.

### 9.4 Electrostatic Discharge Caution



This integrated circuit can be damaged by ESD. Texas Instruments recommends that all integrated circuits be handled with appropriate precautions. Failure to observe proper handling and installation procedures can cause damage.

ESD damage can range from subtle performance degradation to complete device failure. Precision integrated circuits may be more susceptible to damage because very small parametric changes could cause the device not to meet its published specifications.

### 9.5 Glossary

[TI Glossary](#) This glossary lists and explains terms, acronyms, and definitions.

## 10 Revision History

NOTE: Page numbers for previous revisions may differ from page numbers in the current version.

| Changes from Revision * (December 2024) to Revision A (January 2025)          | Page |
|---|------|
| • Added the device comparison table.....                                      | 3    |
| • Updated to show LPM pin added.....  | 15   |
| • Added description for both auto-retry and latch versions.....               | 20   |
| • FLT now reports regardless of DIAG_EN.....                                  | 23   |
| • FLT now reports regardless of DIAG_EN.....                                  | 24   |
| • Updated the table to add description for auto-retry and latch versions..... | 24   |

## 11 Mechanical, Packaging, and Orderable Information

The following pages include mechanical, packaging, and orderable information. This information is the most-current data available for the designated device. This data is subject to change without notice and without revision of this document. For browser-based versions of this data sheet, see the left-hand navigation pane.

**PACKAGING INFORMATION**

| Orderable Device  | Status<br>(1) | Package Type | Package Drawing | Pins | Package Qty | Eco Plan<br>(2) | Lead finish/<br>Ball material<br>(6) | MSL Peak Temp<br>(3) | Op Temp (°C) | Device Marking<br>(4/5) | Samples |
|-------------------|---------------|--------------|-----------------|------|-------------|-----------------|--------------------------------------|----------------------|--------------|-------------------------|---------|
| TPS4HC120AQDGQRQ1 | ACTIVE        | HVSSOP       | DGQ             | 28   | 2500        | RoHS & Green    | NIPDAU                               | Level-3-260C-168 HR  | -40 to 125   | 4HC120A                 | Samples |

(1) The marketing status values are defined as follows:

**ACTIVE:** Product device recommended for new designs.

**LIFEBUY:** TI has announced that the device will be discontinued, and a lifetime-buy period is in effect.

**NRND:** Not recommended for new designs. Device is in production to support existing customers, but TI does not recommend using this part in a new design.

**PREVIEW:** Device has been announced but is not in production. Samples may or may not be available.

**OBSELETE:** TI has discontinued the production of the device.

(2) **RoHS:** TI defines "RoHS" to mean semiconductor products that are compliant with the current EU RoHS requirements for all 10 RoHS substances, including the requirement that RoHS substance do not exceed 0.1% by weight in homogeneous materials. Where designed to be soldered at high temperatures, "RoHS" products are suitable for use in specified lead-free processes. TI may reference these types of products as "Pb-Free".

**RoHS Exempt:** TI defines "RoHS Exempt" to mean products that contain lead but are compliant with EU RoHS pursuant to a specific EU RoHS exemption.

**Green:** TI defines "Green" to mean the content of Chlorine (Cl) and Bromine (Br) based flame retardants meet JS709B low halogen requirements of <=1000ppm threshold. Antimony trioxide based flame retardants must also meet the <=1000ppm threshold requirement.

(3) MSL, Peak Temp. - The Moisture Sensitivity Level rating according to the JEDEC industry standard classifications, and peak solder temperature.

(4) There may be additional marking, which relates to the logo, the lot trace code information, or the environmental category on the device.

(5) Multiple Device Markings will be inside parentheses. Only one Device Marking contained in parentheses and separated by a "~" will appear on a device. If a line is indented then it is a continuation of the previous line and the two combined represent the entire Device Marking for that device.

(6) Lead finish/Ball material - Orderable Devices may have multiple material finish options. Finish options are separated by a vertical ruled line. Lead finish/Ball material values may wrap to two lines if the finish value exceeds the maximum column width.

**Important Information and Disclaimer:**The information provided on this page represents TI's knowledge and belief as of the date that it is provided. TI bases its knowledge and belief on information provided by third parties, and makes no representation or warranty as to the accuracy of such information. Efforts are underway to better integrate information from third parties. TI has taken and continues to take reasonable steps to provide representative and accurate information but may not have conducted destructive testing or chemical analysis on incoming materials and chemicals. TI and TI suppliers consider certain information to be proprietary, and thus CAS numbers and other limited information may not be available for release.

In no event shall TI's liability arising out of such information exceed the total purchase price of the TI part(s) at issue in this document sold by TI to Customer on an annual basis.

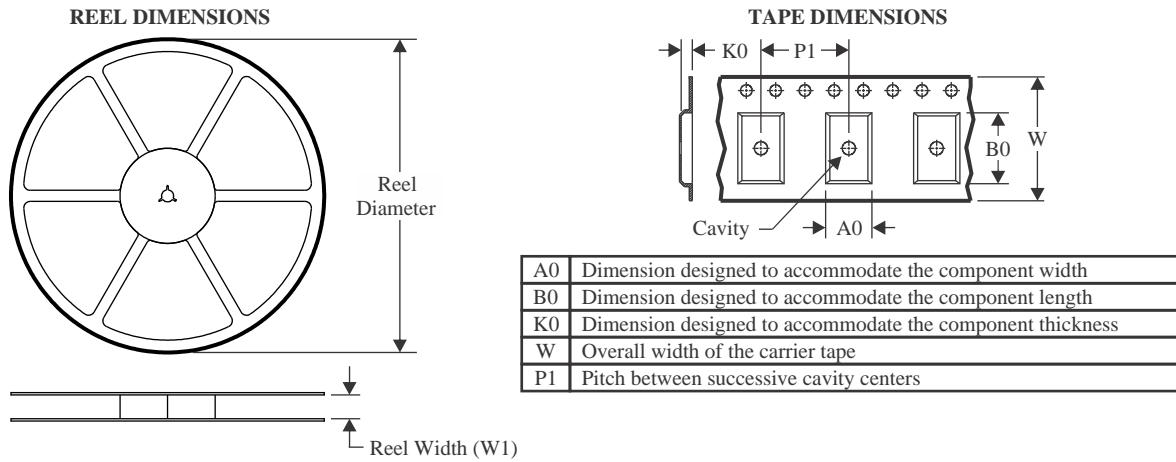
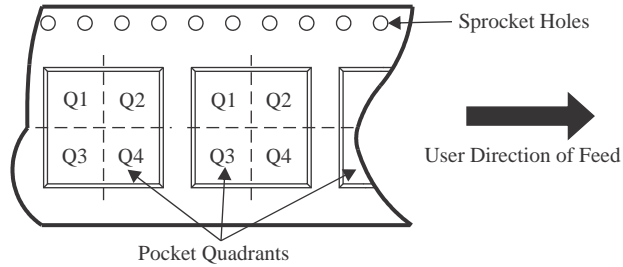
**TAPE AND REEL INFORMATION**

**QUADRANT ASSIGNMENTS FOR PIN 1 ORIENTATION IN TAPE**

\*All dimensions are nominal

| Device            | Package Type | Package Drawing | Pins | SPQ  | Reel Diameter (mm) | Reel Width W1 (mm) | A0 (mm) | B0 (mm) | K0 (mm) | P1 (mm) | W (mm) | Pin1 Quadrant |
|-------------------|--------------|-----------------|------|------|--------------------|--------------------|---------|---------|---------|---------|--------|---------------|
| TPS4HC120AQDGQRQ1 | HVSSOP       | DGQ             | 28   | 2500 | 330.0              | 16.4               | 5.5     | 7.4     | 1.45    | 8.0     | 16.0   | Q1            |

**TAPE AND REEL BOX DIMENSIONS**

\*All dimensions are nominal

| Device            | Package Type | Package Drawing | Pins | SPQ  | Length (mm) | Width (mm) | Height (mm) |
|-------------------|--------------|-----------------|------|------|-------------|------------|-------------|
| TPS4HC120AQDGQRQ1 | HVSSOP       | DGQ             | 28   | 2500 | 353.0       | 353.0      | 32.0        |

## GENERIC PACKAGE VIEW

**DGQ 28**

**HVSSOP - 1.1 mm max height**

3 x 7.1, 0.5 mm pitch

SMALL OUTLINE PACKAGE

This image is a representation of the package family, actual package may vary.  
Refer to the product data sheet for package details.

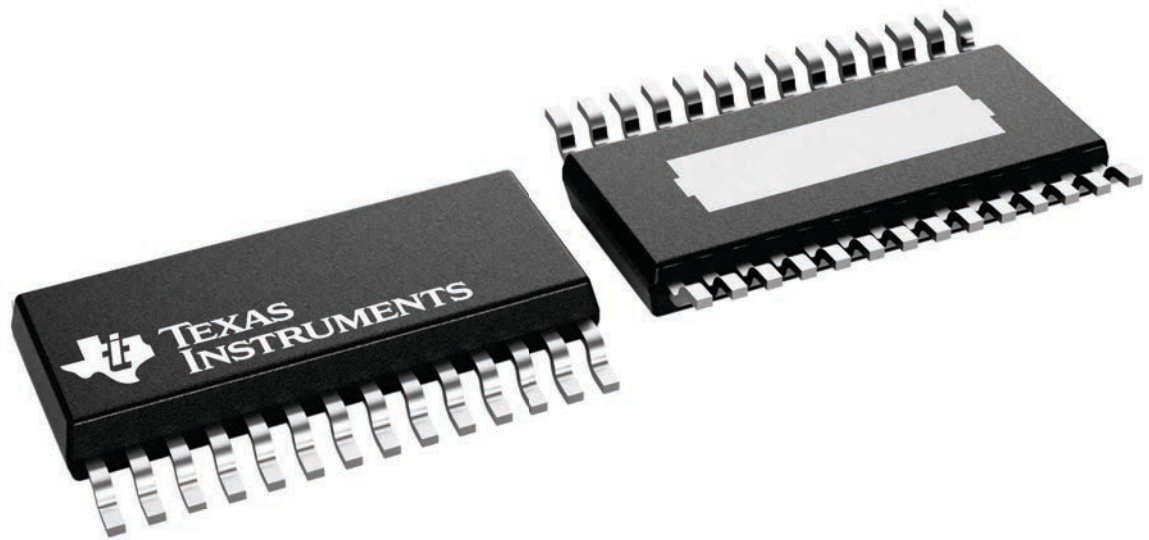

4226530/A

## IMPORTANT NOTICE AND DISCLAIMER

TI PROVIDES TECHNICAL AND RELIABILITY DATA (INCLUDING DATA SHEETS), DESIGN RESOURCES (INCLUDING REFERENCE DESIGNS), APPLICATION OR OTHER DESIGN ADVICE, WEB TOOLS, SAFETY INFORMATION, AND OTHER RESOURCES "AS IS" AND WITH ALL FAULTS, AND DISCLAIMS ALL WARRANTIES, EXPRESS AND IMPLIED, INCLUDING WITHOUT LIMITATION ANY IMPLIED WARRANTIES OF MERCHANTABILITY, FITNESS FOR A PARTICULAR PURPOSE OR NON-INFRINGEMENT OF THIRD PARTY INTELLECTUAL PROPERTY RIGHTS.

These resources are intended for skilled developers designing with TI products. You are solely responsible for (1) selecting the appropriate TI products for your application, (2) designing, validating and testing your application, and (3) ensuring your application meets applicable standards, and any other safety, security, regulatory or other requirements.

These resources are subject to change without notice. TI grants you permission to use these resources only for development of an application that uses the TI products described in the resource. Other reproduction and display of these resources is prohibited. No license is granted to any other TI intellectual property right or to any third party intellectual property right. TI disclaims responsibility for, and you will fully indemnify TI and its representatives against, any claims, damages, costs, losses, and liabilities arising out of your use of these resources.

TI's products are provided subject to [TI's Terms of Sale](#) or other applicable terms available either on [ti.com](https://www.ti.com) or provided in conjunction with such TI products. TI's provision of these resources does not expand or otherwise alter TI's applicable warranties or warranty disclaimers for TI products.

TI objects to and rejects any additional or different terms you may have proposed.

Mailing Address: Texas Instruments, Post Office Box 655303, Dallas, Texas 75265

Copyright © 2025, Texas Instruments Incorporated