

# TPS6287Cxx 2.8V to 6V Input, up to 50A, Stackable Step-Down Converters With I<sup>2</sup>C Interface and Telemetry

## 1 Features

- Input voltage range: 2.8V to 6V
- Output voltage accuracy:  $\pm 0.5\%$
- Output voltage range from 0.4V to 1.0V
- Internal power MOSFETs: 1.8m $\Omega$  and 0.7m $\Omega$
- External compensation
- Optional stacked operation for increased output current capability
- Adjustable switching frequency from 833kHz to 3MHz
- External synchronization
- Forced PWM or power save mode operation
- Optimized load transient operation
- Fixed frequency DCS-Control
- Transient non-synchronous mode
- Adjustable droop compensation
- Optimized for small and low-profile inductors
- I<sup>2</sup>C-compatible interface with up to 3.4MHz
- Differential remote sense
- Thermal pre-warning and thermal shutdown
- Input and output overvoltage protection
- Output discharge
- Optional spread spectrum clocking
- Telemetry for  $V_{IN}$ , Temp,  $V_{OUT}$ , and  $I_{OUT}$
- Interrupt output
- Power-good output with window comparator with adjustable thresholds
- Available in 5.0mm  $\times$  6.0mm, VQFN package

## 2 Applications

- [FPGA, ASIC, and digital core supply](#)
- [Optical networks](#)
- [Storage](#)

## 3 Description

The TPS6287Cxx devices are a family of pin-to-pin, up to 50A synchronous step-down DC/DC converters with I<sup>2</sup>C interface and differential remote sense. Low-resistance power switches allow up to 50A continuous output current at high ambient temperatures. The devices can operate in stacked mode to deliver higher output currents or to spread the power dissipation across multiple devices. In stacked operation, the converters frequencies are synchronized, share a common compensation signal and shift the phases to supply loads with several hundreds of amperes. The TPS6287Cxx family implements a fixed-frequency-DCS-Control scheme with adjustable switching frequency and adjustable loop compensation. The high switching frequency and loop bandwidth is optimized for low-profile- and small-size inductors and low output capacitance. Devices can operate in power-save mode (PSM) for maximum efficiency, or forced-PWM mode for best transient performance and lowest output voltage ripple. The I<sup>2</sup>C compatible interface offers several control, monitoring, and warning features including telemetry data of input voltage, output voltage, output current, and temperature. Four SET pins can be used to program default settings before start-up.

### Device Information

PART NUMBER	CURRENT RATING <sup>(1)</sup>	PACKAGE <sup>(2)</sup>	PACKAGE SIZE <sup>(3)</sup>
TPS6287C25 <sup>(4)</sup>	25A	VAA (WQFN-FCRLF, 20)	5mm $\times$ 6mm
TPS6287C40 <sup>(4)</sup>	40A		
TPS6287C50	50A		

- (1) See the [Device Options](#) table.
- (2) For more information, see [Section 7](#).
- (3) The package size (length  $\times$  width) is a nominal value and includes pins, where applicable.
- (4) Preview information (not Advance Information).

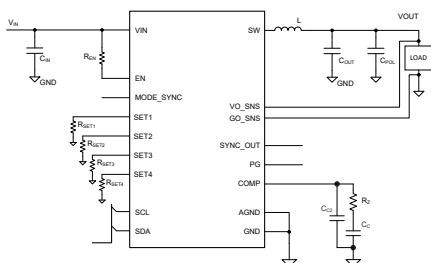

TPS6287Cxx Simplified Schematic

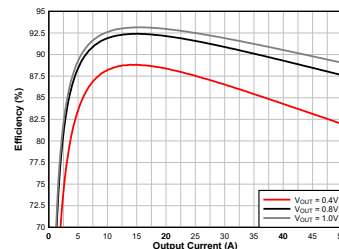

Efficiency TPS6287C50 ( $V_{IN} = 5V$ ;  $F_{SW} = 833kHz$ )



## Table of Contents

<b>1 Features</b> .....	1	5.3 Support Resources.....	4
<b>2 Applications</b> .....	1	5.4 Trademarks.....	4
<b>3 Description</b> .....	1	5.5 Electrostatic Discharge Caution.....	4
<b>4 Device Options</b> .....	3	5.6 Glossary.....	4
<b>5 Device and Documentation Support</b> .....	4	<b>6 Revision History</b> .....	4
5.1 Device Support.....	4	<b>7 Mechanical, Packaging, and Orderable Information</b> ....	5
5.2 Receiving Notification of Documentation Updates.....	4	7.1 Tape and Reel Information.....	5

---

## 4 Device Options

ORDERABLE PART NUMBER	OUTPUT CURRENT	DEFAULT F <sub>sw</sub>
TPS6287C25WVAAR <sup>(1)</sup>	25A	1.0MHz
TPS6287C40WVAAR <sup>(1)</sup>	40A	0.833MHz
TPS6287C50WVAAR	50A	1.5MHz

(1) Preview information (not Advance Information)

**ADVANCE INFORMATION**

## 5 Device and Documentation Support

### 5.1 Device Support

#### 5.1.1 Third-Party Products Disclaimer

TI'S PUBLICATION OF INFORMATION REGARDING THIRD-PARTY PRODUCTS OR SERVICES DOES NOT CONSTITUTE AN ENDORSEMENT REGARDING THE SUITABILITY OF SUCH PRODUCTS OR SERVICES OR A WARRANTY, REPRESENTATION OR ENDORSEMENT OF SUCH PRODUCTS OR SERVICES, EITHER ALONE OR IN COMBINATION WITH ANY TI PRODUCT OR SERVICE.

### 5.2 Receiving Notification of Documentation Updates

To receive notification of documentation updates, navigate to the device product folder on [ti.com](http://ti.com). Click on *Notifications* to register and receive a weekly digest of any product information that has changed. For change details, review the revision history included in any revised document.

### 5.3 Support Resources

[TI E2E™ support forums](#) are an engineer's go-to source for fast, verified answers and design help — straight from the experts. Search existing answers or ask your own question to get the quick design help you need.

Linked content is provided "AS IS" by the respective contributors. They do not constitute TI specifications and do not necessarily reflect TI's views; see TI's [Terms of Use](#).

### 5.4 Trademarks

TI E2E™ is a trademark of Texas Instruments.  
All trademarks are the property of their respective owners.

### 5.5 Electrostatic Discharge Caution



This integrated circuit can be damaged by ESD. Texas Instruments recommends that all integrated circuits be handled with appropriate precautions. Failure to observe proper handling and installation procedures can cause damage.

ESD damage can range from subtle performance degradation to complete device failure. Precision integrated circuits may be more susceptible to damage because very small parametric changes could cause the device not to meet its published specifications.

### 5.6 Glossary

[TI Glossary](#) This glossary lists and explains terms, acronyms, and definitions.

## 6 Revision History

DATE	REVISION	NOTES
March 2026	*	Initial Release

## 7 Mechanical, Packaging, and Orderable Information

The following pages include mechanical, packaging, and orderable information. This information is the most current data available for the designated devices. This data is subject to change without notice and revision of this document. For browser-based versions of this data sheet, refer to the left-hand navigation.

### 7.1 Tape and Reel Information

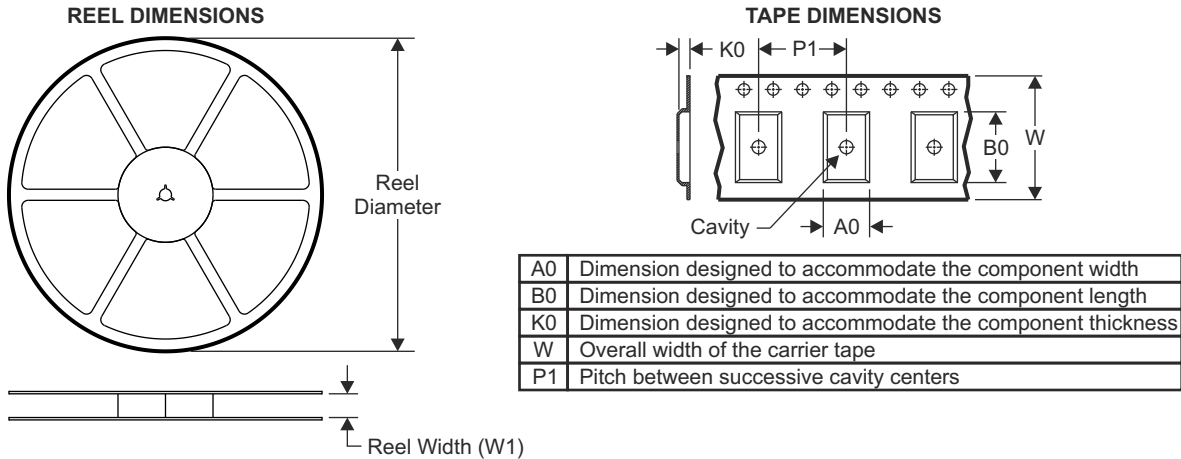

#### QUADRANT ASSIGNMENTS FOR PIN 1 ORIENTATION IN TAPE

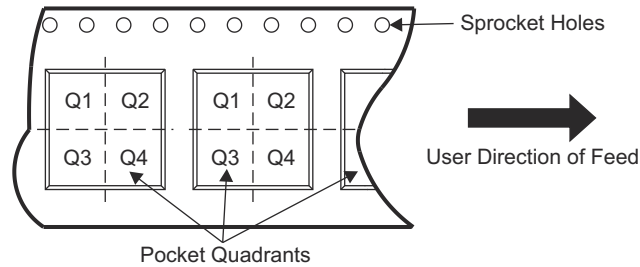

Device	Package Type	Package Drawing	Pins	SPQ	Reel Diameter (mm)	Reel Width W1 (mm)	A0 (mm)	B0 (mm)	K0 (mm)	P1 (mm)	W (mm)	Pin1 Quadrant
TPS6287C50TEWVAAR	WQFN-FCRLF	VAA	20	3000	330.0	12.4	5.25	6.25	0.9	8.0	12.0	Q2
TPS6287C40TAWVAAR	WQFN-FCRLF	VAA	20	3000	330.0	12.4	5.25	6.25	0.9	8.0	12.0	Q2
TPS6287C25TAWVAAR	WQFN-FCRLF	VAA	20	3000	330.0	12.4	5.25	6.25	0.9	8.0	12.0	Q2

**TAPE AND REEL BOX DIMENSIONS**

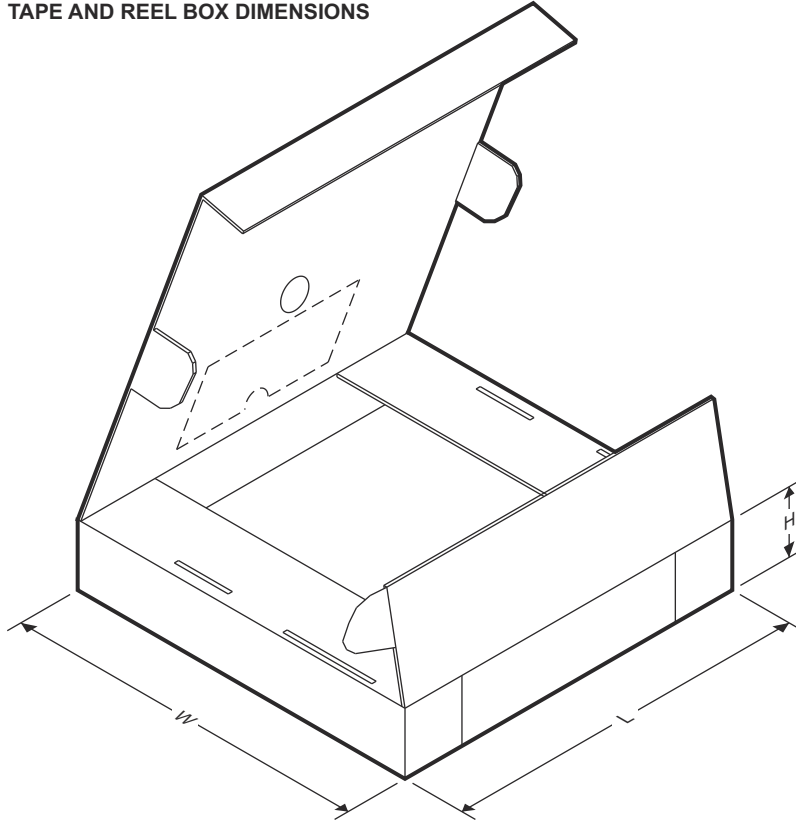

Device	Package Type	Package Drawing	Pins	SPQ	Length (mm)	Width (mm)	Height (mm)
TPS6287C50TEWVAAR	WQFN-FCRLF	VAA	20	3000	367	367	35
TPS6287C40TAWVAAR	WQFN-FCRLF	VAA	20	3000	367	367	35
TPS6287C25TAWVAAR	WQFN-FCRLF	VAA	20	3000	367	367	35

ADVANCE INFORMATION

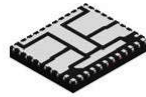

**VAA0020A**

**PACKAGE OUTLINE**  
**WQFN-FCRLF - 0.7 mm max height**

PLASTIC QUAD FLATPACK - NO LEAD

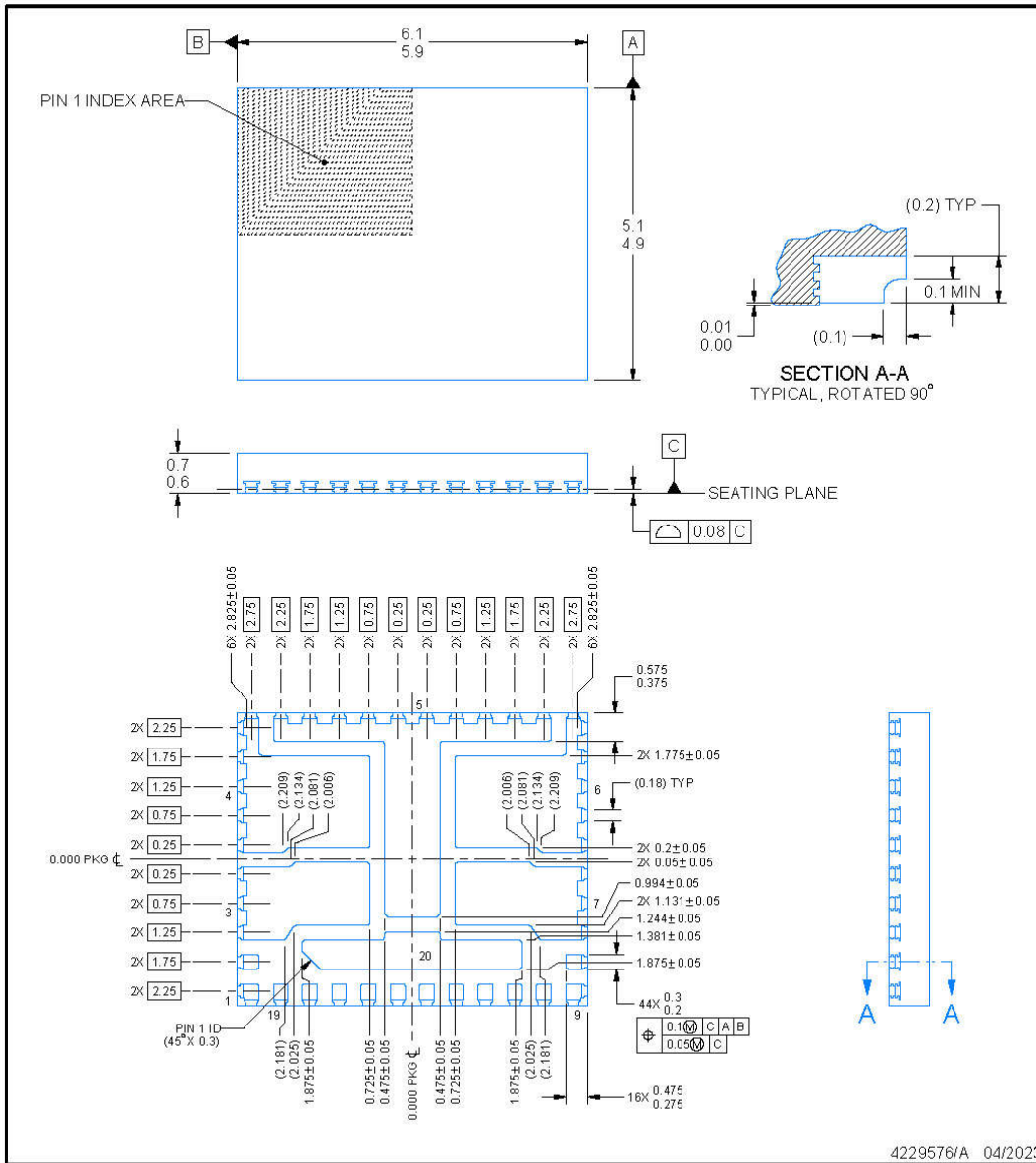

**NOTES:**

1. All linear dimensions are in millimeters. Any dimensions in parenthesis are for reference only. Dimensioning and tolerancing per ASME Y14.5M.
2. This drawing is subject to change without notice.
3. The package thermal pad must be soldered to the printed circuit board for thermal and mechanical performance.

## EXAMPLE BOARD LAYOUT

VAA0020A

WQFN-FCRLF - 0.7 mm max height

PLASTIC QUAD FLATPACK - NO LEAD

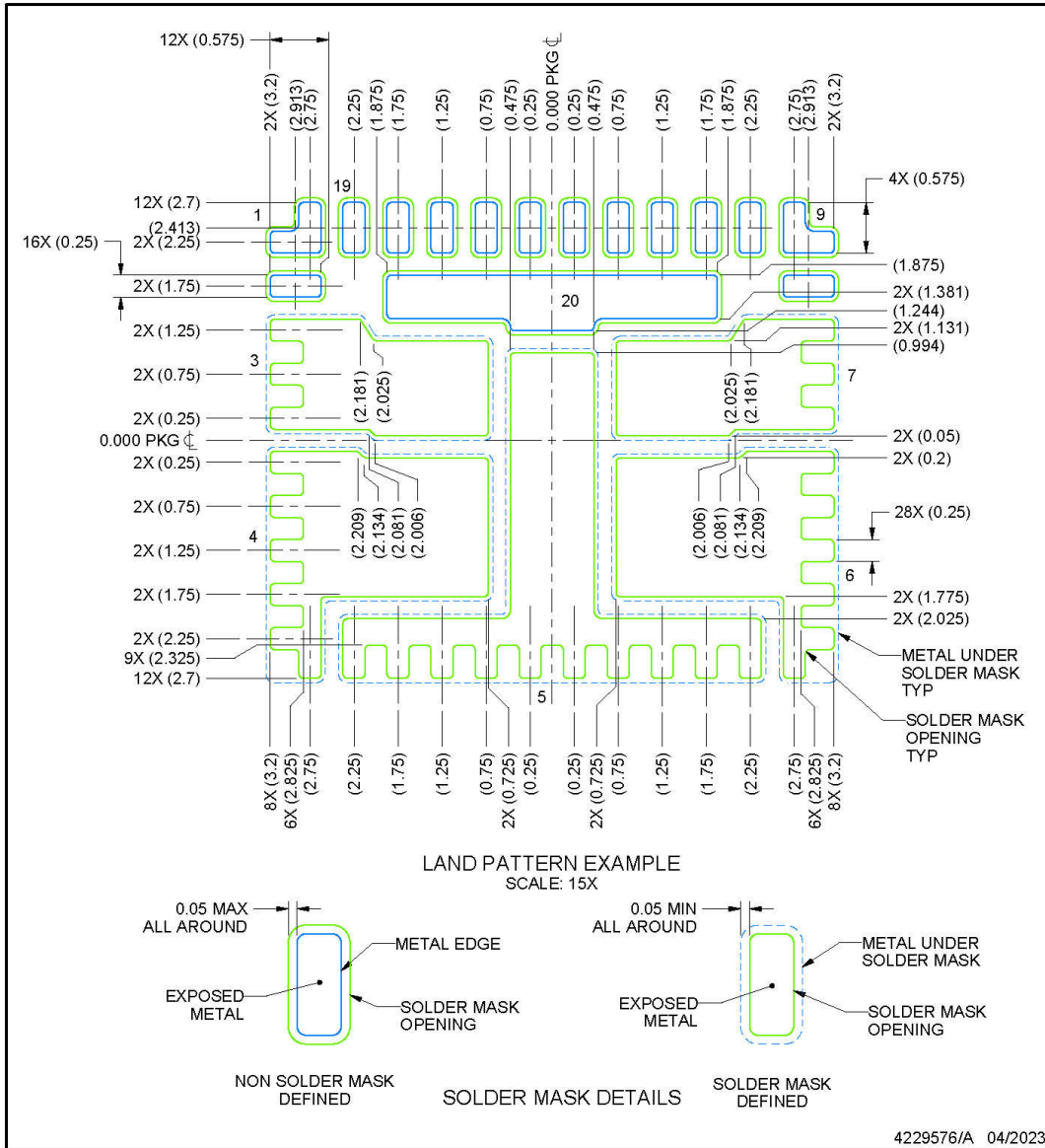

NOTES: (continued)

- This package is designed to be soldered to a thermal pad on the board. For more information, see Texas Instruments literature number SLUA271 ([www.ti.com/lit/sluea271](http://www.ti.com/lit/sluea271)).
- Vias are optional depending on application, refer to device data sheet. If any vias are implemented, refer to their locations shown on this view. It is recommended that vias under paste be filled, plugged or tented.

**EXAMPLE STENCIL DESIGN**

**VAA0020A**

**WQFN-FCRLF - 0.7 mm max height**

PLASTIC QUAD FLATPACK - NO LEAD

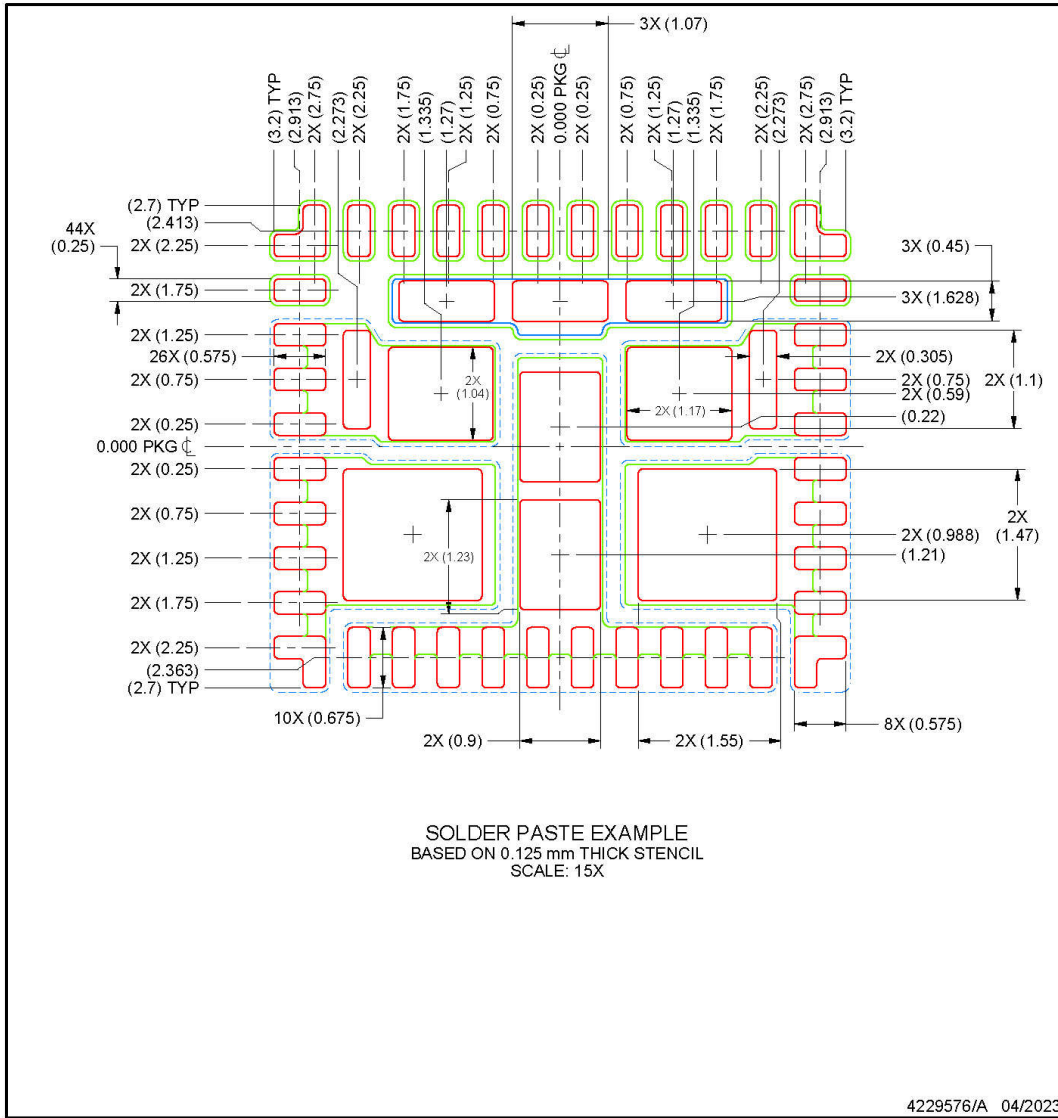

NOTES: (continued)

- 6. Laser cutting apertures with trapezoidal walls and rounded corners may offer better paste release. IPC-7525 may have alternate design recommendations.

**ADVANCE INFORMATION**

**PACKAGING INFORMATION**

Orderable part number	Status (1)	Material type (2)	Package   Pins	Package qty   Carrier	RoHS (3)	Lead finish/ Ball material (4)	MSL rating/ Peak reflow (5)	Op temp (°C)	Part marking (6)
TPS6287C50TEWVAAR	Active	Production	WQFN-FCRLF (VAA)   20	3000   LARGE T&R	Yes	NIPDAU	Level-2-260C-1 YEAR	150 to -40	T8C50TE

<sup>(1)</sup> **Status:** For more details on status, see our [product life cycle](#).

<sup>(2)</sup> **Material type:** When designated, preproduction parts are prototypes/experimental devices, and are not yet approved or released for full production. Testing and final process, including without limitation quality assurance, reliability performance testing, and/or process qualification, may not yet be complete, and this item is subject to further changes or possible discontinuation. If available for ordering, purchases will be subject to an additional waiver at checkout, and are intended for early internal evaluation purposes only. These items are sold without warranties of any kind.

<sup>(3)</sup> **RoHS values:** Yes, No, RoHS Exempt. See the [TI RoHS Statement](#) for additional information and value definition.

<sup>(4)</sup> **Lead finish/Ball material:** Parts may have multiple material finish options. Finish options are separated by a vertical ruled line. Lead finish/Ball material values may wrap to two lines if the finish value exceeds the maximum column width.

<sup>(5)</sup> **MSL rating/Peak reflow:** The moisture sensitivity level ratings and peak solder (reflow) temperatures. In the event that a part has multiple moisture sensitivity ratings, only the lowest level per JEDEC standards is shown. Refer to the shipping label for the actual reflow temperature that will be used to mount the part to the printed circuit board.

<sup>(6)</sup> **Part marking:** There may be an additional marking, which relates to the logo, the lot trace code information, or the environmental category of the part.

Multiple part markings will be inside parentheses. Only one part marking contained in parentheses and separated by a "~" will appear on a part. If a line is indented then it is a continuation of the previous line and the two combined represent the entire part marking for that device.

**Important Information and Disclaimer:** The information provided on this page represents TI's knowledge and belief as of the date that it is provided. TI bases its knowledge and belief on information provided by third parties, and makes no representation or warranty as to the accuracy of such information. Efforts are underway to better integrate information from third parties. TI has taken and continues to take reasonable steps to provide representative and accurate information but may not have conducted destructive testing or chemical analysis on incoming materials and chemicals. TI and TI suppliers consider certain information to be proprietary, and thus CAS numbers and other limited information may not be available for release.

In no event shall TI's liability arising out of such information exceed the total purchase price of the TI part(s) at issue in this document sold by TI to Customer on an annual basis.



# EXAMPLE BOARD LAYOUT

VAA0020A

WQFN-FCRLF - 0.7 mm max height

PLASTIC QUAD FLATPACK - NO LEAD

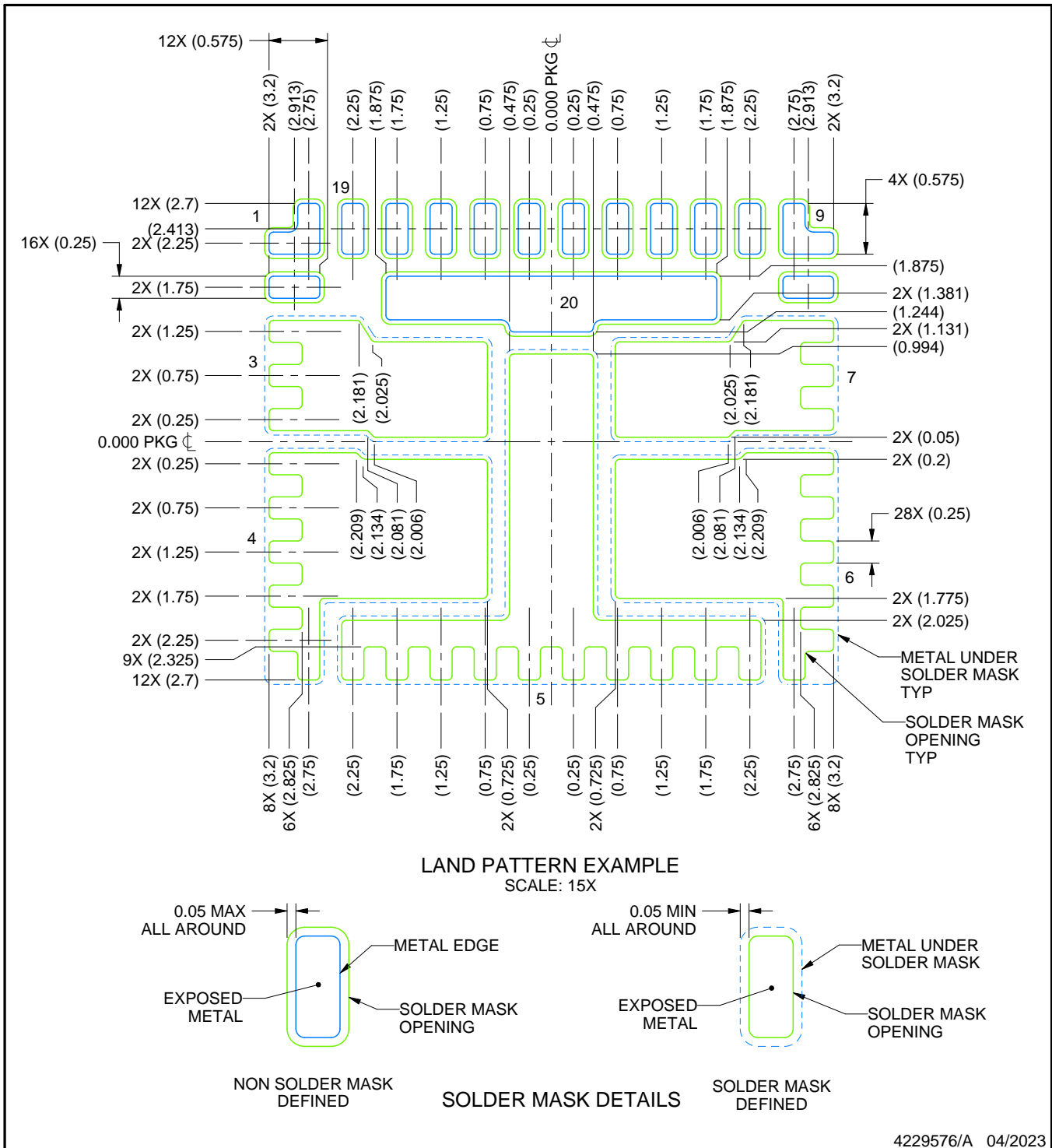

4229576/A 04/2023

NOTES: (continued)

4. This package is designed to be soldered to a thermal pad on the board. For more information, see Texas Instruments literature number SLUA271 ([www.ti.com/lit/slua271](http://www.ti.com/lit/slua271)).
5. Vias are optional depending on application, refer to device data sheet. If any vias are implemented, refer to their locations shown on this view. It is recommended that vias under paste be filled, plugged or tented.

# EXAMPLE STENCIL DESIGN

VAA0020A

WQFN-FCRLF - 0.7 mm max height

PLASTIC QUAD FLATPACK - NO LEAD

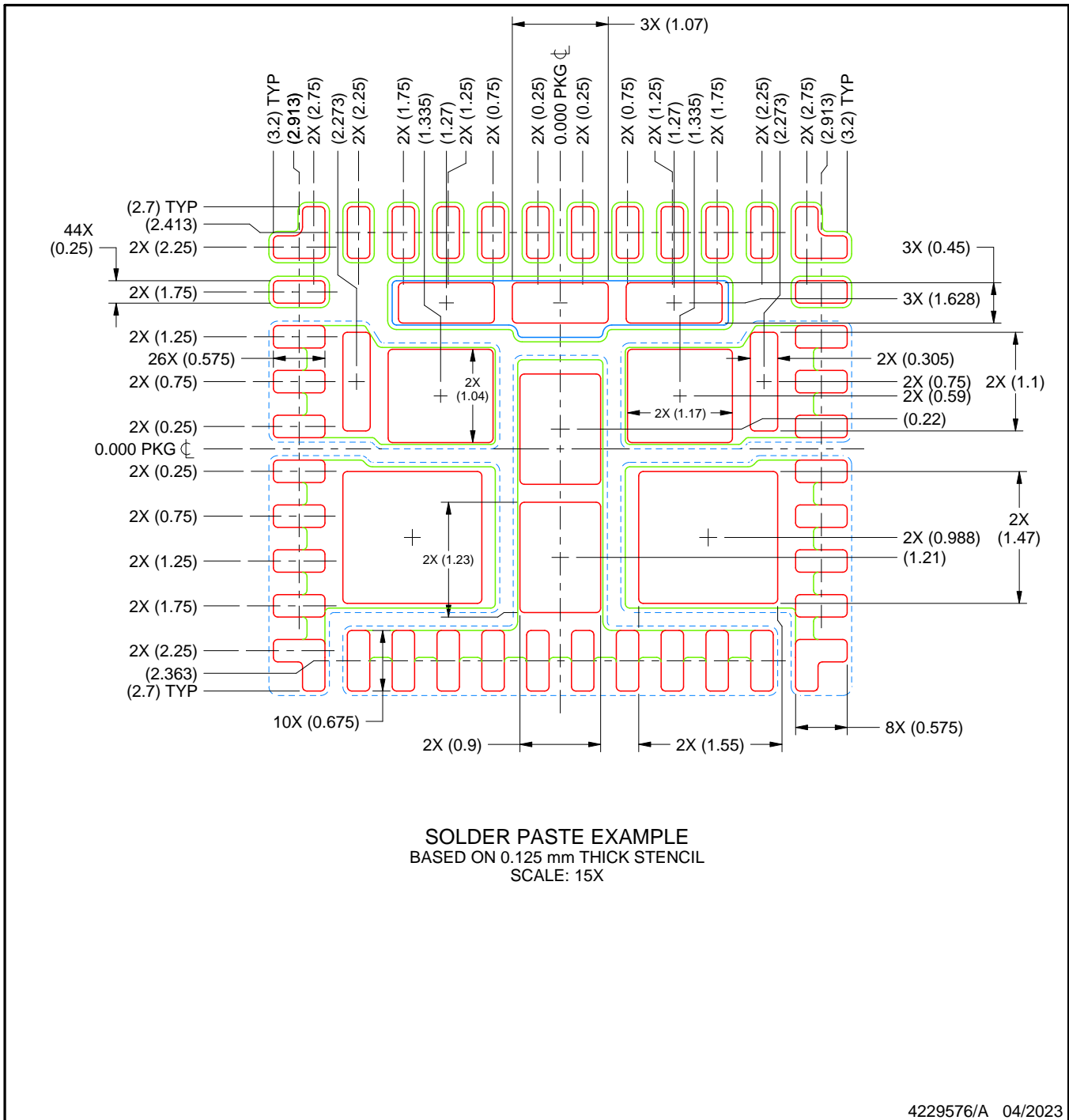

NOTES: (continued)

6. Laser cutting apertures with trapezoidal walls and rounded corners may offer better paste release. IPC-7525 may have alternate design recommendations.

## IMPORTANT NOTICE AND DISCLAIMER

TI PROVIDES TECHNICAL AND RELIABILITY DATA (INCLUDING DATASHEETS), DESIGN RESOURCES (INCLUDING REFERENCE DESIGNS), APPLICATION OR OTHER DESIGN ADVICE, WEB TOOLS, SAFETY INFORMATION, AND OTHER RESOURCES "AS IS" AND WITH ALL FAULTS, AND DISCLAIMS ALL WARRANTIES, EXPRESS AND IMPLIED, INCLUDING WITHOUT LIMITATION ANY IMPLIED WARRANTIES OF MERCHANTABILITY, FITNESS FOR A PARTICULAR PURPOSE OR NON-INFRINGEMENT OF THIRD PARTY INTELLECTUAL PROPERTY RIGHTS.

These resources are intended for skilled developers designing with TI products. You are solely responsible for (1) selecting the appropriate TI products for your application, (2) designing, validating and testing your application, and (3) ensuring your application meets applicable standards, and any other safety, security, regulatory or other requirements.

These resources are subject to change without notice. TI grants you permission to use these resources only for development of an application that uses the TI products described in the resource. Other reproduction and display of these resources is prohibited. No license is granted to any other TI intellectual property right or to any third party intellectual property right. TI disclaims responsibility for, and you fully indemnify TI and its representatives against any claims, damages, costs, losses, and liabilities arising out of your use of these resources.

TI's products are provided subject to [TI's Terms of Sale](#), [TI's General Quality Guidelines](#), or other applicable terms available either on [ti.com](http://ti.com) or provided in conjunction with such TI products. TI's provision of these resources does not expand or otherwise alter TI's applicable warranties or warranty disclaimers for TI products. Unless TI explicitly designates a product as custom or customer-specified, TI products are standard, catalog, general purpose devices.

TI objects to and rejects any additional or different terms you may propose.

Copyright © 2026, Texas Instruments Incorporated

Last updated 10/2025