

TPS62A20x-Q1 and TPS62A2Nx-Q1: 2.75V to 6V Input, 1A, 2A, 3A, 4A Automotive, Fast Transient, Synchronous Step-Down Converters

1 Features

- AEC-Q100 qualified for automotive applications
 - Temperature grade 1: -40°C to $+125^{\circ}\text{C}$ T_A
- **Functional Safety-Capable**
 - [Documentation available to aid functional safety system design](#)
- Family of 1A, 2A, 3A, and 4A devices
- Input voltage range: 2.75V to 6V
- Output voltage from 0.4V to 3.6V
- Switching frequency from 1.5MHz to 4MHz
 - External synchronization through the MODE/ SYNC pin
- Fast transient response with COT control
 - Fixed switching frequency during steady-state operation
 - 16 internal compensation settings to reduce output capacitance
- Low $R_{DS(on)}$ MOSFETS: 23m Ω and 15m Ω
- Minimum on-time of 30ns (maximum) at $V_{IN} = 5\text{V}$
- Selectable forced PWM mode through the MODE/ SYNC pin
- Programmable spread spectrum clocking
- Adjustable soft-start, soft-stop timings
- Power-good output with window comparator
- Active output discharge
- 2.1mm \times 2.1mm WQFN package with wettable flanks

2 Applications

- [ADAS domain controller](#)
- [Digital cockpit processing unit](#)
- [Driver monitoring](#)
- [Front camera](#)

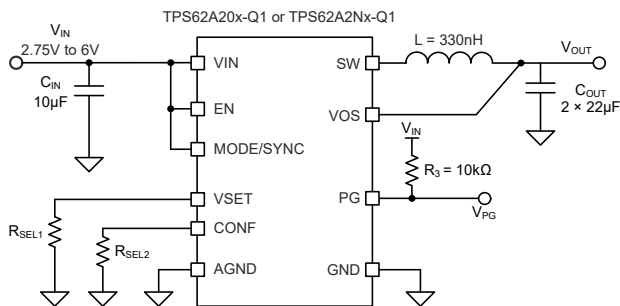

Simplified Schematic for TPS62A20x-Q1 and TPS62A2Nx-Q1

3 Description

The TPS62A20x-Q1 or TPS62A2Nx-Q1 series are families of pin-to-pin compatible, high-efficiency, synchronous step-down DC-DC converters capable of delivering continuous output currents of 1A, 2A, 3A, and 4A. Using a constant on-time (COT) control topology, these devices provide fast transient response while maintaining fixed switching frequency operation during steady-state conditions.

To enhance loop performance, the devices offer 16 selectable internal compensation settings, enabling higher bandwidth and reducing output capacitance. Integrated low $R_{DS(on)}$ MOSFETs support continuous output up to 4A even at high ambient temperatures.

The switching frequency is adjustable from 1.5MHz to 4MHz and supports synchronization to an external clock. In PFM/PWM mode, the device automatically enters power-save mode at light loads to achieve high efficiency across the full load range. The device maintains the output voltage accuracy within $\pm 0.8\%$ in PWM mode for $V_{OUT} \geq 0.5\text{V}$. The soft-start feature provides controlled power-up and limits inrush current.

Device Information

PART NUMBER	OUTPUT CURRENT	PACKAGE ⁽¹⁾	PACKAGE SIZE ⁽²⁾
TPS62A201-Q1 ⁽³⁾	1A	RZX (UQFN-FCRLF, 13)	2.1mm \times 2.1mm
TPS62A202-Q1 ⁽³⁾	2A		
TPS62A203-Q1 ⁽³⁾	3A		
TPS62A204-Q1 ⁽³⁾	4A		
TPS62A2N1-Q1 ⁽³⁾	1A		
TPS62A2N2-Q1 ⁽³⁾	2A		
TPS62A2N3-Q1 ⁽³⁾	3A		
TPS62A2N4-Q1	4A		

- (1) For more information, see [Section 6](#).
- (2) The package size (length \times width) is a nominal value and includes pins, where applicable.
- (3) Preview information (not Production Data).



4 Device and Documentation Support

4.1 Device Support

4.1.1 Third-Party Products Disclaimer

TI'S PUBLICATION OF INFORMATION REGARDING THIRD-PARTY PRODUCTS OR SERVICES DOES NOT CONSTITUTE AN ENDORSEMENT REGARDING THE SUITABILITY OF SUCH PRODUCTS OR SERVICES OR A WARRANTY, REPRESENTATION OR ENDORSEMENT OF SUCH PRODUCTS OR SERVICES, EITHER ALONE OR IN COMBINATION WITH ANY TI PRODUCT OR SERVICE.

4.2 Documentation Support

4.2.1 Related Documentation

For related documentation, see the following:

Texas Instruments, [TPS62A204-Q1 Step-Down Converter Evaluation Module EVM user's guide](#)

4.3 Receiving Notification of Documentation Updates

To receive notification of documentation updates, navigate to the device product folder on [ti.com](#). Click on *Notifications* to register and receive a weekly digest of any product information that has changed. For change details, review the revision history included in any revised document.

4.4 Support Resources

[TI E2E™ support forums](#) are an engineer's go-to source for fast, verified answers and design help — straight from the experts. Search existing answers or ask your own question to get the quick design help you need.

Linked content is provided "AS IS" by the respective contributors. They do not constitute TI specifications and do not necessarily reflect TI's views; see TI's [Terms of Use](#).

4.5 Trademarks

TI E2E™ is a trademark of Texas Instruments.

All trademarks are the property of their respective owners.

4.6 Electrostatic Discharge Caution



This integrated circuit can be damaged by ESD. Texas Instruments recommends that all integrated circuits be handled with appropriate precautions. Failure to observe proper handling and installation procedures can cause damage.

ESD damage can range from subtle performance degradation to complete device failure. Precision integrated circuits may be more susceptible to damage because very small parametric changes could cause the device not to meet its published specifications.

4.7 Glossary

[TI Glossary](#) This glossary lists and explains terms, acronyms, and definitions.

5 Revision History

NOTE: Page numbers for previous revisions may differ from page numbers in the current version.

Changes from Revision * (November 2025) to Revision A (June 2026)	Page
• Changed the document status from Advance Information to Production Mix.....	1
• Updated the features list to the production specifications.....	1
• Updated the Description to the production specifications.....	1

6 Mechanical, Packaging, and Orderable Information

The following pages include mechanical, packaging, and orderable information. This information is the most current data available for the designated devices. This data is subject to change without notice and revision of this document. For browser-based versions of this data sheet, refer to the left-hand navigation.

PACKAGING INFORMATION

Orderable part number	Status (1)	Material type (2)	Package Pins	Package qty Carrier	RoHS (3)	Lead finish/ Ball material (4)	MSL rating/ Peak reflow (5)	Op temp (°C)	Part marking (6)
TPS62A2N4DQWRZXRQ1	Active	Production	UQFN-FCRLF (RZX) 13	3000 LARGE T&R	Yes	NIPDAU	Level-2-260C-1 YEAR	-40 to 125	TN4D
XPS62A2N4DQWRZXRQ1	Active	Preproduction	UQFN-FCRLF (RZX) 13	3000 LARGE T&R	-	Call TI	Call TI	-40 to 125	

(1) **Status:** For more details on status, see our [product life cycle](#).

(2) **Material type:** When designated, preproduction parts are prototypes/experimental devices, and are not yet approved or released for full production. Testing and final process, including without limitation quality assurance, reliability performance testing, and/or process qualification, may not yet be complete, and this item is subject to further changes or possible discontinuation. If available for ordering, purchases will be subject to an additional waiver at checkout, and are intended for early internal evaluation purposes only. These items are sold without warranties of any kind.

(3) **RoHS values:** Yes, No, RoHS Exempt. See the [TI RoHS Statement](#) for additional information and value definition.

(4) **Lead finish/Ball material:** Parts may have multiple material finish options. Finish options are separated by a vertical ruled line. Lead finish/Ball material values may wrap to two lines if the finish value exceeds the maximum column width.

(5) **MSL rating/Peak reflow:** The moisture sensitivity level ratings and peak solder (reflow) temperatures. In the event that a part has multiple moisture sensitivity ratings, only the lowest level per JEDEC standards is shown. Refer to the shipping label for the actual reflow temperature that will be used to mount the part to the printed circuit board.

(6) **Part marking:** There may be an additional marking, which relates to the logo, the lot trace code information, or the environmental category of the part.

Multiple part markings will be inside parentheses. Only one part marking contained in parentheses and separated by a "~" will appear on a part. If a line is indented then it is a continuation of the previous line and the two combined represent the entire part marking for that device.

Important Information and Disclaimer: The information provided on this page represents TI's knowledge and belief as of the date that it is provided. TI bases its knowledge and belief on information provided by third parties, and makes no representation or warranty as to the accuracy of such information. Efforts are underway to better integrate information from third parties. TI has taken and continues to take reasonable steps to provide representative and accurate information but may not have conducted destructive testing or chemical analysis on incoming materials and chemicals. TI and TI suppliers consider certain information to be proprietary, and thus CAS numbers and other limited information may not be available for release.

In no event shall TI's liability arising out of such information exceed the total purchase price of the TI part(s) at issue in this document sold by TI to Customer on an annual basis.

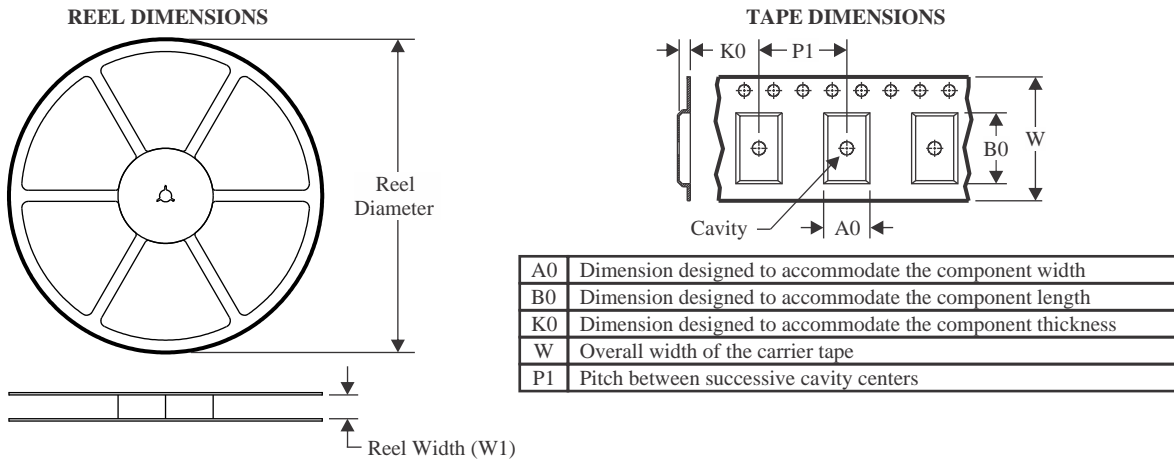
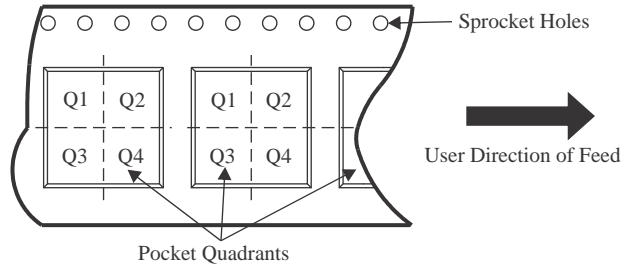
TAPE AND REEL INFORMATION

QUADRANT ASSIGNMENTS FOR PIN 1 ORIENTATION IN TAPE

*All dimensions are nominal

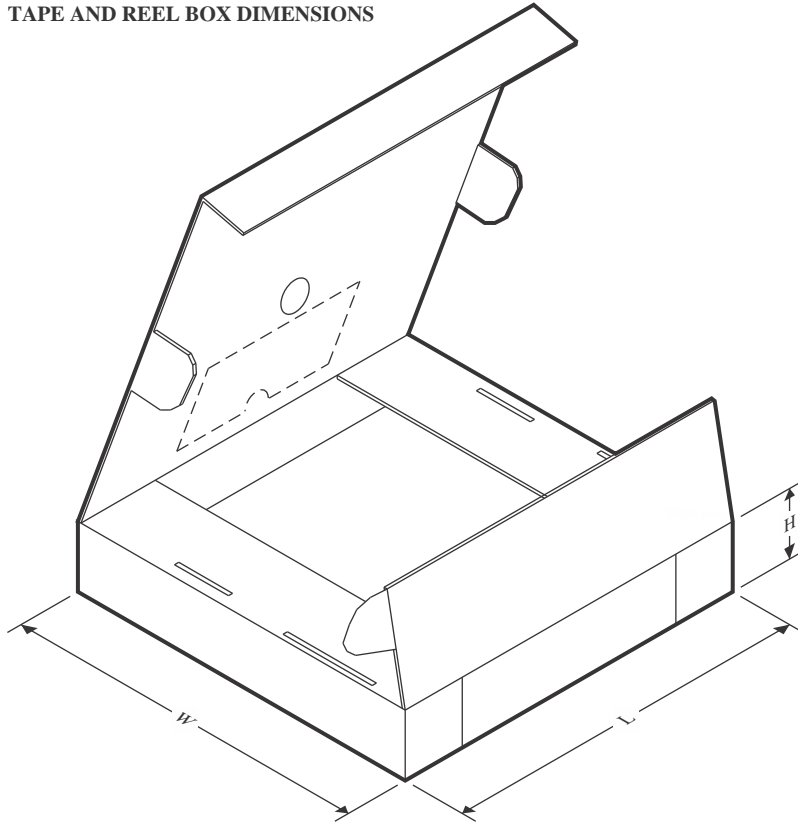
Device	Package Type	Package Drawing	Pins	SPQ	Reel Diameter (mm)	Reel Width W1 (mm)	A0 (mm)	B0 (mm)	K0 (mm)	P1 (mm)	W (mm)	Pin1 Quadrant
TPS62A2N4DQWRZRQ1	UQFN-FCRLF	RZX	13	3000	180.0	8.4	2.3	2.3	0.9	4.0	8.0	Q2

TAPE AND REEL BOX DIMENSIONS

*All dimensions are nominal

Device	Package Type	Package Drawing	Pins	SPQ	Length (mm)	Width (mm)	Height (mm)
TPS62A2N4DQWRZRQ1	UQFN-FCRLF	RZX	13	3000	210.0	185.0	35.0

RZX0013A



PACKAGE OUTLINE

UQFN-FCRLF - 0.65 mm max height

PLASTIC QUAD FLATPACK - NO LEAD

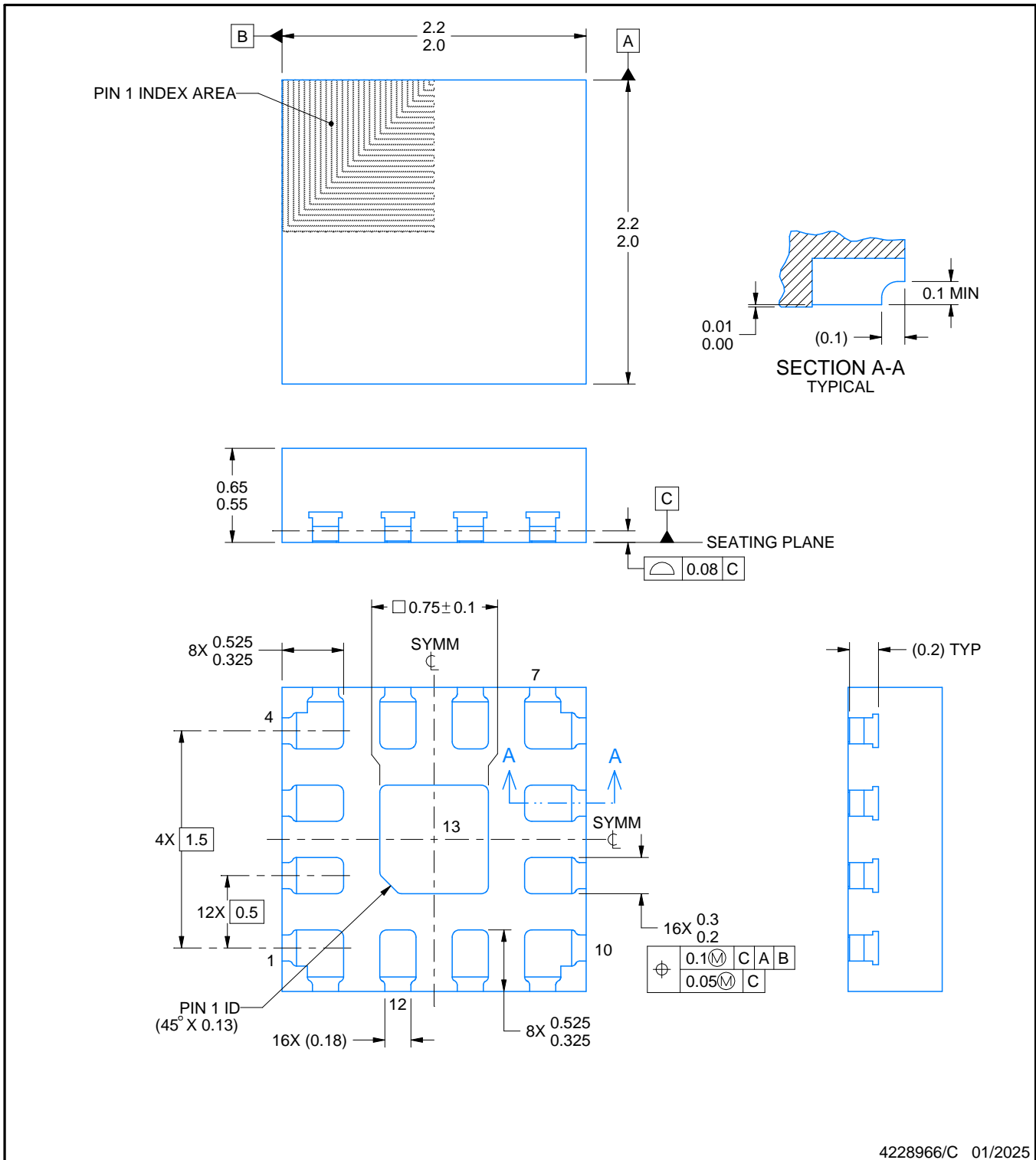

NOTES:

1. All linear dimensions are in millimeters. Any dimensions in parenthesis are for reference only. Dimensioning and tolerancing per ASME Y14.5M.
2. This drawing is subject to change without notice.
3. The package thermal pad must be soldered to the printed circuit board for thermal and mechanical performance.

EXAMPLE BOARD LAYOUT

RZX0013A

UQFN-FCRLF - 0.65 mm max height

PLASTIC QUAD FLATPACK - NO LEAD

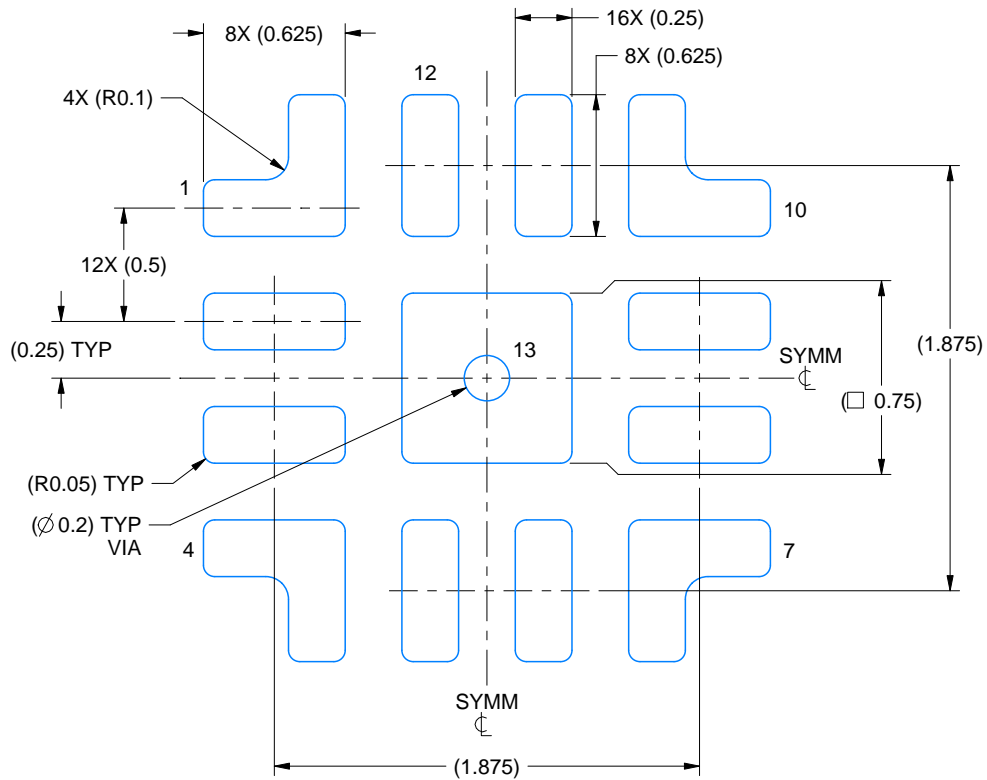

LAND PATTERN EXAMPLE
EXPOSED METAL SHOWN
SCALE: 30X

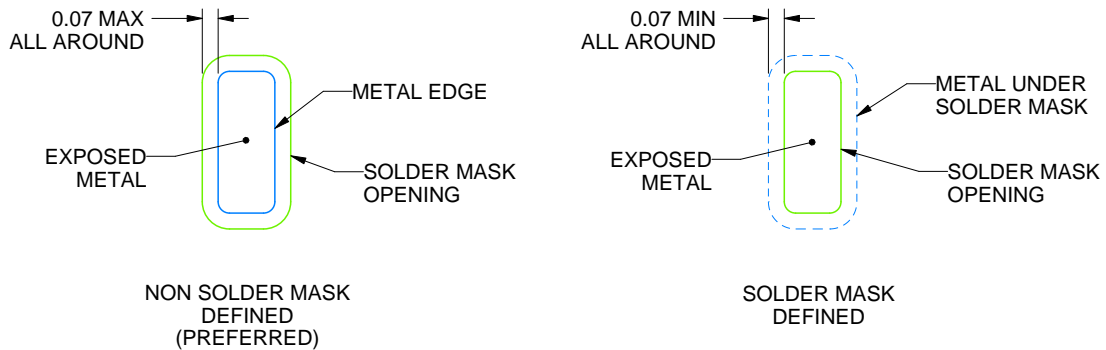

SOLDER MASK DETAILS

4228966/C 01/2025

NOTES: (continued)

4. This package is designed to be soldered to a thermal pad on the board. For more information, see Texas Instruments literature number SLUA271 (www.ti.com/lit/slua271).
5. Vias are optional depending on application, refer to device data sheet. If some or all are implemented, recommended via locations are shown.

EXAMPLE STENCIL DESIGN

RZX0013A

UQFN-FCRLF - 0.65 mm max height

PLASTIC QUAD FLATPACK - NO LEAD

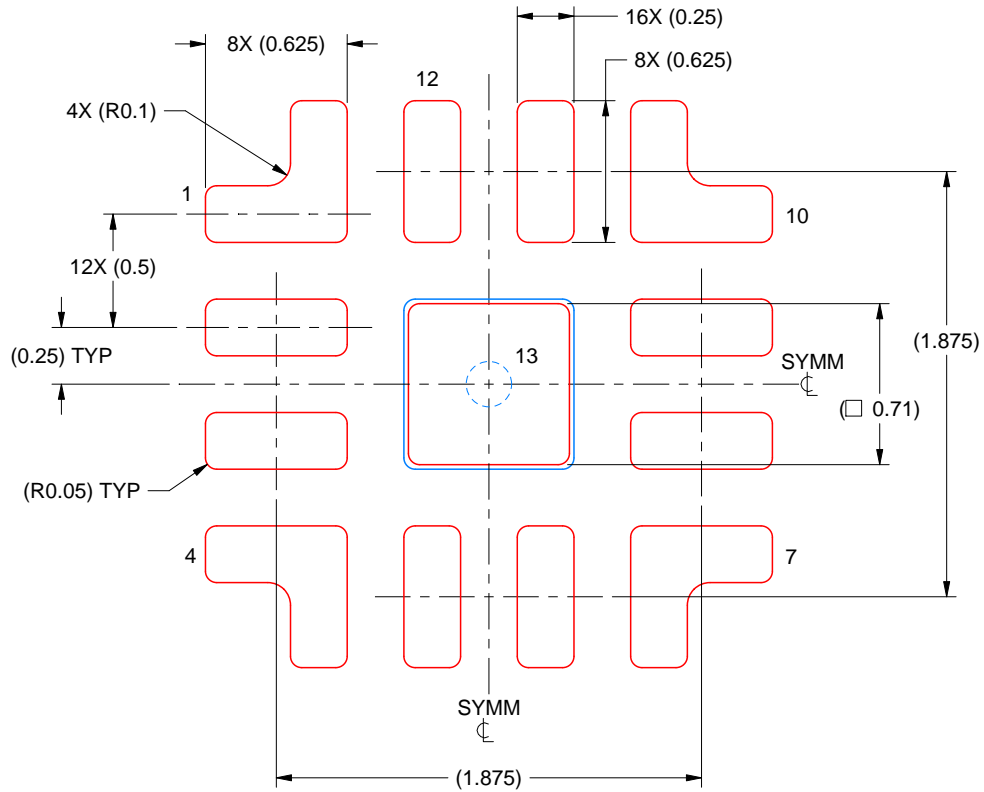

SOLDER PASTE EXAMPLE
BASED ON 0.125 mm THICK STENCIL
SCALE: 30X

SOLDER PASTE COVERAGE BY AREA UNDER PACKAGE
PAD 13: 90%

4228966/C 01/2025

NOTES: (continued)

6. Laser cutting apertures with trapezoidal walls and rounded corners may offer better paste release. IPC-7525 may have alternate design recommendations.

IMPORTANT NOTICE AND DISCLAIMER

TI PROVIDES TECHNICAL AND RELIABILITY DATA (INCLUDING DATASHEETS), DESIGN RESOURCES (INCLUDING REFERENCE DESIGNS), APPLICATION OR OTHER DESIGN ADVICE, WEB TOOLS, SAFETY INFORMATION, AND OTHER RESOURCES "AS IS" AND WITH ALL FAULTS, AND DISCLAIMS ALL WARRANTIES, EXPRESS AND IMPLIED, INCLUDING WITHOUT LIMITATION ANY IMPLIED WARRANTIES OF MERCHANTABILITY, FITNESS FOR A PARTICULAR PURPOSE OR NON-INFRINGEMENT OF THIRD PARTY INTELLECTUAL PROPERTY RIGHTS.

These resources are intended for skilled developers designing with TI products. You are solely responsible for (1) selecting the appropriate TI products for your application, (2) designing, validating and testing your application, and (3) ensuring your application meets applicable standards, and any other safety, security, regulatory or other requirements.

These resources are subject to change without notice. TI grants you permission to use these resources only for development of an application that uses the TI products described in the resource. Other reproduction and display of these resources is prohibited. No license is granted to any other TI intellectual property right or to any third party intellectual property right. TI disclaims responsibility for, and you fully indemnify TI and its representatives against any claims, damages, costs, losses, and liabilities arising out of your use of these resources.

TI's products are provided subject to [TI's Terms of Sale](#), [TI's General Quality Guidelines](#), or other applicable terms available either on [ti.com](#) or provided in conjunction with such TI products. TI's provision of these resources does not expand or otherwise alter TI's applicable warranties or warranty disclaimers for TI products. Unless TI explicitly designates a product as custom or customer-specified, TI products are standard, catalog, general purpose devices.

TI objects to and rejects any additional or different terms you may propose.

Copyright © 2026, Texas Instruments Incorporated

Last updated 10/2025