TRF4140-Q1 Abstract

Low-Frequency Transceiver for Immobilizer, Passive Start, Passive Entry

1 Device Overview

1.1 Features

- Benefits
 - Full Embedded Sequence Timing Controller Removes All Timing Constraints From the Host Controller
 - Automatic Sequence Repetition for Easy Implementation of Energy-Efficient Polling Systems
 - Separate Transmit and Receive Buffers Reduce Host Controller Performance Requirements
 - Embedded Sequence-Auto-Repeat Enables Low-Power Polling System Without Host Controller Interaction
 - Embedded Half-Duplex (HDX) Protocol Support Enables Flexible and Scalable System Implementation
 - Sine-Wave Controlled Transmitter Stages Enable High-Power Remote Antenna Systems With Cable Lengths of Several Meters and Superior EMC Performance
 - Sequence Preloading With Event-Triggered Execution for Fastest System Reaction Time
- Features
 - Integrated Boost Controller for Wide Supply Voltage Range With Jump Start and Load Dump Protection
 - Antenna Driver With up to 20-V Peak-to-Peak Output Voltage Amplitude and up to 1-A Peak Antenna Current With Sine-Wave or Square-Wave Output
 - Flexible Host Control Interface
 - 4-Wire SPI
 - Configurable I/O Functions to Extend Controller Interface Such as an Interrupt Request Signal
 - Interface Voltage Supply Range From 2.5 V to 5.5 V
 - Ultra-Low Current Consumption in Sleep State
 - Fractional Synthesizer With 10-kHz to 500-kHz Frequency Range With 60-Hz Step Size
 - PSK and ASK Transmitter Stage
 - FSK Receiver and Demodulator
 - Four Programmable Half-Bridge MOSFET Antenna Drivers
 - Pairs of Half-Bridge Antenna Drivers can be Used Together as a Full-Bridge Driver to Double the Possible Output Voltage Amplitude
 - Antenna Current Measurement With 5-Bit Resolution for High Side and Low Side of Antenna Driver Stages
 - Programmable Antenna Driver Output Voltage in Sine-Wave Mode
 - Supply-Controlled Antenna Driver Voltage in Square-Wave Mode
 - Output Stage is Overload Protected for Over-Current and Over-Temperature Conditions
 - Antenna Driver Diagnostics: Short to Ground, Short to Antenna Driver Supply Voltage, and Open-Load Detection
 - Supports On-Off Keying With Data Rates up to 70 kbps for Downlink and Uplink

1.2 Applications

- Car Access
- Immobilizers
- Passive Entry, Passive Start (PEPS)
- RFID Tag Readers (Half Duplex)
- Other Applications Where the Physical Characteristics of Low-Frequency Radio are Beneficial



1.3 Description

NOTE

This document is an abbreviated version of the full TRF4140-Q1 data sheet. For access to the full data sheet, silicon errata, application report, and other support collateral, [complete the request form](#).

The TRF4140-Q1 low-frequency (LF) transceiver base station device is intended for immobilizer and PEPS systems to communicate with LF transponders, remote keyless entry, and passive entry devices. The antenna driver stage consists of four MOSFET antenna drivers to send modulated LF transmissions and a receiver for detection and demodulation of LF transponder responses. The HDX communication scheme uses frequency shift keying (FSK) as the uplink modulation. The device can drive LF antennas to provide a wake-up and data sequence (PEPS), and it can also receive transponder responses on any or all channels (immobilizer).

The TRF4140-Q1 device needs V_{DD} supply (5 V) for its control blocks and to feed the integrated logic voltage regulator. The antenna driver is supplied separately by V_{DDH} (4 V to 20 V). This voltage can be used to generate a sine-wave output signal for superior EMC performance, which is important for remote antenna applications with several meters of antenna cable.

The TRF4140-Q1 device manages all timings required for a communication sequence without the need for an accurate host controller interaction. In conjunction with transmit and receive FIFOs, the host controller is off-loaded from all timing-critical events, which enables easy host controller process scheduling. In particular, the host controller start-up process for an automotive body control module is tremendously relaxed by this base station device.

The TRF4140-Q1 device supports sequence preloading and sequence execution on external events to start the immobilization process exactly when the key fob is detected. So, delays due to configuration can be avoided in inconvenient time frames.

Device Information⁽¹⁾

PART NUMBER	PACKAGE	BODY SIZE
TRF4140QPHNRQ1	HTQFP (48)	7 mm x 7 mm

(1) For more information, see [Section 4, Mechanical, Packaging, and Orderable Information](#).

1.4 Functional Block Diagram

Figure 1-1 shows the functional block diagram and a typical application of TRF4140-Q1 and its function blocks.

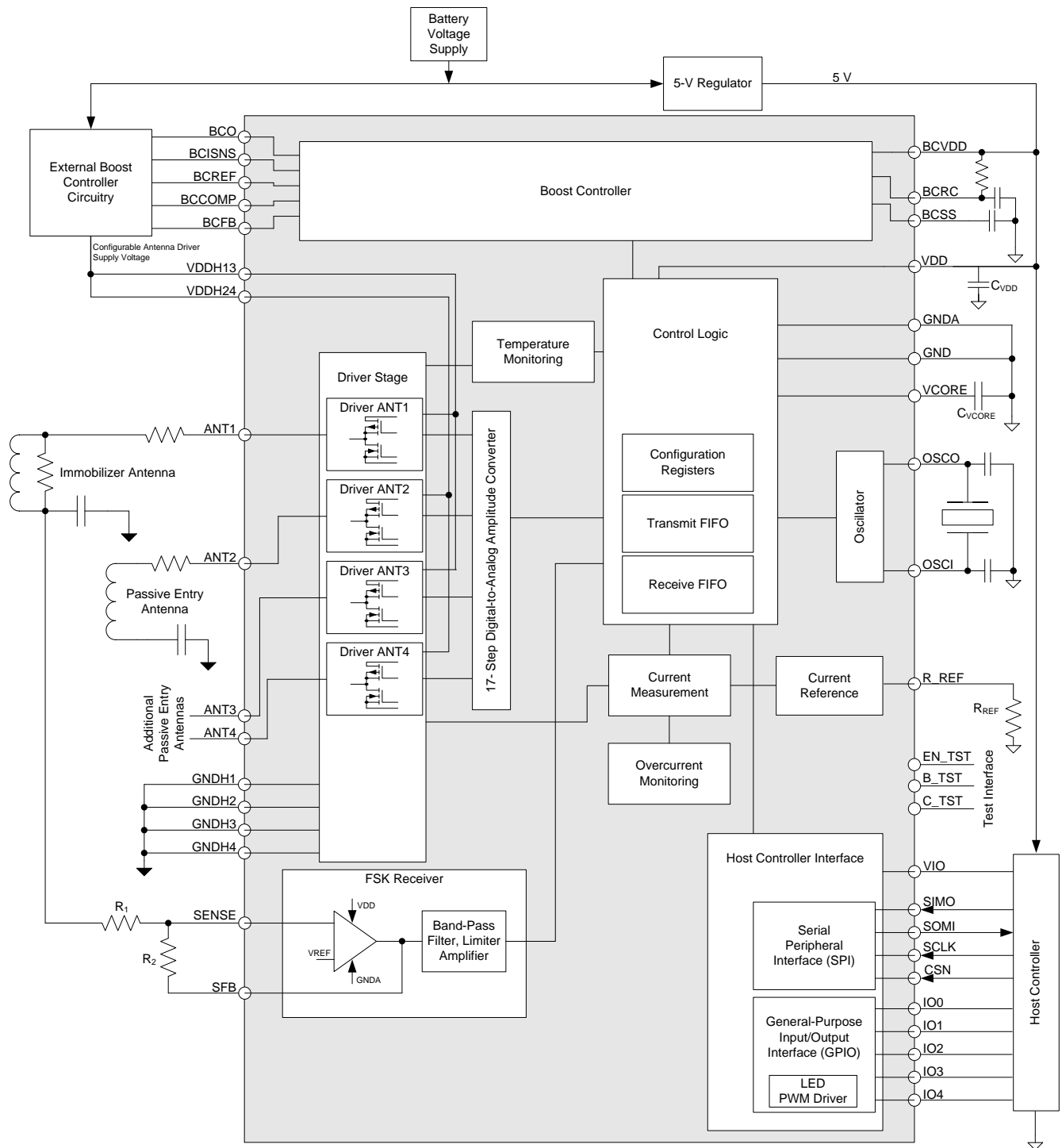

BAST_FBD_4ANT

Copyright © 2016, Texas Instruments Incorporated

Figure 1-1. TRF4140-Q1 Block Diagram and Application Example

Table of Contents

1 Device Overview	1	3.2 Device Nomenclature.....	5
1.1 Features	1	3.3 Documentation Support	5
1.2 Applications.....	1	3.4 Community Resources	6
1.3 Description	2	3.5 Trademarks	6
1.4 Functional Block Diagram	3	3.6 Electrostatic Discharge Caution	6
2 Revision History	4	3.7 Export Control Notice.....	6
3 Device and Documentation Support	5	3.8 Glossary	6
3.1 Getting Started and Next Steps	5	4 Mechanical, Packaging, and Orderable Information	6

2 Revision History

Changes from April 1, 2018 to October 31, 2018

Page

- Changed [Section 4, Mechanical, Packaging, and Orderable Information](#)..... **[6](#)**

3 Device and Documentation Support

3.1 Getting Started and Next Steps

For more information on the TI NFC/RFID devices and the tools and software that are available to help with your development, visit [Overview for NFC / RFID](#).

3.2 Device Nomenclature

Figure 3-1 provides a legend for reading the complete device name for any family member.

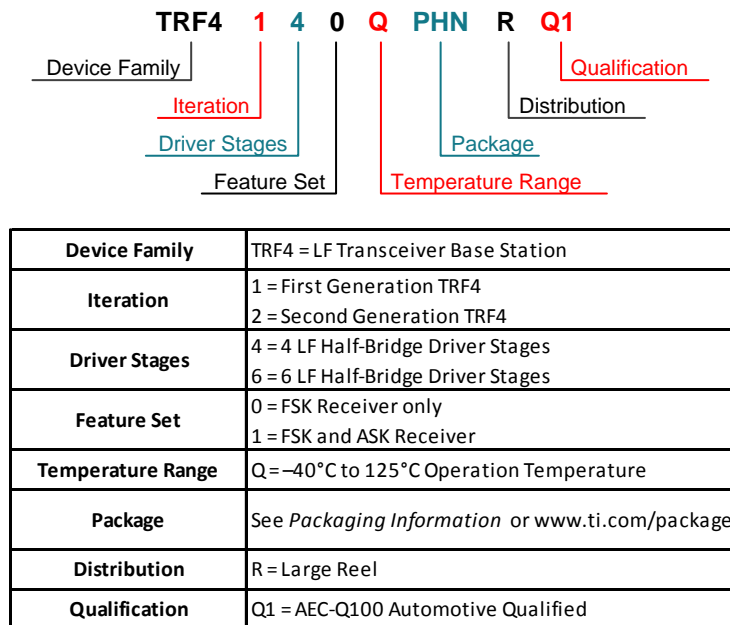

Figure 3-1. Device Nomenclature

3.3 Documentation Support

The following documents describe the TRF4140-Q1 device. Copies of these documents are available on the Internet at www.ti.com.

Receiving Notice of Document Updates

To receive notification of documentation updates—including silicon errata—go to the product folder for your device on ti.com (for example, [TRF4140-Q1](#)). In the upper right corner, click the "Alert me" button. This registers you to receive a weekly digest of product information that has changed (if any). For change details, check the revision history of any revised document.

Errata

[TRF4140-Q1 Errata Sheet](#) Describes known design exceptions and related workarounds of this device.

Application Reports

[Using a TRF4xxx Device as an LF Transceiver Base Station](#) Provides a variety of application advice for designing an LF base station with TRF4140-Q1 devices.

[Using a TRF4xxx Device as an LF Transceiver Base Station](#) Provides a variety of application advice for designing an LF base station with TRF4140-Q1 devices.

3.4 Community Resources

The following link connects to TI community resources. Linked contents are provided "AS IS" by the respective contributors. They do not constitute TI specifications and do not necessarily reflect TI's views; see TI's [Terms of Use](#).

TI E2E™ Community

TI's Engineer-to-Engineer (E2E) Community. Created to foster collaboration among engineers. At e2e.ti.com, you can ask questions, share knowledge, explore ideas and help solve problems with fellow engineers.

3.5 Trademarks

E2E is a trademark of Texas Instruments.

3.6 Electrostatic Discharge Caution



This integrated circuit can be damaged by ESD. Texas Instruments recommends that all integrated circuits be handled with appropriate precautions. Failure to observe proper handling and installation procedures can cause damage.

ESD damage can range from subtle performance degradation to complete device failure. Precision integrated circuits may be more susceptible to damage because very small parametric changes could cause the device not to meet its published specifications.

3.7 Export Control Notice

Recipient agrees to not knowingly export or re-export, directly or indirectly, any product or technical data (as defined by the U.S., EU, and other Export Administration Regulations) including software, or any controlled product restricted by other applicable national regulations, received from disclosing party under nondisclosure obligations (if any), or any direct product of such technology, to any destination to which such export or re-export is restricted or prohibited by U.S. or other applicable laws, without obtaining prior authorization from U.S. Department of Commerce and other competent Government authorities to the extent required by those laws.

3.8 Glossary

[TI Glossary](#) This glossary lists and explains terms, acronyms, and definitions.

4 Mechanical, Packaging, and Orderable Information

The following pages include mechanical, packaging, and orderable information. This information is the most current data available for the designated devices. This data is subject to change without notice and revision of this document. For browser-based versions of this data sheet, refer to the left-hand navigation.

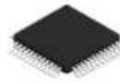

PACKAGE OUTLINE

PHN0048G

PowerPAD™ HTQFP - 1.2 mm max height

PLASTIC QUAD FLATPACK

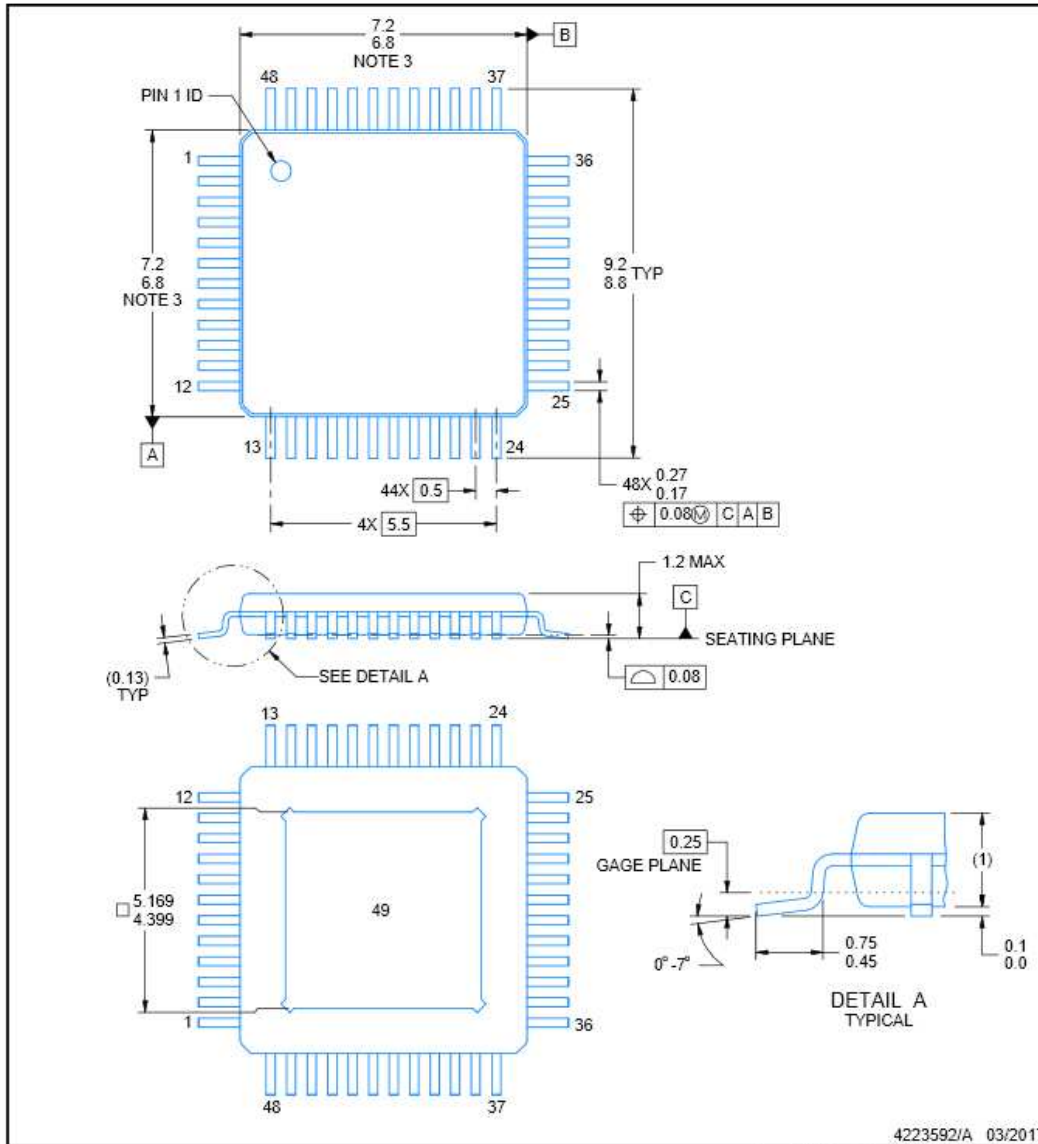

NOTES:

1. All linear dimensions are in millimeters. Any dimensions in parenthesis are for reference only. Dimensioning and tolerancing per ASME Y14.5M.
2. This drawing is subject to change without notice.
3. This dimension does not include mold flash, protrusions, or gate burrs. Mold flash, protrusions, or gate burrs shall not exceed 0.15 mm per side.
4. Reference JEDEC registration MS-026.

4223592/A 03/2017
PowerPAD is a trademark of Texas Instruments.

EXAMPLE STENCIL DESIGN

PHN0048G

PowerPAD™ HTQFP - 1.2 mm max height

PLASTIC QUAD FLATPACK

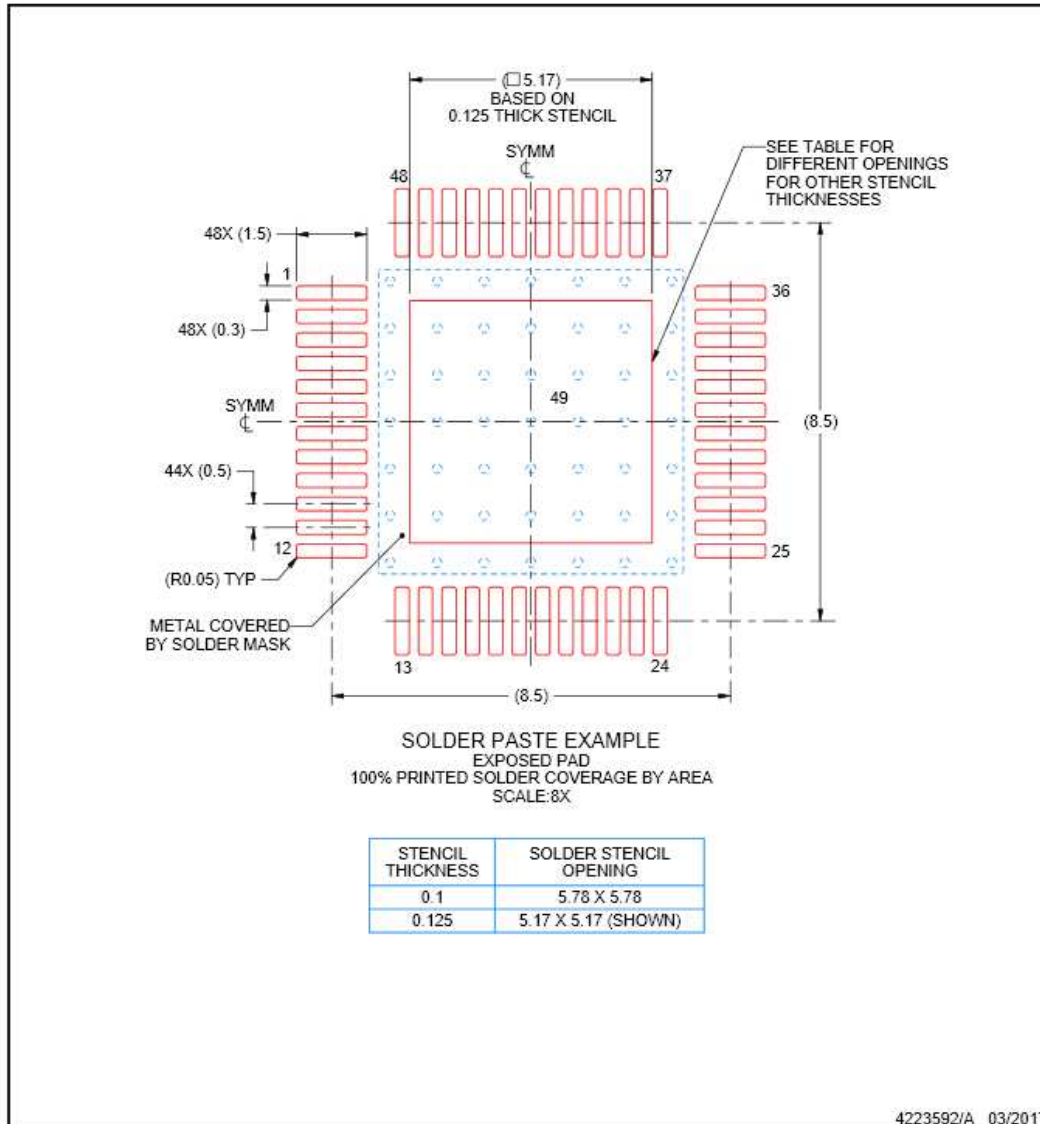

NOTES: (continued)

- 10. Laser cutting apertures with trapezoidal walls and rounded corners may offer better paste release. IPC-7525 may have alternate design recommendations.
- 11. Board assembly site may have different recommendations for stencil design.

PACKAGING INFORMATION

Orderable part number	Status (1)	Material type (2)	Package Pins	Package qty Carrier	RoHS (3)	Lead finish/ Ball material (4)	MSL rating/ Peak reflow (5)	Op temp (°C)	Part marking (6)
TRF4140QPHNRQ1	Active	Production	HTQFP (PHN) 48	2000 LARGE T&R	Yes	NIPDAU	Level-3-260C-168 HR	-40 to 125	TRF4140C

(1) **Status:** For more details on status, see our [product life cycle](#).

(2) **Material type:** When designated, preproduction parts are prototypes/experimental devices, and are not yet approved or released for full production. Testing and final process, including without limitation quality assurance, reliability performance testing, and/or process qualification, may not yet be complete, and this item is subject to further changes or possible discontinuation. If available for ordering, purchases will be subject to an additional waiver at checkout, and are intended for early internal evaluation purposes only. These items are sold without warranties of any kind.

(3) **RoHS values:** Yes, No, RoHS Exempt. See the [TI RoHS Statement](#) for additional information and value definition.

(4) **Lead finish/Ball material:** Parts may have multiple material finish options. Finish options are separated by a vertical ruled line. Lead finish/Ball material values may wrap to two lines if the finish value exceeds the maximum column width.

(5) **MSL rating/Peak reflow:** The moisture sensitivity level ratings and peak solder (reflow) temperatures. In the event that a part has multiple moisture sensitivity ratings, only the lowest level per JEDEC standards is shown. Refer to the shipping label for the actual reflow temperature that will be used to mount the part to the printed circuit board.

(6) **Part marking:** There may be an additional marking, which relates to the logo, the lot trace code information, or the environmental category of the part.

Multiple part markings will be inside parentheses. Only one part marking contained in parentheses and separated by a "-" will appear on a part. If a line is indented then it is a continuation of the previous line and the two combined represent the entire part marking for that device.

Important Information and Disclaimer: The information provided on this page represents TI's knowledge and belief as of the date that it is provided. TI bases its knowledge and belief on information provided by third parties, and makes no representation or warranty as to the accuracy of such information. Efforts are underway to better integrate information from third parties. TI has taken and continues to take reasonable steps to provide representative and accurate information but may not have conducted destructive testing or chemical analysis on incoming materials and chemicals. TI and TI suppliers consider certain information to be proprietary, and thus CAS numbers and other limited information may not be available for release.

In no event shall TI's liability arising out of such information exceed the total purchase price of the TI part(s) at issue in this document sold by TI to Customer on an annual basis.

IMPORTANT NOTICE AND DISCLAIMER

TI PROVIDES TECHNICAL AND RELIABILITY DATA (INCLUDING DATASHEETS), DESIGN RESOURCES (INCLUDING REFERENCE DESIGNS), APPLICATION OR OTHER DESIGN ADVICE, WEB TOOLS, SAFETY INFORMATION, AND OTHER RESOURCES "AS IS" AND WITH ALL FAULTS, AND DISCLAIMS ALL WARRANTIES, EXPRESS AND IMPLIED, INCLUDING WITHOUT LIMITATION ANY IMPLIED WARRANTIES OF MERCHANTABILITY, FITNESS FOR A PARTICULAR PURPOSE OR NON-INFRINGEMENT OF THIRD PARTY INTELLECTUAL PROPERTY RIGHTS.

These resources are intended for skilled developers designing with TI products. You are solely responsible for (1) selecting the appropriate TI products for your application, (2) designing, validating and testing your application, and (3) ensuring your application meets applicable standards, and any other safety, security, regulatory or other requirements.

These resources are subject to change without notice. TI grants you permission to use these resources only for development of an application that uses the TI products described in the resource. Other reproduction and display of these resources is prohibited. No license is granted to any other TI intellectual property right or to any third party intellectual property right. TI disclaims responsibility for, and you fully indemnify TI and its representatives against any claims, damages, costs, losses, and liabilities arising out of your use of these resources.

TI's products are provided subject to [TI's Terms of Sale](#), [TI's General Quality Guidelines](#), or other applicable terms available either on ti.com or provided in conjunction with such TI products. TI's provision of these resources does not expand or otherwise alter TI's applicable warranties or warranty disclaimers for TI products. Unless TI explicitly designates a product as custom or customer-specified, TI products are standard, catalog, general purpose devices.

TI objects to and rejects any additional or different terms you may propose.

Copyright © 2026, Texas Instruments Incorporated

Last updated 10/2025