

TRS3232 3-V to 5.5-V Multichannel RS-232 Line Driver and Receiver

With ± 15 -kV ESD Protection

1 Features

- RS-232 Bus-terminal ESD protection exceeds ± 15 kV using human-body model (HBM)
- Meets or exceeds the requirements of TIA/EIA-232-F and ITU V.28 standards
- Operates with 3-V to 5.5-V V_{CC} supply
- Operates up to 250 kbps
- Two drivers and two receivers
- Low supply current: 300- μ A typical
- External capacitors: $4 \times 0.1 \mu\text{F}$
- Accepts 5-V logic input with 3.3-V supply
- Alternative high-speed terminal-compatible devices (1 Mbps)
 - SN65C3232 (-40°C to 85°C)
 - SN75C3232 (0°C to 70°C)

2 Applications

- [Industrial PCs](#)
- [Wired networking](#)
- [Data center and enterprise computing](#)
- [Battery-powered systems](#)
- [Notebooks](#)
- [Laptops](#)
- [Palmtop PCs](#)
- [Hand-held equipment](#)

3 Description

The TRS3232 consists of two line drivers, two line receivers, and a dual charge-pump circuit with ± 15 -kV ESD protection terminal-to-terminal (serial-port connection terminals, including GND). The device meets the requirements of TIA/EIA-232-F and provides the electrical interface between an asynchronous communication controller and the serial-port connector. The charge pump and four small external capacitors allow operation from one 3-V to 5.5-V supply. The devices operate at data-signaling rates up to 250 kbps and a maximum of 30-V/ μs driver-output slew rate.

Device Information

| PART NUMBER | PACKAGE ⁽¹⁾ | BODY SIZE (NOM) |
|-------------|------------------------|---------------------------|
| TRS3232 | SOIC (16) | 9.90 mm \times 3.91 mm |
| | SSOP (16) | 6.20 mm \times 5.30 mm |
| | SOIC-Wide (16) | 10.30 mm \times 7.50 mm |
| | TSSOP (16) | 5.00 mm \times 4.40 mm |

(1) For all available packages, see the orderable addendum at the end of the data sheet.

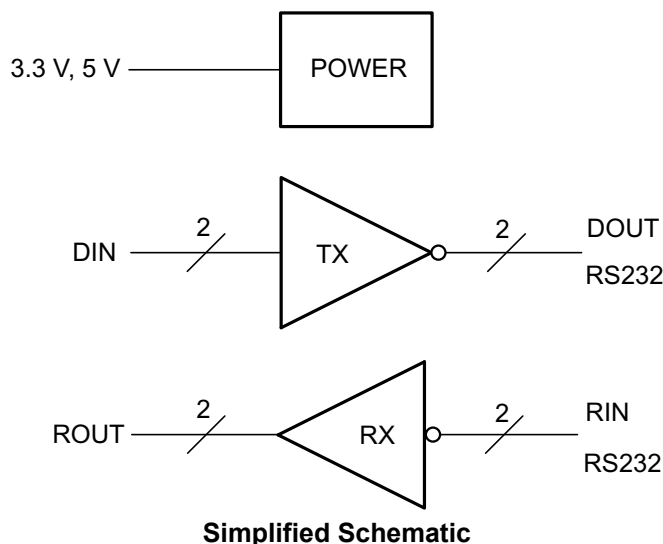

Table of Contents

| | | | |
|--|---|--|----|
| 1 Features | 1 | 8.2 Functional Block Diagram..... | 8 |
| 2 Applications | 1 | 8.3 Feature Description..... | 8 |
| 3 Description | 1 | 8.4 Device Functional Modes..... | 9 |
| 4 Revision History | 2 | 9 Application and Implementation | 10 |
| 5 Pin Configuration and Functions | 3 | 9.1 Application Information..... | 10 |
| 6 Specifications | 4 | 9.2 Typical Application..... | 10 |
| 6.1 Absolute Maximum Ratings..... | 4 | 10 Power Supply Recommendations | 11 |
| 6.2 ESD Ratings..... | 4 | 11 Layout | 12 |
| 6.3 Recommended Operating Conditions..... | 4 | 11.1 Layout Guidelines..... | 12 |
| 6.4 Thermal Information..... | 5 | 11.2 Layout Example..... | 12 |
| 6.5 Electrical Characteristics—Device..... | 5 | 12 Device and Documentation Support | 13 |
| 6.6 Electrical Characteristics—Driver..... | 5 | 12.1 Receiving Notification of Documentation Updates.. | 13 |
| 6.7 Electrical Characteristics—Receiver..... | 6 | 12.2 Support Resources..... | 13 |
| 6.8 Switching Characteristics..... | 6 | 12.3 Trademarks..... | 13 |
| 6.9 Typical Characteristics..... | 6 | 12.4 Electrostatic Discharge Caution..... | 13 |
| 7 Parameter Measurement Information | 7 | 12.5 Glossary..... | 13 |
| 8 Detailed Description | 8 | 13 Mechanical, Packaging, and Orderable Information | 13 |
| 8.1 Overview..... | 8 | | |

4 Revision History

NOTE: Page numbers for previous revisions may differ from page numbers in the current version.

Changes from Revision A (July 2015) to Revision B (June 2021) Page

- Added *Applications*: Industrial PCs, Wired networking, and Data center and enterprise computing..... 1
- Added additional thermal parameters for all packages in *Thermal Information* table..... 5

Changes from Revision * (July 2007) to Revision A (June 2015) Page

- Changed *Pin Functions* table, *ESD Ratings* table, *Thermal Information* table, *Typical Characteristics* section, *Detailed Description* section, *Power Supply Recommendations* and *Layout* sections, *Device and Documentation Support* and *Mechanical, Packaging, and Orderable Information* 1
- Deleted *Ordering Information* table..... 3

5 Pin Configuration and Functions

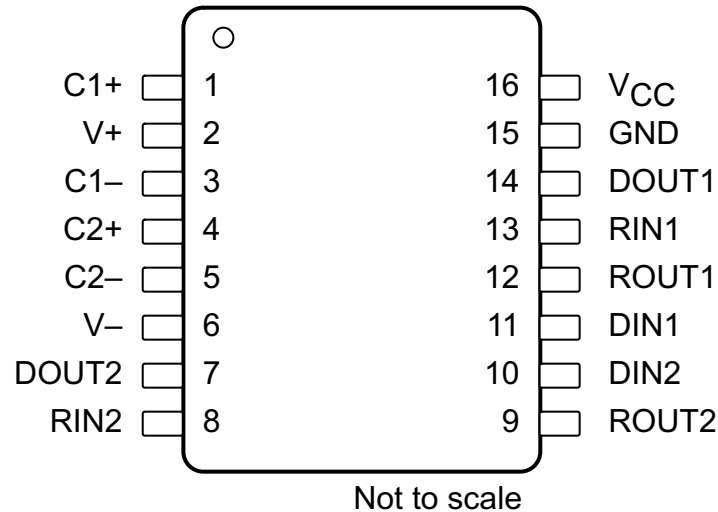

Figure 5-1. D, DB, DW, PW Packages 16-Pin SOIC, SSOP, SOIC (Wide), TSSOP Top View

Table 5-1. Pin Functions

| PIN | | TYPE | DESCRIPTION |
|-----------------|-----|------|---|
| NAME | NO. | | |
| C1+ | 1 | — | Positive lead of C1 capacitor |
| C1– | 3 | — | Negative lead of C1 capacitor |
| C2+ | 4 | — | Positive lead of C2 capacitor |
| C2– | 5 | — | Negative lead of C2 capacitor |
| DIN1 | 11 | I | Logic data input (from UART) |
| DIN2 | 10 | I | Logic data input (from UART) |
| DOUT1 | 14 | O | RS232 line data output (to remote RS232 system) |
| DOUT2 | 7 | O | RS232 line data output (to remote RS232 system) |
| GND | 15 | — | Ground |
| RIN1 | 13 | I | RS232 line data input (from remote RS232 system) |
| RIN2 | 8 | I | RS232 line data input (from remote RS232 system) |
| ROUT1 | 12 | O | Logic data output (to UART) |
| ROUT2 | 9 | O | Logic data output (to UART) |
| V+ | 2 | O | Positive charge pump output for storage capacitor only |
| V– | 6 | O | Negative charge pump output for storage capacitor only |
| V _{CC} | 16 | — | Supply Voltage, Connect to external 3-V to 5.5-V power supply |

6 Specifications

6.1 Absolute Maximum Ratings

over operating free-air temperature range (unless otherwise noted) ⁽¹⁾

| | | MIN | MAX | UNIT | |
|---------------------------------|---|-----------|-------|-----------------------|---|
| V _{CC} | Supply voltage ⁽²⁾ | -0.3 | 6 | V | |
| V ₊ | Positive output supply voltage ⁽²⁾ | -0.3 | 7 | V | |
| V ₋ | Negative output supply voltage ⁽²⁾ | -7 | 0.3 | V | |
| V ₊ - V ₋ | Supply voltage difference ⁽²⁾ | | 13 | V | |
| V _I | Input voltage | Drivers | -0.3 | 6 | V |
| | | Receivers | -25 | 25 | |
| V _O | Output voltage | Drivers | -13.2 | 13.2 | V |
| | | Receivers | -0.3 | V _{CC} + 0.3 | |
| T _J | Operating virtual junction temperature | | 150 | °C | |
| T _{stg} | Storage temperature | -65 | 150 | °C | |

- (1) Operation outside the *Absolute Maximum Ratings* may cause permanent device damage. *Absolute Maximum Ratings* do not imply functional operation of the device at these or any other conditions beyond those listed under *Recommended Operating Conditions*. If used outside the *Recommended Operating Conditions* but within the *Absolute Maximum Ratings*, the device may not be fully functional, and this may affect device reliability, functionality, performance, and shorten the device lifetime.
- (2) All voltages are with respect to network GND.

6.2 ESD Ratings

| | | VALUE | UNIT | |
|--------------------|-------------------------|---|--------|---|
| V _(ESD) | Electrostatic discharge | Human body model (HBM), per ANSI/ESDA/JEDEC JS-001 RIN, DOUT, and GND pins ⁽¹⁾ | ±15000 | V |
| | | Human body model (HBM), per ANSI/ESDA/JEDEC JS-001 All other pins ⁽¹⁾ | ±3000 | |
| | | Charged device model (CDM), per JEDEC specification JESD22-C101, all pins ⁽²⁾ | ±1000 | |

- (1) JEDEC document JEP155 states that 500-V HBM allows safe manufacturing with a standard ESD control process.
- (2) JEDEC document JEP157 states that 250-V CDM allows safe manufacturing with a standard ESD control process.

6.3 Recommended Operating Conditions

(see [Figure 9-1](#))⁽¹⁾

| | | MIN | NOM | MAX | UNIT | |
|-----------------|---------------------------------|-------------------------|-------------------------|-----|------|---|
| V _{CC} | Supply voltage | V _{CC} = 3.3 V | 3 | 3.3 | 3.6 | V |
| | | V _{CC} = 5 V | 4.5 | 5 | 5.5 | |
| V _{IH} | Driver high-level input voltage | DIN | V _{CC} = 3.3 V | 2 | | V |
| | | | V _{CC} = 5 V | 2.4 | | |
| V _{IL} | Driver low-level input voltage | DIN | | | 0.8 | V |
| V _I | Driver input voltage | DIN | 0 | 5.5 | V | |
| | Receiver input voltage | RIN | -25 | 25 | | |
| T _A | Operating free-air temperature | TRIS3232C | 0 | 70 | °C | |
| | | TRIS3232I | -40 | 85 | °C | |

- (1) Test conditions are C1–C4 = 0.1 μF at V_{CC} = 3.3 V ± 0.3 V; C1 = 0.047 μF, C2–C4 = 0.33 μF at V_{CC} = 5 V ± 0.5 V.

6.4 Thermal Information

| THERMAL METRIC ⁽¹⁾ | TRS3232 | | | | UNIT |
|---|-------------|--------------|-------------------|---------------|------|
| | D (SOIC) | DB (SSOP) | DW (SOIC-wide) | PW (TSSOP) | |
| | 16 PINS | 16 PINS | 16 PINS | 16 PINS | |
| $R_{\theta JA}$ Junction-to-ambient thermal resistance | 73 | 82 | 57 | 108 | °C/W |
| $R_{\theta JC(top)}$ Junction-to-case (bottom) thermal resistance | 38.5 | 45.8 | 32.4 | 39 | °C/W |
| $R_{\theta JB}$ Junction-to-board thermal resistance | 36.3 | 44.6 | 31.9 | 54.4 | °C/W |
| ψ_{JT} Junction-to-top characterization parameter | 8.0 | 11.1 | 8.4 | 3.3 | °C/W |
| ψ_{JB} Junction-to-board characterization parameter | 36.0 | 44 | 31.5 | 53.8 | °C/W |
| $R_{\theta JC(bot)}$ Junction-to-case (bottom) thermal resistance | N/A | N/A | N/A | N/A | °C/W |

- (1) For more information about traditional and new thermal metrics, see the *Semiconductor and IC Package Thermal Metrics* application report ([SPRA953](#)).

6.5 Electrical Characteristics—Device

over recommended ranges of supply voltage and operating free-air temperature (unless otherwise noted)⁽²⁾ (see [Figure 9-1](#))

| PARAMETER | TEST CONDITIONS | MIN | TYP ⁽¹⁾ | MAX | UNIT |
|-------------------------|--|-----|--------------------|-----|------|
| I_{CC} Supply current | No load, $V_{CC} = 3.3\text{ V to }5\text{ V}$ | | 0.3 | 1 | mA |

- (1) All typical values are at $V_{CC} = 3.3\text{ V}$ or $V_{CC} = 5\text{ V}$, and $T_A = 25^\circ\text{C}$.
 (2) Test conditions are $C1-C4 = 0.1\text{ }\mu\text{F}$ at $V_{CC} = 3.3\text{ V} \pm 0.3\text{ V}$; $C1 = 0.047\text{ }\mu\text{F}$, $C2-C4 = 0.33\text{ }\mu\text{F}$ at $V_{CC} = 5\text{ V} \pm 0.5\text{ V}$.

6.6 Electrical Characteristics—Driver

over recommended ranges of supply voltage and operating free-air temperature (unless otherwise noted)⁽¹⁾ (see [Figure 9-1](#))

| PARAMETER | TEST CONDITIONS | MIN | TYP ⁽²⁾ | MAX | UNIT |
|--|--|-----|--------------------|----------|---------------|
| V_{OH} High-level output voltage | D_{OUT} at $R_L = 3\text{ k}\Omega$ to GND, $D_{IN} = \text{GND}$ | 5 | 5.4 | | V |
| V_{OL} Low-level output voltage | D_{OUT} at $R_L = 3\text{ k}\Omega$ to GND, $D_{IN} = V_{CC}$ | -5 | -5.4 | | V |
| I_{IH} High-level input current | $V_I = V_{CC}$ | | ± 0.01 | ± 1 | μA |
| I_{IL} Low-level input current | V_I at GND | | ± 0.01 | ± 1 | μA |
| I_{OS} ⁽³⁾ Short-circuit output current | $V_{CC} = 3.6\text{ V}$ $V_O = 0\text{ V}$ | | ± 35 | ± 60 | mA |
| | $V_{CC} = 5.5\text{ V}$ $V_O = 0\text{ V}$ | | | | |
| r_O Output resistance | $V_{CC} = 0\text{ V}$, $V_+ = 0\text{ V}$, and $V_- = 0\text{ V}$ $V_O = \pm 2\text{ V}$ | 300 | 10M | | Ω |

- (1) Test conditions are $C1-C4 = 0.1\text{ }\mu\text{F}$ at $V_{CC} = 3.3\text{ V} \pm 0.3\text{ V}$; $C1 = 0.047\text{ }\mu\text{F}$, $C2-C4 = 0.33\text{ }\mu\text{F}$ at $V_{CC} = 5\text{ V} \pm 0.5$
 (2) All typical values are at $V_{CC} = 3.3\text{ V}$ or $V_{CC} = 5\text{ V}$, and $T_A = 25^\circ\text{C}$.
 (3) Short-circuit durations should be controlled to prevent exceeding the device absolute power dissipation ratings, and not more than one output should be shorted at a time.

6.7 Electrical Characteristics—Receiver

over recommended ranges of supply voltage and operating free-air temperature (unless otherwise noted)⁽¹⁾ (see Figure 9-1)

| PARAMETER | | TEST CONDITIONS | MIN | TYP ⁽²⁾ | MAX | UNIT |
|------------------|---|--------------------------------|-----------------------|-----------------------|-----|------|
| V _{OH} | High-level output voltage | I _{OH} = -1 mA | V _{CC} - 0.6 | V _{CC} - 0.1 | | V |
| V _{OL} | Low-level output voltage | I _{OL} = 1.6 mA | | | 0.4 | V |
| V _{IT+} | Positive-going input threshold voltage | V _{CC} = 3.3 V | | 1.5 | 2.4 | V |
| | | V _{CC} = 5 V | | 1.8 | 2.4 | |
| V _{IT-} | Negative-going input threshold voltage | V _{CC} = 3.3 V | 0.6 | 1.2 | | V |
| | | V _{CC} = 5 V | 0.8 | 1.5 | | |
| V _{hys} | Input hysteresis (V _{IT+} - V _{IT-}) | | | 0.3 | | V |
| r _I | Input resistance | V _I = ±3 V to ±25 V | 3 | 5 | 7 | kΩ |

(1) Test conditions are C1–C4 = 0.1 μF at V_{CC} = 3.3 V ± 0.3 V; C1 = 0.047 μF, C2–C4 = 0.33 μF at V_{CC} = 5 V ± 0.5 V.

(2) All typical values are at V_{CC} = 3.3 V or V_{CC} = 5 V, and T_A = 25°C.

6.8 Switching Characteristics

over recommended ranges of supply voltage and operating free-air temperature (unless otherwise noted)⁽¹⁾ (see Figure 9-1)

| PARAMETER | | TEST CONDITIONS | MIN | TYP ⁽²⁾ | MAX | UNIT |
|--------------------|---|---|---------------------------------|--------------------|-----|------|
| | Maximum data rate | R _L = 3 kΩ, C _L = 1000 pF One D _{OUT} switching, See Figure 7-1 | 150 | 250 | | kbps |
| t _{sk(p)} | Driver Pulse skew ⁽³⁾ | R _L = 3 kΩ to 7 kΩ, C _L = 150 to 2500 pF See Figure 7-2 | | 300 | | ns |
| SR(tr) | Driver Slew rate, transition region (see Figure 7-1) | R _L = 3 kΩ to 7 kΩ, V _{CC} = 5 V | C _L = 150 to 1000 pF | 6 | 30 | V/μs |
| | | | C _L = 150 to 2500 pF | 4 | 30 | |
| t _{PLH} | Receiver Propagation delay time, low-to-high-level output | C _L = 150 pF | | 300 | | ns |
| t _{PHL} | Receiver Propagation delay time, high-to-low-level output | | | 300 | | ns |
| t _{sk(p)} | Receiver Pulse skew ⁽¹⁾ | | | 300 | | ns |

(1) Test conditions are C1–C4 = 0.1 μF at V_{CC} = 3.3 V ± 0.3 V; C1 = 0.047 μF, C2–C4 = 0.33 μF at V_{CC} = 5 V ± 0.5 V.

(2) All typical values are at V_{CC} = 3.3 V or V_{CC} = 5 V, and T_A = 25°C.

(3) Pulse skew is defined as |t_{PLH} - t_{PHL}| of each channel of the same device.

6.9 Typical Characteristics

V_{CC} = 3.3 V

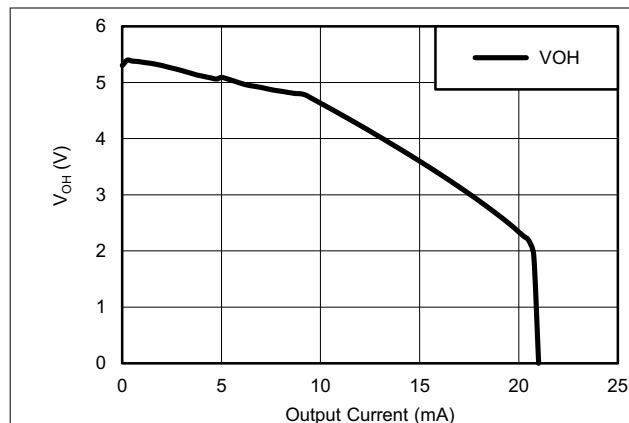

Figure 6-1. DOUT V_{OH} vs Load Current, Both Drivers Loaded

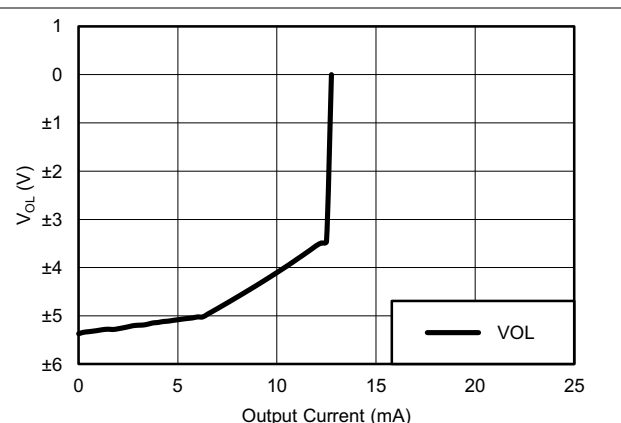
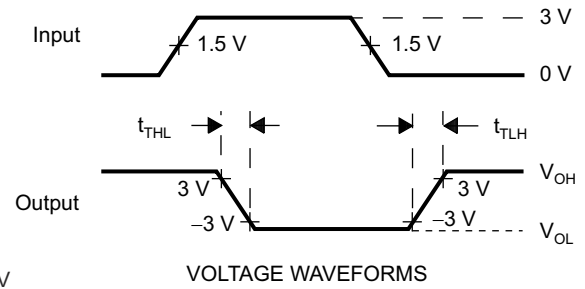
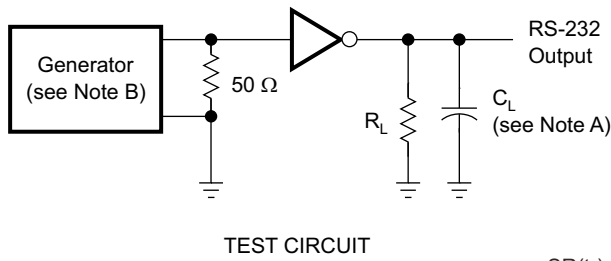

Figure 6-2. DOUT V_{OL} vs Load Current, Both Drivers Loaded

7 Parameter Measurement Information



$$SR(tr) = \frac{6\text{ V}}{t_{THL} \text{ or } t_{TLH}}$$

- A. C_L includes probe and jig capacitance.
- B. The pulse generator has the following characteristics: PRR = 250 kbps, $Z_O = 50\ \Omega$, 50% duty cycle, $t_r \leq 10\text{ ns}$, $t_f \leq 10\text{ ns}$.

Figure 7-1. Driver Slew Rate

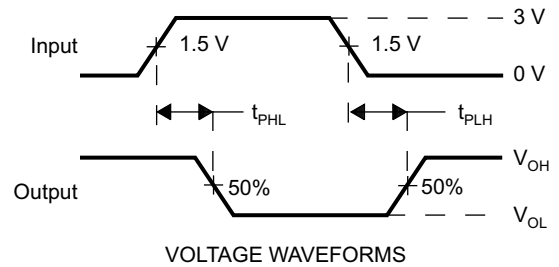
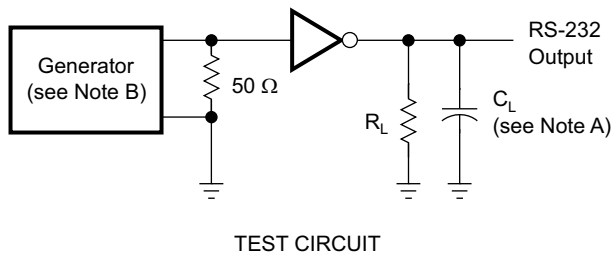

- A. C_L includes probe and jig capacitance.
- B. The pulse generator has the following characteristics: PRR = 250 kbps, $Z_O = 50\ \Omega$, 50% duty cycle, $t_r \leq 10\text{ ns}$, $t_f \leq 10\text{ ns}$.

Figure 7-2. Driver Pulse Skew

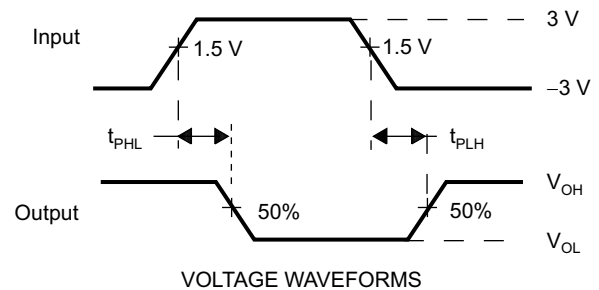
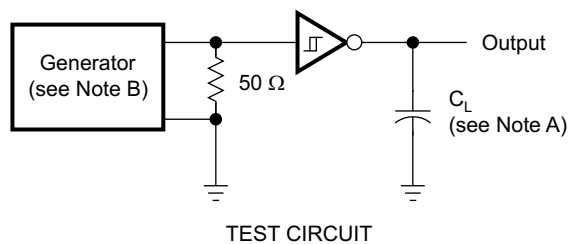

- A. C_L includes probe and jig capacitance.
- B. The pulse generator has the following characteristics: $Z_O = 50\ \Omega$, 50% duty cycle, $t_r \leq 10\text{ ns}$, $t_f \leq 10\text{ ns}$.

Figure 7-3. Receiver Propagation Delay Times

8 Detailed Description

8.1 Overview

The TRIS3232 device consists of two line drivers, two line receivers, and a dual charge-pump circuit with ± 15 -kV ESD protection terminal to terminal (serial-port connection terminals, including GND). The device meets the requirements of TIA/EIA-232-F and provides the electrical interface between an asynchronous communication controller and the serial-port connector. The charge pump and four small external capacitors allow operation from one 3-V to 5.5-V supply. The device operates at data signaling rates up to 250 kbps and a maximum of 30-V/ μ s driver output slew rate. Outputs are protected against shorts to ground.

8.2 Functional Block Diagram

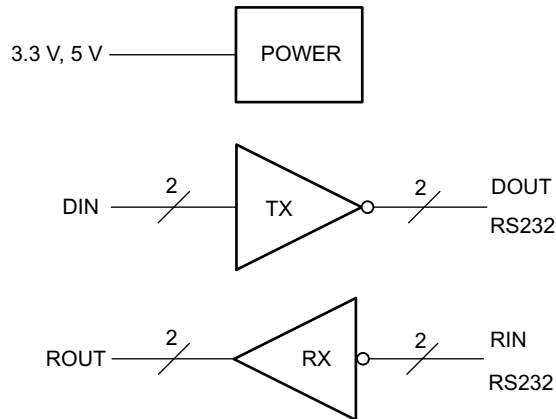

8.3 Feature Description

8.3.1 Power

The power block increases, inverts, and regulates voltage at V_+ and V_- pins using a charge pump that requires four external capacitors.

8.3.2 RS232 Driver

Two drivers interface the standard logic level to RS232 levels. Both DIN inputs must be valid high or low.

8.3.3 RS232 Receiver

Two receivers interface RS232 levels to standard logic levels. An open input results in a high output on ROUT. Each RIN input includes an internal standard RS232 load.

8.4 Device Functional Modes

Table 8-1. Each Driver

| INPUT DIN ⁽¹⁾ | OUTPUT DOUT |
|--------------------------|-------------|
| L | H |
| H | L |

(1) H = high level, L = low level

Table 8-2. Each Receiver

| INPUT RIN ⁽¹⁾ | OUTPUT ROUT |
|--------------------------|-------------|
| L | H |
| H | L |
| Open | H |

(1) H = high level, L = low level,
Open = input disconnected or connected driver off

8.4.1 V_{CC} Powered by 3 V to 5.5 V

The device is in normal operation.

8.4.2 V_{CC} Unpowered, V_{CC} = 0 V

When the TRS3232 device is unpowered, it can be safely connected to an active remote RS232 device.

9 Application and Implementation

Note

Information in the following applications sections is not part of the TI component specification, and TI does not warrant its accuracy or completeness. TI's customers are responsible for determining suitability of components for their purposes, as well as validating and testing their design implementation to confirm system functionality.

9.1 Application Information

The TRS3232 is designed to convert single-ended signals into RS232-compatible signals, and vice-versa.

This device can be used in any application where an RS232 line driver or receiver is required. One benefit of this device is its ESD protection, which helps protect other components on the board when the RS232 lines are tied to a physical connector.

9.2 Typical Application

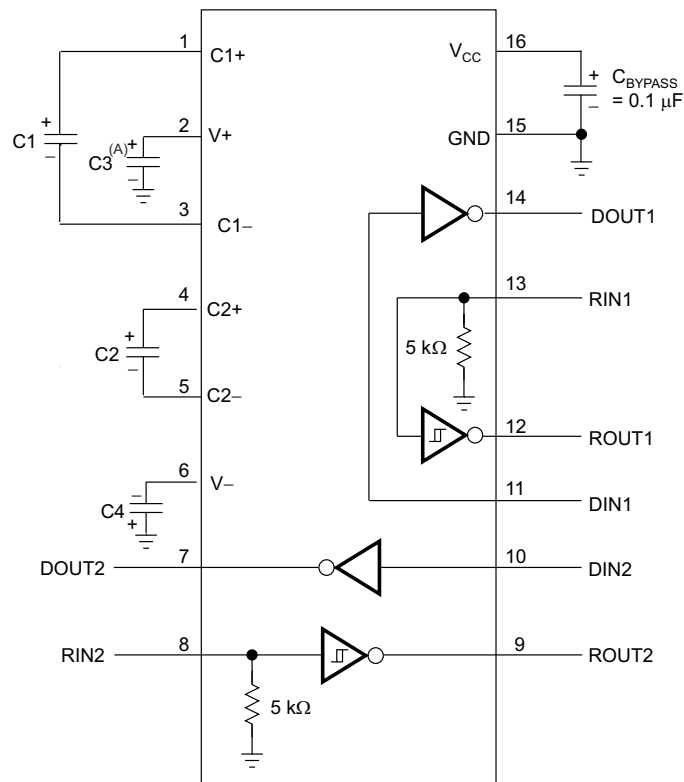

- A. C3 can be connected to V_{CC} or GND.
- B. Resistor values shown are nominal.
- C. Nonpolarized ceramic capacitors are acceptable. If polarized tantalum or electrolytic capacitors are used, they must be connected as shown.
- D. See [Table 9-1](#) for capacitor values.

Figure 9-1. Typical Operating Circuit

9.2.1 Design Requirements

- Recommended V_{CC} is 3.3 V or 5 V
 - 3 V to 5.5 V is also possible
- Maximum recommended bit rate is 250 kbites

Table 9-1. V_{CC} versus Capacitor Values

| V_{CC} | C1 | C2, C3, C4 |
|-------------------|---------------|--------------|
| 3.3 V \pm 0.3 V | 0.1 μ F | 0.1 μ F |
| 5 V \pm 0.5 V | 0.047 μ F | 0.33 μ F |
| 3 V to 5.5 V | 0.1 μ F | 0.47 μ F |

9.2.2 Detailed Design Procedure

For proper operation, add capacitors as shown in [Figure 9-1](#) and [Table 9-1](#).

All DIN inputs must be connected to valid low or high logic levels.

Select capacitor values based on V_{CC} level for best performance.

9.2.3 Application Curve

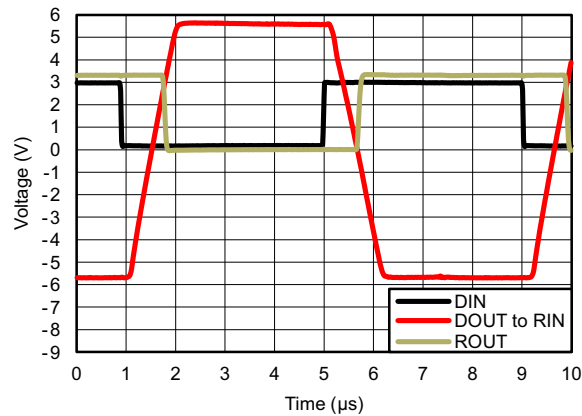

Figure 9-2. 250 kbps Driver to Receiver Loopback Timing Waveform, V_{CC} = 3.3 V

10 Power Supply Recommendations

V_{CC} must be between 3 V and 5.5 V. Charge pump capacitors must be chosen using [Table 9-1](#).

11 Layout

11.1 Layout Guidelines

Keep the external capacitor traces short. This is more important on C1 and C2 nodes that have the fastest rise and fall times.

11.2 Layout Example

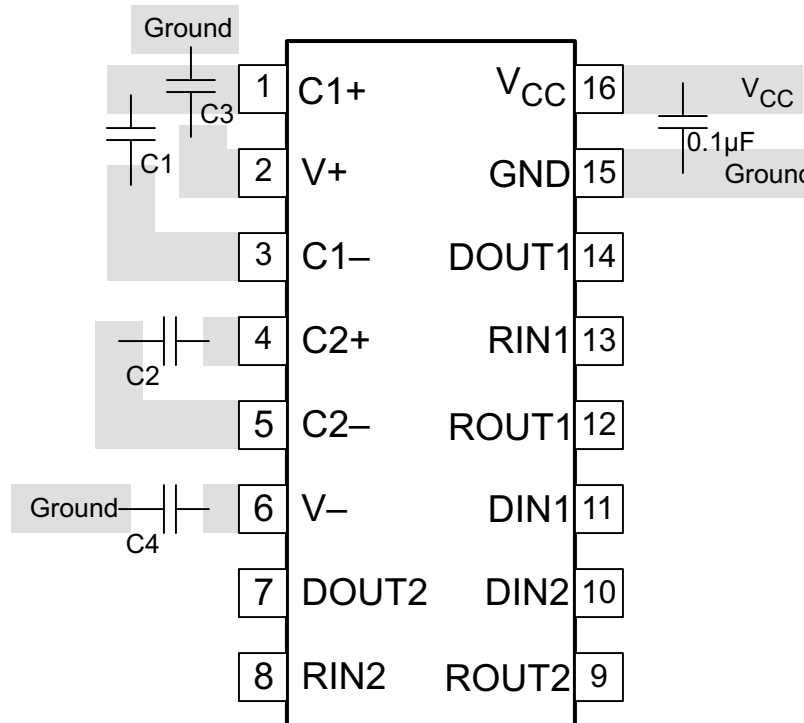

Figure 11-1. Layout Diagram

12 Device and Documentation Support

12.1 Receiving Notification of Documentation Updates

To receive notification of documentation updates, navigate to the device product folder on ti.com. Click on *Subscribe to updates* to register and receive a weekly digest of any product information that has changed. For change details, review the revision history included in any revised document.

12.2 Support Resources

[TI E2E™ support forums](#) are an engineer's go-to source for fast, verified answers and design help — straight from the experts. Search existing answers or ask your own question to get the quick design help you need.

Linked content is provided "AS IS" by the respective contributors. They do not constitute TI specifications and do not necessarily reflect TI's views; see TI's [Terms of Use](#).

12.3 Trademarks

TI E2E™ is a trademark of Texas Instruments.

All trademarks are the property of their respective owners.

12.4 Electrostatic Discharge Caution



This integrated circuit can be damaged by ESD. Texas Instruments recommends that all integrated circuits be handled with appropriate precautions. Failure to observe proper handling and installation procedures can cause damage.

ESD damage can range from subtle performance degradation to complete device failure. Precision integrated circuits may be more susceptible to damage because very small parametric changes could cause the device not to meet its published specifications.

12.5 Glossary

[TI Glossary](#) This glossary lists and explains terms, acronyms, and definitions.

13 Mechanical, Packaging, and Orderable Information

The following pages include mechanical, packaging, and orderable information. This information is the most current data available for the designated devices. This data is subject to change without notice and revision of this document. For browser-based versions of this data sheet, refer to the left-hand navigation.

PACKAGING INFORMATION

| Orderable Device | Status (1) | Package Type | Package Drawing | Pins | Package Qty | Eco Plan (2) | Lead finish/ Ball material (6) | MSL Peak Temp (3) | Op Temp (°C) | Device Marking (4/5) | Samples |
|------------------|---------------|--------------|-----------------|------|-------------|-----------------|--------------------------------------|----------------------|--------------|-------------------------|---------|
| TRS3232CDBR | OBSOLETE | SSOP | DB | 16 | | TBD | Call TI | Call TI | 0 to 70 | RS32C | |
| TRS3232CDR | OBSOLETE | SOIC | D | 16 | | TBD | Call TI | Call TI | 0 to 70 | TRS3232C | |
| TRS3232CDWR | OBSOLETE | SOIC | DW | 16 | | TBD | Call TI | Call TI | 0 to 70 | TRS3232C | |
| TRS3232IDR | OBSOLETE | SOIC | D | 16 | | TBD | Call TI | Call TI | -40 to 85 | TRS3232I | |
| TRS3232IPWR | ACTIVE | TSSOP | PW | 16 | 2000 | RoHS & Green | NIPDAU | Level-1-260C-UNLIM | -40 to 85 | RS32I | Samples |

(1) The marketing status values are defined as follows:

ACTIVE: Product device recommended for new designs.

LIFEBUY: TI has announced that the device will be discontinued, and a lifetime-buy period is in effect.

NRND: Not recommended for new designs. Device is in production to support existing customers, but TI does not recommend using this part in a new design.

PREVIEW: Device has been announced but is not in production. Samples may or may not be available.

OBSOLETE: TI has discontinued the production of the device.

(2) **RoHS:** TI defines "RoHS" to mean semiconductor products that are compliant with the current EU RoHS requirements for all 10 RoHS substances, including the requirement that RoHS substance do not exceed 0.1% by weight in homogeneous materials. Where designed to be soldered at high temperatures, "RoHS" products are suitable for use in specified lead-free processes. TI may reference these types of products as "Pb-Free".

RoHS Exempt: TI defines "RoHS Exempt" to mean products that contain lead but are compliant with EU RoHS pursuant to a specific EU RoHS exemption.

Green: TI defines "Green" to mean the content of Chlorine (Cl) and Bromine (Br) based flame retardants meet JS709B low halogen requirements of <=1000ppm threshold. Antimony trioxide based flame retardants must also meet the <=1000ppm threshold requirement.

(3) MSL, Peak Temp. - The Moisture Sensitivity Level rating according to the JEDEC industry standard classifications, and peak solder temperature.

(4) There may be additional marking, which relates to the logo, the lot trace code information, or the environmental category on the device.

(5) Multiple Device Markings will be inside parentheses. Only one Device Marking contained in parentheses and separated by a "-" will appear on a device. If a line is indented then it is a continuation of the previous line and the two combined represent the entire Device Marking for that device.

(6) Lead finish/Ball material - Orderable Devices may have multiple material finish options. Finish options are separated by a vertical ruled line. Lead finish/Ball material values may wrap to two lines if the finish value exceeds the maximum column width.

Important Information and Disclaimer: The information provided on this page represents TI's knowledge and belief as of the date that it is provided. TI bases its knowledge and belief on information provided by third parties, and makes no representation or warranty as to the accuracy of such information. Efforts are underway to better integrate information from third parties. TI has taken and continues to take reasonable steps to provide representative and accurate information but may not have conducted destructive testing or chemical analysis on incoming materials and chemicals. TI and TI suppliers consider certain information to be proprietary, and thus CAS numbers and other limited information may not be available for release.

In no event shall TI's liability arising out of such information exceed the total purchase price of the TI part(s) at issue in this document sold by TI to Customer on an annual basis.

TAPE AND REEL INFORMATION

QUADRANT ASSIGNMENTS FOR PIN 1 ORIENTATION IN TAPE

*All dimensions are nominal

| Device | Package Type | Package Drawing | Pins | SPQ | Reel Diameter (mm) | Reel Width W1 (mm) | A0 (mm) | B0 (mm) | K0 (mm) | P1 (mm) | W (mm) | Pin1 Quadrant |
|-------------|--------------|-----------------|------|------|--------------------|--------------------|---------|---------|---------|---------|--------|---------------|
| TRS3232IPWR | TSSOP | PW | 16 | 2000 | 330.0 | 12.4 | 6.9 | 5.6 | 1.6 | 8.0 | 12.0 | Q1 |
| TRS3232IPWR | TSSOP | PW | 16 | 2000 | 330.0 | 12.4 | 6.9 | 5.6 | 1.6 | 8.0 | 12.0 | Q1 |

TAPE AND REEL BOX DIMENSIONS

*All dimensions are nominal

| Device | Package Type | Package Drawing | Pins | SPQ | Length (mm) | Width (mm) | Height (mm) |
|-------------|--------------|-----------------|------|------|-------------|------------|-------------|
| TRS3232IPWR | TSSOP | PW | 16 | 2000 | 356.0 | 356.0 | 35.0 |
| TRS3232IPWR | TSSOP | PW | 16 | 2000 | 356.0 | 356.0 | 35.0 |

D (R-PDSO-G16)

PLASTIC SMALL OUTLINE



- NOTES:
- A. All linear dimensions are in inches (millimeters).
 - B. This drawing is subject to change without notice.
 - C. Body length does not include mold flash, protrusions, or gate burrs. Mold flash, protrusions, or gate burrs shall not exceed 0.006 (0,15) each side.
 - D. Body width does not include interlead flash. Interlead flash shall not exceed 0.017 (0,43) each side.
 - E. Reference JEDEC MS-012 variation AC.



4220204/A 02/2017

NOTES:

1. All linear dimensions are in millimeters. Any dimensions in parenthesis are for reference only. Dimensioning and tolerancing per ASME Y14.5M.
2. This drawing is subject to change without notice.
3. This dimension does not include mold flash, protrusions, or gate burrs. Mold flash, protrusions, or gate burrs shall not exceed 0.15 mm per side.
4. This dimension does not include interlead flash. Interlead flash shall not exceed 0.25 mm per side.
5. Reference JEDEC registration MO-153.

EXAMPLE BOARD LAYOUT

PW0016A

TSSOP - 1.2 mm max height

SMALL OUTLINE PACKAGE



LAND PATTERN EXAMPLE
EXPOSED METAL SHOWN
SCALE: 10X



SOLDER MASK DETAILS

4220204/A 02/2017

NOTES: (continued)

- 6. Publication IPC-7351 may have alternate designs.
- 7. Solder mask tolerances between and around signal pads can vary based on board fabrication site.

EXAMPLE STENCIL DESIGN

PW0016A

TSSOP - 1.2 mm max height

SMALL OUTLINE PACKAGE



SOLDER PASTE EXAMPLE
BASED ON 0.125 mm THICK STENCIL
SCALE: 10X

4220204/A 02/2017

NOTES: (continued)

8. Laser cutting apertures with trapezoidal walls and rounded corners may offer better paste release. IPC-7525 may have alternate design recommendations.
9. Board assembly site may have different recommendations for stencil design.

DB0016A



PACKAGE OUTLINE

SSOP - 2 mm max height

SMALL OUTLINE PACKAGE



NOTES:

1. All linear dimensions are in millimeters. Any dimensions in parenthesis are for reference only. Dimensioning and tolerancing per ASME Y14.5M.
2. This drawing is subject to change without notice.
3. This dimension does not include mold flash, protrusions, or gate burrs. Mold flash, protrusions, or gate burrs shall not exceed 0.15 mm per side.
4. Reference JEDEC registration MO-150.

EXAMPLE BOARD LAYOUT

DB0016A

SSOP - 2 mm max height

SMALL OUTLINE PACKAGE



LAND PATTERN EXAMPLE
EXPOSED METAL SHOWN
SCALE: 10X



4220763/A 05/2022

NOTES: (continued)

- 5. Publication IPC-7351 may have alternate designs.
- 6. Solder mask tolerances between and around signal pads can vary based on board fabrication site.

EXAMPLE STENCIL DESIGN

DB0016A

SSOP - 2 mm max height

SMALL OUTLINE PACKAGE



SOLDER PASTE EXAMPLE
BASED ON 0.125 mm THICK STENCIL
SCALE: 10X

4220763/A 05/2022

NOTES: (continued)

7. Laser cutting apertures with trapezoidal walls and rounded corners may offer better paste release. IPC-7525 may have alternate design recommendations.
8. Board assembly site may have different recommendations for stencil design.

GENERIC PACKAGE VIEW

DW 16

SOIC - 2.65 mm max height

7.5 x 10.3, 1.27 mm pitch

SMALL OUTLINE INTEGRATED CIRCUIT

This image is a representation of the package family, actual package may vary.
Refer to the product data sheet for package details.



4224780/A

IMPORTANT NOTICE AND DISCLAIMER

TI PROVIDES TECHNICAL AND RELIABILITY DATA (INCLUDING DATA SHEETS), DESIGN RESOURCES (INCLUDING REFERENCE DESIGNS), APPLICATION OR OTHER DESIGN ADVICE, WEB TOOLS, SAFETY INFORMATION, AND OTHER RESOURCES "AS IS" AND WITH ALL FAULTS, AND DISCLAIMS ALL WARRANTIES, EXPRESS AND IMPLIED, INCLUDING WITHOUT LIMITATION ANY IMPLIED WARRANTIES OF MERCHANTABILITY, FITNESS FOR A PARTICULAR PURPOSE OR NON-INFRINGEMENT OF THIRD PARTY INTELLECTUAL PROPERTY RIGHTS.

These resources are intended for skilled developers designing with TI products. You are solely responsible for (1) selecting the appropriate TI products for your application, (2) designing, validating and testing your application, and (3) ensuring your application meets applicable standards, and any other safety, security, regulatory or other requirements.

These resources are subject to change without notice. TI grants you permission to use these resources only for development of an application that uses the TI products described in the resource. Other reproduction and display of these resources is prohibited. No license is granted to any other TI intellectual property right or to any third party intellectual property right. TI disclaims responsibility for, and you will fully indemnify TI and its representatives against, any claims, damages, costs, losses, and liabilities arising out of your use of these resources.

TI's products are provided subject to [TI's Terms of Sale](#) or other applicable terms available either on [ti.com](https://www.ti.com) or provided in conjunction with such TI products. TI's provision of these resources does not expand or otherwise alter TI's applicable warranties or warranty disclaimers for TI products.

TI objects to and rejects any additional or different terms you may have proposed.

Mailing Address: Texas Instruments, Post Office Box 655303, Dallas, Texas 75265
Copyright © 2024, Texas Instruments Incorporated