



ABSTRACT

This document serves to accompany the design files for the ROTATEPUSH-MAG-ACC attachment for the magnetic sensing evaluation kits (EVMs) that interface with [TI-SCB](#) such as the [TMAG5170UEVM](#). In addition to this guide, the design files are provided as an example and may be used in a 3D printer to generate a demonstration of common functions of angle measurement and push button functionality using a three-dimensional Hall-effect sensor.

Note

Design files described in this document can be downloaded from [Rotate and Push Module design files](#).

Table of Contents

1 Introduction	2
2 Assembly Guide	3

Trademarks

All trademarks are the property of their respective owners.

1 Introduction

This ROTATEPUSH-MAG-ACC attachment uses an N42 grade cylindrical magnet as a magnetic field source to demonstrate the ability of magnetic sensors to track rotational and push button motion of a nearby magnet. The magnet is glued into a 3D-printed knob object, which can rotate freely about the 3D-printed base. The knob can also be pressed and return back to the starting position due to the spring. More details about this function are described in [Using Hall-Effect Sensors for Contactless Rotary Encoding and Knob Applications](#) and [3D Hall-Effect Sensor for Knobs in Appliances](#).

Examples of expected magnetic field data captured using the [TMAG5173EVM](#) are shown in [Figure 1-1](#).

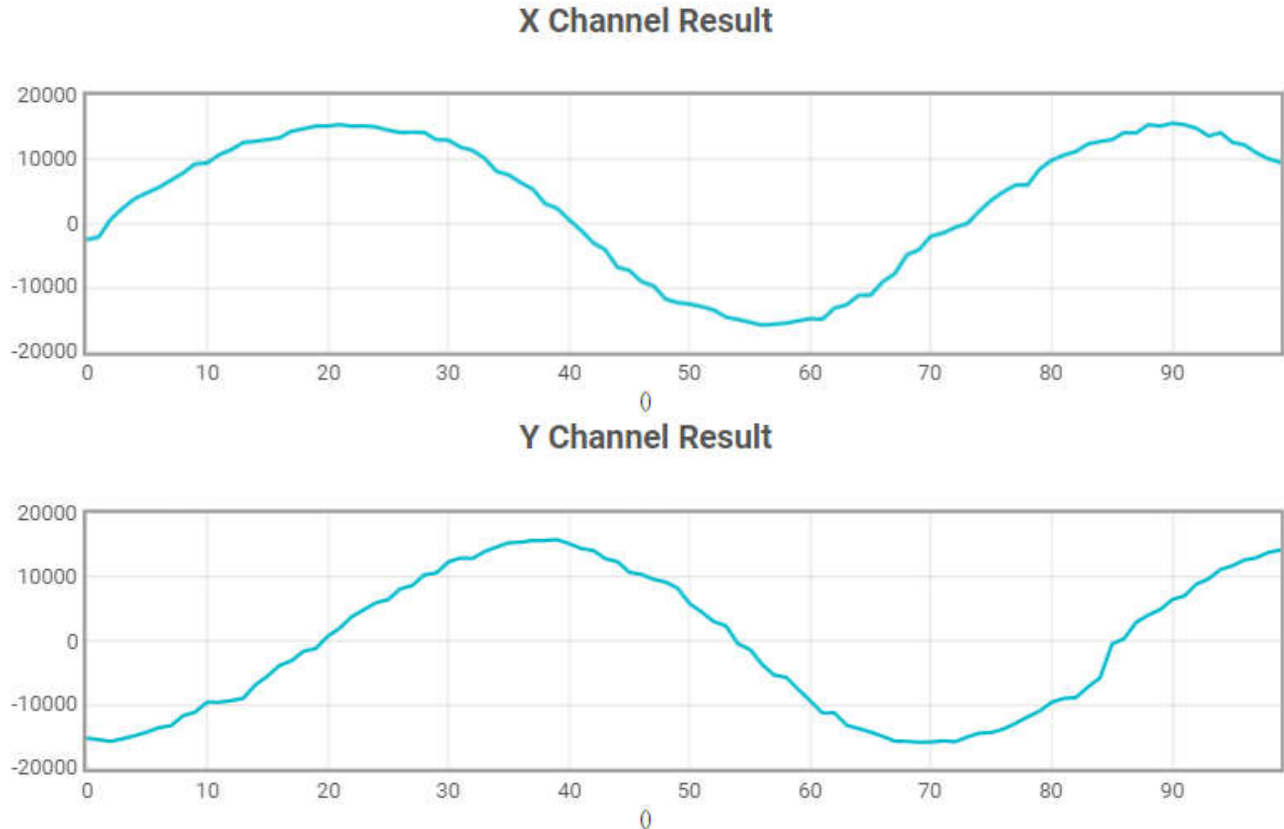

Figure 1-1. Example Rotation Output with On-Axis Alignment

Nylon components were selected as these components are non-magnetic and do not interfere with the magnetic field and bond well when glued.



Figure 1-2. ROTATEPUSH-MAG-ACC Attachment

This function can be further explored using the angle encoding reference design in the TI Magnetic Sense Simulator tool (TIMSS) available at <https://webench.ti.com/timss/>.

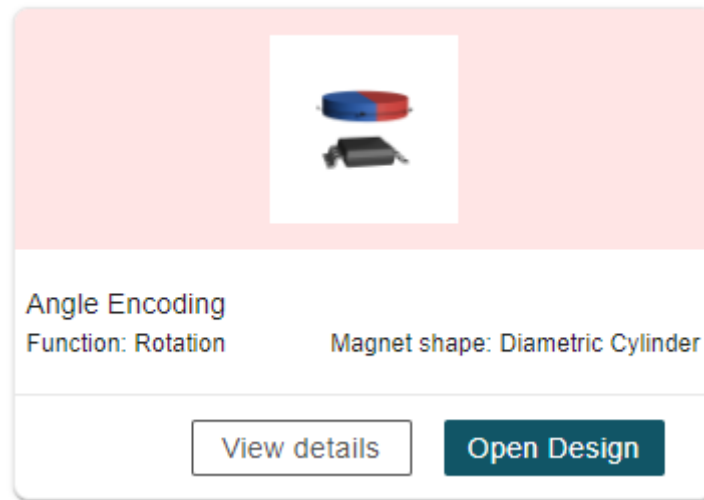

Figure 1-3. TIMSS Angle Encoding Reference Design

2 Assembly Guide

ROTATEPUSH-MAG-ACC kits ordered from TI.com come pre-assembled, but in cases where the kit is printed locally, follow steps described below.

Item	Description	Quantity
Knob	FnlKnob100.STL	1
Base	Base_NoPedestal_8p25mmCollar.STL	1
1/2" dia. x 1/8" thick, N42 diametric magnet	NdFeB (N42): available at K&J Magnetics	1
Spring	Compression spring available at The Spring Store	1
8333-20G	Super Glue	0.02oz

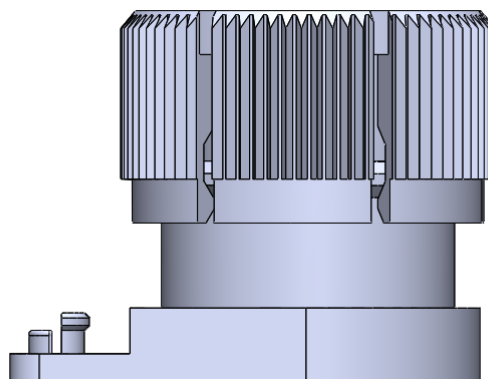

Figure 2-1. Complete Knob Assembly

1. Print the knob (FnlKnob100.STL).

This piece carries the magnet and provides a grip to control the magnet rotation and push function about the base.

2. Glue the magnet into the bottom of the knob.

Glue the magnet into the knob. The magnet should seat flush with the bottom of the knob.



Figure 2-2. Knob with Magnet

3. Place the spring in the back side of the knob



Figure 2-3. Knob with Magnet and Spring

4. Print the base (Base_NoPedestal_8p25mmCollar.STL).

This is the central fixture of the assembly. The knob track clips to the base, then the base clips into the EVM to allow the magnet to rotate and push above the sensor.

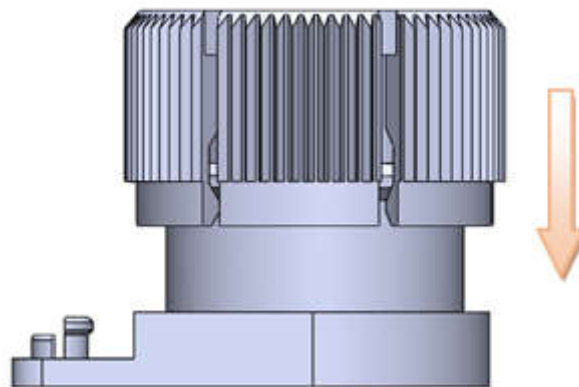

Figure 2-4. Attach Knob to Base

5. Attach the rotate and push module to the magnetic-sensing EVM.

Slide the platform end of the EVM underneath the window in the knob, and align the cut holes in the EVM above the circular clips in the track base. Apply some downward force to clip the EVM into the track base. The first insertion may require more effort, but subsequent insertions should snap easily. When the base is attached to the EVM, rotate or push the knob as desired.

Connect the EVM to the [TI-SCB](#) and follow the relevant instructions to program the device provided in the device-specific EVM user's guide.

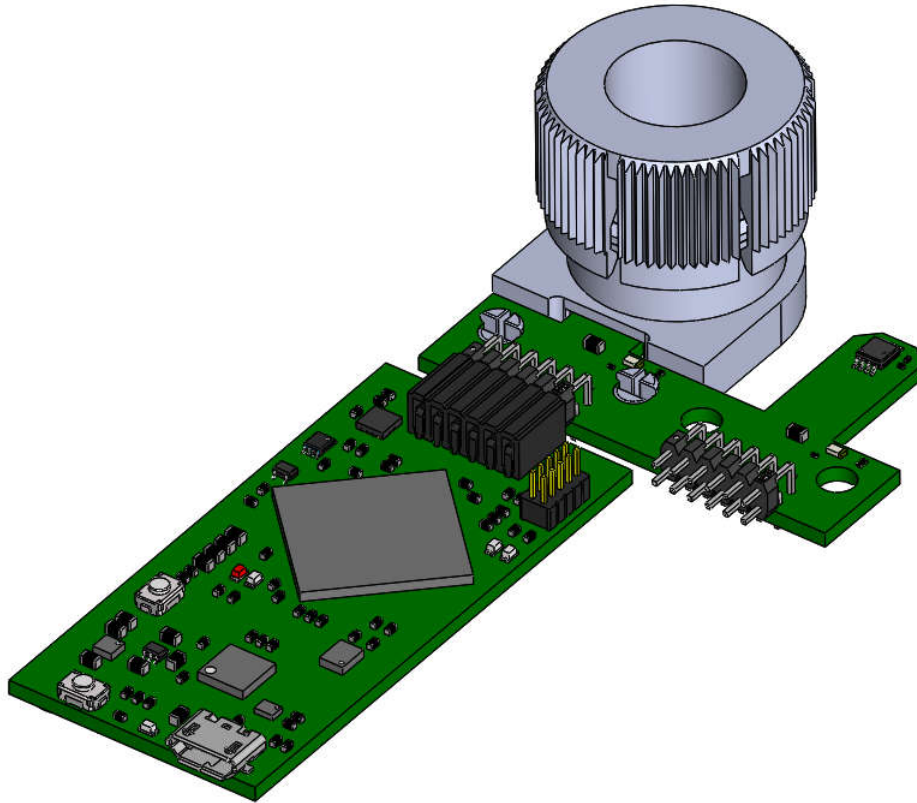

Figure 2-5. EVM Attach

IMPORTANT NOTICE AND DISCLAIMER

TI PROVIDES TECHNICAL AND RELIABILITY DATA (INCLUDING DATA SHEETS), DESIGN RESOURCES (INCLUDING REFERENCE DESIGNS), APPLICATION OR OTHER DESIGN ADVICE, WEB TOOLS, SAFETY INFORMATION, AND OTHER RESOURCES "AS IS" AND WITH ALL FAULTS, AND DISCLAIMS ALL WARRANTIES, EXPRESS AND IMPLIED, INCLUDING WITHOUT LIMITATION ANY IMPLIED WARRANTIES OF MERCHANTABILITY, FITNESS FOR A PARTICULAR PURPOSE OR NON-INFRINGEMENT OF THIRD PARTY INTELLECTUAL PROPERTY RIGHTS.

These resources are intended for skilled developers designing with TI products. You are solely responsible for (1) selecting the appropriate TI products for your application, (2) designing, validating and testing your application, and (3) ensuring your application meets applicable standards, and any other safety, security, regulatory or other requirements.

These resources are subject to change without notice. TI grants you permission to use these resources only for development of an application that uses the TI products described in the resource. Other reproduction and display of these resources is prohibited. No license is granted to any other TI intellectual property right or to any third party intellectual property right. TI disclaims responsibility for, and you will fully indemnify TI and its representatives against, any claims, damages, costs, losses, and liabilities arising out of your use of these resources.

TI's products are provided subject to [TI's Terms of Sale](#) or other applicable terms available either on [ti.com](https://www.ti.com) or provided in conjunction with such TI products. TI's provision of these resources does not expand or otherwise alter TI's applicable warranties or warranty disclaimers for TI products.

TI objects to and rejects any additional or different terms you may have proposed.

Mailing Address: Texas Instruments, Post Office Box 655303, Dallas, Texas 75265
Copyright © 2024, Texas Instruments Incorporated