

Application Note

LC Filter Design



Jennifer Bruzon

ABSTRACT

In higher-power class-D amplifiers, generally above 10 W of output power, a filter on the output of the amplifier is required. The filter is passive in nature and uses both an inductor and a capacitor on each output terminal. Therefore, it is referred to as an LC filter. Proper component selection of the LC filter is critical to meet the desired audio performance, efficiency, EMC/EMI requirements, and cost for the end application. This application report serves as a guide to aid in the selection of LC filter components for class-D amplifiers to meet target-design goals of the end system

Table of Contents

1 LC Filter Design	2
1.1 Class-D Output Configurations.....	2
1.2 Class-D Modulation Schemes.....	4
1.3 Class-D Output LC Filter.....	7
1.4 Inductor Selection for High-Performance Class-D Audio.....	19
1.5 Capacitor Considerations.....	29
1.6 Related Collateral.....	41
2 Reference	42
3 Reference	43
4 Revision History	44

Trademarks

Coilcraft™ is a trademark of Coilcraft, Inc.
All trademarks are the property of their respective owners.

1 LC Filter Design

In higher-power class-D amplifiers, generally above 10 W of output power, a filter on the output of the amplifier is required. The filter is passive in nature and uses both an inductor and a capacitor on each output terminal. Therefore, it is referred to as an LC filter. Proper component selection of the LC filter is critical to meet the desired audio performance, efficiency, EMC/EMI requirements, and cost for the end application. This application report serves as a guide to aid in the selection of LC filter components for class-D amplifiers to meet target-design goals of the end system.

1.1 Class-D Output Configurations

Some TI class-D [audio amplifiers](#) support multiple output configurations in a single device. This allows for a high level of flexibility for the end application. Table 1 provides examples of TI class-D devices for [industrial](#) and [speaker](#) applications, illustrating the range of output configurations, power levels, and supply voltages that influence LC filter design.

Table 1-1. TI Class-D Audio Amplifier Examples

Specifications	TAS2120	TAS2320	TAS5830
Output Configuration	BTL (mono)	BTL (mono)	BTL (stereo) / PBTL (mono)
Output Power	1 x 8.4W	1 x 15W	2 x 60W
Peak Current	5.1A (Boost)	4.1A	8A
PVDD Range	2.5V-15V	2.5V-15V	4.5V-30V
Architecture	Open-loop, digital input	Open-loop, digital input	Closed-loop, digital input

1.1.1 Bridged-Tied Load (BTL)

Bridge-tied load (BTL) is the most common output configuration for a class-D amplifier. A BTL configuration consists of one amplifier driving one side of a load and another amplifier, with an inverted signal from the first amplifier, driving the other side of the load. This results in 2× more voltage swing across the load for a given supply voltage when compared to a single-ended configuration where one side of the load is tied to the amplifier output and the other side to ground. Twice the voltage swing across the load equates to a 4× power increase because $P = V^2 / R$. So, a BTL load configuration offers 4× more power to the load than a single-ended configuration from the same supply voltage.

Because each side of the load is driven, the load is not ground-referenced. Therefore, the voltage across the load must be measured differentially relative to ground. The [TAS5830](#) is an example of a TI device operating in a BTL output configuration.

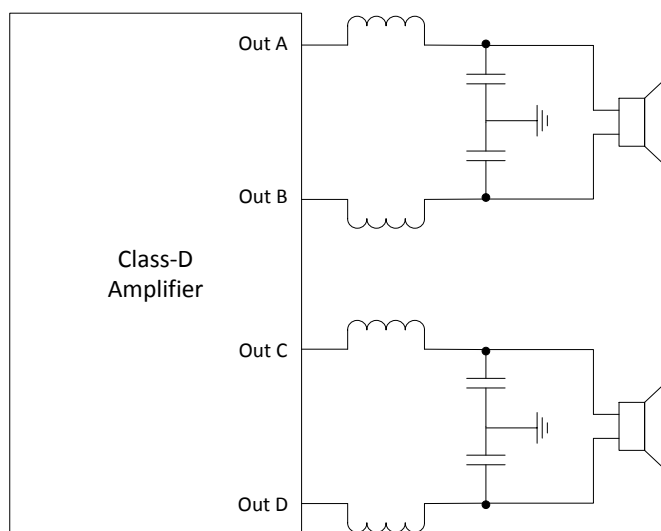

Figure 1-1. Stereo (Two-Channel) BTL Class-D Amplifier

1.1.2 Parallel Bridge-Tied Load (PBTL)

Parallel bridged-tied load (PBTL) is an output configuration that takes a stereo BTL amplifier and connects the outputs in parallel for a single mono channel. Although the maximum output voltage swing is the same for a BTL output configuration, the maximum current has been increased because each output shares the load current. This often allows for lower-impedance loads to be driven with higher output power when compared to BTL with the same supply voltage. The amplifier current limit has doubled compared to BTL. For example, the current limit on the [TAS5825](#) is 7.5A and the power output is 38W per channel and in PBTL mode the current limit is 15A and the power output is 65W.

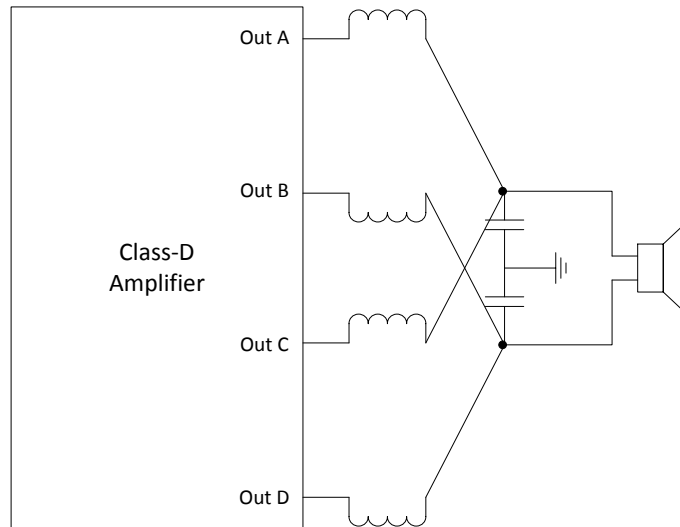

Figure 1-2. Mono PBTL Class-D Amplifier

1.1.3 Single-Ended (SE)

In a single-ended (SE) configuration, only one output is used to drive the load rather than a pair of outputs operating out of phase, as found in BTL and PBTL configurations. For this reason, only half of the Signal swing is available compared to BTL or a quarter of the total output power. However this configuration can allow for four channels with a single stereo BTL amplifier as shown in [Figure 1-3](#). Some amplifiers like the [TAS5827](#) also allow a combination of 1× BTL and 2× SE channels for support of 2.1 audio systems with a single device.

Due to the PWM modulation of a class-D amplifier, a DC voltage of $PVDD / 2$ or half of the supply voltage is present after the LC filter. In SE mode, because the speaker is now ground-referenced, either a DC blocking capacitor or some other means of referencing the speaker to $PVDD / 2$ is necessary so that no DC voltage appears across the speaker.

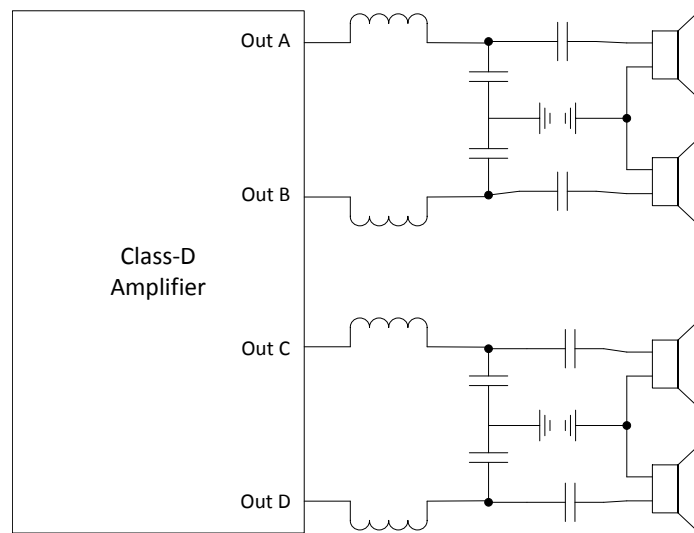

Figure 1-3. Four Single-Ended Outputs

1.2 Class-D Modulation Schemes

This section describes how analog signals are converted to PWM signals to drive the MOSFETs in the output bridge. Most class-D amplifiers can be classified as using one of two modulation techniques, AD (traditional) or BD modulation.

1.2.1 AD (Traditional) Modulation

The traditional switching technique (AD modulation) modulates the duty cycle of a rectangular waveform, such that its average content corresponds to the input analog signal. The BTL outputs (see [Figure 1-4](#)) are the inverse of each other. AD modulation has no significant common-mode switching content in its output. However, there is a common-mode DC voltage due to the average value of the PWM switching. Because both sides of the load see this DC voltage level, it does not contribute to power dissipation across the load. This DC voltage is equal to $PVDD / 2$, or half of the supply voltage. The TPA312xD2 family employs AD modulation.

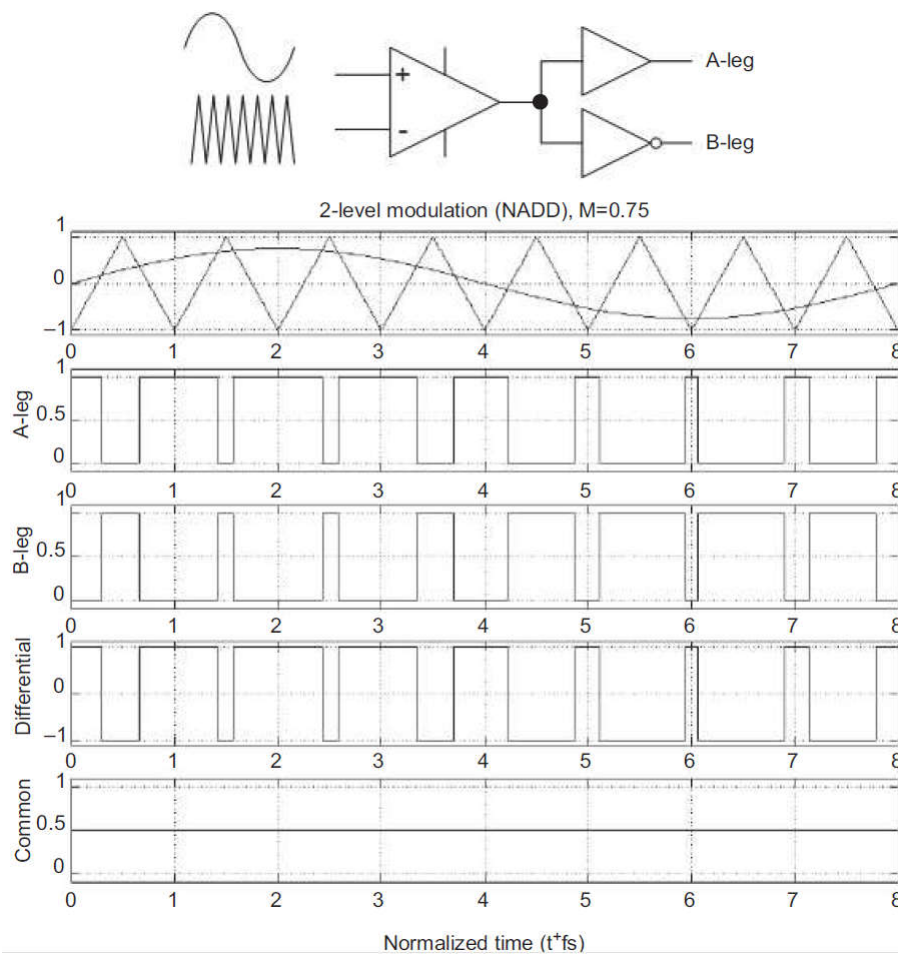

Figure 1-4. AD (Traditional) Modulation

Because the switching waveform is nearly entirely differential, a BTL-connected load across the A-leg and B-leg sees the full switching waveform. At idle, the amplifier switches at the nominal PWM frequency with a 50% duty cycle across the load. This causes significant current flow and power dissipation into the load. An LC filter is necessary to reduce the current to a small residual ripple for good efficiency.

Generally, the lower the ripple current for an AD modulation class-D amplifier, the better the efficiency due to reduced load dissipation and reduced I^2R loss across $R_{DS(on)}$ of the output FETs.

1.2.2 BD Modulation

The BD modulation switching technique modulates the duty cycle of the difference of the output signals such that its average content corresponds to the input analog signal. The BTL outputs (see [Figure 1-5](#)) are not the inverse of each other. BD modulation has significant common-mode content in its output. Some TAS modulators can be also be configured for BD modulation. Some of TI digital-input devices such as the [TAS2120](#), [TAS2320](#), and [TAS5830](#) use BD modulation by default.

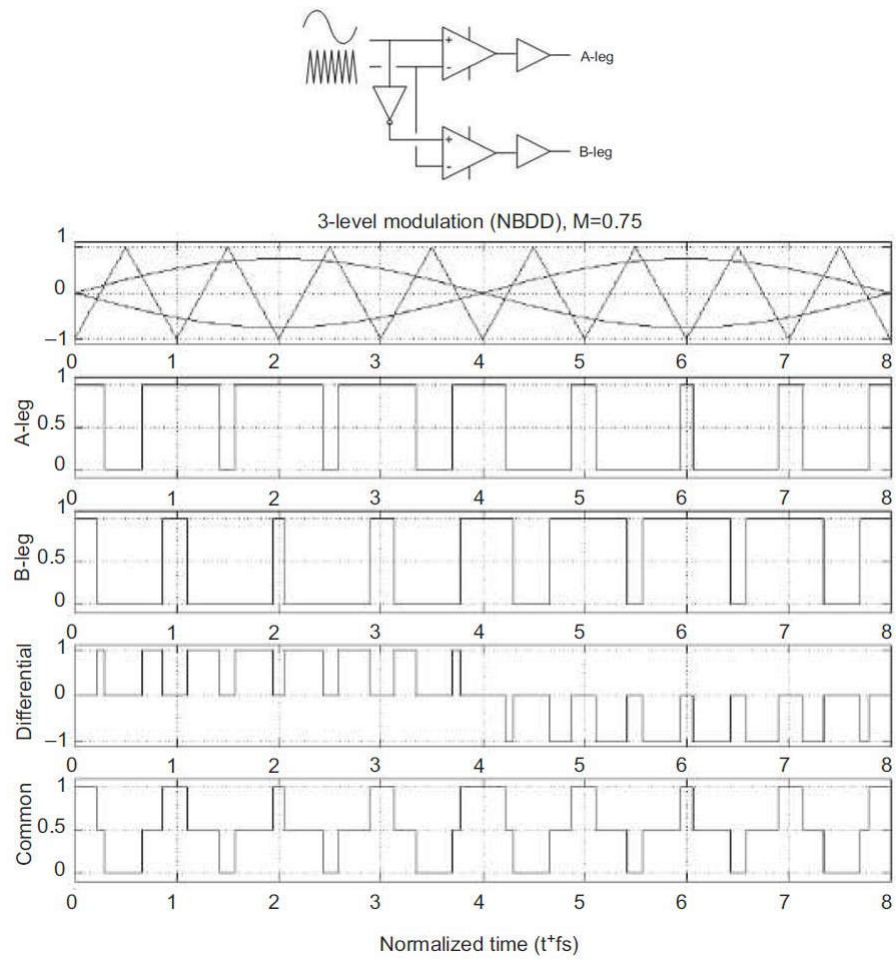

Figure 1-5. BD Modulation

1.3 Class-D Output LC Filter

1.3.1 Output LC Filter Frequency Response Properties

The frequency response of the second-order class-D LC output filter is critical when selecting the component values for the inductor and capacitor. The LC filter response also varies with speaker load impedance. The load impedance determines the damping ratio of the output LC filter and is classified as overdamped, critically damped, or underdamped. It is also important to understand the speaker load impedance variations for the application and select the L and C values that suit the expected load variations. Ideally, the LC filter value is selected for a critically damped, flat passband, and phase response. Two considerations when selecting components for the second-order low-pass filter is the cut-off frequency and Q factor or damping ratio.

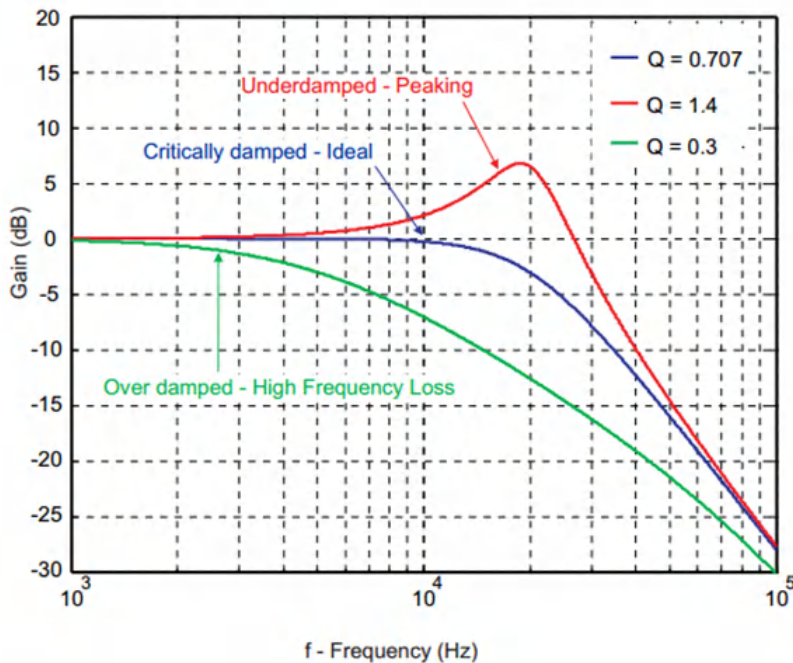

Figure 1-6. Effect of Q on Frequency Response

TI recommends using a second-order Butterworth low-pass filter because of its flat pass-band and phase response. TI does not recommend the use of LC filters that peak excessively, like the underdamped filter response shown in [Figure 1-6](#). At high frequency, the peaks are generally harsh to the human ear and can also trigger the protection circuitry, such as overcurrent, of some amplifiers. However, overdamped filters result in attenuation of high-frequency audio content in the audio band.

1.3.2 Class-D BTL Output LC Filter Topologies

For class-D amplifiers, there are primarily two filter types used depending on the modulation scheme. The Type-1 filter is a differential filter used for AD modulation amplifiers only. The Type-2 filter is a common-mode filter primarily used for BD modulation.

Table 1-2 shows each filter type and the associated single-ended equivalent that is used later in this section for frequency response and damping analysis. The single-ended equivalent is used to make the computations for each filter type easier.

Table 1-2. Class-D Filter Types and Their SE Equivalent Circuits

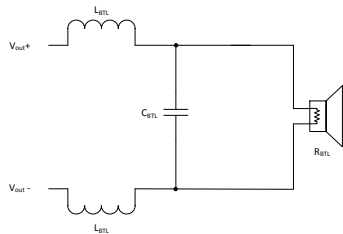
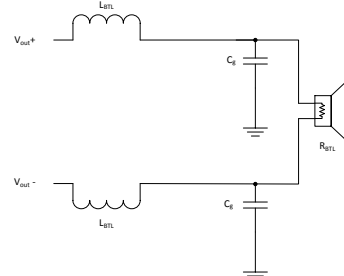
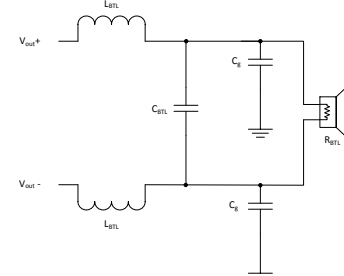
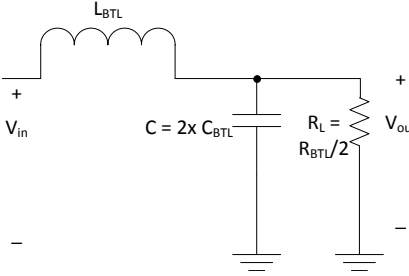
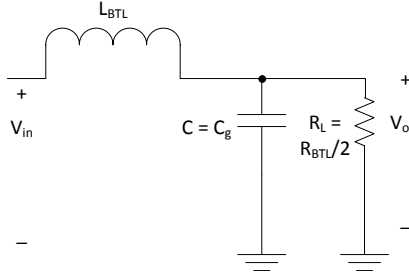
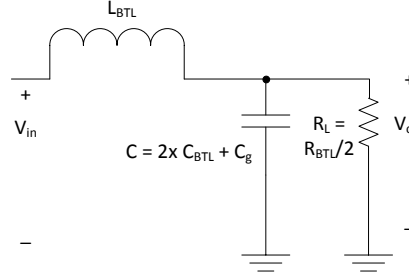
Class-D BTL Filter Types					
Type-1		Type-2		Hybrid	
					
Type-1 Single-Ended Equivalent		Type-2 Single-Ended Equivalent		Hybrid Single-Ended Equivalent	
					
Class-D Modulation:	AD	Class-D Modulation:	BD or AD (see Section 1.3.7)	Class-D Modulation:	AD
Filter Type:	Differential	Filter Type:	Common Mode	Filter Type:	Hybrid
C _{BTL} = Differential bridged tied load capacitor C _g = Single-ended capacitor to ground R _{BTL} = Differential load impedance L _{BTL} = Series inductor					

1.3.3 Single-Ended Filter Calculations

Since the goal is to use the single-ended equivalent of each filter type for easy analysis, the frequency response of the single-ended filter must be known.

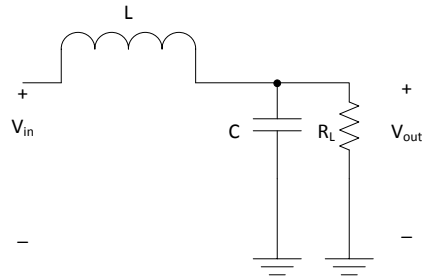

Figure 1-7. Single-Ended LC Filter

The equations for the single-ended LC filter shown in [Figure 1-7](#) follow:

$$f_0 = \frac{\omega_0}{2\pi} = \frac{1}{2\pi \sqrt{L \times C}} \quad \text{Cutoff frequency of single – ended LC filter} \quad (1)$$

$$\omega_0 = 2\pi f_0 \quad \text{Conversion between radians and frequency in hertz} \quad (2)$$

$$Q = R_L \sqrt{\frac{C}{L}} \quad \text{Quality Factor Q} \quad (3)$$

$$\zeta = \frac{1}{2Q} = \frac{1}{2 \times R_L \sqrt{\frac{C}{L}}} \quad \text{Damping Ratio} \quad (4)$$

As previously mentioned, it is usually desirable to design a filter that is critically damped with a Butterworth response. For this type of filter, $Q = 0.707 = 1 / \sqrt{2}$. By substituting $Q = 1 / \sqrt{2}$ into equations for *Cut-off Frequency* and *Quality Factor* previously listed, L and C values can be derived for a critically damped system assuming the desired cut-off frequency, ω_0 , is known.

$$L = \frac{R_L \times \sqrt{2}}{\omega_0} \quad \text{Inductor value for critically damped Butterworth filter} \quad (5)$$

$$C = \frac{1}{\omega_0 \times R_L \times \sqrt{2}} \quad \text{Capacitor value for critically damped Butterworth filter} \quad (6)$$

1.3.4 Type-1 Filter Analysis

The Type-1 filter is a differential filter designed for AD modulation class-D amplifiers. AD modulation has no significant common-mode content on its outputs, thus only the differential mode is needed for analysis. The differential BTL components, C_{BTL} and R_{BTL} of the AD modulation LC filter shown in Figure 1-8, can be simplified to a single-ended equivalent.

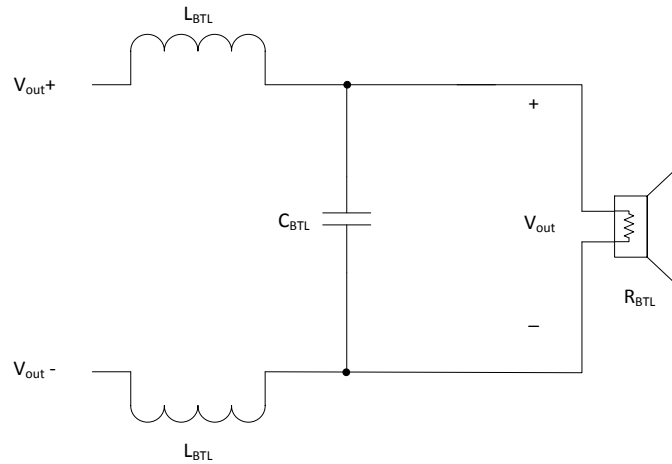

Figure 1-8. Type-1 Filter for AD Modulation

From inspection, the Type-1 filter can be split into an equivalent common-mode filter as shown in Figure 1-9. C_{BTL} must be scaled by a factor of 2 since in the common-mode model, the capacitors appear in series.

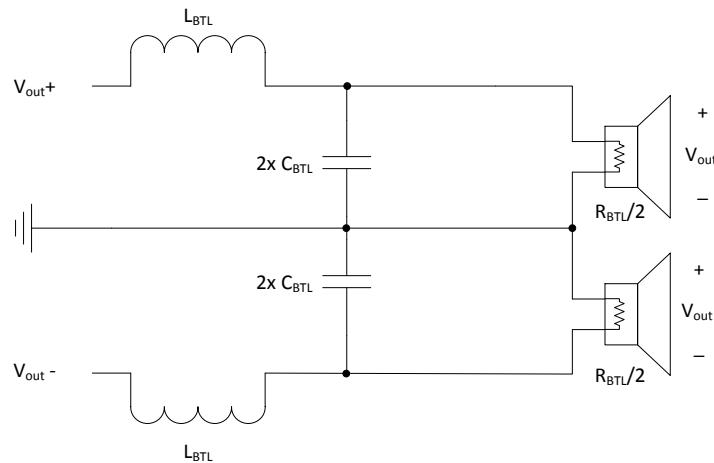

Figure 1-9. Type-1 Filter Equivalent Circuit

Now the single-ended equivalent can be drawn as shown in Figure 1-10. The difference between the original filter and single-ended equivalent is that C_{BTL} has been multiplied by a factor of two and R_{BTL} has been divided by a factor of two.

When using the single-ended equivalent circuit to find the filter component values, $C_{BTL} = C / 2$.

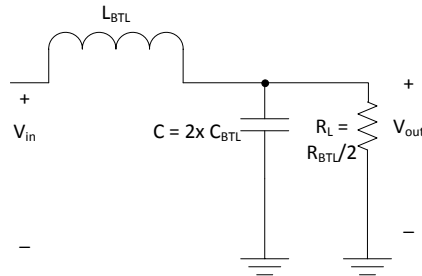

Figure 1-10. Type-1 Single-Ended Equivalent Circuit

1.3.4.1 Type-1 Frequency Response Example

Using the equations outlined in Section 1.3.3, a filter is designed with a targeted 40-kHz bandwidth and 4-Ω speaker load.

The L and C values can be calculated as follows:

$$L = \frac{R_L \times \sqrt{2}}{\omega_0} \text{ where } R_L = \frac{R_{BTL}}{2}, R_{BTL} = 4 \Omega, \omega_0 = 2\pi f_0, \text{ and } f_0 = 40 \text{ kHz}$$

$$L = \frac{R_{BTL}/2 \times \sqrt{2}}{2\pi f_0} = \frac{2\sqrt{2}}{2\pi \times 40000} = 11.25 \mu\text{H}$$

The nearest standard inductor value is 10 μH.

$$L_{BTL} = L = 10 \mu\text{H}$$

$$C = \frac{1}{\omega_0 \times R_L \times \sqrt{2}} \text{ where } R_L = \frac{R_{BTL}}{2}, R_{BTL} = 4 \Omega, \omega_0 = 2\pi f_0, \text{ and } f_0 = 40 \text{ kHz}$$

$$C = \frac{1}{\omega_0 \times R_L \times \sqrt{2}} = \frac{1}{2\pi f_0 \times R_{BTL}/2 \times \sqrt{2}} = \frac{1}{2\pi \times 40000 \times 2\sqrt{2}} = 1.4 \mu\text{F}$$

$$C_{BTL} = \frac{C}{2} = 0.70 \mu\text{F} \approx 0.68 \mu\text{F}$$

The standard capacitor value is 0.68 μF.

Using the standard inductor and capacitor values from the previous calculations, the Q factor for 4 Ω is:

$$Q = R_L \sqrt{\frac{C}{L}} = \frac{R_{BTL}}{2} \sqrt{\frac{2 \times C_{BTL}}{L_{BTL}}} = 2 \sqrt{\frac{1.36 \times 10^{-6}}{10 \times 10^{-6}}} = 0.737 \quad (7)$$

With the targeted Q of $1 / \sqrt{2} \approx 0.707$ and the cut-off frequency is:

$$f_0 = \frac{1}{2\pi\sqrt{L \times C}} = \frac{1}{2\pi\sqrt{L_{BTL} \times 2 \times C_{BTL}}} = \frac{1}{2\pi\sqrt{(10 \times 10^{-6}) \times (1.36 \times 10^{-6})}} = 43156 \text{ Hz}$$

The peaking at cut-off frequency in dB is:

$$\text{Peaking}(\omega_0) = 20\log_{10} Q = -2.65 \text{ dB}$$

Using the transfer function (Equation 8), the frequency response of the selected LC filter can be plotted for different speaker loads to provide a complete visual evaluation of the LC filter response with various speaker loads.

$$H_{\text{Diff}}(s) = \frac{V_{\text{OUT}}(s)}{V_{\text{IN}}(s)} = \frac{1}{1 + s \times \frac{L_{\text{BTL}}}{R_{\text{BTL}}/2} \times 2 \times C_{\text{BTL}} + s^2} \quad (8)$$

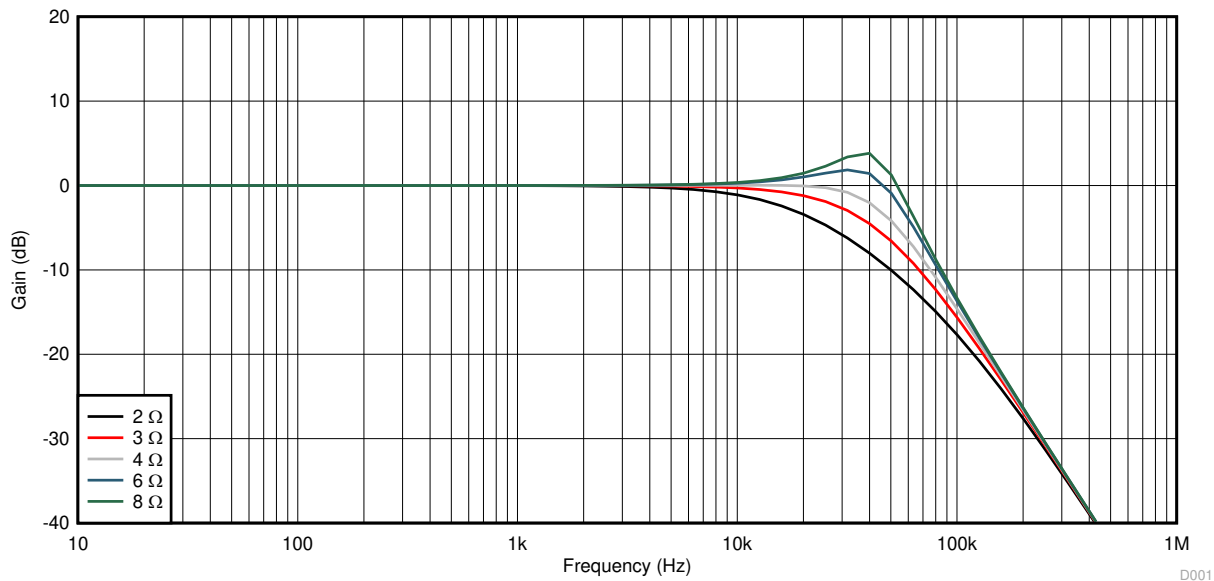

Figure 1-11. Type-1 LC Filter Response With $C_{\text{BTL}} = 0.68 \mu\text{F}$ and $L_{\text{BTL}} = 10 \mu\text{H}$

1.3.5 Type-2 Filter Analysis

The Type-2 class-D filter is a common-mode filter designed for BD or AD modulation amplifiers. Since the Type-2 filter is common mode, it can be easily converted into its equivalent single-ended form. The common-mode BTL components C_g and differential load R_{BTL} of the LC filter shown in Figure 1-12, can be simplified to a single-ended equivalent.

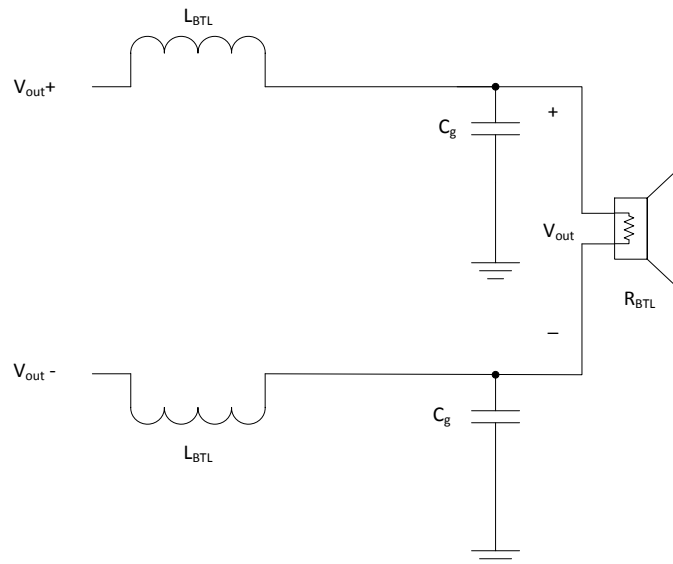

Figure 1-12. Type-2 Filter for BD or AD Modulation

From inspection, the Type-2 filter can be split into an equivalent common-mode filter as shown in Figure 1-13.

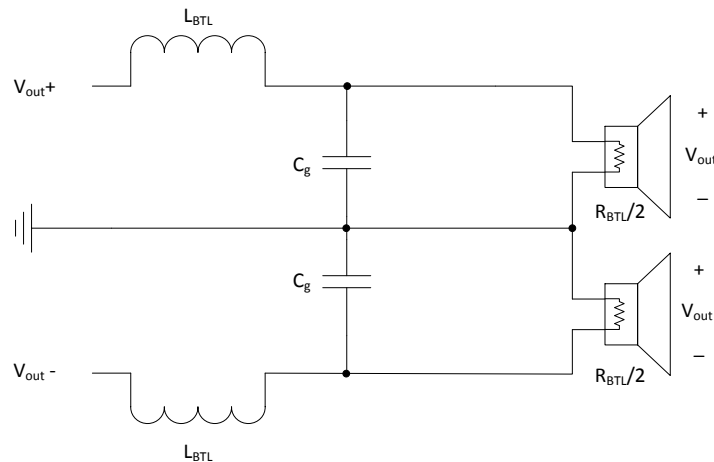

Figure 1-13. Type-2 Filter Equivalent Circuit

Now the single-ended equivalent can be drawn. The only difference for single-ended analysis is that R_{BTL} has been divided by a factor of two.

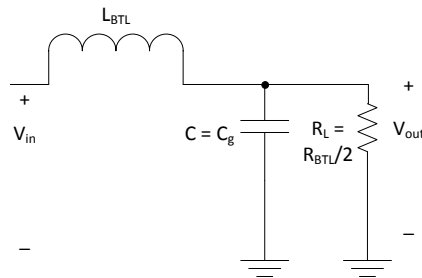

Figure 1-14. Type-2 Filter Single-Ended Equivalent Circuit

1.3.5.1 Type-2 Frequency Response Example

Using the equations outlined in Section 1.3.3, a filter is designed with a targeted 40-kHz bandwidth and 4- Ω speaker load.

$$L = \frac{R_L \times \sqrt{2}}{\omega_0} \text{ where } R_L = \frac{R_{BTL}}{2}, R_{BTL} = 4 \Omega, \omega_0 = 2\pi f_0, \text{ and } f_0 = 40 \text{ kHz}$$

$$L = \frac{R_{BTL}/2 \times \sqrt{2}}{2\pi f_0} = \frac{2\sqrt{2}}{2\pi \times 40000} = 11.25 \mu\text{H}$$

The nearest standard inductor value is 10 μH .

$$L_{BTL} = L = 10 \mu\text{H}$$

$$C = \frac{1}{\omega_0 \times R_L \times \sqrt{2}} \text{ where } R_L = \frac{R_{BTL}}{2}, R_{BTL} = 4 \Omega, \omega_0 = 2\pi f_0, \text{ and } f_0 = 40 \text{ kHz}$$

$$C = \frac{1}{\omega_0 \times R_L \times \sqrt{2}} = \frac{1}{2\pi f_0 \times R_{BTL}/2 \times \sqrt{2}} = \frac{1}{2\pi \times 40000 \times 2\sqrt{2}} = 1.4 \mu\text{F}$$

$$C_g = C = 1.4 \mu\text{F} \approx 1.5 \mu\text{F}$$

The standard capacitor value is 1.5 μF .

Using the standard inductor and capacitor values from the previous calculations, the Q factor for 4 Ω is:

$$Q = R_L \sqrt{\frac{C}{L}} = \frac{R_{BTL}}{2} \sqrt{\frac{C_g}{L_{BTL}}} = 2 \sqrt{\frac{1.5 \times 10^{-6}}{10 \times 10^{-6}}} = 0.775$$

With the targeted Q of $1/\sqrt{2} \approx 0.707$ and the cut-off frequency is:

$$f_0 = \frac{1}{2\pi\sqrt{L \times C}} = \frac{1}{2\pi\sqrt{L_{BTL} \times C_g}} = \frac{1}{2\pi\sqrt{(10 \times 10^{-6}) \times (1.5 \times 10^{-6})}} = 41093 \text{ Hz}$$

The peaking at the cut-off frequency in dB is:

$$\text{Peaking}(\omega_0) = 20\log_{10} Q = -2.22 \text{ dB}$$

Using the transfer function below the frequency response of the selected LC filter can be plotted for different speaker loads to provide a complete visual evaluation of the LC filter response with various speaker loads.

$$H_{\text{Diff}}(s) = \frac{V_{\text{OUT}}(s)}{V_{\text{IN}}(s)} = \frac{1}{1 + s \times \frac{L_{BTL}}{R_{BTL}/2} + L_{BTL} \times C_g + s^2} \quad (9)$$

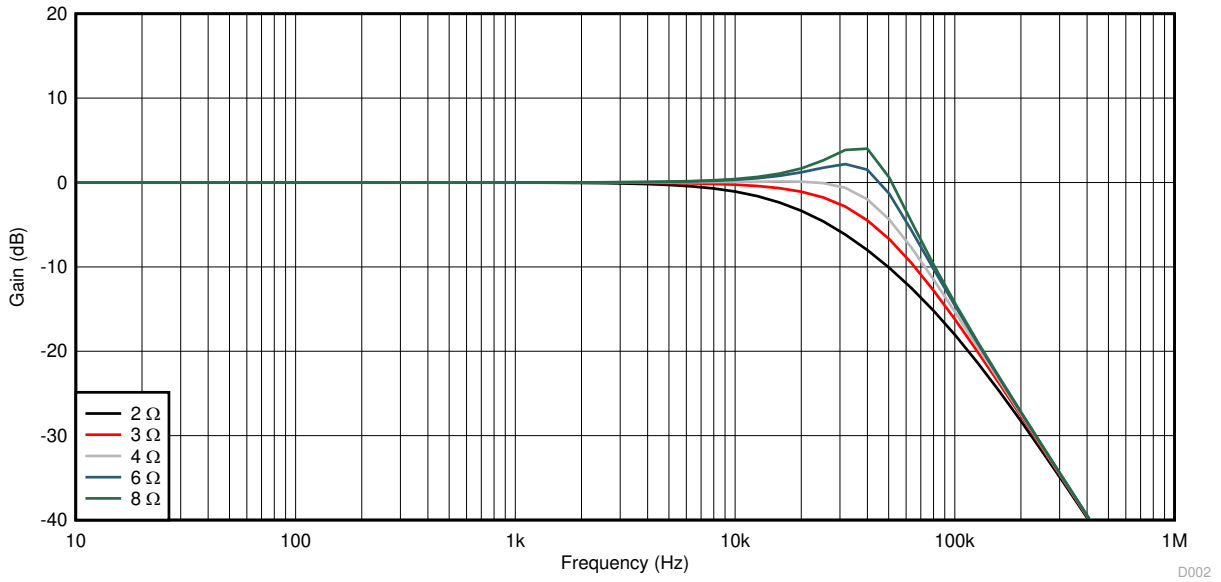

Figure 1-15. Type-2 LC Filter Response With $C_g = 1.5 \mu\text{F}$ and $L_{BTL} = 10 \mu\text{H}$

1.3.6 Hybrid Filter for AD Modulation

For some applications, it may be beneficial to use a hybrid filter combining the Type-1 and Type-2 filters for an AD modulation amplifier. By adding C_g to the Type-1 filter, the high-frequency decoupling to ground is improved, since the amplifier AD PWM modulation is never perfectly differential. For this configuration, TI recommends $C_g = 0.1 \times C_{BTL}$.

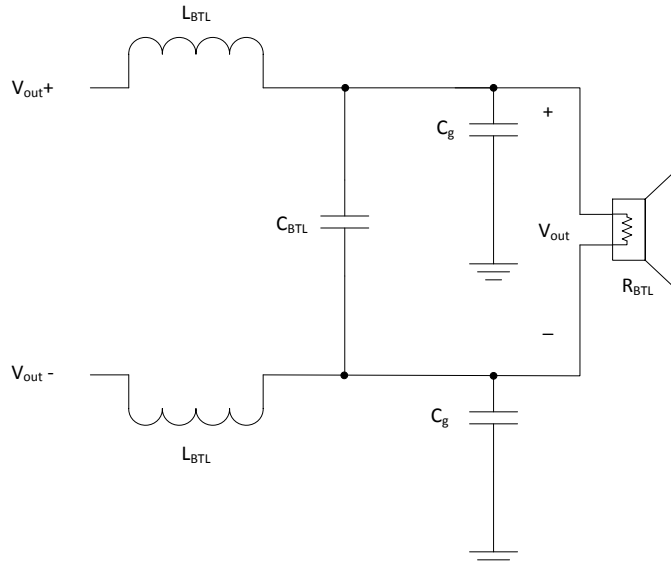

Figure 1-16. Hybrid Filter for AD Modulation

From the previous study of the Type-1 and Type-2 filters, the Hybrid Filter single-ended equivalent can be easily drawn.

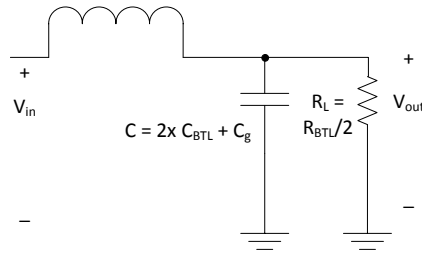

Figure 1-17. Hybrid Filter Single-Ended Equivalent Circuit

1.3.6.1 Hybrid Filter Frequency Response Example

Using the equations outlined in [Section 1.3.3](#), a filter is designed with a targeted 40-kHz bandwidth and 4-Ω speaker load.

$$L = \frac{R_L \times \sqrt{2}}{\omega_0} \text{ where } R_L = \frac{R_{BTL}}{2}, R_{BTL} = 4 \Omega, \omega_0 = 2\pi f_0, \text{ and } f_0 = 40 \text{ kHz}$$

$$L = \frac{R_{BTL}/2 \times \sqrt{2}}{2\pi f_0} = \frac{2\sqrt{2}}{2\pi \times 40000} = 11.25 \mu\text{H}$$

The nearest standard inductor value is 10 μH.

$$L_{BTL} = L = 10 \mu\text{H}$$

$$C = \frac{1}{\omega_0 \times R_L \times \sqrt{2}} \text{ where } R_L = \frac{R_{BTL}}{2}, R_{BTL} = 4 \Omega, \omega_0 = 2\pi f_0, \text{ and } f_0 = 40 \text{ kHz}$$

$$C = \frac{1}{\omega_0 \times R_L \times \sqrt{2}} = \frac{1}{2\pi f_0 \times R_{BTL}/2 \times \sqrt{2}} = \frac{1}{2\pi \times 40000 \times 2\sqrt{2}} = 1.4 \mu\text{F}$$

$$C = 2 \times C_{BTL} + C_g \text{ where } C_g \approx \frac{2 \times C_{BTL}}{10}$$

$$C = 2 \times C_{BTL} + \frac{2 \times C_{BTL}}{10} = 1.4 \mu\text{F}$$

$$C_{BTL} = \frac{C}{2.2} = 0.63 \mu\text{F} \text{ and } C_g = \frac{2 \times C_{BTL}}{10} = 0.12 \mu\text{F}$$

The standard capacitor values are 0.63 μF and 0.12 μF.

Using the standard inductor and capacitor values from the previous calculations, the Q factor for 4 Ω is:

$$Q = R_L \sqrt{\frac{C}{L}} = \frac{R_{BTL}}{2} \sqrt{\frac{2.2 \times C_{BTL}}{L_{BTL}}} = 2 \sqrt{\frac{1.38 \times 10^{-6}}{10 \times 10^{-6}}} = 0.743$$

With the targeted Q of $1/\sqrt{2} \approx 0.707$ and the cut-off frequency is:

$$f_0 = \frac{1}{2\pi\sqrt{L \times C}} = \frac{1}{2\pi\sqrt{L_{BTL} \times 2.2 \times C_{BTL}}} = \frac{1}{2\pi\sqrt{(10 \times 10^{-6}) \times (1.38 \times 10^{-6})}} = 42843 \text{ Hz}$$

The peaking at the cut-off frequency in dB is:

$$\text{Peaking}(\omega_0) = 20 \log_{10} Q = -2.58 \text{ dB}$$

Using the transfer function below the frequency response of the selected LC filter can be plotted for different speaker loads to provide a complete visual evaluation of the LC filter response with various speaker loads.

$$H_{\text{Diff}}(s) = \frac{V_{\text{OUT}}(s)}{V_{\text{IN}}(s)} = \frac{1}{1 + s \times \frac{L_{\text{BTL}}}{R_{\text{BTL}}/2} + L_{\text{BTL}} \times 2 \times C_{\text{BTL}} + C_g + s^2} \quad (10)$$

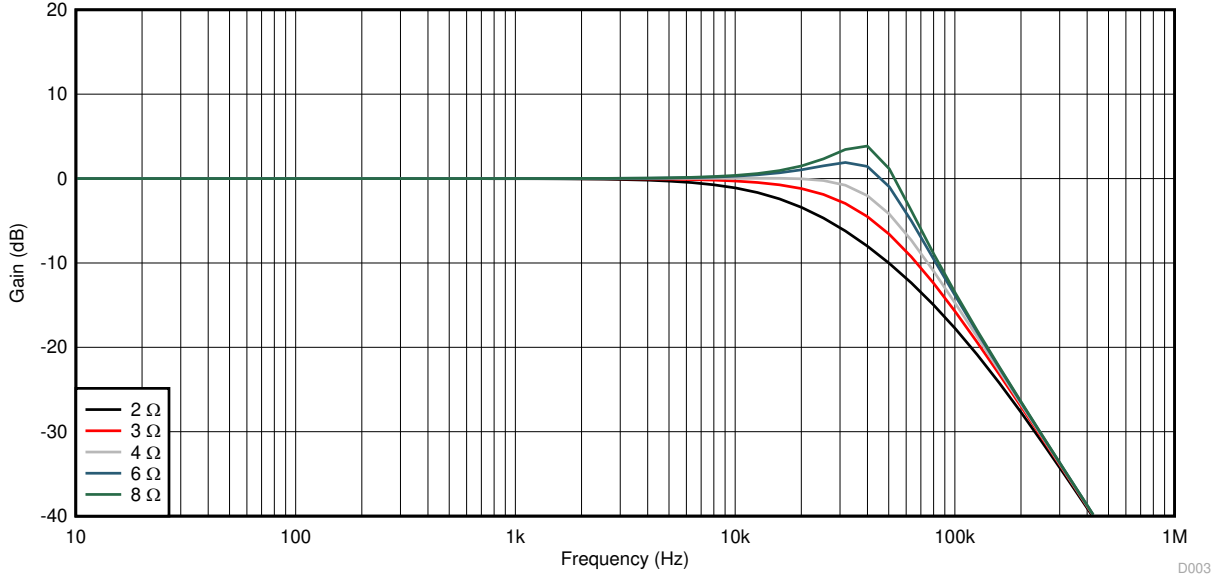

Figure 1-18. Hybrid LC Filter Response With $C_{\text{BTL}} = 0.63 \mu\text{F}$, $C_g = 0.12 \mu\text{F}$, and $L_{\text{BTL}} = 10 \mu\text{H}$

1.3.7 AD Modulation With Type-1 or Type-2 Filters

Since the C_g capacitors on the Type-2 filter share a common node through ground, differential signals will see a capacitance value of $C_g / 2$ since the capacitors appear in series for differential signals only. Therefore, with proper selection of the C_g capacitance value, the Type-2 can also be used for AD modulation class-D amplifiers which require a differential filter. Conversion from Type-1 to Type-2 only requires scaling of C_{BTL} by a factor of 2. That is, $C_g = 2 \times C_{\text{BTL}}$ for identical filter cut-off frequency and damping factor.

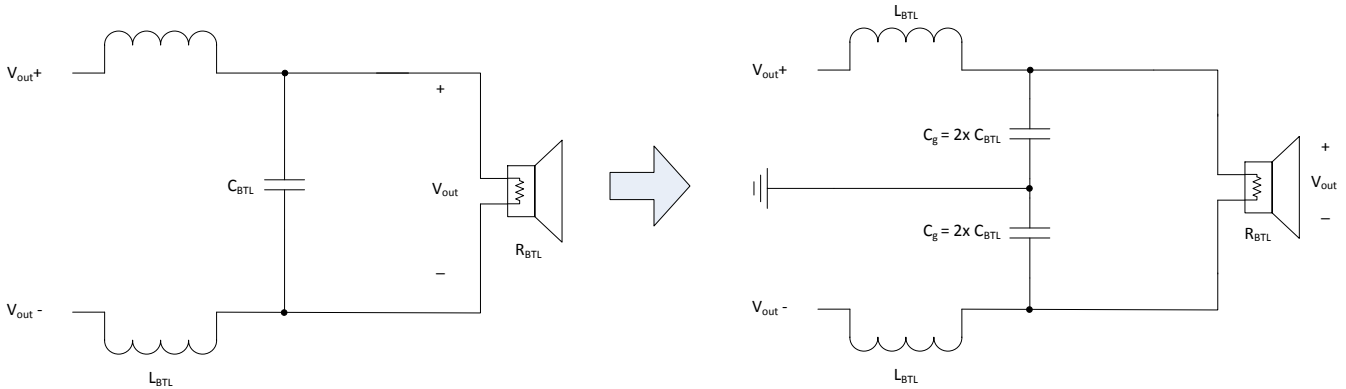

Figure 1-19. Type-1 AD Modulation Filter Converted to Type-2

1.3.8 LC Filter Quick Selection Guide

The filter components in the following tables are based on a Type-2 filter configuration previously shown. The table parameters are indicators of the LC filter response when selecting the inductor and capacitor values. The Q gives insight into the damping of the filter and whether there is peaking at high frequency. The f_0 is the resonant cut-off frequency of the filter and provides insight on the bandwidth of the filter. The peaking at 20-kHz is an

indicator of the flatness of the filter in the audio band. Based on the PWM frequency of the class-D amplifier it is a good practice to access the amount of the carrier fundamental frequency the filter attenuates. Higher attenuation helps minimize the risk of carrier signal interference.

Table 1-3. Filter Components – $R_{BTL} = 8 \Omega$

Q	f_0 (kHz)	Peaking @ 20-kHz (dB)	L_{BTL} (μ H)	C_g (μ F)	Attenuation @ 400-kHz (dB)	Attenuation @ 600-kHz (dB)
0.708	60	-0.051	15	0.47	-33	-41
0.196	73	0.927	10	0.47	-29	-37

Table 1-4. Filter Components – $R_{BTL} = 6 \Omega$

Q	f_0 (kHz)	Peaking @ 20-kHz (dB)	L_{BTL} (μ H)	C_g (μ F)	Attenuation @ 400-kHz (dB)	Attenuation @ 600-kHz (dB)
0.639	49	-0.408	15	0.68	-36	-44
0.639	61	0.122	10	0.68	-33	-40
0.777	88	0.067	7	0.47	-26	-34

Table 1-5. Filter Components – $R_{BTL} = 4 \Omega$

Q	f_0 (kHz)	Peaking @ 20-kHz (dB)	L_{BTL} (μ H)	C_g (μ F)	Attenuation @ 400-kHz (dB)	Attenuation @ 600-kHz (dB)
0.791	50	-0.429	10	1.0	-36	-44
0.756	60	0.067	7	1.0	-33	-40

1.4 Inductor Selection for High-Performance Class-D Audio

1.4.1 Inductor Linearity

The inductance versus current profile for the inductor used in the output LC filter of a class-D amplifier can significantly impact the total harmonic distortion (THD) performance.

An ideal inductor maintains the specified inductance value no matter what current passes through it. However, real-world inductors always have decreasing inductance with increasing current. At some point, the current level saturates the inductor and the inductance falls off severely. This is often specified as I_{sat} . Because inductor linearity is a function of current, inductor distortion is higher with lower-impedance loads.

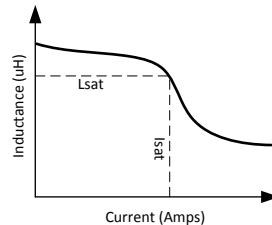

Figure 1-20. Typical Inductor Saturation Curve

Keep in mind that the inductance change at the I_{sat} current rating varies between manufacturers and even inductor types. Some manufacturers specify I_{sat} at a 30% or higher change in inductance. Use of this inductor all the way to the I_{sat} rating for an LC class-D filter results in very poor audio performance.

To illustrate the impact of inductor linearity, different inductors were tested with the ultra-low distortion TPA3251 amplifier. Table 1-6 shows data collected from four different inductors that have good linearity specifications for high-performance class-D audio amplifiers.

The inductance was measured at 1 A of current and again at 20 A of current with a 600-kHz test signal, which is the nominal PWM switching frequency of the TPA3251 amplifier. The average change of inductance was calculated for 10 samples of each inductor.

Table 1-6. Average Change in Inductance for 10 Inductor Samples

Manufacturer	Part Number	Nominal Inductance	Average Inductance Change (1 A–20 A)
Würth	7443630700	7 µH	0.94%
Würth	74436301000	10 µH	1.38%
Coilcraft	MA5173-AE	7 µH	1.16%
Coilcraft	MA5172-AE	10 µH	1.55%

From the foregoing data, the 10-µH inductor from Würth is more linear than the 10-µH inductor from Coilcraft. It is also important to note that the 7-µH and 10-µH inductors from Würth are wound on the same core. Likewise, the 7-µH and 10-µH from Coilcraft are also wound on the same core. Generally, the higher the inductance (the more turns of wire) for a given core material, size, and geometry, the less linear the inductor.

The inductors tested in Table 1-6 were then populated onto the TPA3251 EVM and tested for total harmonic distortion plus noise (THD+N) performance.

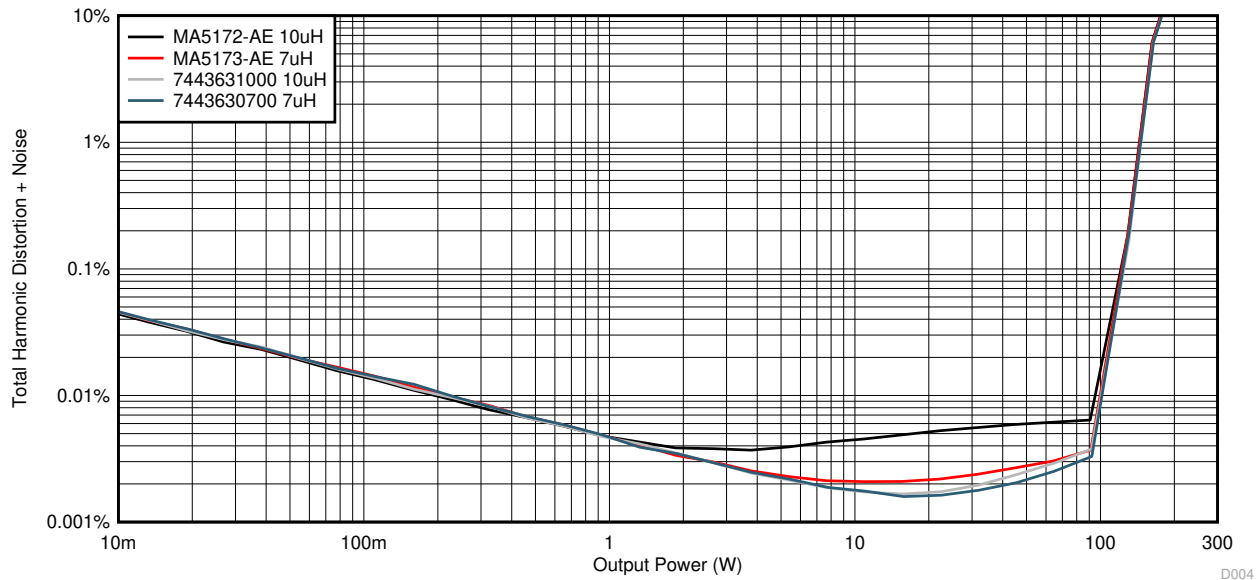

Figure 1-21. TPA3251EVM THD+N vs Output Power, 4 Ω

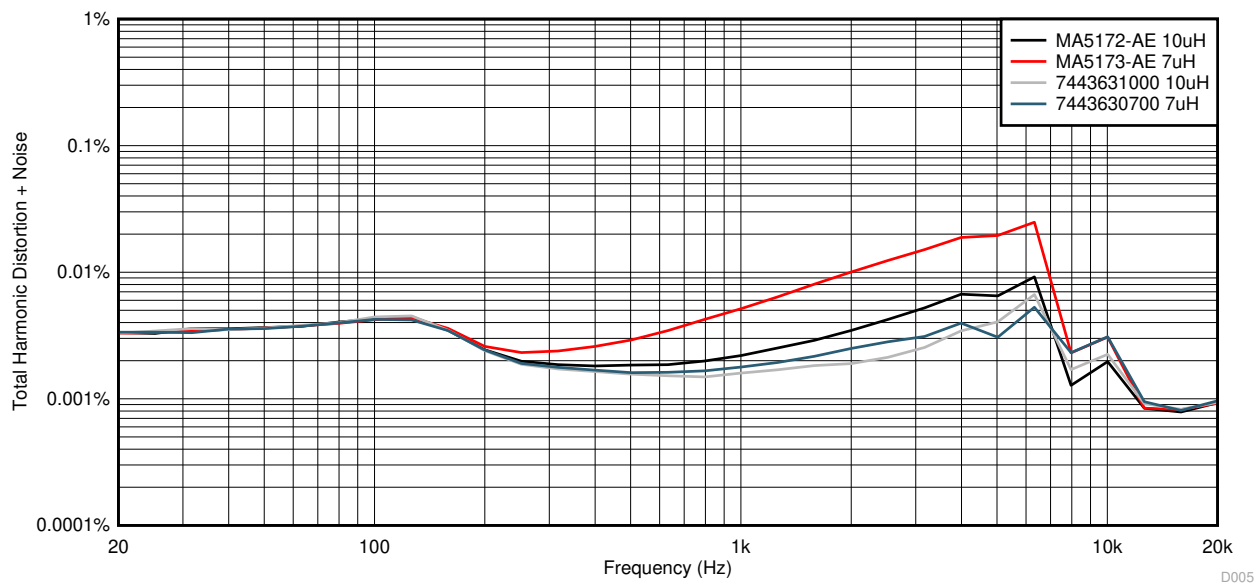

Figure 1-22. TPA3251EVM THD+N vs Signal Frequency, 20 W, 4 Ω

In [Figure 1-21](#), the more-linear inductors show improved mid-power THD+N performance. With the Würth inductors, both the 10- μ H and 7- μ H offer very high performance and nearly approach the characteristic curve of an ideal amplifier. The distortion performance is noise-limited nearly all the way to clipping as shown by the continuously decreasing slope of the THD+N plot. With a more-linear inductor, we are able to see deeper into the noise floor of the amplifier before the harmonic content of the output signal begins to dominate the noise.

From [Figure 1-22](#), the THD+N versus frequency performance also improves significantly in the 1-kHz to 6-kHz range. This is considered to be the most sensitive frequency region of the human ear since it is right in the middle of our audible bandwidth.

If the LC filter design is based on an amplifier where higher THD performance is acceptable, or if the native THD of the amplifier was higher, the 10- μ H from Coilcraft™ may be a suitable candidate. In the end, the designer of the system must make a choice between inductor linearity, cost, and size.

1.4.2 Ripple Current

Ripple current is defined as the alternating current flowing through the output inductor of a class-D amplifier. Due to the out-of-phase nature of a BTL or PBTL amplifier operating in AD modulation, if no LC filter was present, the load sees the full PWM signal across its terminals. This causes a high-frequency current to pass through the load, which leads to high power dissipation, poor efficiency, and potential speaker damage.

With an LC filter, specifically as the cut-off frequency of the LC filter is reduced relative to the PWM switching frequency of the amplifier, the ripple current is reduced such that only a small residual ripple voltage is present after the LC filter. The reactance of the LC filter removes the rest of the ripple and ideally does not dissipate any power. Speaker voice coil inductance can further reduce the ripple current.

Lower ripple current is also desired in both BD- and AD-modulation amplifiers to reduce loss across the $R_{DS(on)}$ of the output FETs and the DCR of the output inductors. In a BTL configuration, the total power dissipation due to the ripple current must be considered for both sides of the output bridge.

The ripple current through an inductor is defined as:

$$di / dt = v / L \tag{11}$$

where

- di / dt = rate of change in inductor current
- v = voltage across the inductor
- L = inductance

1.4.2.1 Calculating Ripple Current for a Single-Supply Class-D Amplifier

At idle, the PWM duty cycle of a class-D amplifier is 50%. Calculating the maximum ripple current of the amplifier at idle is now possible.

AD- and BD-modulation class-D amplifiers produce a common-mode voltage of $PVDD / 2$ after the LC filter at idle, because this is the average value of the 50% duty cycle PWM switching waveform (see [Figure 1-23](#) and [Figure 1-24](#)).

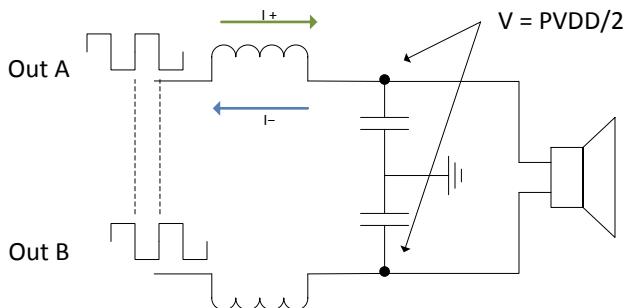
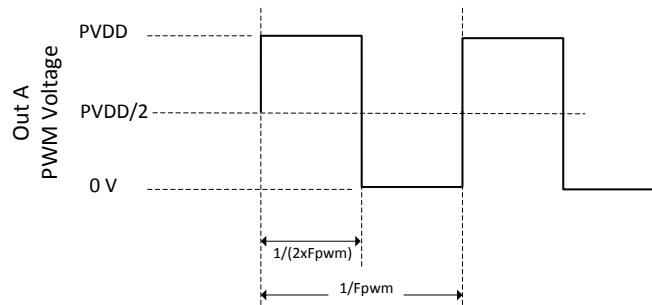
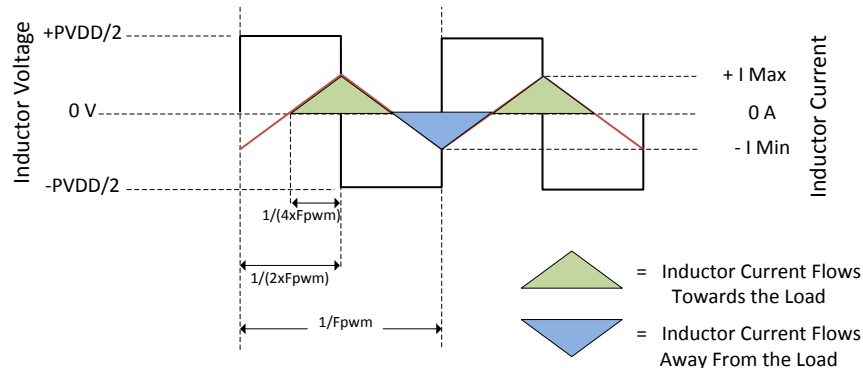

Figure 1-23. PVDD / 2 Common-Mode Voltage

Therefore, the voltage across the output inductor actually changes polarity when the PWM voltage reaches $PVDD / 2$. The maximum voltage across the inductor is $PVDD / 2$ and the minimum voltage is $-PVDD / 2$ (see [Figure 1-25](#)).

Figure 1-24. PWM Voltage Waveform

From these arguments, the inductor voltage and current waveforms are drawn.

Figure 1-25. Inductor Voltage and Current

At idle, the positive and negative current flow through the inductor must be symmetrical and therefore centered around zero. Otherwise, there is a DC offset across the speaker and a constant average current flow through the load. The shaded regions in [Figure 1-25](#) indicate the direction of current flow.

Using [Figure 1-25](#) and [Equation 12](#), the peak ripple current at idle can be calculated.

$$\begin{aligned}
 I_{\text{Ripple,Peak}} &= \frac{PVDD / 2}{L} \delta t \\
 I_{\text{Ripple,Peak}} &= \frac{PVDD}{2 \times L} \times \frac{1}{4 \times f_{\text{PWM}}} \\
 I_{\text{Ripple,Peak}} &= \frac{PVDD}{8 \times L \times f_{\text{PWM}}} \tag{12}
 \end{aligned}$$

Increasing the inductance reduces the output ripple current, and better efficiency is generally observed.

1.4.3 Minimum Inductance

Some amplifiers require minimum inductance on the output. This specification is important to keep the amplifier reliable during an overcurrent (OC) event.

If the output of a BTL amplifier is accidentally shorted to ground without an inductor, the output current immediately increases up to a very high level as the PWM output signal transitions from low to high. Due to the time delay for typical OC protection to respond, the output current during this event can exceed the allowable limit and failure of the output stage is possible.

With an inductor, the rate of change in output current during a shorted output event is limited by the inductance. Therefore, the OC protection circuitry can respond before the current exceeds damaging levels.

Example

Assume there is an output short to ground on the TPA3251 device. During this event, the load side of the LC filter is at ground potential, not PVDD / 2 as normal. Therefore, the voltage across the inductor is the full PVDD supply voltage when the PWM output of the amplifier transitions high.

From the [TPA3251 175-W Stereo, 350-W MONO PurePath™ HD Analog-Input Power Stage Datasheet](#), the specified minimum inductance is 5 µH. The response time of the OC current protection is 150 ns. With a nominal supply voltage of 36 V, then the maximum rise in current before the OC protection is enabled can be calculated.

$$di = \frac{PVDD}{L} \times \text{OC Response Time}$$

$$1.08 \text{ A} = \frac{36 \text{ V}}{5 \times 10^{-6}} \times 150 \times 10^{-9} \tag{13}$$

Due to the 5-µH inductance on the output, the maximum rise in current is 1.08 A.

By bounding the rise in current, the amplifier is protected from severe current during an output short event.

1.4.4 Core Loss

Core loss is parasitic power dissipation in the core of an inductor. Also referred to as magnetic loss, core loss consumes amplifier power, generates additional heat, and spoils efficiency. Ideally, an inductor stores all of the energy in the core material used; however, there is always some power loss due to induced eddy currents in the core. Core loss varies with switching frequency, core material, and switching current.

Figure 1-26 shows the equivalent model of inductor core loss.

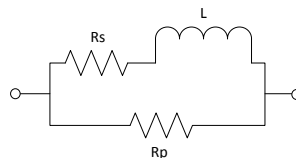

Figure 1-26. Inductor Core-Loss Model

R_s is a series resistance which is equal to the DC resistance (DCR) of the inductor (this resistance is due to the many turns of wire), L is the nominal inductance value, and R_p is a parallel resistance which models the core or magnetic losses.

From the foregoing model, it should be evident that if R_p is larger for a given voltage across the inductor, the power dissipation in resistor R_p is lower. Although there are many sources for calculations and theory on core loss, different inductors can be compared by using a quality LCR meter that can measure R_p to estimate the core loss.

Because core loss is a function of the operating parameters, it is important to set up the LCR to simulate conditions in the amplifier. For example, the test signal frequency should be set to the PWM frequency of the amplifier, and a bias current equal to the peak ripple current at idle should be forced. Under these conditions, comparative measurements of R_p can be taken.

Example

Ten inductors were measured on an Agilent E4980A LCR meter. The LCR meter tested the inductors with a 600-kHz, 2-V test signal and 1 A of DC current. R_p and the dissipation factor was measured. The inductors were then installed in the TPA3251EVM and the PVDD power supply was measured with the amplifier at idle switching at 600 kHz.

Table 1-7. R_p , Dissipation Factor, and Idle Power Measured for 10 Inductors

Inductor	Nominal Inductance (µH)	Inductance at 1 A (µH)	R_p at 1 A (kΩ)	Dissipation Factor at 1 A	PVDD Idle Power (W)
1	7	7.355	4.28	0.0064	1.0944
2	10	10.63	8.58	0.0047	0.9072
3	7	6.688	1.1	0.0227	2.2248

Table 1-7. R_p , Dissipation Factor, and Idle Power Measured for 10 Inductors (continued)

Inductor	Nominal Inductance (μH)	Inductance at 1 A (μH)	R_p at 1 A (k Ω)	Dissipation Factor at 1 A	PVDD Idle Power (W)
4	10	9.05	1.5	0.0227	1.692
5	7.3	7.38	1.04	0.0266	3.7944
6	10	9.42	0.568	0.062	3.2832
7	10	11.59	1.08	0.04	3.1608
8	7.6	7.16	0.494	0.055	4.7232
9	8.2	8.82	2.6	0.0126	1.4544
10	7	7.626	3.54	0.0081	1.188

From the data, it is evident that higher measured values of R_p result in lower power dissipation from the PVDD rail and thus higher system efficiency. Inductors 1 and 5 have nearly identical measured inductance, but the power dissipation at idle is over 3 \times higher for inductor 5. This power dissipation can be attributed to core loss because the inductance, and thus ripple current, are identical. Also note that PVDD power dissipation is measured at idle, where the DCR of the inductors contribute minimal loss.

1.4.5 DC Resistance (DCR)

Inductor DCR, R_S from Figure 1-26, is the series electrical resistance of the wire used to make the windings in an inductor. This resistance is measured at DC so that the impedance of the inductor with frequency does not affect the measurement.

Although the DCR is usually quite low, at high output current, the DCR can contribute considerable power losses for the audio signal. Losses due to DCR are simple to calculate, because it is series resistance.

$$\text{Power}_{\text{DCR}} = I_{\text{OUT}}^2 \times \text{DCR}(\Omega) \quad (14)$$

For a class-D amplifier, the calculation for the current flowing through the inductor is easy, because the signal voltage across the load and the load resistance are measurable. The inductor DCR can be measured or taken from the data sheet.

For a BTL amplifier, it is important to remember that there are two inductors in series with the load (one inductor for each side of the output bridge), therefore the DCR power loss for a single BTL channel is 2 \times the loss of just one inductor.

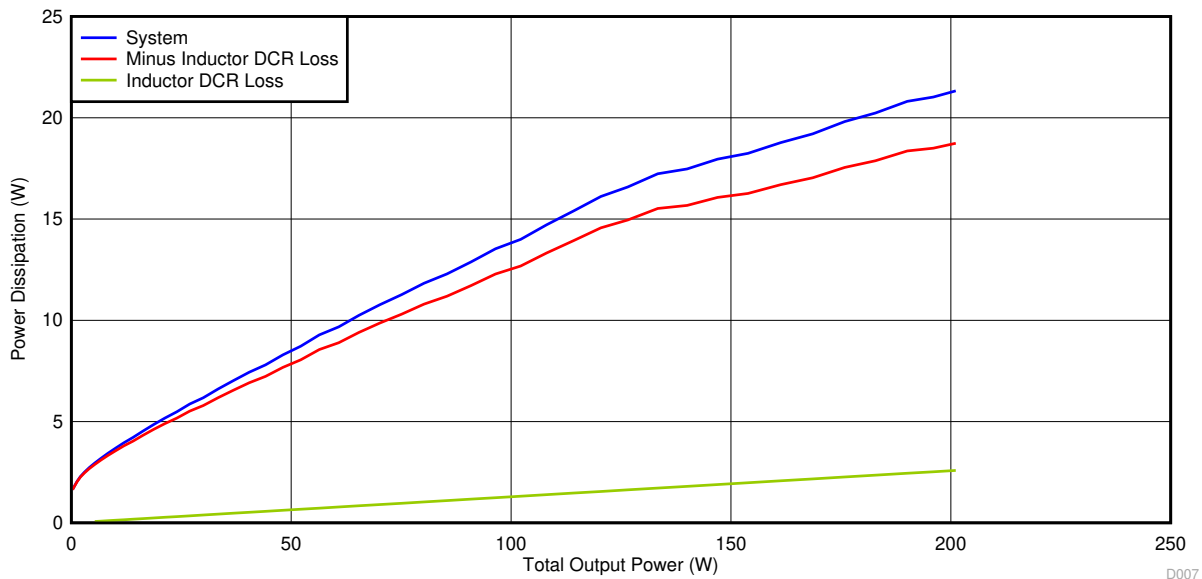

Figure 1-27. TPA3251 Power Dissipation With Inductor DCR PVDD = 30 V, 600 kHz, 2 \times BTL, 4 Ω

Figure 1-27 shows the measured power dissipation of the TPA3251 amplifier compared to the total output power in a 2× BTL configuration. The *system* curve shows the total power dissipation of the system. The *Inductor DCR Loss* curve shows the calculated power dissipation in the inductor due to DCR losses only.

By subtracting the system power dissipation from the inductor DCR loss, a better estimate of the actual device power dissipation can be made; this curve is labeled *Minus Inductor DCR Loss*. Note that core loss has not been taken into account.

1.4.6 Inductor Study With the TPA3251 Device

Due to the high power and superb audio performance of the TPA3251 amplifier, this device was used as a test platform to illustrate inductor performance. Unsurprisingly, a very wide range of performance has been found solely due to the inductor properties discussed earlier.

Note

For the TPA32xx family of devices, 7 μH to 10 μH is the recommended range of inductance based on a balance between power dissipation, performance, and filter cut-off frequency. For this reason, most of the inductors tested were within this inductance range.

The following tests were performed with the TPA3251 device set up in 2× BTL outputs with 4- Ω loads. The PWM switching frequency was set to 600-kHz switching with a PVDD supply of 36 V.

LCR meter tests include:

- Inductance measurements (1 A and 7 A of current at 600 kHz)
- Series resistance at 1 A, R_S
- Parallel resistance at 1 A, R_P
- Dissipation factor at 1 A

With the TPA3251 amplifier, inductors were tested for:

- THD+N vs power performance
- THD+N vs frequency at 20 W
- PVDD power at idle
- PVDD power at 20 W per channel

1.4.6.1 Results

Table 1-8. Results of Various Inductors

LCR Inductor Tests — 600-kHz, 2-V Test Signal									TPA3251 Testing—36 V, 600 kHz, 4 Ω, 2× BTL Channels	
MFR	Part No.	Nominal Inductance (μH)	Inductance at 1 A (μH)	Inductance at 7 A (μH)	ΔL, 1 to 7 A (%)	R _S at 1 A (mΩ)	R _p at 1 A (kΩ)	Dissipation Factor at 1 A	PVDD Idle Power (W)	PVDD Power at 20 W / CH (W)
CoilCraft	MA 10uH	10	10.63	10.64	0.09	187	8.58	0.0047	0.9072	48.348
CoilCraft	MA 7uH	7	7.355	7.366	0.15	179	4.28	0.0064	1.0944	48.456
CoilCraft	MSS1278-103	10							1.9368	48.96
CoilCraft	MSS1278T-682	6.8							2.3904	48.888
CoilCraft	XAL1010-103MEB	10							2.448	52.992
CoilCraft (dual inductor)	UA8013-AL	7							2.556	48.888
CoilCraft (dual inductor)	UA8014-AL	10							1.6776	48.384
TDK	B82559A5682A20	6.8							1.8792	47.952
TDK	B82559A7103A20	10							1.5192	47.808
Toko	DFEG12060-8R2M	8.2	8.82	7.78	-13.37	423	2.6	0.0126	1.4544	48.456
Toko	FDA1254-H-8R0	8							2.0304	48.24
Würth	7443551730	7.3	7.38	6.5	-13.54	774	1.04	0.0266	3.7944	51.408
Würth	7443556680	6.8							4.4928	50.256
Würth	7443557760	7.6	7.16	5.95	-20.34	1486	0.494	0.055	4.7232	51.624
Würth	7443630700	7	6.688	6.684	-0.06	577	1.1	0.0227	2.2248	49.248
Würth	7443631000	10	9.05	9.05	0	777	1.5	0.0227	1.692	48.672
Würth	74435561100	10	11.59	10.9	-6.33	1748	1.08	0.04	3.1608	50.04
Würth	74435571100	10	9.42	8.32	-13.22	2180	0.568	0.062	3.2832	50.904
Sagami	7G13A-100M-R	10							1.4832	48.384
Sagami	7G14C-100M-R	10							1.5264	48.816
Sagami	7G14A-100M-R	10							1.3536	48.024
Sagami	7G13C-100M-R	10							1.5984	48.24
Sagami	7G14J-100M-R	10							1.2168	48.024

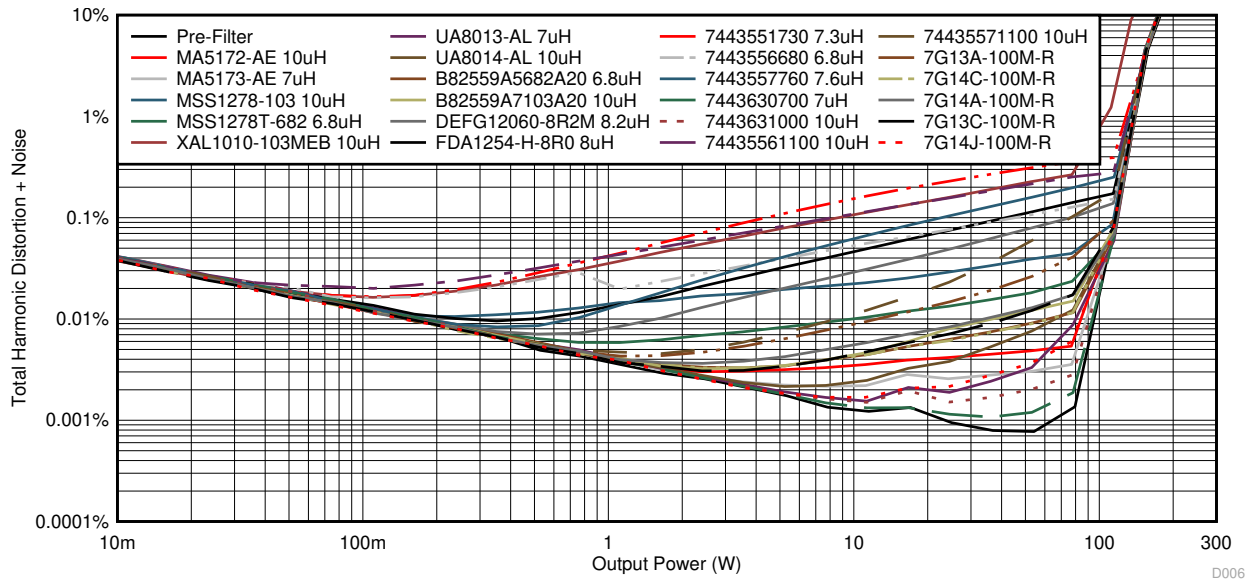

Figure 1-28. TPA3251 THD+N vs Output Power for Various Inductors 600 kHz, 36 V, 4 Ω

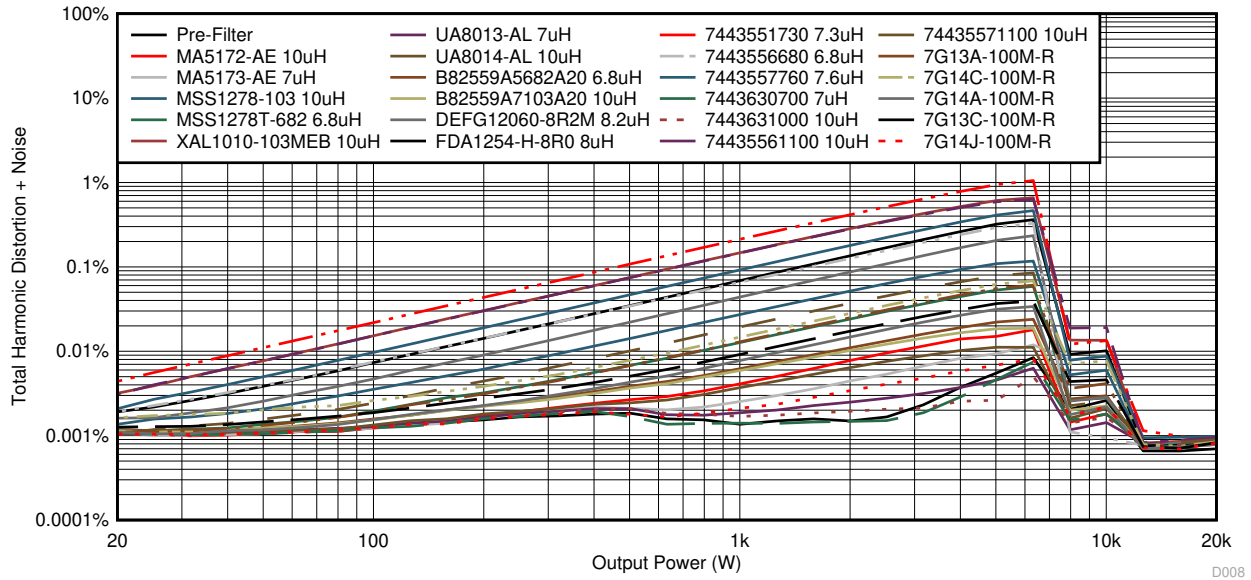

Figure 1-29. TPA3251 THD+N vs Frequency for Various Inductors 20 W, 600 kHz, 36 V, 4 Ω

Based on the inductors tested with the TPA3251 device, a few suitable inductors for high performance class-D audio were found. Any of these inductors are good candidates for the TPA32xx class-D amplifier family, assuming the target output power and performance goals for the end application can be satisfied with the inductor.

The recommended inductors were then rated against each other for audio performance, core loss, DCR, and size using a low-to-high (1 is low, 5 is high) 1–5 point scale based on the tests performed.

Table 1-9. Recommended Inductors With the TPA32xx Class-D Family

Inductance (μH)	Part Number	Manufacturer	Audio Performance (1–5)	Core Loss (1–5)	DCR (1–5)	Size (1–5)
10	MA5172-AE	CoilCraft	2	1	5	4
7	MA5173-AE	CoilCraft	4	1	4	4
10	UA8014-AL	CoilCraft	1	3	1	1
7	UA8013-AL	CoilCraft	3	5	1	1
10	7443631000	Würth	5	3	2	5
7	7443630700	Würth	5	4	2	
10	7G14J-100M-R	Sagami	4	2	3	3

1.4.6.2 Conclusion

From the results of the inductor study with the TPA3251 device, it is clear that the inductor plays a large role in the audio performance and total system power dissipation. Inductance value, DCR, linearity, and core loss factor into the total system performance and must be considered based on the design goals of a specific application.

For the TPA32xx family of devices, a 7- μH inductor is a better value for performance-oriented applications due to improved linearity and generally improved distortion performance over higher inductances. However, for a more power-efficient system, 10- μH may be a better selection due to the reduced ripple current with a slight penalty on performance.

In both cases, core loss must be considered as well as DCR. Although a 10- μH inductor may show improved power dissipation for low output power due to reduced ripple current, if it has high DCR, the losses may be greater at high currents than a 7- μH inductor with higher ripple current.

1.5 Capacitor Considerations

Capacitor component selection is critical to maintain flat LC filter frequency response and minimize distortion for the best audio performance. There are a number of capacitor types available including film, ceramic, and electrolytic. This section discusses the key parameters and trade-offs for choosing a capacitor for high-power class-D audio-amplifier applications.

For capacitor recommendations to use with Texas Instruments class-D audio amplifiers, see the device evaluation module (EVM) and EVM user's guide.

1.5.1 Class-D Output Voltage Overview

The capacitor in the class-D output LC low-pass filter is critical to the frequency response of the amplifier.

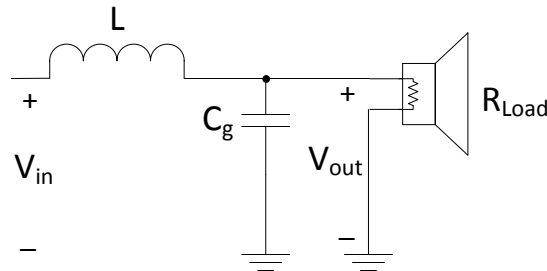

Figure 1-30. Class-D SE Filter - AD or BD Mode

Changes in capacitance due to temperature, voltage, current, or other factors affect the location of the corner frequency and ultimately the audio performance.

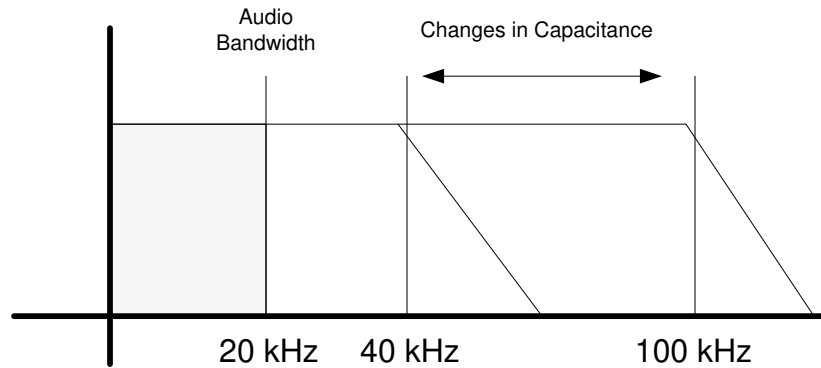

Figure 1-31. LC Filter Frequency Response

To select the appropriate capacitor, Figure 1-32 shows an audio sine-wave signal after the class-D LC-filter and the corresponding voltages.

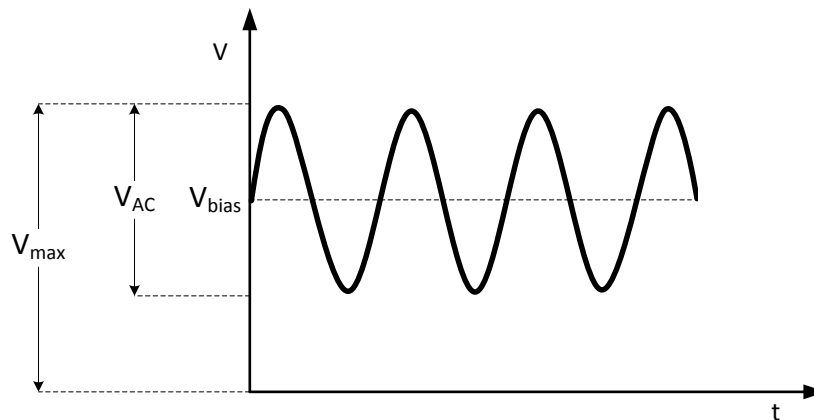

Figure 1-32. Class-D LC Filter Output

Parameter	Description	Value	Units
V_{\max} ⁽¹⁾	Maximum peak voltage	—	VDC
V_{bias} ⁽²⁾	DC bias voltage	—	VDC
V_{AC} ⁽³⁾	Peak-to-peak AC voltage	—	V_{PP}

- (1) V_{\max} is the maximum peak voltage including the AC and DC output voltages.
 (2) V_{AC} is the AC audio voltage.
 (3) V_{bias} is the DC offset voltage found on most single-supply class-D amplifiers. The bias voltage is half of the power-supply voltage. In BTL applications, the DC voltage cancels out across the speaker. In single-ended applications, an ac-coupling capacitor is required to block the DC voltage.

1.5.1.1 Ripple Voltage

Ripple voltage is caused by the inductor charge and discharge cycles. The ripple voltage appears as a triangle waveform overlaid on the sine wave output. The capacitor in the LC filter is responsible for filtering this ripple to smooth the audio signal. This ripple voltage across the capacitor creates an AC current in the capacitor, resulting in power dissipation. Overheating can occur if the capacitor is not rated to handle this current.

1.5.1.2

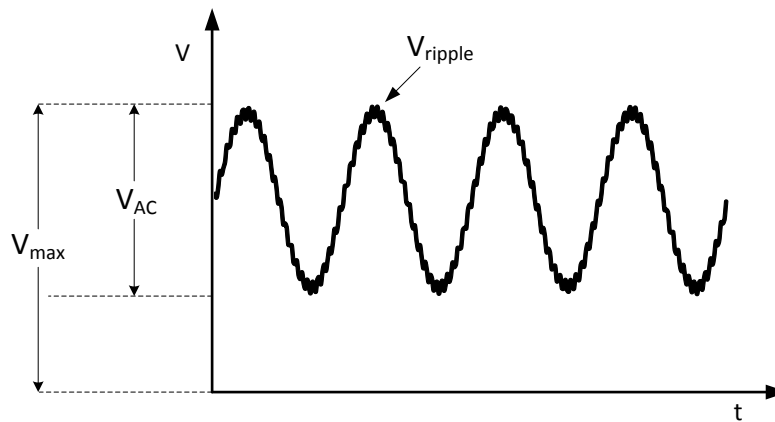

Figure 1-33. Class-D LC Filter Output With Ripple

Parameter	Description	Value	Units
V_{\max}	Maximum peak voltage	—	V_{DC}
V_{AC}	Peak-to-peak AC voltage	—	V_{PP}
V_{ripple}	Ripple voltage	—	V_{PP}

1.5.2 Capacitor Ratings and Specifications

To ensure the capacitor has minimal impact on the audio quality, here are a few key parameters to consider when selecting a capacitor.

Capacitor manufacturers provide a number of ratings and specifications for using capacitors safely in a system. This section briefly describes the ratings and specifications associated with capacitors and how to use them in context of class-D audio signals.

Table 1-10 is a table listing common parameters for capacitors. Some parameters are found more often with certain types of capacitors than others due to the construction and the dielectric material of the capacitor.

Table 1-10. Capacitor Ratings and Specifications

Parameter	Description
Capacitance	The primary functional parameter of a capacitor, characterizing the ability to store charge. The capacitance values available vary by technology, rated voltage, and size. Manufacturers provide part-to-part capacitance variation in the datasheet.
Maximum voltage (V_{MAX}) or rated voltage	The absolute peak voltage (DC, AC, or pulse) for safe operation of the capacitor. This is the highest voltage the capacitor should see, including the audio signal, ripple from switching, and any voltage overshoot.
Maximum temperature rise (rated AC voltage and AC current)	The maximum AC rms voltage or AC current allowed that causes capacitor self-heating. Typically based on a sine wave, this rating is a measure of the AC signal only. Using voltages or currents higher than the permissible value could lead to capacitor overheating and damage.
Pulse rise time (dv/dt) or peak current (I_{peak})	Defines the capability of a capacitor to withstand high peak currents due to fast voltage changes typically measured in volts per microsecond ($V / \mu s$). This is similar to the rated AC voltage, but for waveforms like pulses or square waves. Sometimes the "pulse rise time" is specified in terms of peak current rather than a voltage. Typically, the "pulse rise time" is important for film type capacitors due to construction and not as relevant for other capacitor types and may not be listed. In most LC filter applications less than 100 kHz, the pulse rise time is not violated.
Equivalent series resistance (ESR)	A resistance in series with the capacitor representing the power losses in the capacitor. It is the sum of the resistance in the leads and losses in the dielectric. ESR is used to estimate the power losses in the capacitor that cause temperature increases due to AC ripple current.
Dissipation factor (DF)	The ratio of all the capacitor purely resistive losses to the capacitor reactance at a specific frequency. Another way to determine the power losses in a capacitor similar to ESR.
Dielectric material	Insulating material between the two conductors in a capacitor.
Mounting	The assembly required for soldering the capacitor to the board; either surface mount (SMT) or thru-hole.

To help narrow the capacitor selection quickly, begin by considering the following:

- Capacitance – with a typical inductance of 7 μH or 10 μH in the LC filter, a capacitor value of 0.68 μF or 0.47 μF provides a corner frequency around 73 kHz to maximize the bandwidth of the TPA32xx class-D amplifier.

Inductance (μH)	Capacitance (μF)	Corner Frequency (kHz)
7 μH	0.68 μF	72.9 kHz
10 μH	0.47 μF	73.4 kHz

- Capacitor type – most high-power audio applications use either metalized film (MF) capacitors or ceramic capacitors. For best audio performance across temperature, voltage, current, and frequency, metalized film capacitors or similar are recommended over ceramic capacitors. Ceramic capacitors may be used in very size-constrained applications and should be tested thoroughly for reliability purposes, but audio performance may suffer.
- Voltage Rating – the AC and DC voltage requirements differ between metalized film capacitors and ceramic capacitors. Depending on the capacitor type, see the appropriate following section.
 - Metalized film capacitors – metalized film capacitors are less susceptible to capacitance voltage derating like ceramic capacitors; however, due to construction, they have a voltage slew-rate (dv/dt) limit (or peak permissible current) to prevent damage to the thin-film layers.

For a 50-V peak-to-peak audio output and an LC filter corner frequency of approximately 73 kHz, then the slew rate is approximately 23 $V / \mu s$. The suggested minimum dv/dt is 100 $V / \mu s$ to provide margin. In general, most metalized film capacitors meet the requirements of audio signal slew-rates.

- Ceramic Capacitors – as a guideline, ceramic capacitors reduce in capacitance value by the same percentage of operating voltage to the rated voltage.

$$C_{\text{derated}} = C_{\text{rated}} \times (1 - V_{\text{applied}} / V_{\text{rated}})$$

For example, when 50 V is applied to a 100-V rated capacitor, the capacitance decreases by about 50%. Most capacitor vendors provide a capacitance vs voltage curve for exact deratings.

To prevent changes in the LC filter over frequency, a ceramic capacitor voltage rating of > 150 V is mandatory, 250 V is recommended.

- Equivalent series resistance (ESR) – the capacitor equivalent AC resistance at a specific frequency causes power losses in the capacitor. For high-power audio applications, low ESR is critical to reduce losses in the capacitor. A peak ESR value of 1 Ω at low frequencies is recommended, with lower ESR values at higher frequencies. See the ESR vs frequency graph provided by most capacitor manufacturers.
- Maximum temperature rise (rated AC voltage and AC current) – the maximum allowable AC current that produces an acceptable increase in temperature due to dielectric power losses (ESR). For high-power audio applications this is important to consider because AC ripple current could be substantial through the capacitor.

1.5.2.1 Maximum Voltage or Rated DC Voltage

The maximum rated voltage is the absolute maximum voltage across the terminals of the capacitor. This maximum includes AC signals, DC offsets, and overshoots due to ringing.

Single-supply class-D amplifiers will have an AC voltage with a DC offset at half of the power supply. The best representation of audio is *DC + AC Voltage* and *AC Voltage*.

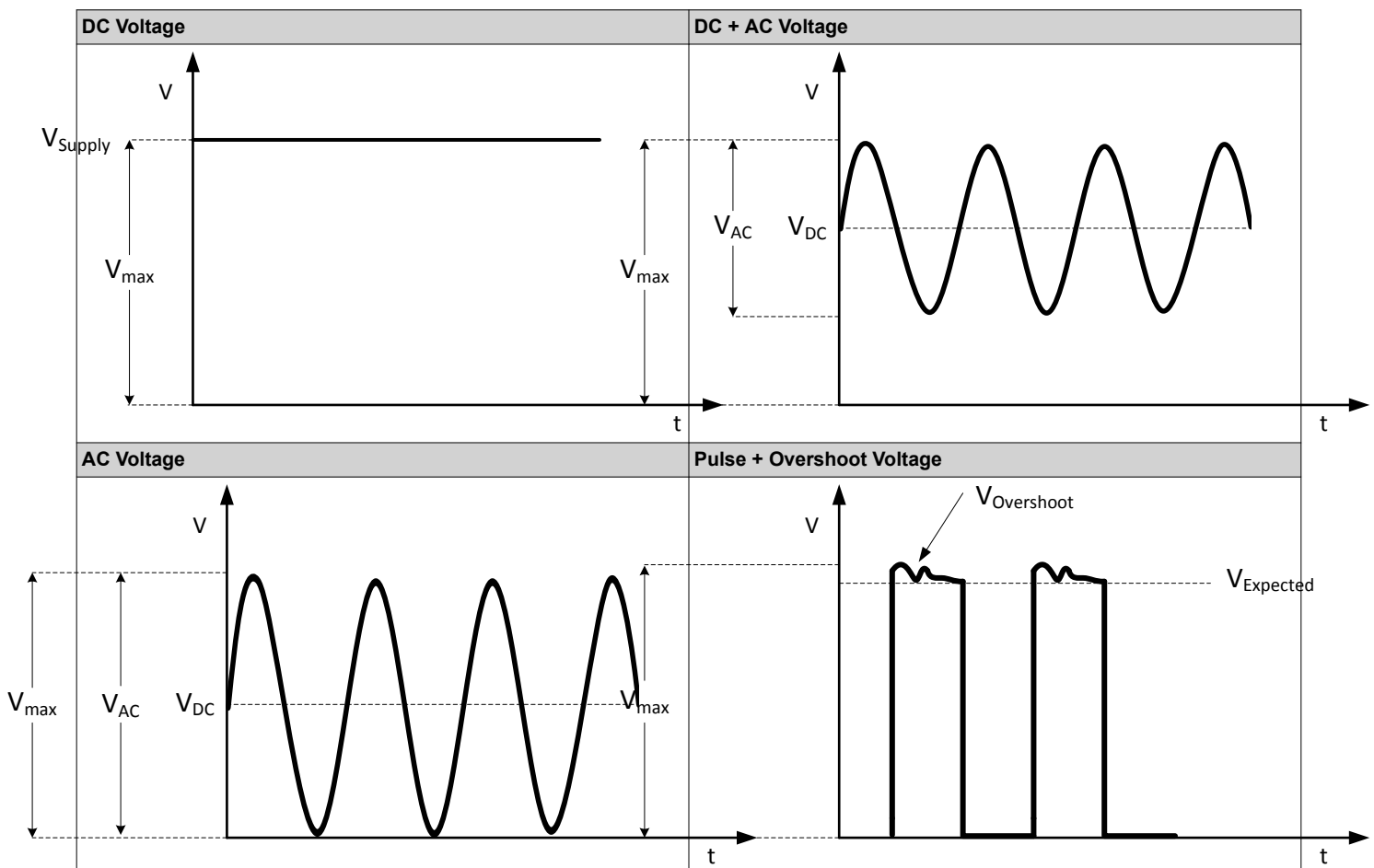

Estimate the maximum voltage across the capacitor using Equation 15:

$$V_{Cap_max} = \frac{V_{Supply}}{2} + \frac{\sqrt{2}}{2} \times \sqrt{P_{Max} \times R_{Load}} \quad (15)$$

Parameter	Description	Units
V_{Cap_max}	LC filter capacitor maximum peak voltage	VDC
V_{Supply}	Supply voltage	VDC
P_{Max}	Maximum output power	W
R_{Load}	Load resistance	Ω

1.5.2.2 ESR and Dissipation Factor

Equivalent series resistance (ESR) and dissipation factor are fairly interchangeable ways to estimate the losses in the capacitor. See Section 1.5.2.3 to estimate the power losses using ESR or dissipation factor.

ESR is represented as a resistance in series with an ideal capacitor. ESR is a simple way to estimate the losses within the capacitor. Figure 1-34 depicts the ESR resistor.

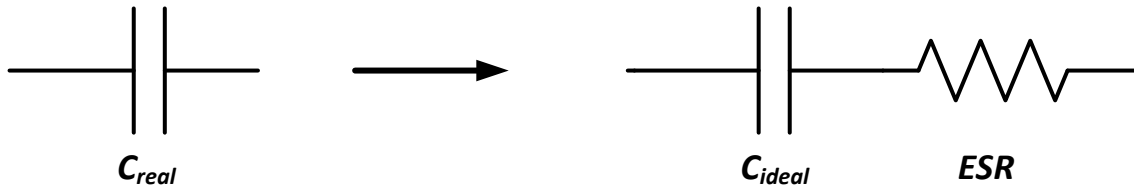

Figure 1-34. Equivalent Series Resistance

Dissipation factor is a slightly different measurement and is used primarily to compare the quality of a capacitor. It is the ratio of the ESR to the capacitance reactance. The dissipation factor includes the losses due to the dielectric material reactance, which when comparing different capacitor technologies makes it easier to understand which capacitor has less losses.

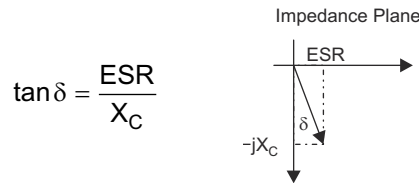

Figure 1-35. Dissipation Factor

A lower dissipation factor means less power loss.

1.5.2.3 Maximum Temperature Rise (Rated AC Voltage and AC Current)

Capacitor manufacturers provide a maximum temperature rise or operating temperature to prevent overheating of the capacitor. For convenience, most manufacturers provide AC voltage or current limits that correspond to the maximum temperature limit. The maximum rms voltage and current are typically provided in a graph versus frequency. The AC voltage and current limits provide a way to limit power dissipation and prevent capacitor overheating.

For audio LC filter applications, the losses due to AC voltage and current are a result of the ripple voltage from the inductor charge and discharge cycles. The charge and discharge cycle frequency occurs at the class-D switching frequency.

To estimate power losses and temperature rise, first use the ripple current calculation in [Equation 12](#) and then use the following equations for power losses in the capacitor.

Note

It is always good practice to calculate the temperature rise due to AC voltage and current through the capacitor using ESR or dissipation factor.

ESR			Dissipation Factor		
$P_{\text{losses}} = \frac{V_{\text{ripple}}^2}{\text{ESR}} = I_{\text{ripple}}^2 \times \text{ESR} \quad (16)$			$P_{\text{losses}} = V_{\text{ripple}}^2 \times 2\pi \times f \times C \times \tan \delta \quad (17)$		
Parameter	Description	Units	Parameter	Description	Units
P_{losses}	Power Dissipation in Capacitor	W	P_{losses}	Power Dissipation in Capacitor	W
V_{ripple}	RMS Ripple Voltage	V_{RMS}	V_{ripple}	RMS Ripple Voltage	V_{RMS}
I_{ripple}	RMS Ripple Current	I_{RMS}	f	Ripple Frequency	Hz
ESR	Equivalent series resistance	Ω	C	Capacitance	F
			$\tan \delta$	Dissipation Factor	-
Note Use the ESR value at the same frequency as the ripple current.			Note Use the dissipation factor value at the same frequency as the ripple current.		

Using the power losses calculated in [Equation 16](#) and [Equation 17](#), the capacitor temperature due to self-heating can be calculated using the heat coefficient in the capacitor data sheet. Typically, there is a heat coefficient represented as the ratio of temperature rise to the power dissipated in watts. The thermal coefficient typically takes into account the capacitor size and surface area.

$$\text{Thermal Coefficient} = \Delta^\circ\text{C} / \text{W} \quad (18)$$

[Equation 18](#) is read, "For every 1 W of power dissipated, there is a temperature change of $\Delta^\circ\text{C}$."

Note

Audio Importance

Rated AC voltage or current is very important for high-power audio applications, because of high ripple currents passing through the capacitor. Be sure to verify the capability of the chosen capacitor in the data sheet and measure temperature under worst-case conditions.

1.5.2.4 Pulse Rise Time (dv/dt) or Peak Current (I_{peak})

Pulse rise time or peak current is often specified as an alternative to a rated AC voltage for pulse-type waveforms (non-periodic); however, for a metalized film capacitor (MFC) it has a more-important meaning beyond temperature.

MFC capacitor structure and materials make them susceptible to high dv/dt voltage rise times or alternatively peak current. Violating pulse rise time (dv/dt) can result in permanent damage to the capacitor and loss of capacitance.

Calculate the rise time of the inductor voltage ripple and ensure that it is below the listed value in the capacitor data sheet.

$$V_{Cap_max} = \frac{V_{Supply}}{2} + \frac{\sqrt{2}}{2} \times \sqrt{P_{Max} \times R_{Load}} \quad (19)$$

Parameter	Description	Units
V_{Cap_max}	LC filter capacitor maximum peak voltage	V_{DC}
V_{Supply}	Supply voltage	V_{DC}
P_{Max}	Maximum output power	W
R_{Load}	Load resistance	Ω

$$\text{Max Pulse Rise Time} = 2\pi \times f \times V_{Cap_max} \quad (20)$$

Parameter	Description	Units
V_{max}	Maximum peak voltage	V_{DC}
V_{AC}	Peak-to-peak AC voltage	V_{pp}
V_{ripple}	Ripple voltage	V_{pp}

1.5.3 Capacitor Types

This section provides more detail and key parameters to consider for each type of capacitor.

1.5.3.1 Selecting a Capacitor Type

There are a number of different materials and manufacturing techniques for building a capacitor. Here is a brief summary of the three main categories of capacitors. However, note that there can be significant differences between capacitors of the same category, so use the capacitor data sheet to determine the actual performance and behavior of each capacitor.

[Table 1-11](#) compares key capacitor parameters as a quick overview of the trade-offs between each type. For the higher-voltage class-D amplifiers, the metalized film capacitors are most common and the electrolytic capacitors are almost never used in LC filters.

Table 1-11. Capacitor Type Comparison

	Metalized Film	Ceramic	Electrolytic
Common names or variations	Metalized film capacitor (MFC), polypropylene, polyester	Multi-layer ceramic capacitor (MLCC)	Aluminum, tantalum, POSCAP
Capacitance range	100 pF–10 μ F	1.5 nF–47 μ F	0.1 μ F–3 F
Maximum DC-rated voltage range	40 V–2000 V, dependent on temperature	6.3 V–2500 V	1.4 V–500 V
Polarized	No	No	Yes
Mounting	Thru-hole typical, surface mount options	Surface-mount, thru-hole	Thru-hole
Size	Small	Smallest	Large
Temperature tolerance	Best	Good	Poor
Lifetime	Acceptable	Acceptable	Limited
Failure mode	Self-healing	Short	
Price	\$\$\$	\$\$	\$
Recommend for class-D applications	Yes, higher power (>100 W)	Yes, lower power (<100 W)	No
Audio distortion	Best	Worst	Good

[Table 1-12](#) provides an overview of the main contributors to changes in the capacitance for each capacitor type.

Table 1-12. Capacitor-Type Tolerance Comparison

	Metalized Film	Ceramic	Electrolytic
Stable across	Voltage and temperature	—	Voltage
Temperature (–55°C to 85°C)	< 5%	X5R ⁽¹⁾ \pm 15%	< 20%
Temperature (–55°C to 125°C)	< 5%	X7R ⁽¹⁾ : \pm 15%	< 20%
Frequency	< 2.5%	< 10%	< 50%
DC bias voltage	< 2 %	Between 20%–80% (dependent on capacitor rated voltage)	< 2%

(1) Ceramic letter codes – X = low temperature of –55°C, 5 = 85°C, 7 = 125°C, R = change in capacitance over temperature range

[Table 1-13](#) compares the key reliability parameters for each type of capacitor. These parameters are important when considering the current and voltage capability of a capacitor.

Table 1-13. Capacitor Reliability Parameter Comparison

	Metalized Film	Ceramic	Electrolytic
RMS or permissible current	Highest	High	High, up to 4 A
Pulse rise time (dv/dt)	Reliability concern if violated	Not typically a concern	Not typically a concern
Equivalent series resistance (ESR)	Lowest ESR, < 1 Ω		
Dissipation factor (1 kHz)	Lowest, < 0.008 (< 0.01%)	Lower, 0.01– 0.05	Highest, 0.08–0.2

1.5.3.2 Metalized Film Capacitors

[Table 1-14](#) lists and describes parameters that are important for selecting metalized film capacitors.

Table 1-14. Film-Capacitor Key Parameters

Parameter	Description
Pulse rise time (dv/dt)	Defines the capability of a capacitor to withstand high peak currents due to fast voltage changes, typically measured in volts per microsecond (V / μ s). Typically, the pulse rise time is important for film type capacitors, because high currents can damage the connections to the capacitor film-metal structure.
AC voltage rating	The maximum AC rms voltage or AC current allowed that causes capacitor self-heating
Temperature coefficient	The temperature coefficient for a film capacitor is much better than ceramic capacitors, with typically less than 3% change over temperature.

1.5.3.2.1 AC Voltage or Current Rating

Most film capacitor manufacturers provide a rated AC voltage or AC current graph that shows the safe AC operating range of the capacitor. The AC voltage or current rating is provided to limit the power dissipation and the heating of the capacitor.

The AC voltage or current rating is only the AC portion of the waveform. DC bias is not considered for this parameter; however, the AC + DC voltage should not violate the maximum-rated DC voltage parameter.

The graphs in [Figure 1-36](#) and [Figure 1-37](#) show the rated AC voltage of two different capacitors. Note that the DC voltage rating for both is 250 V; however, the AC voltage handling is much different. The Kemet capacitor in [Figure 1-36](#) handles more AC voltage than the Vishay in [Figure 1-37](#).

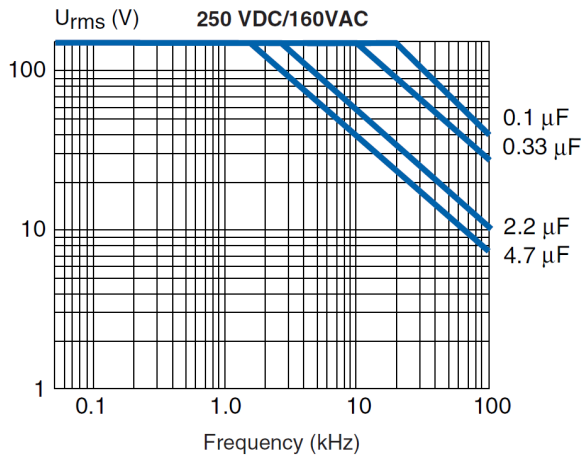

Figure 1-36. Kemet PHE426HB7100JR06 Capacitor

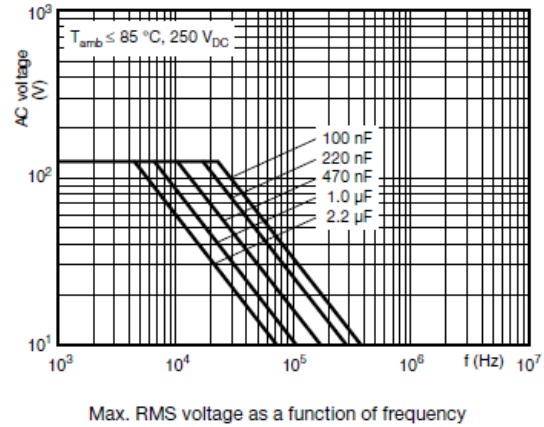

Figure 1-37. Vishay MMKP383 Capacitor

The voltage rating of most film capacitors is dependent on temperature as well. Manufacturers provide two graphs or a derating formula for temperatures above 85°C.

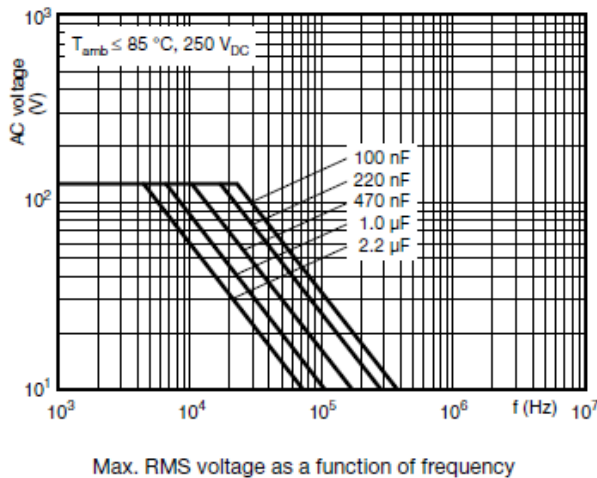

Figure 1-38. AC Voltage Rating less than 85°C

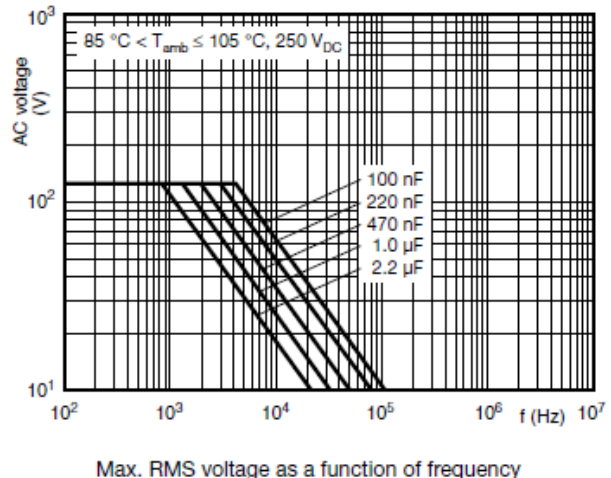

Figure 1-39. AC Voltage Rating between 85°C and 105°C

1.5.3.2.2 Temperature Coefficient

The change in capacitance over temperature is much better than for ceramic capacitors of X7R type, with typically less than 4% change over temperature. Figure 1-40 shows a graph taken from a Vishay film-capacitor data sheet showing the change in capacitance as a percentage of the nominal capacitance versus ambient temperature.

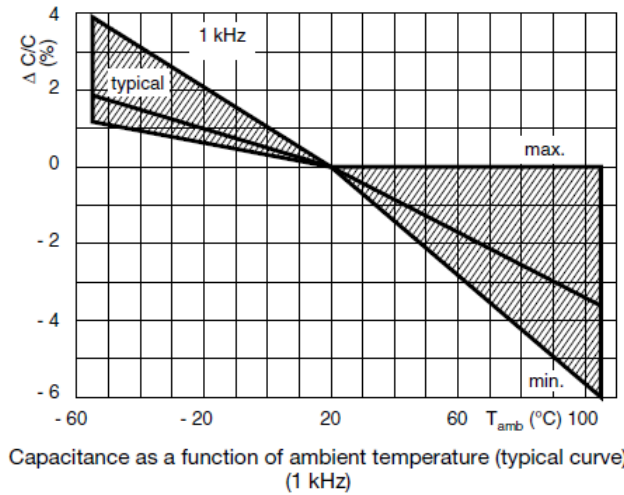

Figure 1-40. Film-Capacitor Temperature Coefficient

1.5.3.3 Ceramic Capacitors

Ceramic capacitors are some of the most standardized components used in electronics today. However, do not be fooled, ceramic capacitors can exhibit quite different behavior due to construction and materials. Table 1-15 lists and describes parameters that are important for selecting ceramic capacitors.

Table 1-15. Parameter and Descriptions for Selecting Metalized Film Capacitors

Parameter	Description
Size	Ceramics offer small sizes and packages, making them advantageous in size constrained applications.
DC bias voltage	The capacitance of ceramic capacitors reduces with an increase in DC voltage (not ac).
Temperature coefficient	Ceramic capacitors have a standard temperature-coefficient letter code. Ceramic capacitors of type X7R will have $\pm 15\%$ change in capacitance over temperature.
AC ripple voltage and self heating	The maximum AC rms voltage or AC current allowed that causes capacitor self-heating. Not always indicated in the datasheet, but most manufacturers require a maximum increase in temperature due to self-heating of 10°C – 20°C .
Reliability	Ceramic material is brittle, making it susceptible to cracks from vibration and flexing.

1.5.3.3.1 Size

Small size is one of the biggest advantages of ceramics; however, with increased capacitance and rated voltage the capacitor sizes can grow.

For example, a capacitor of X7R type, 1 μF , and rated for 200 V is available in a large 2225 standardized surface mount package size.

Parameter	Value	Unit
Capacitance	1	μF
Voltage rating	200	VDC
Temperature coefficient	X7R	—
Standard size	2225 or 3640	—

Ceramic capacitor manufacturers offer surface-mount and leaded packages. They also offer various dielectric materials that offer more stable capacitance across voltage, temperature, and frequency.

1.5.3.3.2 DC Bias Voltage

DC bias voltage is important to consider for a ceramic capacitor, because the capacitance changes based on the DC voltage applied. The DC bias voltage effect is due to the dielectric properties of ceramic capacitors.

The capacitor manufacturer can provide a graph that shows the capacitance change versus DC voltage applied, similar to the graph in [Figure 1-41](#). Use this graph to ensure that the capacitance is acceptable at the DC bias voltage.

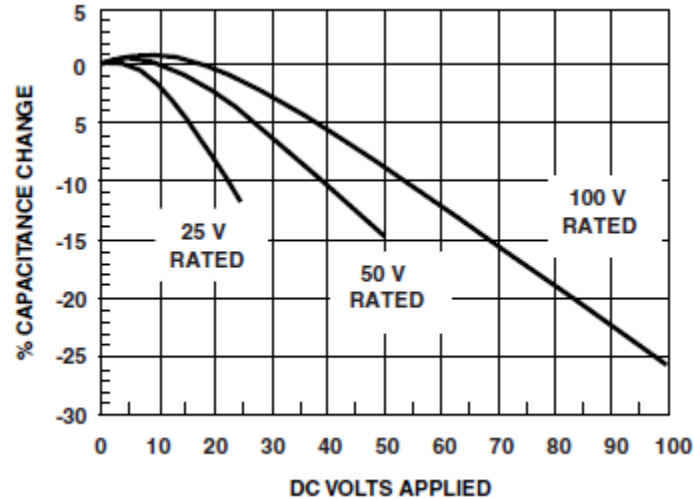

Figure 1-41. Ceramic Capacitor % Capacitance Change vs DC Voltage

1.5.3.3.3 Temperature Coefficient

Ceramic capacitors of IEC or EIA class-II standards are intended by definition for high volumetric efficiency (small size) and for filter applications. The industry has adopted a letter-code standard to indicate the approximate capacitance change over temperature.

The code consists of 3 letters with the following meaning:

- 1st letter – the lowest operating temperature
- 2nd letter – the highest operating temperature
- 3rd letter – the change in capacitance over temperature

For example, the X7R code is read: “From -55°C to 125°C the capacitance value could vary from 15 percent to -15 percent.”

X 7 R

The remaining code options are shown in [Table 1-16](#).

Table 1-16. Remaining Code Options

Minimum Temperature Code	Maximum Temperature Code	% Change in Capacitance Over Temperature Range
X = -55°C	4 = 65°C	P = ±10%
Y = -30°C	5 = 85°C	R = ±15%
Z = 10°C	6 = 105°C	S = ±22%
	7 = 125°C	T = 22% to -33%
	8 = 150°C	U = 22% to -56%
	9 = 200°C	V = 22% to -82%

For best performance and for applications where ceramic capacitors are the preferred choice due to size, a ceramic capacitor with code X7R is recommended.

1.5.3.3.4 Reliability

Standard ceramic capacitors are brittle and not flexible, making them susceptible to damage from vibrations and board flexing. For applications that have heavy vibrations or board flexing, consult with the capacitor vendor for the best solution.

1.6 Related Collateral

Use the following link to access the *Class-D LC Filter Designer (LCFILTER-CALC-TOOL)*: ([SLAC729](#)).

2 Reference

3 Reference

4 Revision History

Changes from Revision A (November 2016) to Revision B (June 2026) **Page**

- Added [Table 1-1](#) 2
 - Updated the numbering format for tables, figures, and cross-references throughout the document..... 2
-

Changes from Revision * (October 2016) to Revision A (November 2016) **Page**

- Added *Related Collateral* section with link to LCFILTER-CALC-TOOL..... 41
-

IMPORTANT NOTICE AND DISCLAIMER

TI PROVIDES TECHNICAL AND RELIABILITY DATA (INCLUDING DATASHEETS), DESIGN RESOURCES (INCLUDING REFERENCE DESIGNS), APPLICATION OR OTHER DESIGN ADVICE, WEB TOOLS, SAFETY INFORMATION, AND OTHER RESOURCES "AS IS" AND WITH ALL FAULTS, AND DISCLAIMS ALL WARRANTIES, EXPRESS AND IMPLIED, INCLUDING WITHOUT LIMITATION ANY IMPLIED WARRANTIES OF MERCHANTABILITY, FITNESS FOR A PARTICULAR PURPOSE OR NON-INFRINGEMENT OF THIRD PARTY INTELLECTUAL PROPERTY RIGHTS.

These resources are intended for skilled developers designing with TI products. You are solely responsible for (1) selecting the appropriate TI products for your application, (2) designing, validating and testing your application, and (3) ensuring your application meets applicable standards, and any other safety, security, regulatory or other requirements.

These resources are subject to change without notice. TI grants you permission to use these resources only for development of an application that uses the TI products described in the resource. Other reproduction and display of these resources is prohibited. No license is granted to any other TI intellectual property right or to any third party intellectual property right. TI disclaims responsibility for, and you fully indemnify TI and its representatives against any claims, damages, costs, losses, and liabilities arising out of your use of these resources.

TI's products are provided subject to [TI's Terms of Sale](#), [TI's General Quality Guidelines](#), or other applicable terms available either on ti.com or provided in conjunction with such TI products. TI's provision of these resources does not expand or otherwise alter TI's applicable warranties or warranty disclaimers for TI products. Unless TI explicitly designates a product as custom or customer-specified, TI products are standard, catalog, general purpose devices.

TI objects to and rejects any additional or different terms you may propose.

Copyright © 2026, Texas Instruments Incorporated

Last updated 10/2025