

# Designing a Robust Traction Inverter Redundant Power Supply From 800 V Battery



Jacob Vasquez

## ABSTRACT

The market for automotive powertrain electrification products like the high-voltage (HV) traction inverter grows as consumers and regulating agencies demand fewer emissions. In response, manufacturers of hybrid and electric vehicles (xEV) have doubled the HV battery level. Increasing battery voltage from 400 V to 800 V decreases reliance on the internal combustion engine, decreases charging times, and improves driving range. But, changing battery voltage has implications especially regarding safety critical systems that operate during crash events or malfunction. For example, the redundant power supply, which has become common in traction inverter architectures, operates directly off the HV battery. This application note discusses key considerations for high-voltage to low-voltage (HV-LV) redundant power supply design using TI's automotive flyback controllers.

## Table of Contents

1 Introduction.....	2
2 Selecting Devices.....	3
3 Start-Up Circuitry.....	3
4 Noise Coupling.....	4
5 Safety.....	4
6 Summary.....	5
7 Related Documentation.....	5
8 Revision History.....	6

## List of Figures

Figure 1-1. Traction Inverter Block Diagram.....	2
Figure 3-1. Active Start-Up Circuit.....	3
Figure 3-2. Implementation to Support > 700 V Inputs.....	4

## List of Tables

Table 7-1. Flyback Controller Family Highlights.....	5
--	---

## Trademarks

All trademarks are the property of their respective owners.

## 1 Introduction

The traction inverter efficiently converts DC power from a high-voltage battery to alternating phases of power needed to drive multi-phase motors. Galvanic isolation is required to protect people, as well as the low-voltage components on the cold side of the system, from the high-voltage traction inverter on the hot side of the system. As automotive applications continue to trend in the direction of increased safety, it has become more common to include a high-voltage to low-voltage backup supply in the traction inverter system. The backup power supply powers the low-voltage components if the 12-V battery fails or the HV battery gets disconnected. Figure 1-1 displays an example block diagram featuring the high-voltage to low-voltage redundant power supply.

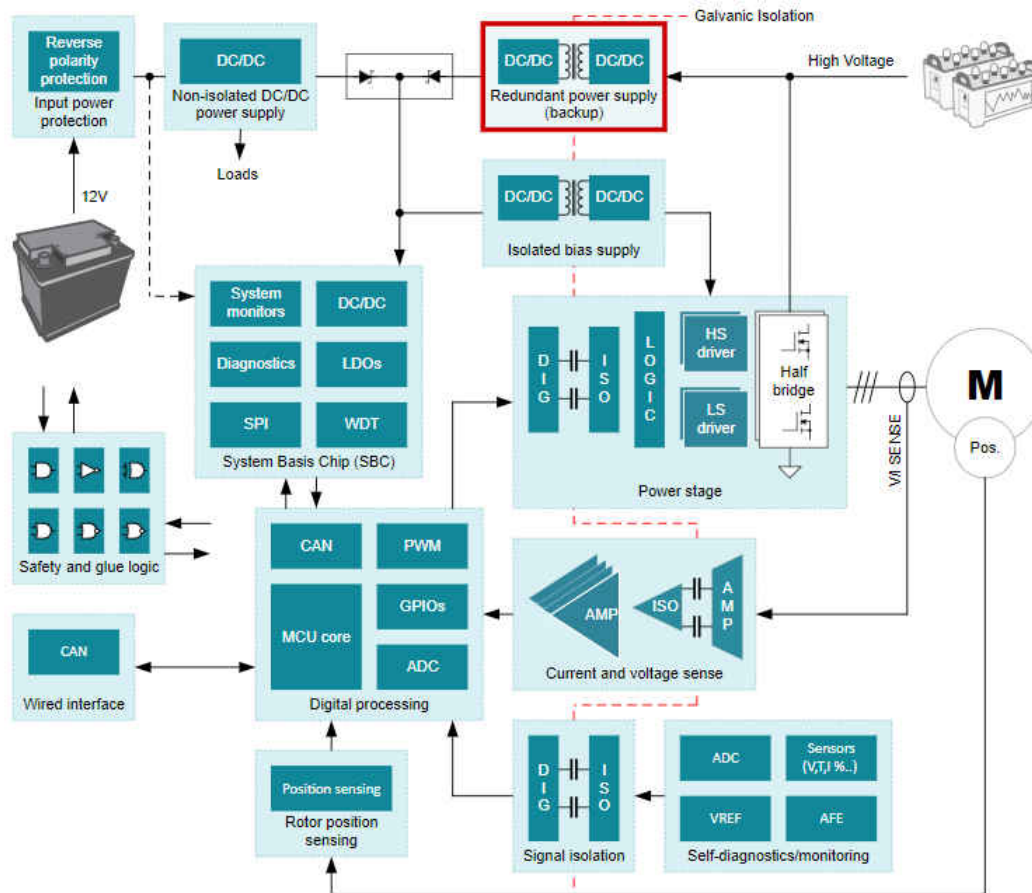

Figure 1-1. Traction Inverter Block Diagram

The flyback topology works for the redundant power supply because low cost, isolation, and flexibility. A flyback controller such as the [UCC28C56H-Q1](#), or the [UCC28700-Q1](#), is suitable for this application. For systems requiring the highest efficiency and power density, the [UCC28781-Q1](#) offers higher switching frequency, direct synchronous rectifier FET control, zero-voltage switching for minimal switching losses and EMI, and programmable adaptive burst mode for light and no load conditions.

The high-voltage input flyback converter needs to support ultra-wide input voltages. The backup supply may be required to operate down to between 40 V to 60 V depending on the architecture. This auxiliary supply can enable active discharge for the DC link capacitors or active short circuit for the motor. HV transients on the DC bus can exceed 1 kV in amplitude while lasting a few seconds, so a 1 kV maximum input-voltage may be required in 800-V battery systems for margin. In these cases, the analog controller and transformer selected must be designed accounting for limits on duty cycles and minimum on times, without sacrificing regulation accuracy or transient response, across the full load range.

Functional safety requirements dictate measures that protect testers and end users from potential risks during specific operating conditions. So, the powering the HV-LV backup supply from 800 V instead of 400 V presents

new and interacting design challenges. More specifically, these challenges are designing for ultra-wide input voltage range, with automotive rated HV power devices, and optimizing design performance based on cost and size constraints while ensuring the system meets safety requirements among others.

## 2 Selecting Devices

In general for automotive high voltage input flyback power supply designs, all component ratings should be optimized based on minimizing cost, without violating creep age and clearance rules. For example, a single larger bulk input capacitor might work, but it may be cheaper or smaller to use multiple smaller capacitors. Large components also can have larger parasitics, which can make complying with EMI regulations more difficult.

Many factors affect the design and selection of magnetic components like transformer and EMI filter inductor. Magnetics are especially critical for isolated topologies, since they play a significant role in determining the overall system performance. First, the components must be designed to accommodate both peak and root mean squared currents with sufficient margin and be qualified for isolation sufficient for automotive products. Then, shape and core types must be considered to optimize flux density. Finally, winding and termination structure must be chosen. Magnetics design is a complex and iterative process. It's common and recommended to work alongside an external vendor that can provide custom solutions.

The maximum input voltage must be considered when selecting the power device. For 400-V battery systems, a Silicon or Gallium Nitride FET can be used. For 800-V battery systems, Silicon Carbide (SiC) MOSFETs are becoming more popular due to their fast switching and high voltage rating (typically 900 V or greater). In either case having appropriate drive strength ensures reliability over lifetime.

The Silicon MOSFET driver integrated in the flyback controller may not be able to drive a SiC MOSFET directly. In these cases, external gate driver circuitry, or a low-side gate driver like the [UCC27531A-Q1](#), are recommended.

Careful consideration must be given to the UVLO turn-off threshold of the flyback controller. For SiC applications, a UVLO turn-off of greater than 8 V is recommended to provide increased lifetime reliability of the SiC MOSFET. Drive voltages less than 8 V can cause the power device to operate in the saturation region, which results in high conduction losses and heating. However, silicon MOSFETs can typically support drive voltages below 8 V.

## 3 Start-Up Circuitry

Standby power is a critical requirement in battery-operated systems. Resistive start-up circuitry causes high quiescent losses at high input voltages. Therefore, an external, active start-up circuit, or a device with integrated HV start-up such as the [UCC28730-Q1](#) or [UCC28740-Q1](#), is recommended.

[Figure 3-1](#) shows how an external, active start-up circuit can be implemented for a controller that utilizes resistive start-up, such as the [UCC28C56H-Q1](#).

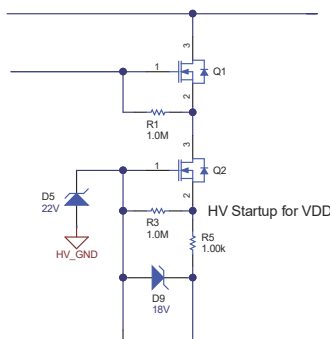

**Figure 3-1. Active Start-Up Circuit**

The [UCC28730-Q1](#) and [UCC28740-Q1](#) offer integrated 700-V start up, which enables operation directly off of a 400-V battery, but not an 800-V battery. As shown in [Figure 3-2](#), powering the start-up circuit from the center point of a stacked capacitor bank, or using a clamp circuit to clamp the voltage, enables operation directly off of an 800-V battery.

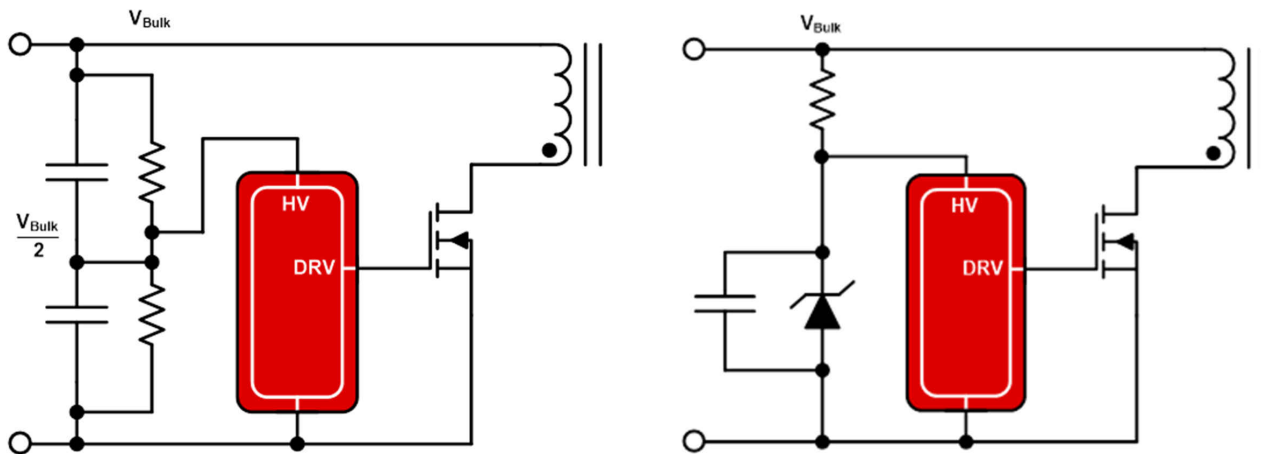

**Figure 3-2. Implementation to Support > 700 V Inputs**

The [UCC28700-Q1](#), and [UCC28730-Q1](#) and [UCC28740-Q1](#) variable frequency, peak current-mode flyback controllers and the [UCC28C56H-Q1](#) fixed-frequency, peak current-mode PWM controller offer a wide UVLO hysteresis that allows for more headroom on the VDD voltage before triggering UVLO, which provides long soft-start times and requires less capacitance on the VDD pin.

## 4 Noise Coupling

The high-voltage input and fast switching of the power device and related snubber can lead to a high dv/dt switching node, which generates a large amount of noise. Other sources of high di/dt loops or high dv/dt nodes in a HV DC-DC converter are gate drive, secondary-side rectifier, and transformer windings.

The voltage rating for the current sense pin must be considered when designing the backup flyback converter. A higher current sense (CS) voltage rating provides robustness against false CS pin triggering when operating across an ultra-wide input voltage range, and in a noisy environment.

The high dv/dt nodes must be kept small and away from quiet areas, such as the current sense circuitry, to reduce noise coupling. Poor layout can prevent the design from meeting the mechanical and electrical specifications needed to guarantee safe and predictable operation.

## 5 Safety

The distance between the high-voltage area at the primary side, and low-voltage area at the secondary side, must have enough clearance to comply with standards such as IEC 60664-1. The ground of the low-voltage side can be connected to a 12-V battery or vehicle chassis, which a user can come in contact with. Therefore, a transformer with reinforced isolation and AEC-Q200 Grade 1 compliance is recommended for this application.

The primary-side regulated flyback solutions, [UCC28700-Q1](#) and [UCC28730-Q1](#), do not require an optocoupler for feedback. This eliminates a component crossing the isolation barrier, and provides a more cost-effective solution. [UCC28C56H-Q1](#) can be configured as a primary-side regulated solution by using an auxiliary winding for feedback.

Not all system can be actively cooled through water or fans. So hot points like the transformer windings, power transistor, or rectification diodes can be managed using thermal vias, internal layers, and heatsinks.

## 6 Summary

When designing a HV-LV redundant flyback power supply, careful consideration is required for selecting high voltage automotive qualified devices, minimizing standby power losses and noise coupling, and ensuring the system meets safety requirements. For high-voltage power device selection, Silicon MOSFETs are typically acceptable for 400-V systems. However, Silicon Carbide MOSFETs are typically used in 800-V systems due to their higher voltage rating (typically 900 V or greater). External or internal start-up circuitry can be used to minimize standby power consumption. A high current sense voltage rating provides additional robustness against false CS pin triggering in a noisy environment. Primary-side regulated feedback does not require an optocoupler which increases system reliability and eliminates a component crossing the isolation barrier.

The evaluation module [UCC28c56EVM-066](#) shows a 40 V to 1 kV input HV to LV redundant power supply solution. The [UCC28781EVM-053](#) 50-500 V<sub>in</sub> flyback reference design also illustrates a potential solution for this application. [Table 7-1](#) covers the differences between TI's automotive flyback solutions.

## 7 Related Documentation

- Texas Instruments, [Why is High UVLO Important for Safe IGBT and SiC MOSFET Power Switch Operation?](#), application brief.

**Table 7-1. Flyback Controller Family Highlights**

Device	Regulation	Operation Mode	Control Law	Internal High-Voltage Start Up	UVLO On/Off Threshold (typ)	MAX Current Sense Threshold (typ)	Package
UCC28C56H-Q1	PSR or SSR <sup>(1)</sup> , <sup>(2)</sup>	DCM or CCM <sup>(3)</sup> , <sup>(4)</sup>	Fixed-Frequency PWM	No	14.5 V / 9 V	1 V	SOIC-8
UCC28700-Q1	PSR <sup>(1)</sup>	DCM <sup>(3)</sup>	AMFM <sup>(5)</sup>	No	21 V / 8 V	0.75 V	SOT23-6
UCC28730-Q1	PSR <sup>(1)</sup>	DCM <sup>(3)</sup>	AMFM <sup>(5)</sup>	Yes	21 V / 7 V	0.74 V	SOIC-7
UCC28740-Q1	SSR <sup>(2)</sup>	DCM <sup>(3)</sup>	AMFM <sup>(5)</sup>	Yes	21 V / 7.75 V	0.773 V	SOIC-7
UCC28781-Q1	SSR	TM	AMFM	No	17 V / 10.5 V	0.801 V	WQFN-24

- (1) PSR = Primary side regulation  
 (2) SSR = Secondary side regulation  
 (3) DCM = Discontinuous conduction mode  
 (4) CCM = Continuous conduction mode  
 (5) AMFM = Amplitude Modulation/Frequency Modulation

## 8 Revision History

---

<b>Changes from Revision B (October 2019) to Revision C (February 2023)</b>	<b>Page</b>
• Updated the numbering format for tables, figures, and cross-references throughout the document.....	1
• Updated <i>400 V battery</i> to <i>800 V</i> throughout the publication.....	1
• Added additional information regarding end equipment and references to the latest products and designs throughout the publication.....	1

---

## IMPORTANT NOTICE AND DISCLAIMER

TI PROVIDES TECHNICAL AND RELIABILITY DATA (INCLUDING DATA SHEETS), DESIGN RESOURCES (INCLUDING REFERENCE DESIGNS), APPLICATION OR OTHER DESIGN ADVICE, WEB TOOLS, SAFETY INFORMATION, AND OTHER RESOURCES "AS IS" AND WITH ALL FAULTS, AND DISCLAIMS ALL WARRANTIES, EXPRESS AND IMPLIED, INCLUDING WITHOUT LIMITATION ANY IMPLIED WARRANTIES OF MERCHANTABILITY, FITNESS FOR A PARTICULAR PURPOSE OR NON-INFRINGEMENT OF THIRD PARTY INTELLECTUAL PROPERTY RIGHTS.

These resources are intended for skilled developers designing with TI products. You are solely responsible for (1) selecting the appropriate TI products for your application, (2) designing, validating and testing your application, and (3) ensuring your application meets applicable standards, and any other safety, security, regulatory or other requirements.

These resources are subject to change without notice. TI grants you permission to use these resources only for development of an application that uses the TI products described in the resource. Other reproduction and display of these resources is prohibited. No license is granted to any other TI intellectual property right or to any third party intellectual property right. TI disclaims responsibility for, and you will fully indemnify TI and its representatives against, any claims, damages, costs, losses, and liabilities arising out of your use of these resources.

TI's products are provided subject to [TI's Terms of Sale](#) or other applicable terms available either on [ti.com](https://www.ti.com) or provided in conjunction with such TI products. TI's provision of these resources does not expand or otherwise alter TI's applicable warranties or warranty disclaimers for TI products.

TI objects to and rejects any additional or different terms you may have proposed.

Mailing Address: Texas Instruments, Post Office Box 655303, Dallas, Texas 75265  
Copyright © 2023, Texas Instruments Incorporated