

While similar to other robots currently in factory and service roles, humanoid robots are designed to mimic human movement with a high number of degrees of freedom (DOF) and fast response time (in milliseconds) to the surrounding environment. This creates a challenge for robotic system engineers as they solve key power-related design challenges in the many motors throughout these robots, as shown in [Figure 1](#).

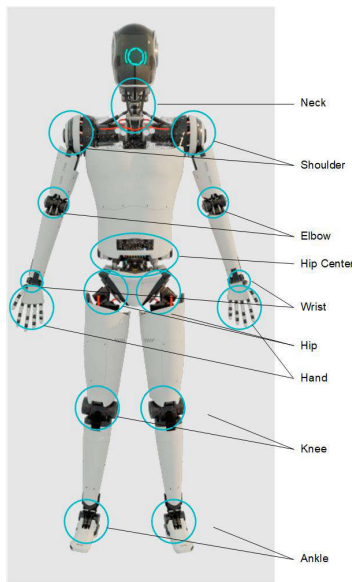

Figure 1. Showing Locations of DOF in Humanoid Robots

The DOF shown in [Figure 1](#) have different power requirements based on the amount of load the motor needs to move the power level, which typically varies between 10W to 4kW with the majority of the drives between 10W and 1.5kW.

The typical power requirements can be categorized into the following options:

- 10W to 100W: Wrist and hand
- 100W to 300W: Ankle, shoulder, neck
- 1kW to 1.9kW: Elbow 1.5kW
- 2.5kW to 4kW: Knee, hip, hip center

These categories have different requirements for motor size and thermal performance that need to be considered when selecting components. Motor type is another consideration with selection based on power level and efficiency requirements.

For example, when designing with permanent magnet synchronous motors (PMSM), engineers can choose from trapezoidal or sinusoidal control topologies. Typically sinusoidal control is selected due to how the winding and control algorithm affects how precise the motor can be controlled.

The humanoid battery is typically built to work within the SELV voltage range, which is below 60V. This means that the components need to be operational up to 60V, there is even a preference to be to be operational up to 100V to reduce effects of potential noise in the system for the FETs, and gate drivers.

Using higher switching frequencies to reduce torque ripple effects of the drive enables more precise torque control for the motion controller, helping improve performance of the drive. To enable this, higher switching frequencies in high-performance MosFETs or GaN FETs are required to implement the drive and therefore help increase motor efficiency. GaN FETs have lower switching energy due to low FET capacitance and no body diode. This gives them the advantage of lower switching losses at higher switching frequencies. Sophisticated algorithms can also help reduce the switching requirements and losses of the motors FETs.

High-power density in motor drives is an important consideration due to the temperature limitations of robots where the exterior of the robot is not allowed to be higher than 55°C, as this temperature can cause full-thickness skin burn in around 10 seconds. Contact such as this can happen very quickly for a robot working in close proximity to humans. With the size and weight requirements of humanoid robots, the temperature management design cannot accommodate fans or liquids. Since active cooling is not an option for thermal management, that means the robot must produce less power losses to maintain a lower temperature.

Functional safety is another crucial consideration when designing humanoid robots. Currently there are no standards that define the functional safety requirements of humanoid robots, though there are standards for cobots and industrial robots. However, there are study groups around the world that are analyzing humanoid robots to develop safety requirements in the future for them. Until safety requirements are defined, humanoid designers must conduct due diligence of current system designs to minimize redesign efforts in the future. Right now, taking note of the ISO13482, ISO10218 and the ISO 3691-4 can give some insight to what to expect in the future. This topic is a generic topic which is the same for all motor drive classes and is discussed in a separate chapter.

10W to 100W: Wrist and Hand

The wrist and hand system of a humanoid robot typically requires eight or more motors per hand to match the key movements of the hand and wrist. With this large number of motors in such a small space, size is a premium. Using higher levels of integration in the ICs on the board can help reduce the size of the total design.

During design, consideration is needed for how to split this system into blocks that benefit from integration and size optimize the design the best. A typical approach for the motor drive is to integrate FETs, gate driver, and current sensing for all three phases in one device. This device connects to a motor controller which can receive the signals from the integrated motor and communicate with the robot controller.

TI has a large portfolio of motor drives and integrated GaN half-bridges. Many of these devices offer the high level of integration which fits and is required to enable designers to build these highly compact systems.

Silicon FET: Gate Driver Integrated

High levels of device integration and potential space savings are key design considerations when selecting BLDC motor drivers. DC bus voltage for the wrist to hand vary from the other portions of humanoid robots. Voltage rail can range from 24V to 48V depending on the implementation. The recommendation when selecting a BLDC driver is to choose one that has an absolute maximum voltage that is 1.5 to two times the operating voltage. To accommodate for designs that require 24V, the [DRV8316C](#) is the recommended device to use. [DRV8316C](#) is a 40V, 8A peak rated 3-phase motor driver that integrates the FETs and three CSAs. The RDS(ON) high side plus low side is 95mΩ, making it robust to higher current and manage thermals in the system appropriately. This device has an integrated buck converter and LDO and SPI and hardware interface available in a 7x5mm QFN package. For 36 to 48V operation, [DRV8376](#) is a new addition to the integrated FET BLDC family. It is a 70V, 4A peak rated 3-phase motor driver with integrated FETs and 3 CSAs. The RDS(ON) high side plus low side is 400mΩ. [DRV8376](#) has adjustable output voltage slew rate at 1.1V/ns reducing the switching losses. For low audible noise and simple motor control, [DRV8376](#) has ultra-low deadtime less than 200ns and propagation delay less than 100ns. SPI and hardware interfaces are available for the device in a small 6x5mm QFN package. For integrated FET motor drivers, thermal calculators are available to determine the power capability of the device based on the system requirements. Typical operation for [DRV8316C](#) is 80W and for [DRV8376](#), 50W. These values can vary for specific system implementation.

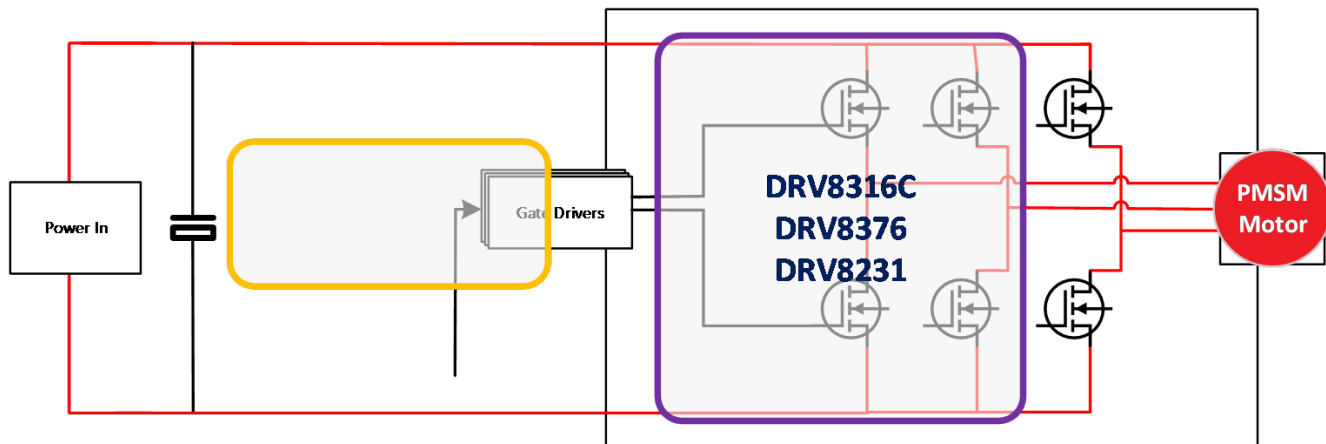

Figure 2. Gate Driver Block Diagram

100W to 300W: Ankle, Shoulder, Neck

Due to the location of these systems more space is available, which leaves more options of how to design the drives in this category.

When designing these drives the customer needs to pick motor drives which can both achieve the power requirement and the size constraint. Here both solutions using gate drivers with integrated FETs and options with external FETs can be implemented as the size here is not as critical, however thermal considerations must be made to verify the overall temperature of the robot is kept low enough.

Silicon FET: Gate Driver

With higher power needed for ankles, shoulders, and neck, a gate driver is typically used when designing. This gives engineers flexibility to swap FETs for even higher power requirements while keeping the same gate driver design. For this power and higher 48V rail is used for these joints. [DRV8300](#), [DRV835xF](#), and [DRV8162](#) are recommended devices for this voltage and power level. [DRV8300](#) is a simple 100V, 3-phase gate driver with minimal integration. The key use case for this device is for cost sensitive and space constrained systems. There are many variants of package from TSSOP to QFN including a bootstrap diode or optionally implementing externally. [DRV8353F](#) is a high integration 100V capable device with a Functional Safety Quality Managed Certification and three integrated CSAs. In many robotics environments the need for safety is key when interacting with humans. [DRV8353F](#) has documentation to aid IEC 61800-5-2 functional safety system design. [DRV8162](#) is a smart single-half bridge gate driver that implements the same safety considerations as

the DRV8353F. Read more about the DRV8162 for robotics applications in [Cobots to humanoid: Driving system efficiency and safety into higher-power robots](#)

GaN FET: Power Stage

GaN devices are also being used increasingly in humanoid robots to meet thermal requirements and space constraints. The [LMG2100R044](#) is a 100V, 4.4mΩ half-bridge and driver with integrated bootstrap diode. This device comes in a 4.5 × 5.5mm QFN package and can power a 3-phase inverter up to 16A without a heat sink. See [GaN 3-Phase Inverter design guide](#) for more information.

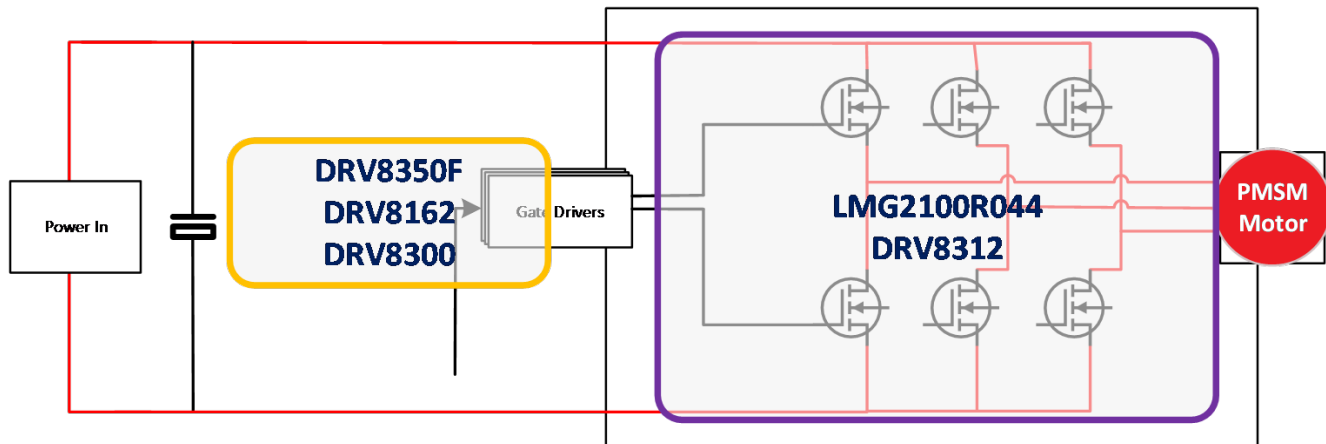

Figure 3. Gate Driver Block Diagram

1kW to 1.9kW: Elbow

Both functional safety and higher power are design considerations for humanoid robot elbow motor drive designs. Here the thermal performance and efficiency of the drive is critical due to the higher mechanical weight of the joints, so the designer must develop a design with high power density.

Improving the torque and current ripple of the drive by increasing the used frequency of the motor driver is one part of achieving higher efficiency.

Options such as GaN FETs can be considered because the FETs have lower losses and a smaller sized design.

Figure 4 shows the power stage block diagram.

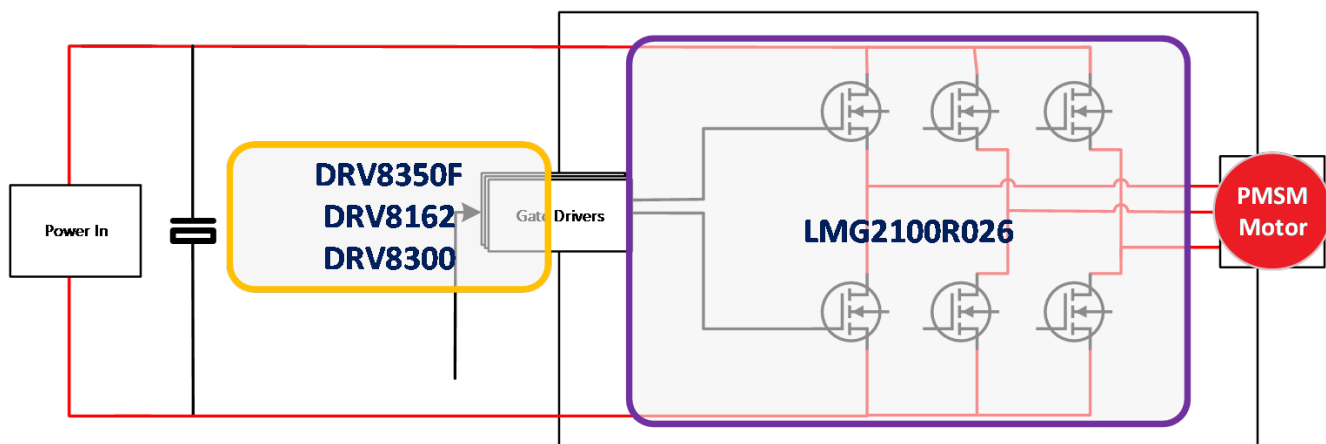

Figure 4. Power Stage Block Diagram

BLDC: Gate Driver

See [100W to 300W: Ankle, Shoulder, Neck](#) for more information.

GaN FET: Power Stage

For elbow joints, the [LMG2100R026](#) provides power density while minimizing losses to meet thermal requirements. The LMG2100R026 is available in a 4.5 × 7mm QFN package including a gate driver, bootstrap diode, and 2.6mΩ GaN half-bridge. This device can be evaluated using the [BOOSTXL-LMG2100-MD](#).

2.5kW to 4kW: Knee, Hip, Hip Center

This category of motors has the highest power requirement in the robot and the power density of this design is crucial to its functionality. In these motors high efficiency and small size are key design concerns. Typically paralleling of FETs is required to build a system design. This means additional requirements to the gate driver of current capability to enable fast switching to improve the overall efficiency of the system.

The fast switching time also enable higher PWM frequencies which improve the torque and current ripple of the system.

BLDC: Gate Driver

For 2.5-4kW applications in the knee and hip DRV8162 is the key device to implement.

See [Cobots to Humanoids: Driving system efficiency and safety into higher-power robots](#) to learn more.

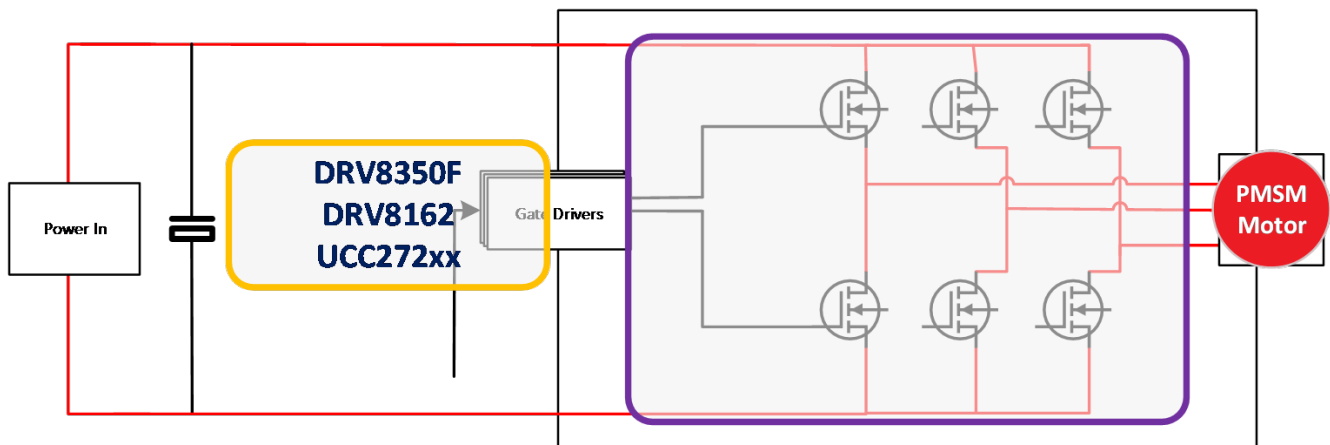

Figure 5. BLDC Gate Driver Diagram

There are many different situations which designers needs to analyze and define the requirements to optimize the motor drive systems for the humanoid robot. TI has designs which can solve all four categories of designs to enable designers to build humanoid robots.

Functional Safety

When planning for future designs, it is important to select devices that help simplify functional safety certification. Standards such as ISO13482, ISO10218, and the ISO 3691-4 provide insights to what to expect in the future for humanoid safety requirements. Both class C standards (ISO10218 and ISO3691-4) refer to ISO13849 stating that the system needs to be PLd, however, the ISO3691-4 leaves the architecture up to the implementer and the ISO10218 mandates a CAT3 architecture. Considering the worst-case scenario from these standards at least CAT3 PLd safety considerations must be taken for a humanoid robot. The safety architecture shown in needs to implement a CAT3 system.

To enable safety on a motor drive typically the standard IEC61800-5-2 or the standard IEC60204-1 using a STO or category 0,1,2 type function is being implemented to enable the safe stop function, this stop function is heavily dependent on the gate driver and how to disable the gate driver function. TI is working with TÜV SÜD to document concepts showing how to use TI gate drivers for this type of safety function. See [Design Smaller Safe Torque Off \(STO\) Systems Using Integrated 3-Phase Smart Gate Drivers](#) for more details.

TI offers many devices with extensive safety documentation to enable customers to build safety designs, see .

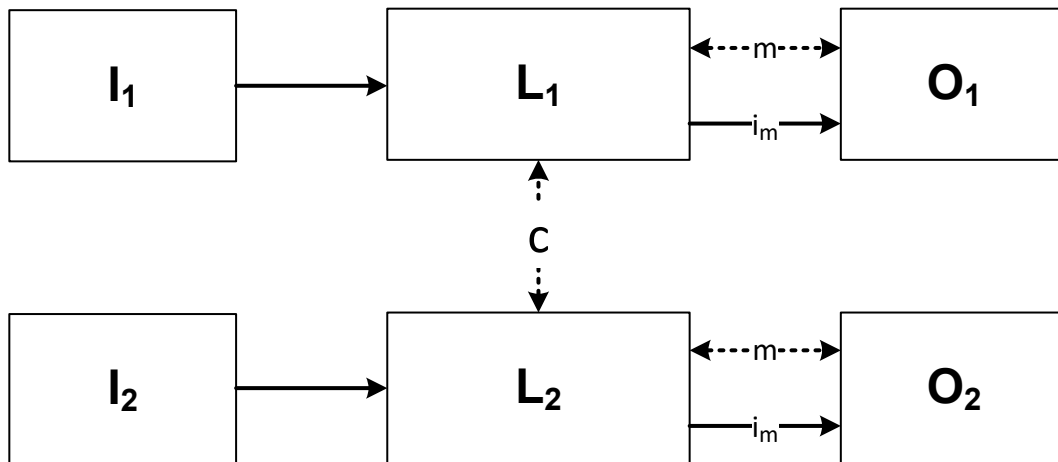

Key	Illustration from IEC13849-1:2023 figure 10
i_m	Interconnecting means
c	Cross Monitoring
I_1, I_2	Input device
L_1, L_2	Logic
m	Monitoring
O_1, O_2	Output device
Dashed lines represent reasonably practicable fault detection	

Figure 6. Illustration from IEC13849-1:2015

Conclusion

When designing humanoid robot motor drivers, there are many types of drives with each type having different design specifications based on the function in the bot. TI has a broad portfolio of integrated circuits which enable customers to realize the different design specifications to build robots which can quickly react in the environment. [Figure 7](#) shows a block diagram of a 1kW to 1.9kW motor drive system which features multiple TI products.

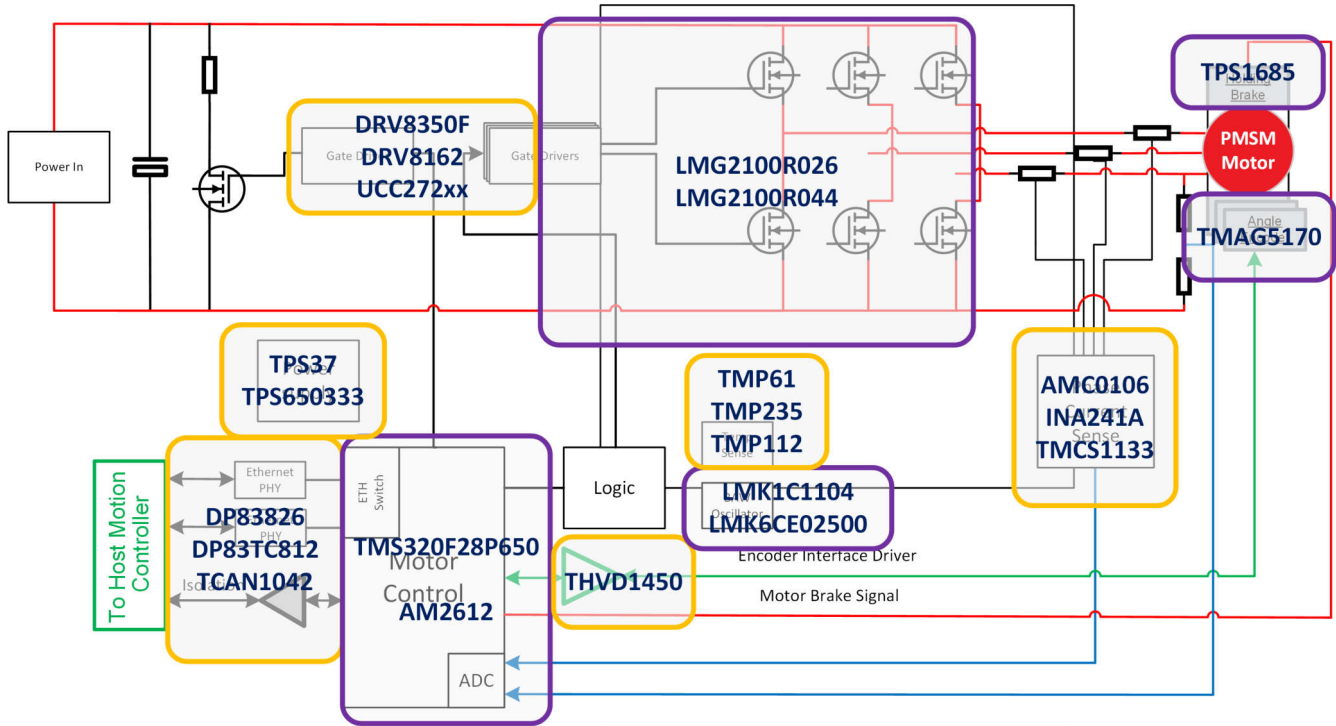

Figure 7. 1kW to 1.9kW System Block Diagram

TI offers several of evaluation modules and reference designs to help engineers evaluate system designs faster and streamline the process of building a production-ready design. TI also helps designers simplify and accelerate the functional safety system design process with functional safety products and design tools.

Trademarks

All trademarks are the property of their respective owners.

IMPORTANT NOTICE AND DISCLAIMER

TI PROVIDES TECHNICAL AND RELIABILITY DATA (INCLUDING DATASHEETS), DESIGN RESOURCES (INCLUDING REFERENCE DESIGNS), APPLICATION OR OTHER DESIGN ADVICE, WEB TOOLS, SAFETY INFORMATION, AND OTHER RESOURCES "AS IS" AND WITH ALL FAULTS, AND DISCLAIMS ALL WARRANTIES, EXPRESS AND IMPLIED, INCLUDING WITHOUT LIMITATION ANY IMPLIED WARRANTIES OF MERCHANTABILITY, FITNESS FOR A PARTICULAR PURPOSE OR NON-INFRINGEMENT OF THIRD PARTY INTELLECTUAL PROPERTY RIGHTS.

These resources are intended for skilled developers designing with TI products. You are solely responsible for (1) selecting the appropriate TI products for your application, (2) designing, validating and testing your application, and (3) ensuring your application meets applicable standards, and any other safety, security, regulatory or other requirements.

These resources are subject to change without notice. TI grants you permission to use these resources only for development of an application that uses the TI products described in the resource. Other reproduction and display of these resources is prohibited. No license is granted to any other TI intellectual property right or to any third party intellectual property right. TI disclaims responsibility for, and you fully indemnify TI and its representatives against any claims, damages, costs, losses, and liabilities arising out of your use of these resources.

TI's products are provided subject to [TI's Terms of Sale](#), [TI's General Quality Guidelines](#), or other applicable terms available either on ti.com or provided in conjunction with such TI products. TI's provision of these resources does not expand or otherwise alter TI's applicable warranties or warranty disclaimers for TI products. Unless TI explicitly designates a product as custom or customer-specified, TI products are standard, catalog, general purpose devices.

TI objects to and rejects any additional or different terms you may propose.

Copyright © 2026, Texas Instruments Incorporated

Last updated 10/2025