

User's Guide

MCT8316AT Tuning guide



ABSTRACT

This Tuning guide provides step by step guidance to setup MCx8316AEVM and tune a 3-phase Brushless DC motor using [MCT8316AT](#).

Table of Contents

1 Introduction	2
1.1 Hardware Setup.....	3
2 Quick Tuning	5
3 Comprehensive Tuning	7
3.1 Cycle by cycle current limit.....	7
3.2 Motor Startup Settings.....	7
3.3 Abnormal Speed Threshold.....	11
3.4 PWM Switching Frequency.....	12
3.5 Lead Angle.....	12
3.6 Slew Rate and Buck Voltage.....	13
4 Revision History	13

List of Figures

Figure 1-1. MCT8316AT Simplified Schematic.....	2
Figure 1-2. MCx8316A EVM Jumper Configuration.....	3
Figure 1-3. MCx8316A EVM External Configuration.....	4

List of Tables

Table 2-1. Recommended Resistor Values.....	5
Table 2-2. Default Parameters.....	6
Table 3-1. ILIMIT Pin Resistor Values.....	7
Table 3-2. End Equipment Example for Motor Startup Profile.....	8
Table 3-3. Default Motor Startup Parameters for Ultra-High Inertia.....	8
Table 3-4. Default Motor Startup Parameters for Very High Inertia.....	8
Table 3-5. Default Motor Startup Parameters for High Inertia.....	8
Table 3-6. Default Motor Startup Parameters for Low Acceleration.....	9
Table 3-7. Default Motor Startup Parameters for Medium Acceleration.....	9
Table 3-8. Default Motor Startup Parameters for High Acceleration.....	9
Table 3-9. Default Motor Startup Parameters for Very High Acceleration.....	10
Table 3-10. Default Motor Startup Parameters for Ultra-High Acceleration.....	10
Table 3-11. RMP_1 Pin Resistor Values.....	11
Table 3-12. RMP_2 Pin Resistor Values.....	11
Table 3-13. CONFIG_3 Pin Resistor Values.....	11
Table 3-14. CONFIG_1 pin resistor values.....	12
Table 3-15. LDANGLE pin resistor values.....	12
Table 3-16. SLEW_RATE pin resistor values.....	13

Trademarks

All trademarks are the property of their respective owners.

1 Introduction

The MCT8316AT provides three half-H-bridge integrated MOSFET drivers with sensorless trapezoidal control to drive a three-phase brushless DC (BLDC) motor at 12-V/24-V DC rails or battery powered applications. The device integrates three current-sense amplifiers (CSA) with integrated current sense for sensing the three phase currents of BLDC motors to achieve optimum trapezoidal control. Simplified schematic of MCT8316AT is shown in Figure 1-1.

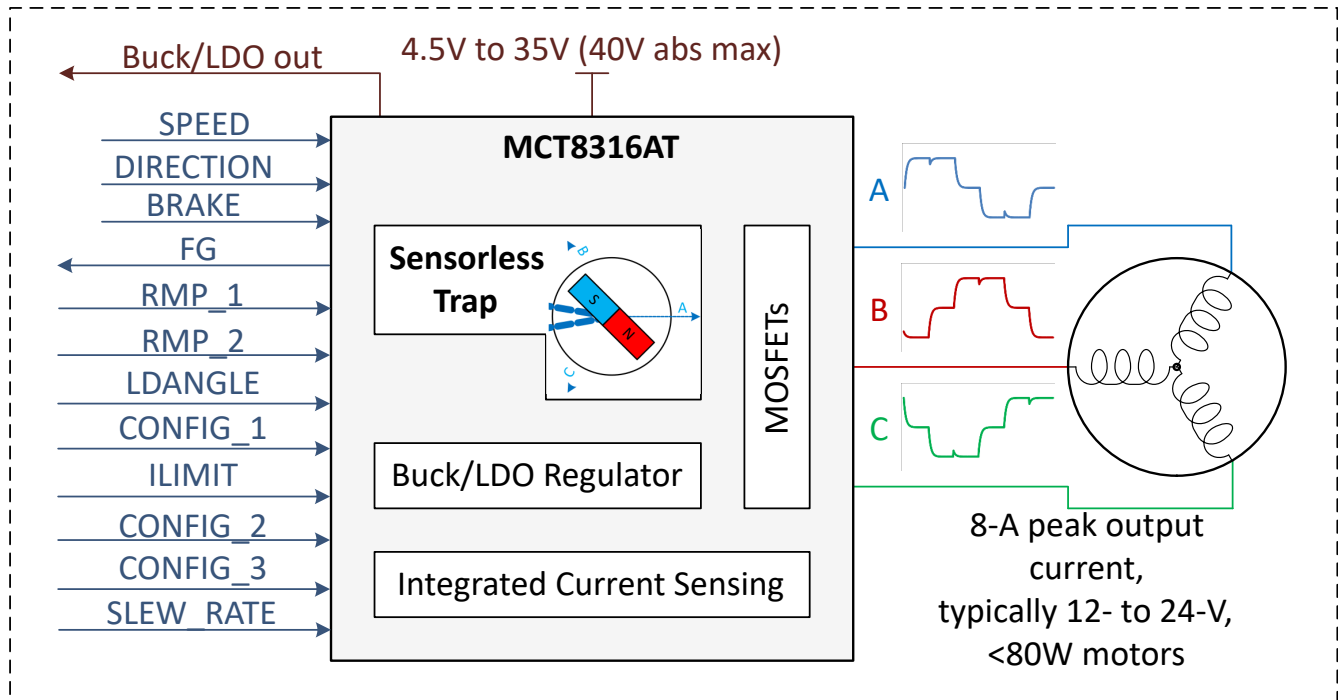

Figure 1-1. MCT8316AT Simplified Schematic

This tuning guide provides the steps to tune a 3-phase BLDC motor using the MCT8316AT. The tuning process is classified into two sections: Quick tuning and Comprehensive tuning. This process is also detailed in the Guided tuning section in the GUI.

- **Quick tuning:** The goal of quick tuning is to get the motor running quickly by providing default resistor values for RMP_1, RMP_2, LDANGLE, CONFIG_1, ILIMIT, CONFIG_2, CONFIG_3 and SLEW_RATE pins of MCT8316AT.
- **Comprehensive tuning:** The comprehensive tuning section provides a simplified methodology for tuning critical device parameters such as Motor startup profile, motor startup method, lead angle, PWM switching frequency, Cycle by cycle current limit, abnormal speed threshold, slew rate and Buck voltage.

1.1 Hardware Setup

1.1.1 Jumper Configuration

Ensure the hardware is configured according to the jumper configuration as shown in Figure 1-2. Red boxes indicate where jumpers should be installed on the EVM.

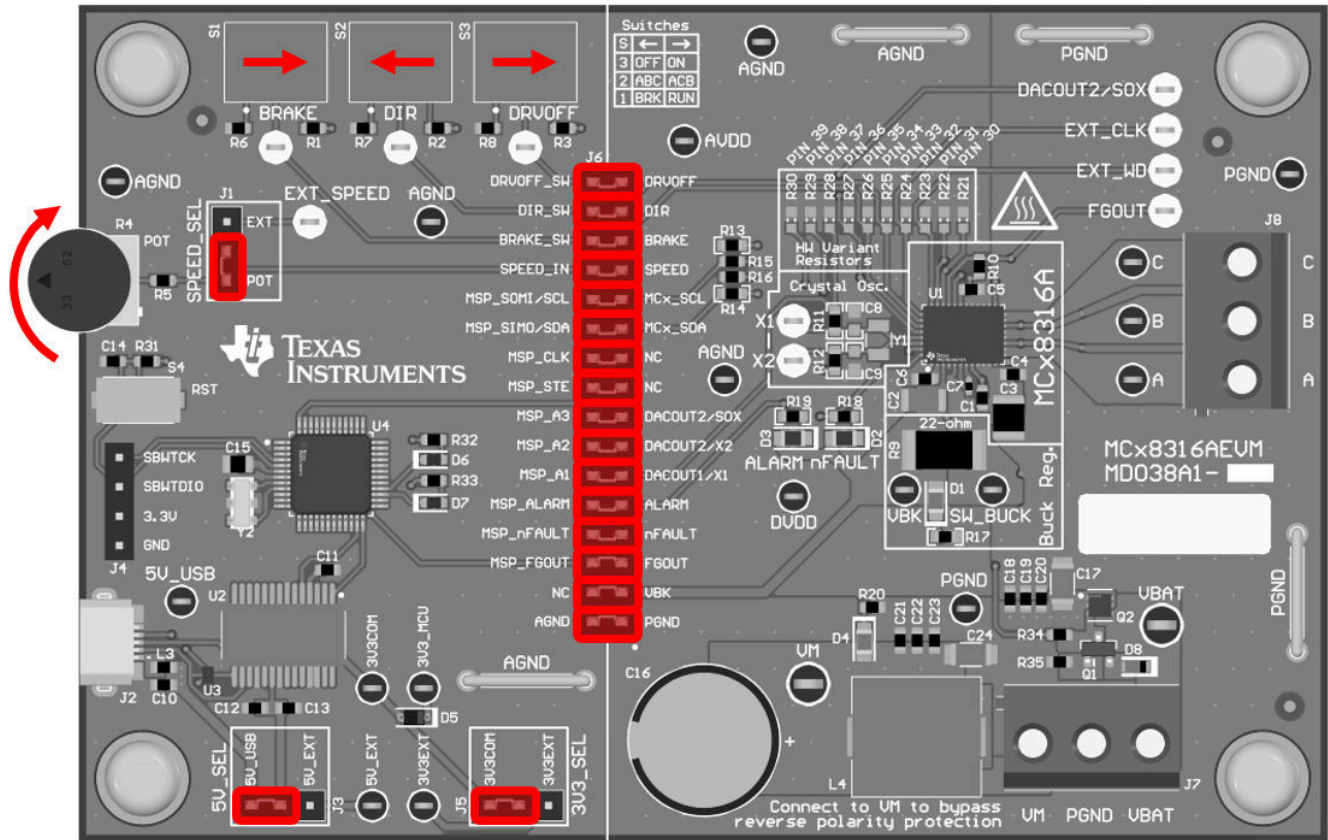

Figure 1-2. MCx8316A EVM Jumper Configuration

Note

Depopulate resistors R15 and R16 if they are populated on the MCx8316AEVM.

1.1.2 External Connections

Connect the motor to J8 (connections A, B, and C). If the motor has a center tap connection or wires for Hall-effect sensors, leave these wires unconnected. Supply a voltage compliant with the Power Supply Voltage (VM) range using J7. Recommended voltage range for the device is 4.5 V – 35 V.

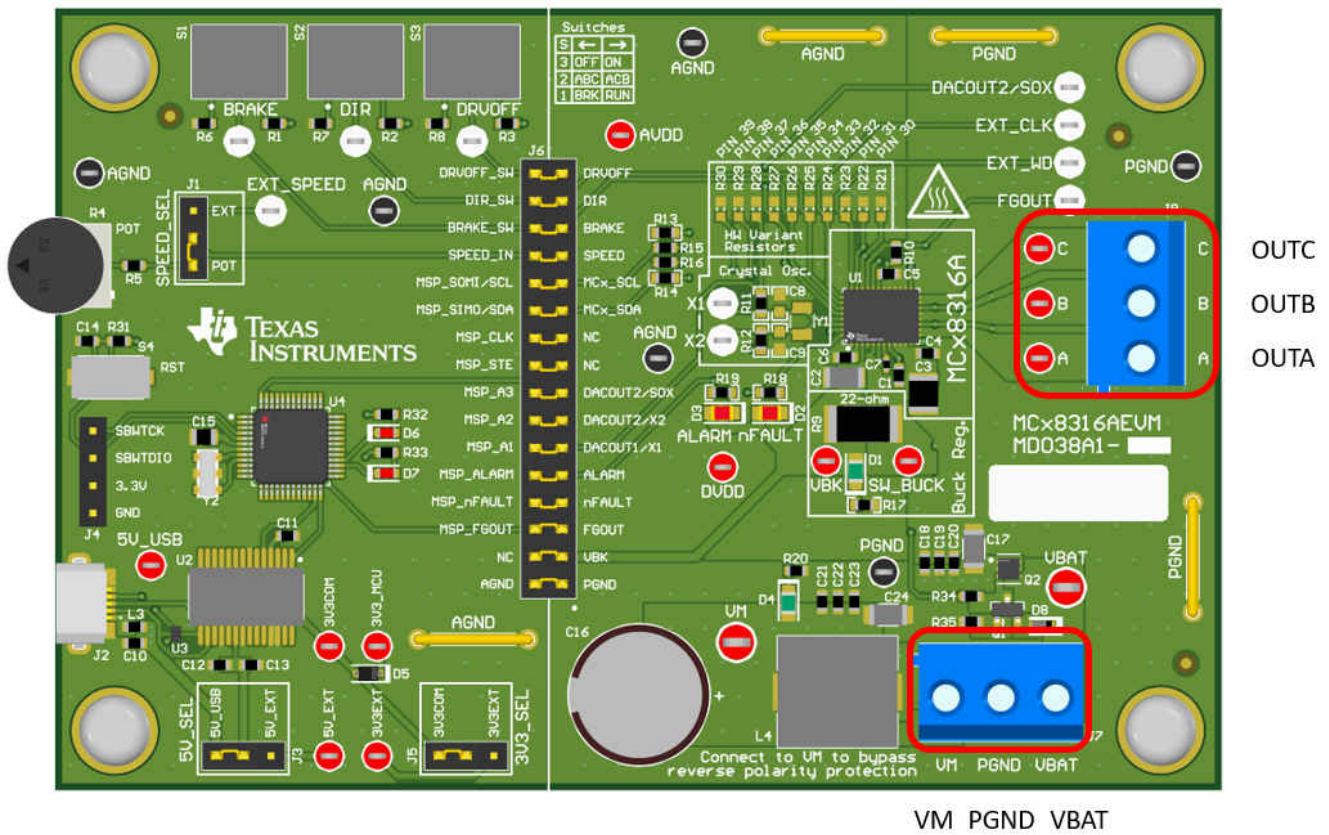

Figure 1-3. MCx8316A EVM External Configuration

2 Quick Tuning

The goal of quick tuning is to get the motor running quickly by populating the recommended resistor values shown in [Table 2-1](#).

Table 2-1. Recommended Resistor Values

Pin number	Pin name	Resistor value
30	RMP_1	22 k Ω , \pm 5%
31	RMP_2	Tie to GND
32	LDANGLE	Tie to GND
33	CONFIG_1	62 k Ω , \pm 5%
36	ILIMIT	51 k Ω , \pm 5%
37	CONFIG_2	75 k Ω , \pm 5%
38	CONFIG_3	200 k Ω , \pm 5%
39	SLEW_RATE	10 k Ω , \pm 5%

[Table 2-2](#) shows the default parameter values based on the recommended default resistor values shown in [Table 2-1](#).

Table 2-2. Default Parameters

Parameter	Value	Unit
Startup profile	Medium acceleration	-
Motor startup method (MTR_STARTUP)	Double align	-
Align ramp rate (ALIGN_RAMP_RATE)	500	V/s
Closed loop acceleration (CL_ACC)	75	V/s
Open loop duty cycle (OL_DUTY)	25	%
Open loop acceleration (OL_ACC_A1)	25	Hz/s
Startup brake time (STARTUP_BRK_TIME)	100	ms
Slow first cycle frequency (SLOW_FIRST_CYC_FREQ)	0.5	Hz
Dynamic degauss (DYN_DEGAUSS_EN)	Disabled	-
Align time (ALIGN_TIME)	750	ms
Lead angle (LD_ANGLE)	0	deg
BEMF threshold (BEMF_THRESHOLD)	700	-
IPD Clock frequency (IPD_CLK_FREQ)	2000	Hz
PWM output frequency (PWM_FREQ_OUT)	50	kHz
ZC detection blanking time (TBLANK)	6	μs
Open loop current (OL_ILIMIT)	3.33	A
Align current threshold (ALIGN_CURR_THR)	3.33	A
IPD current threshold (IPD_CURR_THR)	3.33	A
CSA gain (CSA_GAIN)	0.15	V/A
CBC current limit (ILIMIT)	4.67	A
Slew rate (SLEW_RATE)	50	V/μs
Buck voltage output (BUCK_SEL)	3.3	V
OCP mode (OCP_MODE)	Retry after 500 ms	-
ASR (EN_ASR)	Disabled	-
Delay compensation (DELAY_COMP_EN)	Disabled	-
OCP level (OCP_LVL)	15	A
Abnormal speed (ABN_SPEED)	4000	Hz
Minimum duty (MIN_DUTY)	5	%

3 Comprehensive Tuning

The comprehensive tuning section provides a simplified methodology for tuning critical parameters and selecting the appropriate resistors for the following pins in MCT8316AT.

- RMP_1
- RMP_2
- LDANGLE
- CONFIG_1
- ILIMIT
- CONFIG_3
- SLEW_RATE

Note

Resistor value for CONFIG_2 pin is defaulted to 75 k Ω , $\pm 5\%$.

Testing is required to find the optimal resistor value for the motor. This includes replacing the resistors on the MCT8316AT pins, as necessary.

3.1 Cycle by cycle current limit

Cycle by cycle current limit provides a means of controlling the amount of current delivered to the motor. This is useful when the system must limit the amount of current pulled from the power supply during motor start-up. The cycle by cycle current-limit limits the current applied to the motor from exceeding the configured threshold. Configure Cycle by cycle current limit to the rated peak phase current of the motor. Check the motor datasheet for the rated peak phase current in Amps.

3.1.1 Selecting ILIMIT Pin Resistor

Refer to [Table 3-1](#) to select the appropriate ILIMIT resistor value based on the CBC current limit.

Table 3-1. ILIMIT Pin Resistor Values

CBC current limit (A)	ILIMIT pin resistor value
0.5	Tie to GND
1	4.7 k Ω , $\pm 5\%$
1.33	10 k Ω , $\pm 5\%$
2.67	15 k Ω , $\pm 5\%$
3.33	22 k Ω , $\pm 5\%$
4	30 k Ω , $\pm 5\%$
4.67	51 k Ω , $\pm 5\%$
5.33	62 k Ω , $\pm 5\%$
6	91 k Ω , $\pm 5\%$
7.33	200 k Ω , $\pm 5\%$
8	300 k Ω , $\pm 5\%$

3.2 Motor Startup Settings

Motor startup settings include choosing the motor startup profile and motor startup method.

3.2.1 Motor Startup Profile

Motor startup profile is chosen based on the inertia profile of the motor-load system. Inertia profiles range from ultra-high inertia to ultra-high acceleration. [Table 3-2](#) provides the end equipment examples for all the motor startup profile. Select the appropriate motor startup profile that closely matches to your application.

Table 3-2. End Equipment Example for Motor Startup Profile

Motor startup profile	End equipment
Ultra-high inertia	Ceiling fan
Very high inertia	Pedestal fan
High inertia	Blowers
Low acceleration	
Medium acceleration	Appliances pumps
High acceleration	Robotic vacuum suction motor
Very high acceleration	
Ultra-high acceleration	Fuel pumps

Table 3-3 shows the default motor startup parameters for ultra-high inertia.

Table 3-3. Default Motor Startup Parameters for Ultra-High Inertia

Parameter	Value	Unit
Align ramp rate (ALIGN_RAMP_RATE)	10	V/s
Closed loop acceleration (CL_ACC)	1	V/s
Open loop duty cycle (OL_DUTY)	15	%
Open loop acceleration (OL_ACC_A1)	0.005	Hz/s
Startup brake time (STARTUP_BRK_TIME)	5000	ms
Slow first cycle frequency (SLOW_FIRST_CYC_FREQ)	0.01	Hz
Align time (ALIGN_TIME)	6000	ms
Dynamic degauss (DYN_DEGAUSS_EN)	Disabled	-

Table 3-4 shows the default motor startup parameters for very-high inertia.

Table 3-4. Default Motor Startup Parameters for Very High Inertia

Parameter	Value	Unit
Align ramp rate (ALIGN_RAMP_RATE)	10	V/s
Closed loop acceleration (CL_ACC)	5	V/s
Open loop duty cycle (OL_DUTY)	15	%
Open loop acceleration (OL_ACC_A1)	0.05	Hz/s
Startup brake time (STARTUP_BRK_TIME)	1000	ms
Slow first cycle frequency (SLOW_FIRST_CYC_FREQ)	0.05	Hz
Align time (ALIGN_TIME)	4000	ms
Dynamic degauss (DYN_DEGAUSS_EN)	Disabled	-

Table 3-5 shows the default motor startup parameters for high inertia.

Table 3-5. Default Motor Startup Parameters for High Inertia

Parameter	Value	Unit
Align ramp rate (ALIGN_RAMP_RATE)	100	V/s
Closed loop acceleration (CL_ACC)	15	V/s
Open loop duty cycle (OL_DUTY)	20	%
Open loop acceleration (OL_ACC_A1)	1	Hz/s

Table 3-5. Default Motor Startup Parameters for High Inertia (continued)

Parameter	Value	Unit
Startup brake time (STARTUP_BRK_TIME)	500	ms
Slow first cycle frequency (SLOW_FIRST_CYC_FREQ)	0.25	Hz
Align time (ALIGN_TIME)	2000	ms
Dynamic degauss (DYN_DEGAUSS_EN)	Disabled	-

Table 3-6 shows the default motor startup parameters for low acceleration.

Table 3-6. Default Motor Startup Parameters for Low Acceleration

Parameter	Value	Unit
Align ramp rate (ALIGN_RAMP_RATE)	100	V/s
Closed loop acceleration (CL_ACC)	25	V/s
Open loop duty cycle (OL_DUTY)	20	%
Open loop acceleration (OL_ACC_A1)	1	Hz/s
Startup brake time (STARTUP_BRK_TIME)	500	ms
Slow first cycle frequency (SLOW_FIRST_CYC_FREQ)	0.25	Hz
Align time (ALIGN_TIME)	2000	ms
Dynamic degauss (DYN_DEGAUSS_EN)	Disabled	-

Table 3-7 shows the default motor startup parameters for medium acceleration.

Table 3-7. Default Motor Startup Parameters for Medium Acceleration

Parameter	Value	Unit
Align ramp rate (ALIGN_RAMP_RATE)	500	V/s
Closed loop acceleration (CL_ACC)	75	V/s
Open loop duty cycle (OL_DUTY)	25	%
Open loop acceleration (OL_ACC_A1)	25	Hz/s
Startup brake time (STARTUP_BRK_TIME)	100	ms
Slow first cycle frequency (SLOW_FIRST_CYC_FREQ)	0.5	Hz
Align time (ALIGN_TIME)	500	ms
Dynamic degauss (DYN_DEGAUSS_EN)	Enabled	-

Table 3-8 shows the default motor startup parameters for high acceleration.

Table 3-8. Default Motor Startup Parameters for High Acceleration

Parameter	Value	Unit
Align ramp rate (ALIGN_RAMP_RATE)	500	V/s
Closed loop acceleration (CL_ACC)	150	V/s
Open loop duty cycle (OL_DUTY)	25	%
Open loop acceleration (OL_ACC_A1)	100	Hz/s
Startup brake time (STARTUP_BRK_TIME)	75	ms
Slow first cycle frequency (SLOW_FIRST_CYC_FREQ)	0.5	Hz
Align time (ALIGN_TIME)	300	ms

Table 3-8. Default Motor Startup Parameters for High Acceleration (continued)

Parameter	Value	Unit
Dynamic degauss (DYN_DEGAUSS_EN)	Enabled	-

Table 3-9 shows the default motor startup parameters for very high acceleration.

Table 3-9. Default Motor Startup Parameters for Very High Acceleration

Parameter	Value	Unit
Align ramp rate (ALIGN_RAMP_RATE)	1000	V/s
Closed loop acceleration (CL_ACC)	250	V/s
Open loop duty cycle (OL_DUTY)	40	%
Open loop acceleration (OL_ACC_A1)	200	Hz/s
Startup brake time (STARTUP_BRK_TIME)	50	ms
Slow first cycle frequency (SLOW_FIRST_CYC_FREQ)	1	Hz
Align time (ALIGN_TIME)	100	ms
Dynamic degauss (DYN_DEGAUSS_EN)	Enabled	-

Table 3-10 shows the default motor startup parameters for ultra-high acceleration.

Table 3-10. Default Motor Startup Parameters for Ultra-High Acceleration

Parameter	Value	Unit
Align ramp rate (ALIGN_RAMP_RATE)	1000	V/s
Closed loop acceleration (CL_ACC)	1000	V/s
Open loop duty cycle (OL_DUTY)	40	%
Open loop acceleration (OL_ACC_A1)	1000	Hz/s
Startup brake time (STARTUP_BRK_TIME)	10	ms
Slow first cycle frequency (SLOW_FIRST_CYC_FREQ)	15	Hz
Align time (ALIGN_TIME)	25	ms
Dynamic degauss (DYN_DEGAUSS_EN)	Enabled	-

3.2.2 Motor startup method

MCT8316AT provides two motor startup methods.

3.2.2.1 Initial Position detect (IPD)

Initial Position Detection algorithm (IPD) function can be selected as motor startup method in applications where reverse spin is not acceptable. While this function is suitable for motors with high inertia, such as heavy blades (for example: a ceiling or appliance fan), it is not suitable for motors with low inertia, such as small blades (for example: a computer fan), because the current injection will cause the motor to shake, resulting in the IPD not being accurate.

3.2.2.2 Double align

Double align can be selected as the startup method when the motor does not have sufficient saliency to detect position using IPD. Also, in applications where the acoustic noise (“chirp”) generated by IPD is not acceptable during startup, it is recommended to select double align as the startup method.

3.2.3 Selecting RMP_1 and RMP_2 Pin Resistors

Select the appropriate RMP_1 and RMP_2 resistors using [Table 3-11](#) and [Table 3-12](#) based on the selected motor startup profile and motor startup method in [Section 3.2.1](#) and [Section 3.2.2](#).

Table 3-11. RMP_1 Pin Resistor Values

Pin	Motor Startup Profile	Startup Method	Resistor Value
RMP_1	Ultra-high inertia	Double align	Tied to GND
		IPD	62 k Ω , \pm 5%
	Very high inertia	Double align	4.7 k Ω , \pm 5%
		IPD	75 k Ω , \pm 5%
	High inertia	Double align	10 k Ω , \pm 5%
		IPD	91 k Ω , \pm 5%
	Low acceleration	Double align	15 k Ω , \pm 5%
		IPD	110 k Ω , \pm 5%
	Medium acceleration	Double align	22 k Ω , \pm 5%
		IPD	150 k Ω , \pm 5%
	High acceleration	Double align	30 k Ω , \pm 5%
		IPD	200 k Ω , \pm 5%
	Very high acceleration	Double align	39 k Ω , \pm 5%
		IPD	240 k Ω , \pm 5%
	Ultra-high acceleration	Double align	51 k Ω , \pm 5%
		IPD	300 k Ω , \pm 5%

Table 3-12. RMP_2 Pin Resistor Values

Pin	Motor Startup Profile	Startup Method	Resistor Value
RMP_2	All profiles	IPD and Double align	4.7 k Ω , \pm 5%

3.3 Abnormal Speed Threshold

MCT8316AT monitors the speed continuously by calculating difference in time between subsequent back EMF zero crossings. Abnormal speed lock gets triggered when motor speed exceeds abnormal speed threshold. When the motor gets stuck in the first electrical cycle, device continues to commutate at frequencies above the configured abnormal speed threshold.

It is recommended to configure the abnormal speed threshold to 150% of maximum electrical speed of the motor in Hz.

3.3.1 Selecting CONFIG_3 Pin Resistor

Refer to [Table 3-13](#) to select the appropriate CONFIG_3 resistor value based on the Abnormal speed threshold. If the calculated abnormal speed threshold does not match the values listed in [Table 3-13](#), pick a value that is greater than the calculated value.

Table 3-13. CONFIG_3 Pin Resistor Values

Abnormal Speed Threshold (Hz)	CONFIG_3 Pin Resistor Value
1000	Tie to GND
2000	30 k Ω , \pm 5%
3000	91 k Ω , \pm 5%
4000	300 k Ω , \pm 5%

3.4 PWM Switching Frequency

It is recommended to choose PWM switching frequency as 75 kHz or 100 kHz for very low inductance and very high-speed motors to avoid discontinuous phase currents.

It is recommended to choose PWM switching frequency below 50 kHz for very high inductance motors and also to minimize PWM switching losses. Please note that selecting PWM switching frequency below 20 kHz will result in audible switching noise.

3.4.1 Selecting CONFIG_1 Pin Resistor

Select appropriate CONFIG_1 pin resistor from [Table 3-14](#) based on the recommendations provided to select PWM switching frequency.

Table 3-14. CONFIG_1 pin resistor values

Pin	PWM switching frequency (kHz)	CONFIG_1 pin resistor value
CONFIG_1	10	Tie to GND
	20	10 kΩ, ±5%
	25	22 kΩ, ±5%
	40	39 kΩ, ±5%
	50	62 kΩ, ±5%
	60	91 kΩ, ±5%
	75	150 kΩ, ±5%
	100	240 kΩ, ±5%

3.5 Lead Angle

To achieve the best efficiency, it is often desirable to control the drive state of the motor so that the motor phase current is aligned with the motor BEMF voltage. MCT8316AT provides the option to advance or delay the phase voltage from the commutation point by adjusting lead angle. In BLDC applications, the lead angle should be adjusted to obtain optimal efficiency. This can be accomplished by operating the system at constant speed and load conditions and adjusting lead angle until the minimum current is achieved.

3.5.1 Steps to Tune Lead Angle

To tune the lead angle, start with the default lead angle of 0 degrees by connecting LDANGLE pin to GND, then:

1. Successfully run the motor at 100% speed
2. Record the motor phase current (I_{ph}).
3. Record the frequency on the FG pin (f_{FG}) which corresponds to the motor speed.
4. Next, calculate the ratio of phase current over motor speed (I_{ph} / f_{FG})

Repeat steps 1 to 4 with lead angle of 10 degrees (populate 30 kΩ, ±5%) and 20 degrees (populate 91 kΩ, ±5%) in LDANGLE pin.

The lowest ratio of phase current over motor speed (I_{ph} / f_{FG}) with the highest speed is the most efficient lead angle.

3.5.2 Selecting LDANGLE pin resistor

Refer to [Table 3-15](#) to select the appropriate LDANGLE resistor value based on the lead angle selected in [Section 3.5](#).

Table 3-15. LDANGLE pin resistor values

Lead angle (degrees)	LDANGLE pin resistor value
0	Tie to GND

Table 3-15. LDANGLE pin resistor values (continued)

Lead angle (degrees)	LDANGLE pin resistor value
10	30 kΩ, ±5%
20	91 kΩ, ±5%

3.6 Slew Rate and Buck Voltage

It is recommended to increase the Slew rate to reduce switching losses and maximize thermal efficiency. However, increasing the slew rate will increase the EMI noise. In applications where EMI noise is a concern, it is recommended to decrease the slew rate. Slew rate in MCT8316AT can be configured to 25 V/μs, 50 V/μs, 125 V/μs and 200 V/μs.

Buck regulator output in MCT8316AT can be configured to 3.3 V or 5 V.

3.6.1 Selecting SLEW_RATE Pin Resistor

Refer to [Table 3-16](#) to select the appropriate SLEW_RATE resistor value based on the selected slew rate and buck voltage.

Table 3-16. SLEW_RATE pin resistor values

Slew rate (V/μs)	Buck voltage (V)	SLEW_RATE pin resistor value
25	3.3	Tie to GND
	5	62 kΩ, ±5%
50	3.3	10 kΩ, ±5%
	5	91 kΩ, ±5%
125	3.3	22 kΩ, ±5%
	5	150 kΩ, ±5%
200	3.3	39 kΩ, ±5%
	5	240 kΩ, ±5%

4 Revision History

NOTE: Page numbers for previous revisions may differ from page numbers in the current version.

DATE	REVISION	NOTES
October 2021	*	Initial Release

IMPORTANT NOTICE AND DISCLAIMER

TI PROVIDES TECHNICAL AND RELIABILITY DATA (INCLUDING DATA SHEETS), DESIGN RESOURCES (INCLUDING REFERENCE DESIGNS), APPLICATION OR OTHER DESIGN ADVICE, WEB TOOLS, SAFETY INFORMATION, AND OTHER RESOURCES "AS IS" AND WITH ALL FAULTS, AND DISCLAIMS ALL WARRANTIES, EXPRESS AND IMPLIED, INCLUDING WITHOUT LIMITATION ANY IMPLIED WARRANTIES OF MERCHANTABILITY, FITNESS FOR A PARTICULAR PURPOSE OR NON-INFRINGEMENT OF THIRD PARTY INTELLECTUAL PROPERTY RIGHTS.

These resources are intended for skilled developers designing with TI products. You are solely responsible for (1) selecting the appropriate TI products for your application, (2) designing, validating and testing your application, and (3) ensuring your application meets applicable standards, and any other safety, security, regulatory or other requirements.

These resources are subject to change without notice. TI grants you permission to use these resources only for development of an application that uses the TI products described in the resource. Other reproduction and display of these resources is prohibited. No license is granted to any other TI intellectual property right or to any third party intellectual property right. TI disclaims responsibility for, and you will fully indemnify TI and its representatives against, any claims, damages, costs, losses, and liabilities arising out of your use of these resources.

TI's products are provided subject to [TI's Terms of Sale](#) or other applicable terms available either on ti.com or provided in conjunction with such TI products. TI's provision of these resources does not expand or otherwise alter TI's applicable warranties or warranty disclaimers for TI products.

TI objects to and rejects any additional or different terms you may have proposed.

Mailing Address: Texas Instruments, Post Office Box 655303, Dallas, Texas 75265
Copyright © 2022, Texas Instruments Incorporated