

Power Through the Isolation Barrier: The Landscape of Isolated DC/DC Bias Power Supplies



Ryan Manack
Business Lead
Texas Instruments



As power levels in high-voltage systems continue to increase, designers need to transfer signals and power across the isolation barrier safely.

At a glance

This paper examines various isolated DC/DC bias power supplies to move signals and power across the isolation barrier.

1 Isolated DC/DC supply requirements

With many options available for bias power solutions, it is important to understand the requirements needed for each.

2 Types of isolated bias supply topologies

Several topologies can be used for isolated bias supplies, including flyback, Fly-Buck™, push-pull, LLC and power modules.

3 A next-generation bias solution

Designers can now integrate a transformer and silicon into one IC for a smaller, lightweight solution.

Moving signals and power across an isolation barrier is a common challenge for designers. Isolation might be required for safety, noise immunity or large potential differences between system domains. For example, a cellphone charger is internally isolated to prevent humans from becoming electrically tied to the mains if the connector short-circuits. In other applications like factory robots, sensitive control circuitry sits on a separate ground and is isolated from the motors that draw large DC currents and create noise and ground bounces.

Communication and sensing are commonly implemented across an isolation barrier. Automotive applications with Controller Area Network (CAN) or CAN Flexible Data Rate (FD) protocol communications can isolate these signals from the high-voltage side of the automobile using an isolated CAN transceiver that integrates isolation and transceiver components. Industrial applications may also utilize the CAN protocol, but can also use the RS-485 protocol for long-distance serial communications. Similar to isolating CAN and CAN FD signals, designers can leverage isolated transceivers designed for the RS-485 protocol. Protection relays use isolated current and voltage sensors to sense power moving through the grid. Traction inverters and motor drives take a pulse-width modulated (PWM) signal from the motor controller and pass it through an isolator to tell the gate driver to turn an insulated gate bipolar transistor on or off.

Isolated bias converters enable isolated communication and sensing by providing bias power from one side of the isolation barrier to the other. Current and voltage sensors, digital isolators and gate drivers typically require less than 15 W and as little as tens of milliwatts of power.

Figure 1 shows an example of each of these applications.

Isolated DC/DC bias supply requirements

Many solutions can provide isolated bias power, from controllers, which have external power switches; to converters, which integrate a controller

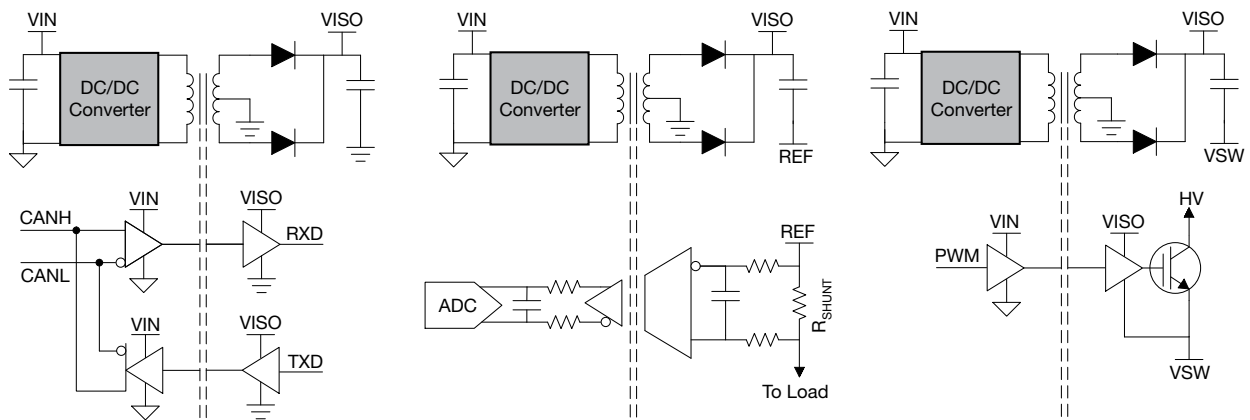

Figure 1. Isolated bias applications.

with power switches; to finally power modules, which integrate controllers, power switches and transformers in one package. Because of this wide variety of bias power solutions and the diverse applications that they go into, it is important to fully understand the application requirements in order to meet the specifications at the lowest cost.

At minimum, designers should understand the bias supply input voltage range, the output voltage and the output power requirements. Some applications will require more than one bias voltage so it is important to define the acceptable regulation for each output. System requirements such as the insulation rating, ambient operating temperature range, EMI and electromagnetic compatibility (EMC) will further drive design decisions. **Table 1** shows

just four examples of an extremely broad landscape of isolated bias converter specifications. Let's review some example isolated bias supply topologies.

Flyback

The flyback converter is a well-known topology that has been widely used for decades. This power converter can support a wide variety of applications due to its flexibility and low cost. Advancements such as field-effect transistor (FET) integration and primary-side control make this topology even more attractive.

Compared to buck-derived topologies like forward, push-pull and half-bridge, the flyback topology requires only one primary switch, one rectifier and

	Traction inverter SiC gate driver bias	Isolated current or voltage sensing	Isolated CAN communication	Industrial motor IGBT gate driver bias
Input voltage	12V ± 10%	5V	5V	24V ± 10%
Output voltages	+20V / -5V	5V	5V	+15V / -5V
Output power	1.5W	100mW	350mW	1W
Regulation	± 5 %	± 10%	± 5%	± 10%
Insulation rating	Basic	Reinforced	Reinforced	Reinforced
Ambient temperature	Up to 105°C	-55°C to 125°C	-40°C to 125°C	-40°C to 85°C
Electromagnetic interference (EMI) needs	Comité International Spécial des Perturbations Radioélectriques (CISPR) 25 Class 5	CISPR 32 Class B	CISPR 25 Class 5	CISPR 32 Class B

Table 1. Example isolated bias converter specifications.

one transformer-like coupled inductor. **Figure 2** shows a simplified schematic of the converter. When the primary switch is on, the input voltage is applied across the primary winding, storing energy in the transformer's air gap. The output load is supported only by the output capacitor in this state. When the primary switch turns off, the energy stored in the transformer is delivered to the secondary through the rectifier to supply the load and recharge the output capacitors.

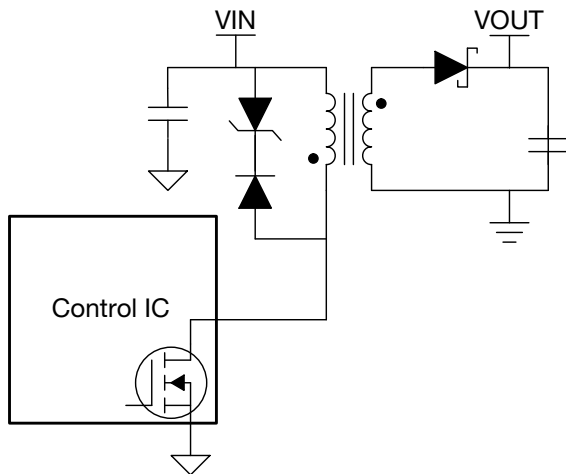

Figure 2. A flyback converter.

A flyback converter performs well as a bias converter for a number of reasons. It provides regulation and isolation in one conversion stage. Its flexibility is also useful for multiple outputs. You can choose the number of output windings and wind the transformer to support your chosen configuration. The corresponding voltage on the output windings is a function of the duty cycle and the primary-to-secondary windings' turns ratio. It is also possible to reference each output to a different ground in order to meet system isolation requirements. Other flyback benefits include its relatively low cost and wide input-to-output operating range.

It is important to properly design a flyback transformer for best performance. The transformer should be very well-coupled, with low leakage inductance for the highest efficiency and best regulation, especially in multiple outputs. However,

it is also necessary to limit the parasitic capacitance from the primary to secondary in order to prevent excessive EMI.

Fly-Buck converter

A Fly-Buck converter is a Texas Instruments-specific topology used to create an isolated bias supply. It is capable of operating from input voltages as high as 100 V. Like a flyback converter, metal-oxide semiconductor field-effect transistors (MOSFETs) are typically integrated inside the integrated circuit (IC), and it is very simple to realize primary-side control. **Figure 3** shows a Fly-Buck converter.

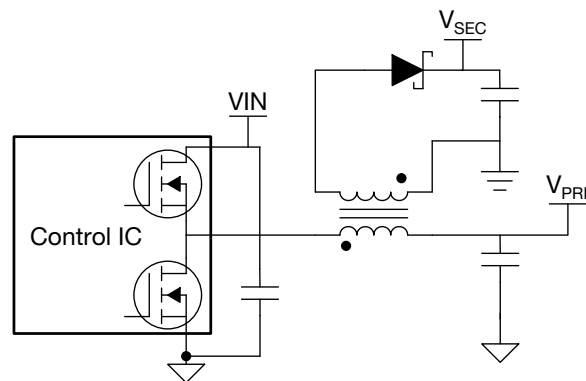

Figure 3. A Fly-Buck™ converter.

The topology uses a synchronous buck converter with a coupled inductor to create one or multiple isolated outputs. When the high-side switch is on, the primary side works like a buck converter and the secondary winding current is zero. In the off-state when the low-side switch is on the secondary side is driven from energy stored in the primary.

Synchronous buck converters are widely available, making the Fly-Buck converter an attractive topology. The converter does not require an additional auxiliary winding or optocoupler for control, as the feedback loop can be closed on the primary output voltage. The coupled-inductor construction is flexible. The turns ratio, insulation rating, number of secondary windings and PWM duty cycle are controllable for use in a wide variety of applications.

Like the flyback converter, the coupled inductor

must be properly designed. It is important to manage the leakage inductance while limiting the parasitic capacitance from primary to secondary. For applications requiring greater than 100-V inputs, you can use a Fly-Buck converter with an external MOSFET.

Push-pull transformer driver

A push-pull transformer driver is a common solution for low-noise, small-form-factor isolated power supplies. It is supplied from a tightly regulated input rail and operates in an open loop at a fixed 50% duty cycle. MOSFETs are integrated into the IC, enabling a compact solution.

Figure 4 shows the push-pull topology. The push-pull topology is a double-ended variant of the forward topology with both MOSFETs ground-referenced, eliminating the need for external bootstrap circuitry. Similar to the single-ended forward converter, the voltage stress at the FETs is two times the input voltage. The MOSFETs switch at a 50% duty cycle during alternate half cycles, driving the center-tapped winding of the transformer.

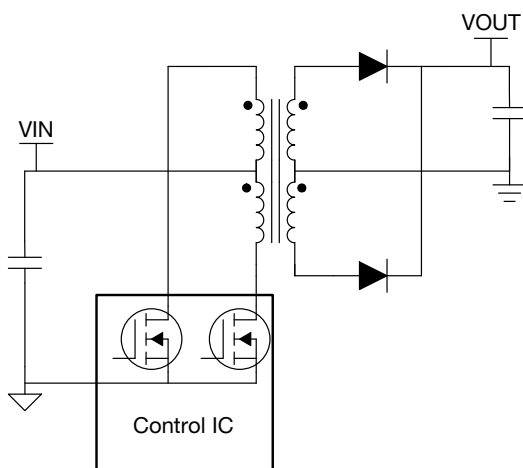

Figure 4. A push-pull transformer driver.

The push-pull transformer driver is a prevalent isolated bias power-supply solution for many reasons. It offers flexibility and the ability to support multiple outputs. The open-loop configuration provides design simplicity by eliminating the

feedback loop. The push-pull transformer offers lower primary-secondary capacitance, which enables a reduction in common-mode noise compared to flyback and Fly-Buck converters.

Additionally, the push-pull topology more efficiently uses the transformer core magnetizing current, resulting in a smaller magnetic solution compared to flyback and Fly-Buck converters.

Although the transformer driver carries a number of advantages, it is also important to take into account the trade-offs. Unlike the flyback and Fly-Buck converters, the transformer driver cannot support a wide input voltage range, and instead requires a tightly regulated input voltage. Meeting the output-voltage regulation requirements for feedback can be challenging due to the absence of a closed loop and may require a low-dropout post-regulator (LDO).

LLC converters

Most transformer drivers have evolved from their push-pull predecessors to resonant converters such as the inductor-inductor-capacitor (LLC) topology in a half-bridge configuration. Although the MOSFET switching control is the same – each MOSFET turning on alternatively with a 50% duty cycle and the converter in open-loop operation – the LLC topology brings additional benefits to the system.

Figure 5 shows the LLC half-bridge topology. Like the push-pull, the LLC topology is double-ended. The transformer is driven by MOSFETs configured in a half-bridge with external series resonant capacitance. The capacitance and leakage inductance in the transformer provide a series resonant circuit. Energy is through the current in the resonant circuit transferred from the primary to the secondary load. In this topology the primary and secondary currents are sinusoidal because of the operation from the series resonant circuit.

Major benefits of the LLC topology include higher efficiency, lower EMI and lower capacitance across the isolation barrier (which helps increase common-mode transient immunity [CMTI] reliability).

Transformer leakage inductance is not a concern anymore for noise or energy loss; actually, it becomes part of the series resonant circuit.

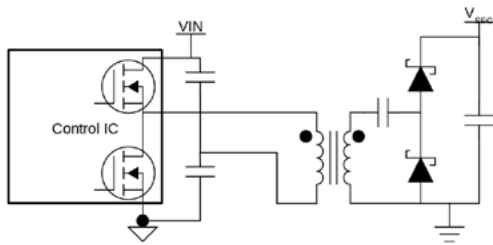

Figure 5. An LLC converter.

Push-pull transformers require four windings that must be tightly coupled to reduce leakage inductance. Only two windings are needed in an LLC converter, which reduces cost. The two windings are intentionally separated in a split-chamber bobbin that eliminates the need for thick wire insulation or insulating tape, further reducing cost. The leakage inductance is higher by design, and the primary-to-secondary capacitance of the transformer can be as much as an order of magnitude below flyback and push-pull transformers – a major benefit for EMI and CMTI.

In the past, the LLC topology was predominant in higher-voltage, higher-power systems in order to increase switching frequencies, reduce switching losses, achieve higher efficiency, reduce the size of magnetics and simplify the transformer structure. The same benefits are now possible in sub-15-W bias supplies; the switching frequency can increase beyond 1 MHz to further reduce converter size and cost while improving converter performance simultaneously. More and more designers are moving to the LLC topology to further achieve higher performance and higher reliability at a lower system cost.

Power modules

Power modules have existed for decades. These solutions are widely available and offer significant integration compared to discrete implementations. Power modules exist in many varieties, with input

voltage, output voltage, output power, number of outputs, isolation rating and regulation options.

Figure 6 shows the block diagram of the inner workings of one power module. The topology includes a transformer driver similar to the discrete version. Some devices may integrate an output LDO for regulation.

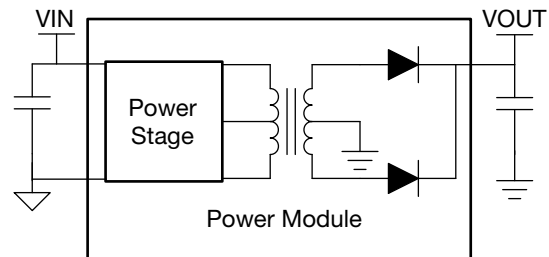

Figure 6. A power module.

With many options available, you can use a power module in most isolated bias converter applications. They greatly simplify the design process because you do not need to specify, design or choose a transformer; you only need to include an input and output decoupling capacitor to start the design. Other options like synchronization, output voltage selection, enable and error signaling are available as well.

You will lose some flexibility with modules, specifically to configure the number of outputs and transformer turns ratios. The selection of modules rated for a 125°C ambient temperature range is less than for the 55°C and 85°C options. Similarly, the number of modules available with fully reinforced insulation ratings is less than those modules available with functional or basic isolation.

A next-generation bias solution

Innovations in transformer design and higher frequency topologies have enabled IC designers to integrate a transformer and silicon into one IC. The end user gets a small, lightweight isolated DC/DC bias power supply without having to design a transformer or compromise on system performance.

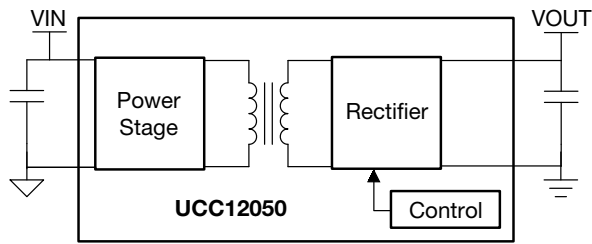

Figure 7. The UCC12050 isolated DC/DC bias power supply.

Figure 7 shows the block diagram of the Texas Instruments [UCC12050](#). Although it looks similar to a power module with an integrated power stage and rectifier, a closer look at the UCC12050 operation shows that the switching frequency is much higher compared to power modules. This enables significant height and weight reduction versus lower switching frequency alternatives. The internal topology control scheme runs closed-loop without an LDO or external feedback components.

The UCC12050 brings many benefits to the wide variety of isolated DC/DC bias supply applications. It is designed with an EMI-optimized transformer with only 3.5 pF of primary-to-secondary capacitance and a quiet control scheme. On its own the solution can pass CISPR32 Class B on a two-layer printed

circuit board without ferrite beads or LDOs. The device is robust, rated for reinforced isolation of 5 kVrms and a 1.2-kVrms working voltage, and will operate at a 125°C ambient temperature. The family of devices also includes the [UCC12040](#), which is rated for basic isolation of 3 kVrms and a 800-Vrms working voltage.

The UCC12050 is targeted for 5-V input, 3.3-V to 5.4-V output applications requiring 500 mW. Applications requiring higher input or output voltages will need to provide pre-or-post conversion. Also, for designs requiring power above the UCC12050’s derating curve, alternative topologies should be explored.

Table 2 compares each of the described topologies. It is clear that topologies with external transformers offer the most flexibility while power modules and the UCC12050 provide the most ease of use.

Conclusion

You have many options to provide power across an isolation boundary. Understanding system-level specifications like the number of outputs, regulation

	No. of outputs	Regulation	Output power	Insulation rating	Operating temperature
Flyback converter	Flexible – XFMR Dependent	PSR or Optocoupler Only One Winding Regulated	Up to 15W	Flexible – XFMR Dependent	Flexible – XFMR Dependent
Fly-buck™ converter	Flexible – XFMR Dependent	PSR or Optocoupler	5 to 10W	Flexible – XFMR Dependent	Flexible – XFMR Dependent
Transformer driver	Flexible – XFMR Dependent	Unregulated	1 to 5W	Flexible – XFMR Dependent	Flexible – XFMR Dependent
LLC converters	Flexible – XFMR Dependent	Regulated or Unregulated	Up to 10W	Flexible – XFMR Dependent	Flexible – XFMR Dependent
Power modules	1 to 2 Outputs	Regulated or Unregulated	1 to 3W	Mostly Basic or Functional	Typically 85°C
UCC12050	1 Output	Regulated	0.5W	Reinforced	125°C

Table 2. Isolated bias power supply topology comparison.

requirements, output power, insulation rating, operating temperature and input voltage range are critical. From there, you can derive the lowest-cost solution that meets all of your system requirements.

Important Notice: The products and services of Texas Instruments Incorporated and its subsidiaries described herein are sold subject to TI's standard terms and conditions of sale. Customers are advised to obtain the most current and complete information about TI products and services before placing orders. TI assumes no liability for applications assistance, customer's applications or product designs, software performance, or infringement of patents. The publication of information regarding any other company's products or services does not constitute TI's approval, warranty or endorsement thereof.

The platform bar and Fly-Buck are trademarks of Texas Instruments. All other trademarks are the property of their respective owners.

IMPORTANT NOTICE AND DISCLAIMER

TI PROVIDES TECHNICAL AND RELIABILITY DATA (INCLUDING DATASHEETS), DESIGN RESOURCES (INCLUDING REFERENCE DESIGNS), APPLICATION OR OTHER DESIGN ADVICE, WEB TOOLS, SAFETY INFORMATION, AND OTHER RESOURCES "AS IS" AND WITH ALL FAULTS, AND DISCLAIMS ALL WARRANTIES, EXPRESS AND IMPLIED, INCLUDING WITHOUT LIMITATION ANY IMPLIED WARRANTIES OF MERCHANTABILITY, FITNESS FOR A PARTICULAR PURPOSE OR NON-INFRINGEMENT OF THIRD PARTY INTELLECTUAL PROPERTY RIGHTS.

These resources are intended for skilled developers designing with TI products. You are solely responsible for (1) selecting the appropriate TI products for your application, (2) designing, validating and testing your application, and (3) ensuring your application meets applicable standards, and any other safety, security, or other requirements. These resources are subject to change without notice. TI grants you permission to use these resources only for development of an application that uses the TI products described in the resource. Other reproduction and display of these resources is prohibited. No license is granted to any other TI intellectual property right or to any third party intellectual property right. TI disclaims responsibility for, and you will fully indemnify TI and its representatives against, any claims, damages, costs, losses, and liabilities arising out of your use of these resources.

TI's products are provided subject to TI's Terms of Sale (<https://www.ti.com/legal/termsofsale.html>) or other applicable terms available either on [ti.com](https://www.ti.com) or provided in conjunction with such TI products. TI's provision of these resources does not expand or otherwise alter TI's applicable warranties or warranty disclaimers for TI products.

Mailing Address: Texas Instruments, Post Office Box 655303, Dallas, Texas 75265
Copyright © 2021, Texas Instruments Incorporated