

User's Guide

AM572x Industrial Development Kit (IDK) Evaluation Module (EVM) Hardware



1 Read This First

1.1 About This Manual

This document describes the hardware architecture of the AM572x Industrial Development Kit (IDK) Evaluation Module (EVM) (Part# TMDXIDK572x) that supports the Texas Instruments Sitara™ ARM® Cortex®-A15 AM572x processor family.

1.2 Related Documentation From Texas Instruments

For product information, visit the Texas Instruments website at <http://www.ti.com>.

[SPRABY8 AM572x GP EVM Power Simulations Application Report](#)

[SPRS953 AM572x Sitara Processors Silicon Revision 2.0 Data Manual](#)

[SPRZ429 AM572x Sitara Processors Silicon Errata](#). Describes the known exceptions to the functional specifications for the device.

[SPRUHZ6 AM572x Sitara Processors Technical Reference Manual](#). Details the integration, the environment, the functional description, and the programming models for each peripheral and subsystem in the device.



This design incorporates HDMI® technology.

Table of Contents

1 Read This First	2
1.1 About This Manual.....	2
1.2 Related Documentation From Texas Instruments.....	2
2 AM5724x Industrial Development Kit (IDK) Evaluation Module (EVM) Hardware	5
2.1 Introduction.....	5
2.2 Functional Description.....	10
2.3 Power Supplies.....	12
2.4 Configuration/Setup.....	14
2.5 Memories Supported.....	16
2.6 Ethernet Ports.....	17
2.7 USB Ports.....	18
2.8 PCIe.....	18
2.9 Video Input and Output.....	19
2.10 Industrial Interfaces.....	19
2.11 User Interfaces.....	20
2.12 Pin Use Description.....	20
2.13 Board Connectors.....	22
2.14 EVM Important Notice.....	34
3 Known Deficiencies in AM5724x IDK EVM	35
3.1 Power solution not sufficient for full PCIe plug-in card compliance.....	35
3.2 Early versions of the AM572x IDK EVM not installed with SOC devices rated for the full industrial temperature range.....	35
3.3 AM572x IDK EVM does not support eMMC HS200 mode.....	35
3.4 PCIe PERSTn line not in proper state at start-up.....	35
3.5 EDIO connectors J4 and J7 should support real-time debugging for both PRU1 and PRU2.....	35
3.6 HDQ implementation not correct.....	35
3.7 Removing the power plug and inserting it again while the power supply is energized may cause damage.....	35
3.8 Software shutdown of PMIC not operational.....	35
3.9 PMIC implementation does not support required SOC shut-down sequence.....	35
3.10 USB port providing UART console and XDS100 emulation not isolated from EVM board supplies.....	36
3.11 Need 47-µf capacitor at camera header.....	36
3.12 Decoupling capacitors do not reflect AM572x PDN recommendations.....	36
3.13 CCS System Reset fails.....	36
3.14 AM572x IDK EVM design contains 2 clamp circuits that may not be necessary.....	37
3.15 Crystal connected to osc0 needs to have 50 ppm or better long term accuracy.....	37
3.16 Software must program the CDCE913 for 0-pf load capacitance.....	37
3.17 Protection diode D2 should be rated for 5 V.....	37
3.18 PHY address LSB for U9 and U15 can be latched incorrectly.....	37
3.19 3.3-V clamp circuit needs more margin.....	37
3.20 Current PMIC does not provide the mandated power down sequence.....	37
3.21 PMIC OSC16MCAP pin mistakenly grounded.....	38
4 Revision History	39

List of Figures

Figure 2-1. AM572x IDK EVM - Top View.....	6
Figure 2-2. AM572x IDK EVM - Bottom View.....	7
Figure 2-3. AM572x IDK EVM with LCD Display Assembly Attached - Top View.....	8
Figure 2-4. AM572x IDK EVM with LCD Display Assembly Attached - Bottom View.....	9
Figure 2-5. AM572x IDK EVM Block Diagram.....	10
Figure 2-6. Connections from the TPS6590377 PMIC to the AM572x Processor.....	13

List of Tables

Table 2-1. I2C1/IND_I2C.....	14
Table 2-2. I2C2/AM572X_HDMI_DDC.....	14
Table 2-3. SEEPROM Header.....	15
Table 2-4. PRU-ICSS Ethernet Ports.....	17
Table 2-5. GPIO Pin Mapping.....	21
Table 2-6. Expansion Connector - J21.....	22
Table 2-7. I/O Expansion Header Connector - J37.....	23
Table 2-8. MicroSD Connector - J15.....	24

Table 2-9. Power Jack Connector - J1.....	24
Table 2-10. Power Terminal Block Connector - J2.....	24
Table 2-11. PRU1ETH0 RJ45 Connector - J3.....	24
Table 2-12. PRU1ETH1 RJ45 Connector - J5.....	25
Table 2-13. PRU2ETH0 RJ45 Connector - J6.....	25
Table 2-14. PRU2ETH1 RJ45 Connector - J8.....	26
Table 2-15. PRU2ETH0 Test Header Connector - J7.....	26
Table 2-16. PRU2ETH1 Test Header Connector - J4.....	26
Table 2-17. Camera Connector - J9.....	26
Table 2-18. GigE RJ45 Connector - J10.....	27
Table 2-19. GigE RJ45 Connector - J12.....	27
Table 2-20. LCD Module FFC Connector - J16.....	29
Table 2-21. Touchscreen Controller FFC Connector - J17.....	29
Table 2-22. HDMI Standard A-type Connector - J24.....	30
Table 2-23. MIPI-60 JTAG Connector - J18.....	30
Table 2-24. JTAG USB Micro-AB Connector - J19.....	32
Table 2-25. USB Port 1 USB3.0 Standard A-type Connector - J23.....	32
Table 2-26. USB Port 2 USB2.1 Micro-AB Connector - J45.....	32
Table 2-27. CAN Header Connector - J38.....	32
Table 2-28. Profibus DB9F Connector - J14.....	33
Table 2-29. RS-485 Header Connector - J39.....	33
Table 2-30. PCIe Connector – J22.....	33

Trademarks

Sitara™, Code Composer Studio™, and SmartReflex™ are trademarks of Texas Instruments.
 is a trademark of TI.

ARM® and Cortex® are registered trademarks of ARM Limited.

Windows® is a registered trademark of Microsoft Corporation.

All trademarks are the property of their respective owners.

The terms HDMI, HDMI High-Definition Multimedia Interface, HDMI trade dress, and the HDMI Logos are trademarks or registered trademarks of HDMI Licensing Administrator Inc.

2 AM5724x Industrial Development Kit (IDK) Evaluation Module (EVM) Hardware

2.1 Introduction

This document describes the hardware architecture of the AM572x Industrial Development Kit (IDK) Evaluation Module (EVM) (Part# TMDXIDK572x) that supports the Texas Instruments Sitara™ ARM® Cortex®-A15 AM572x processor family.

2.1.1 Description

The AM572x IDK is a standalone test, development, and evaluation module that enables developers to write software and develop hardware for industrial control and industrial communications applications. It has been equipped with a TI AM5728 processor and a defined set of features to allow you to experience industrial communication solutions using various serial or Ethernet based interfaces. Using standard interfaces, the AM572x IDK may interface to other processors or systems and act as a communication gateway or controller. In addition, it can directly operate as a standard remote I/O system or a sensor connected to an industrial communication network.

The AM572x IDK contains embedded emulation circuitry to quickly enable developers to begin using this IDK. The embedded emulation logic allows emulation and debug using standard development tools such as the Texas Instruments Code Composer Studio™ integrated development environment (IDE) by simply connecting a USB cable to a Windows®-based computer.

The standard configuration for the AM572x IDK EVM provides the following Ethernet connectivity:

- Two Gigabit (1000Mb) metallic ports connected via PHY/RGMII to the on-chip Ethernet switch
- Two 100Mb metallic ports connected via PHY/MII to the PRU-ICSS subsystems

Reconfiguration through resistor removal and installation can provide an alternate Ethernet connectivity:

- Four 100Mb metallic ports connected via PHY/MII to the PRU-ICSS subsystems

Software support for the AM572x IDK EVM is provided within the Processor Software Development Kit (SDK) package. This includes both Linux and RTOS support.

2.1.2 System View

The system view of the AM572x IDK EVM consists of the main board and the camera board. There is also an optional LCD panel and touch screen assembly that can be attached to the AM572x IDK EVM.

The top and the bottom views of the AM572x IDK EVM are provided in [Figure 2-1](#) and [Figure 2-2](#), respectively.

The top and the bottom views of the AM572x IDK EVM with the optional LCD display assembly attached are provided in [Figure 2-3](#) and [Figure 2-4](#), respectively.

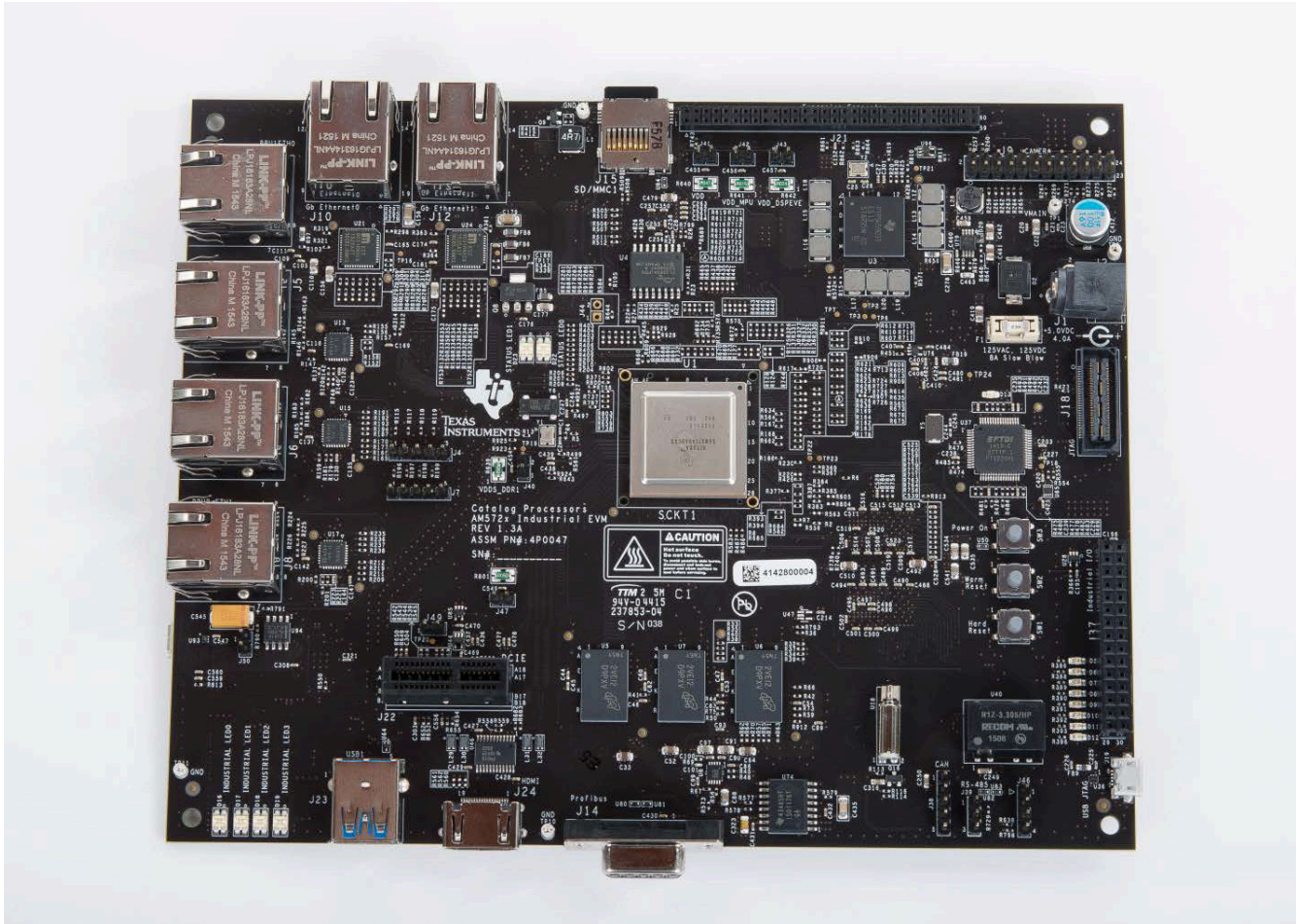

Figure 2-1. AM572x IDK EVM - Top View

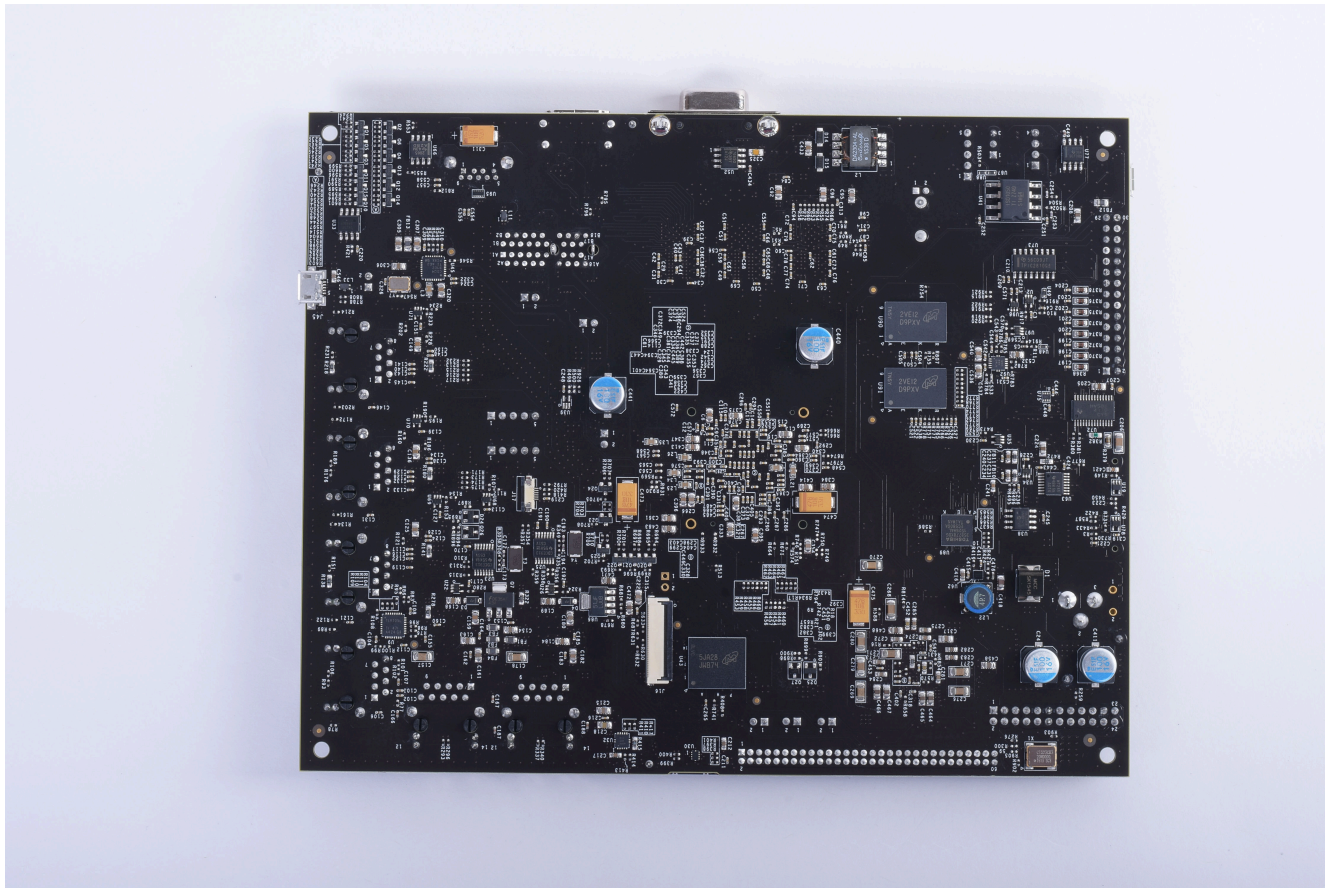

Figure 2-2. AM572x IDK EVM - Bottom View



Figure 2-3. AM572x IDK EVM with LCD Display Assembly Attached - Top View



Figure 2-4. AM572x IDK EVM with LCD Display Assembly Attached - Bottom View

2.2 Functional Description

The AM572x IDK EVM is implemented on a single board with interface circuitry, memory ICs, and connectors around the AM5728 processor. The board also contains power conversion circuitry to efficiently create the needed power supply voltages from a single +5V input. As stated previously, this EVM ships with a separate camera module that plugs in to the main board. An optional LCD panel and touch screen assembly can be purchased separately and mounted on to the main board.

Figure 2-5 shows the functional block diagram of the AM572x IDK EVM.

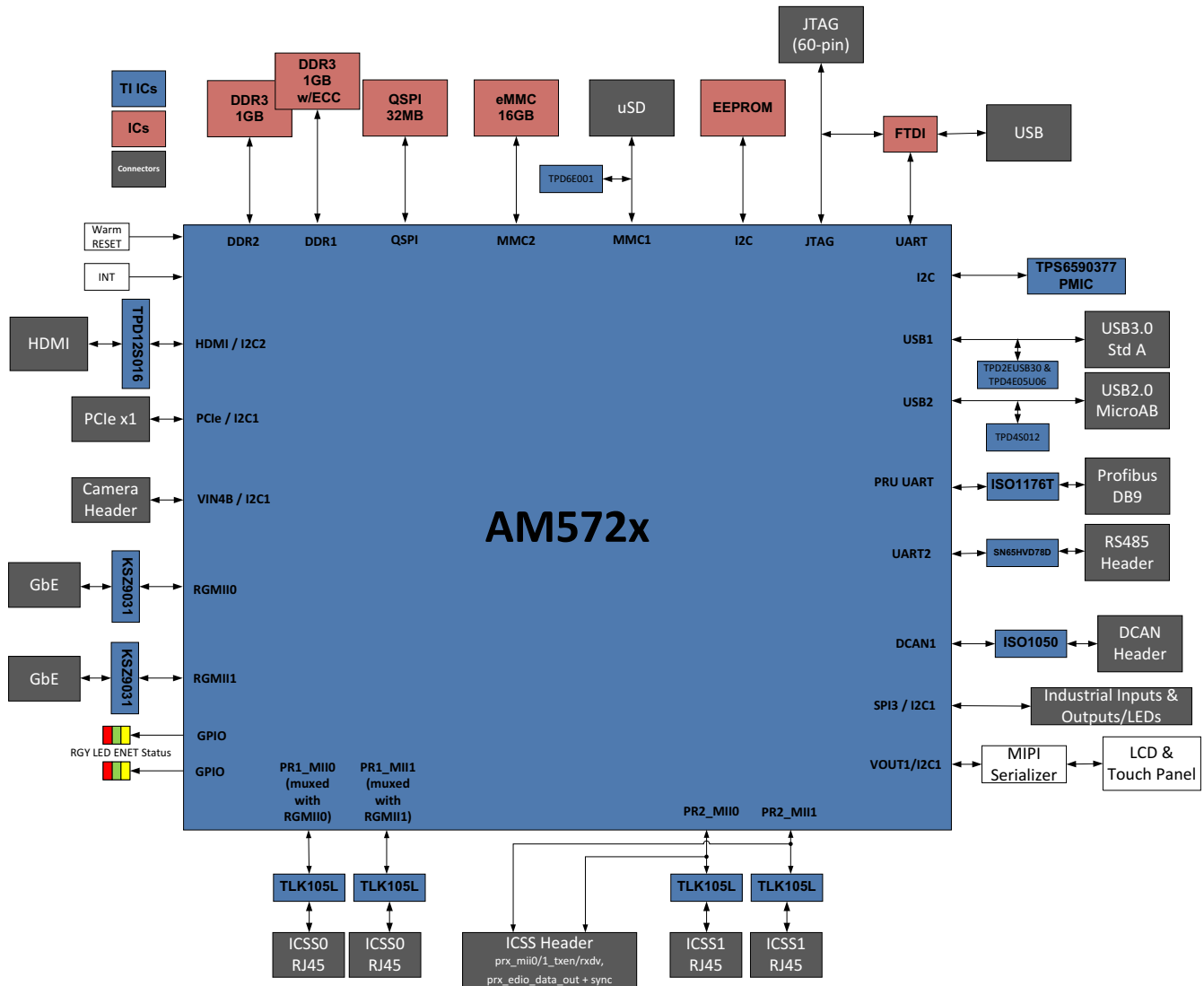

Figure 2-5. AM572x IDK EVM Block Diagram

2.2.1 Processor

The AM5728 processor is the central processing unit for this IDK EVM. The interface circuitry, memory ICs, and connectors implemented on the board around the AM5728 processor provide development support for the many industrial communication interfaces available on this platform. See the [AM572x Sitara Processors Silicon Revision 2.0 Data Manual \(SPRS982\)](#) and the [AM572x Sitara Processors Technical Reference Manual \(SPRUHZ6\)](#) for details about the processor.

The AM572x IDK EVM contains system configuration for the boot mode control inputs SYSBOOT[15..0]. These can be strapped using resistors. The default configuration will meet the needs of most developers. Resistor reconfiguration is supported so that you can explore other boot configurations of the AM572x processor. See [Section 2.4](#) for more details.

2.2.2 Clocks

The main clock for the processor is derived from a 20-MHz crystal. An on-board oscillator in the AM572x processor generates the base clock and the subsequent module clocks as needed within the AM572x processor. The board design supports a crystal attached to the RTC block, but this is not needed since RTC-only mode is not supported in this device.

2.2.3 Reset Signals

The AM572x processor contains 3 reset inputs and an output indicating a reset is in progress. The reset pins are:

- **PORz:** PORz is a hard reset that resets everything including emulation logic. It also tri-states most outputs.
- **RESETn:** RESETn is a device reset commonly driven by control logic or emulation.
- **RTC_PORz:** Separate PORz for the RTC module that must be driven at the same time as PORz. (Note that PORz and RTC_PORz can only be directly connected as long as VDDSHV3 and VDDSHV5 are driven at the same voltage.)
- **RSTOUTn:** Output signal from SOC indicating that the device has entered reset. This is used to reset other circuits that must be reset at the same time as the processor.

More details about the behavior of these reset pins within the AM572x processor can be found in the [AM572x Sitara Processors Silicon Revision 2.0 Data Manual \(SPRS982\)](#). There are push buttons on the IDK that can initiate either a RESETn or PORz input. SW1 can drive PORz active (low) and SW2 can drive RESETn active (low).

There is a device erratum in all of the AM572x devices that prevents use of RESETn independent from PORz. The workaround is to generate PORz whenever a device reset occurs even if it is from an internal initiator. This is accomplished through cooperation with the PMIC paired with the AM572x device on the IDK EVM. The RSTOUTn output from the AM572x device is connected to the NRESWARM input of the PMIC. This initiates a re-start that drives RESET_OUT low and resets all voltages to their initial values. Since RESET_OUT from the PMIC is connected to PORz in the AM572x device, a hard reset is forced on the SOC that meets the needs of the erratum workaround.

The AM572x IDK EVM is started by pressing the start-up push button, SW3. The POWERHOLD input can be connected to VRTC_OUT in customer designs to cause the board to power-on as soon as the main supply is stable.

The configuration of the PMIC to provide RESET_OUT from the NRESWARM input creates an always-on implementation. This always-on mode of operation prevents software shut-down of the IDK. Customer designs should have power-good monitoring circuitry such as a TPS3808 connected to the main supply to the PMIC that is connected to the PMIC RESET_IN. The TPS3808 can detect the main supply voltage dropping and then trigger the PMIC to execute a controlled shut-down that meets the requirements in the [AM572x Sitara Processors Silicon Revision 2.0 Data Manual \(SPRS982\)](#).

2.3 Power Supplies

This section describes how the power supplies required for the design are generated.

2.3.1 Power Source

The AM572x IDK EVM uses an external 5V power supply. The 5V power input is converted into different voltage levels to provide power inputs to the AM572x processor and other circuitry.

Early versions of the AM572x IDK EVM shipped with the GlobTek, Inc. external power supply with the part number TR9CA6500LCP-N, model number GT-43008-3306-1.0-T3. This external power supply is rated for an output voltage of +5VDC with an output current up to 6.5A. This external power supply contains applicable regional product regulatory/safety certification requirements for most worldwide locations. If you cannot use this supply, one with equivalent ratings that is approved for your location must be obtained.

Note that recently sold IDK EVMs do not ship with a power supply in the box due to international concerns. Also note that the power supply listed above is being discontinued. The manufacturer has provided a drop-in replacement. This is the TR9CA8000LCPIM(R6B), which is readily available from distributors such as Digikey.

The AM572x IDK EVM contains a right angle mounted power connector that accepts the +5VDC supply input on the center pin with the outer shell as the common return. The power connector accepts a mating plug with a 2.5mm ID and a 5.5mm OD.

Removing the power plug and inserting it again while the power supply is energized may damage the AM572x IDK EVM and/or other devices attached to the board such as emulators that provide an alternate path to ground. Removal of AC power from the external power supply is a safer method, if required.

It is recommended that the external power supply have the common return bonded to earth ground. If this is not possible, a separate connection from the board ground to earth ground may need to be provided.

2.3.2 TPS6590377 PMIC

The power requirements of the processor are met by the TPS6590377 Power Management IC (PMIC). The power sequencing requirements of the AM572x processor are also handled by the TPS6590377 PMIC. [Figure 2-6](#) shows the supply connections from the TPS6590377 PMIC to the AM572x processor.

Refer to the [AM572x Sitara Processors Silicon Revision 2.0 Data Manual \(SPRS982\)](#) for more information about the required supply voltages and supply sequencing. Also refer to the [TPS659037 Power Management Unit \(PMU\) for Processor Data Manual \(SLIS165\)](#) and the [TPS659037 User's Guide to Power AM572x and AM571x User's Guide \(SLIU011\)](#) for details about its operation.

Note that the production version of the AM572x IDK EVM uses the TPS6590377 PMIC that supplies the voltages needed for the latest silicon version of the AM5728 processor. Beta prototype IDK EVM units used the TPS6590375 PMIC and Alpha prototype IDK EVM units used the TPS6590372 PMIC.

2.3.3 AVS Control

The AM572x processor consumes most of its power in its core logic. Therefore, minimizing the voltage supplied to this core logic can minimize power consumption. SmartReflex™ technology is used to provide this optimized solution.

This core logic is separated into multiple segments that can each be controlled separately. In this way, applications that need more performance in some processing blocks can operate at higher performance levels by increasing the supply voltage, while other processing blocks that do not require the same level of performance can operate at lower voltage thus further optimizing system power consumption.

The TPS6590377 PMIC is connected to the I2C1 on the AM5728 processor. This allows the application software to individually control the AVS supply outputs. It also allows the application to control the voltage generated by LDO1 that is used for the SDIO interface that operates at either 1.8V or 3.3V depending on the operating mode.

2.3.4 Other Power Supplies

The AM572x IDK EVM contains 8 other power conversion devices that support the interface and memory circuitry:

- TPS63010 Buck-Boost Converter: This converter generates 5.0V from the main supply input. It supplies this voltage to the industrial interface circuits, the HDMI interface and to the USB master ports.
- TPS61085 Boost Converter: This converter generates 12.0V from the main supply input. It supplies voltage to the industrial interface circuits and the PCIe card connector.
- TPS51200 DDR Termination Voltage LDO (2 each): This LDO provides the push/pull termination current required for the DDR3 memory interfaces. There is one implemented for each DDR3 EMIF.
- LP38693ADJ Low-Dropout Regulator: This LDO generates the 3.7V LCD bias voltage.
- TPS61081DRC LCD Backlight Generator: This Boost converter generates the LCD backlight supply.
- TPS71712 Low-Dropout Regulator: This LDO generates the 1.2V supply needed for the LCD driver logic.
- TPS76650 Low-Dropout Regulator: This LDO generates the 5.0V supply needed for the Profibus interface.
- R1Z-3.305HP Isolated DC-DC Supply: This converter generates 5.0V isolated from the primary 3.3V DC supply on board for the DCAN interface.

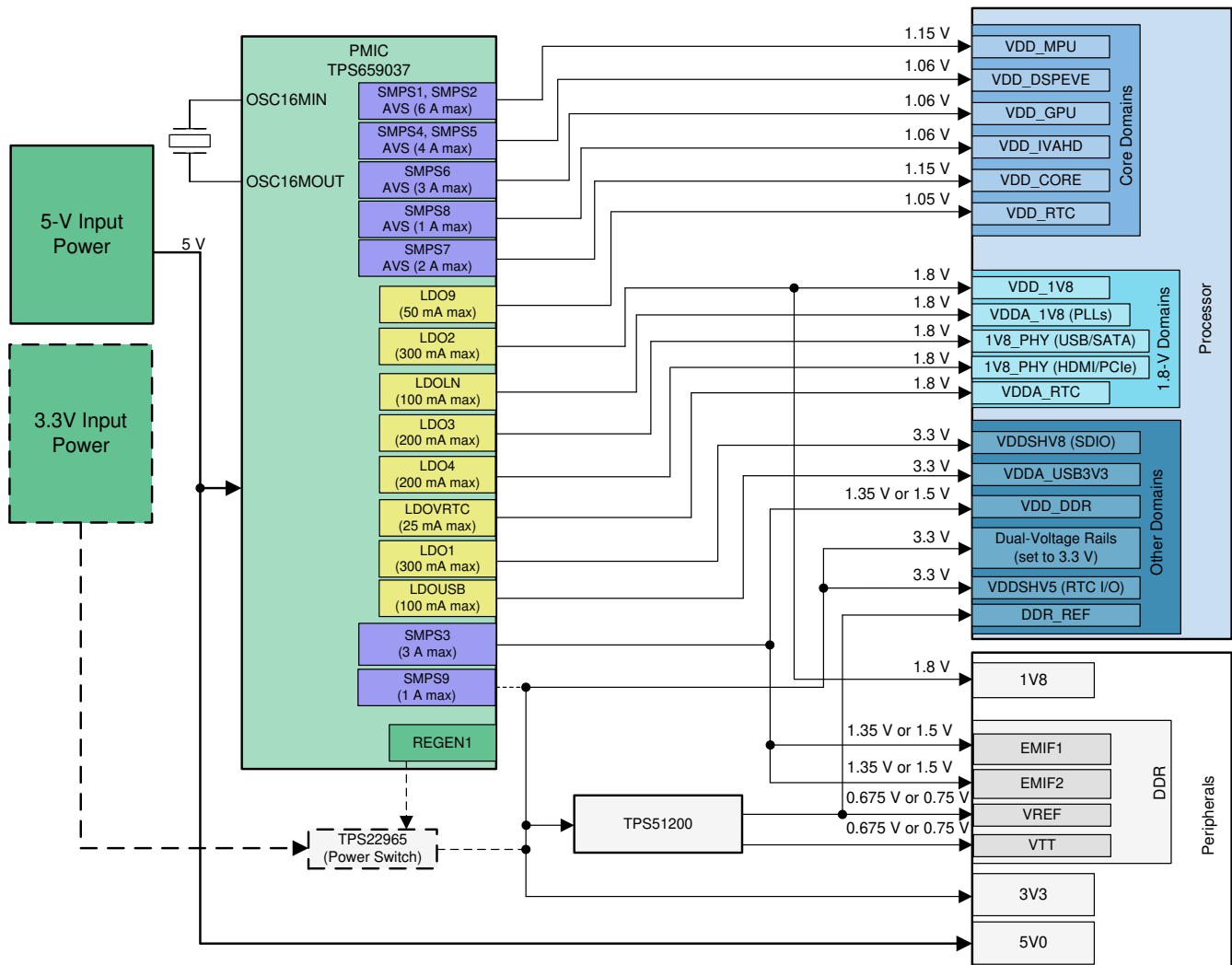

Figure 2-6. Connections from the TPS659037 PMIC to the AM572x Processor

2.4 Configuration/Setup

This section discusses the board configuration.

2.4.1 Boot Configuration

Various boot configurations can be set using the pull-up/pull-down resistor combinations provided on the SYSBOOT[15..0] pins. Boot configuration pins are latched upon de-assertion of the PORz pin. Refer to the [AM572x Sitara Processors Silicon Revision 2.0 Data Manual \(SPRS982\)](#) for more details. The AM572x IDK EVM is configured by default to 0x8106 to enable UBOOT/Linux boot from the SDCARD. The secondary boot device selected by this boot mode is QSPI1.

2.4.2 I2C Address Assignments

The AM572x IDK EVM contains multiple I2C buses connected to a master port on the processor. Each bus contains one or more I2C slave devices that must have unique addresses to prevent contention. [Table 2-1](#) and [Table 2-2](#) list the addresses of the I2C slave devices attached to buses I2C1 and I2C2, respectively.

Table 2-1. I2C1/IND_I2C

I2C Slave Device	Address(es)
TPS590377 PMIC, U3	0x58, 0x59, 0x5A, 0x5B, 0x12
Camera Header, J9	Undefined
CDCE913 Ethernet Clock Generator A, U23	0x65
TPIC2810 Industrial Output Driver, U89	0x60
LCD Panel Driver TC358778, U73	0x0E
Touchscreen FPC Connector, J17	—
ID Memory SEEPROM, U33	0x50
PCIe Card Connector, J22	Undefined
Expansion Connector, J21	Undefined

Table 2-2. I2C2/AM572X_HDMI_DDC

I2C Slave Device	Address(es)
HDMI Bridge, U46	—
CDCE913 Ethernet Clock Generator B, U25	0x65

Note

SCL/SDA names are swapped between the HDMI DDC port and I2C2 port on AM57xx devices – I2C2 schematic connections to U25 must be reversed.

2.4.3 SEEPROM Header

Each of the AM572x IDK EVMs has a unique serial number. This serial number is printed on a sticker attached to the IDK and it is programmed into a SEEPROM memory device connected to the AM5728 processor over the I2C bus. The SEEPROM also contains board details such as board type, version, configuration, and so on. This information is stored in a structure at the beginning of the SEEPROM in a known format that can be read by the application software. These values are all stored with the first character or MSB stored at the lowest addressable location in each field. [Table 2-3](#) lists all of the fields in this header definition.

Table 2-3. SEEPROM Header

Name	Size (bytes)	Contents
Header	4	MSB 0xEE3355AA LSB
Board Name	8	Name for board in ASCII "AM572" = AM572x Industrial Development Kit EVM.
Version	4	Hardware version code for board in ASCII "1.3A" = revision 01.3A
Serial Number	12	Serial number of the board. This is a 12-character string that is: WWYY4P47nnnn, where WW = 2 digit week of the year of production, YY = 2 digit year of production, nnnn = incrementing board number.
Configuration Option	32	Codes to show the configuration setup on this board. Reserved.
Ethernet MAC Address #0	6	Ethernet MAC Address #0 assigned to the AM572x IDK EVM. This is the first of a block of addresses available for the Industrial Interface ports.
Ethernet MAC Address #5	6	Ethernet MAC Address #5 assigned to the AM572x IDK EVM. This is the last of a block of 6 contiguous addresses available for the industrial interface ports.
Available	32696	Available user space for other non-volatile codes/data.

2.4.4 JTAG Emulation

The AM572x IDK EVM supports embedded XDS100V2 USB Emulation through the USB Micro-AB connector, J19, and the FTDI controller. This controller is not powered from the USB, thus the emulation resets whenever the IDK is power cycled.

The AM572x IDK EVM also has a 60-pin MIPI connector to support high-performance external emulators and, optionally, emulation trace. This emulation trace capability is not enabled by default.

2.5 Memories Supported

The AM572x IDK EVM supports on-board memories including DDR3L SDRAM, SPI NOR Flash, eMMC NAND Flash, and I2C EEPROM. It also supports a MicroSD card socket that can add memory storage.

2.5.1 DDR3L SDRAM

The AM572x IDK EVM design supports two banks of DDR3L SDRAM where each is attached to a separate EMIF on the AM5728 processor. Each EMIF can support up to 2GB at speeds up to 1066MT/s. Each EMIF on the IDK EVM contains two 4Gbit (256M × 16) SDRAMs for a total of 1GB of DDR3L SDRAM memory on each EMIF. The part number for the DDR3L SDRAM memory used is MT41K256M16HA-125 that contains timing for 1600MT/s operation. The package used is the 96-ball TFBGA package. See the [AM572x Sitara Processors Technical Reference Manual \(SPRUHZ6\)](#) for memory locations for this memory.

The first EMIF also contains an SDRAM attached to the ECC byte lane. Use of ECC on the DDR3L interface is currently highly constrained by limitations in the AM572x devices. Refer to the [AM574x Sitara Processors Silicon Errata \(SPRZ447\)](#) for more details.

2.5.2 SPI NOR Flash

The AM572x IDK EVM supports a 256Mbit (32MB) SPI Flash Memory from Spansion (S25FL256S) in a 16-pin SOIC package. It is connected to the QSPI port of the AM5728 device.

2.5.3 Board Identity Memory

Each of the AM572x IDK EVM boards contains a 256Kb (32KB) Serial EEPROM that contains board-specific data. This data allows the application software to automatically detect the type of board that it is running on and also to determine its version and, potentially, optional features. Other hardware specific data can be stored on this memory device as well. The part number of the memory device is CAT24C256WI-G in a SOIC-8 package. Refer to [Section 2.4](#) for details on the data stored in this memory.

2.5.4 SD/MMC

The SD/MMC connector on the AM572x IDK EVM is a MicroSD connector (part number SCHA5B0200). This is a standard SD/MMC card type of connector. It is connected to the MMC1 port of the AM572x processor that is optimized for this use. Refer to the [AM572x Sitara Processors Silicon Revision 2.0 Data Manual \(SPRS982\)](#) and the [AM572x Sitara Processors Technical Reference Manual \(SPRUHZ6\)](#) for supported card types and densities.

The SDWP input pin to the MMC1 port is connected to a 2-pin header, J44. The default state has the pin pulled high. Shorting the header pulls the pin low. The polarity of this input is programmable; thus, the hardware does not define whether a high or low level indicates Write Protect is active or not.

The transient protection implemented at the SDCARD connector is the TPD6E001.

2.5.5 eMMC NAND Flash

The MMC2 port on the AM572x processor supports eMMC memory devices, since it has 8 data lines. The eMMC footprint is compliant with the JEDEC/MMC standard. Boards have been assembled and successfully tested with the Kingston EMMC16G-S100 and the Micron MTFC16GAKAECN-2M WT. These are 16GB eMMC NAND Flash memories that are standard version 5.0 compliant.

2.6 Ethernet Ports

The AM572x IDK EVM supports up to four 100Mb Industrial Ethernet ports attached to the PRU-ICSS subsystems and up to two Gigabit (1000Mb) Ethernet ports connected to the integrated Ethernet switch. The final number of available ports depends on the configuration options. The default configuration provides two 100Mb Industrial Ethernet ports and two Gigabit (1000Mb) Ethernet ports.

2.6.1 100Mb Ethernet Ports on PRU-ICSS

The AM572x IDK EVM contains four 100Mb Ethernet ports that each connect to an industrial PHY/Transceiver (TLK105L), which then connect to RJ45 metallic connectors, with integrated magnetics, J3, J5, J6, and J8. These Ethernet transceivers are connected to the PRU1 and PRU2 subsystems within the AM5728 processor. [Table 2-4](#) shows the mapping from the PRU-ICSS ports to the RJ45 connectors.

The COL functionality on the MII interface is not used. The TLK105L contains a feature that must be enabled via software that provides rapid link status on the COL pin. Therefore, this pin is connected to the RXLINK input to the PRU-ICSS ports for this purpose.

Test headers J4 and J7 are available to support real-time code development. The signals contained are available for simplified probing.

The reset for the transceivers is driven low coincident with the PORz reset to the AM5728 processor. The reset for each transceiver can also be driven low individually by separate GPIO signals from the processor. A 25-MHz clock is provided into each of the TLK105L industrial transceivers.

Table 2-4. PRU-ICSS Ethernet Ports

Connector	PRU-ICSS Port	MDIO Address	Notes
J3	PRU1ETH0	0x0 on PRU1	Not available in default configuration. MII pins multiplexed with RGMII0.
J5	PRU1ETH1	0x1 on PRU1	Not available in default configuration. MII pins multiplexed with RGMII1.
J6	PRU2ETH0	0x0 on PRU2	
J8	PRU2ETH1	0x1 on PRU2	

2.6.2 Gigabit (1000Mb) Ethernet Ports

The AM572x IDK EVM contains two Gigabit (1000Mb) Ethernet PHY/Transceivers (KSZ9031RN) interfaced to connectors J10 (RGMII0) and J12 (RGMII1). These Gigabit Ethernet transceivers are connected over RGMII0 and RGMII1 to the Ethernet switch block within the AM5728 processor.

The resets for the transceivers are driven low coincident with the PORz reset to the AM5728 processor. A 25-MHz clock is provided into each of the KSZ9031RN Gigabit transceivers.

2.7 USB Ports

The AM572x IDK EVM contains three USB ports. Two ports are attached to the USB peripherals USB1 and USB2 on the AM572x processor. The third port provides both XDS100V2 JTAG emulation and UART Console over the USB. This port simplifies the development environment for programmers using computers that support this capability such as Windows®-based computers.

2.7.1 Processor USB Port 1

Processor port USB1 is implemented only as a USB host (master). It supports both USB2.1 (high speed) and USB3.0 (super speed) data rates. The connector on the board, J23, is a USB3.0 Standard A-type connector. The ESD devices implemented on this USB port are the TPD2EUSB30 for the DP and DM lines and the TPD4E05U06 for the super-speed pairs.

Since processor USB port 1 supports host mode, it has the capability to drive 5.0V power on the VBUS pin. The TPS2065D load switch is controlled by the USB1_DRVVBUS pin for this purpose.

2.7.2 Processor USB Port 2

Processor port USB2 is implemented as either USB host (master) or USB device (slave). It supports only the USB2.1 (high speed and lower) data rates. The connector on the board, J45, is a USB2.1 Micro-AB connector. The ESD device implemented on this USB port is the TPD4S012.

Since processor USB port 2 supports host mode, it has the capability to drive 5.0V power on the VBUS pin. The TPS2051 load switch is controlled by the USB2_DRVVBUS pin for this purpose.

The USB2.1 standard defines different ranges of capacitance for the VBUS pin depending on whether it is host or device. Since this port can do either, the AM572x IDK EVM provides the capability to meet either requirement. The VBUS pin from the connector contains a 4.7µF capacitor that is appropriate for device mode operation. When operating in host mode, 2-pin header J50 can be shorted to add 150µF of additional capacitance to the VBUS pin. The shunt for this header is shown on the schematic as M2. It is not installed on units when shipped as we expect this port to primarily be used in device mode.

2.7.3 FTDI USB Port

The FTDI bridge device provides both XDS100V2 JTAG emulation and UART Console over the USB. Its USB connector is J19 and it is also a USB Micro-AB connector but it only operates in device (slave) mode with the FTDI bridge device. The ESD device implemented on this USB port to the FTDI bridge is the TPD2E001. Refer to [Section 2.4.4](#) for more details on this functionality.

2.8 PCIe

The AM572x processors contain two lanes of peripheral component interconnect express (PCIe). These can be implemented either as a single, dual-lane port or as two single-lane ports. The PCIe peripheral can be configured to either be a Root Complex (master) or an Endpoint (slave). The AM572x IDK EVM only implements one single-lane port as a Root Complex. The IDK EVM terminates this lane in a single-lane PCIe female connector that accepts standard PCIe Endpoint cards.

A 2-pin header, J49, is available to provide the 3V3_AUX power separate from the primary 3V3 supply. This is needed for some cards and PCIe driver configurations. The shunt, shown on the schematic as M1, should be installed when the board is received since 3V3_AUX will be needed in most cases. Please refer to the documentation for the card being installed to determine whether this shunt should remain installed.

The PERSTn reset for the connector is driven low coincident with the PORz reset to the AM5728 processor. The PERSTn reset to the connector can also be driven low by a GPIO signal from the processor. This reset can also be blocked by a GPIO signal from the processor.

A 100-MHz clock is provided separately to both the PCIe peripheral and to the PCIe connector. These clocks are buffered outputs from the same low-jitter source.

The AM572x IDK EVM is compatible with standard PCIe plug-in cards but not fully compliant with the PCIe CEM standard. It does not support hot-plug and also does not provide sufficient current on the 3.3V and 12V pins for all plug-in cards. It is currently limited to about 0.5A on each supply.

2.9 Video Input and Output

The AM572x processor family supports industrial video capture and display in addition to its industrial communications capabilities. The AM572x IDK EVM contains a camera header for attaching a module containing a camera sensor as well as support for an LCD panel display and HDMI video output.

2.9.1 Camera

The AM572x IDK EVM supports a camera daughterboard that attaches to a 24-pin (2 × 24) header, J9. The custom-designed camera module from TI, previously designed for the AM437x IDK EVM, mounts on this header. This header is connected to VIN4B on the AM5728 processor.

The 2Mp camera board contains the Darling Industrial camera module (part number DC-OVBD420AH). The camera module contains the OmniVision OV2659 camera sensor. Please contact Omnivision for the latest documentation on this sensor.

2.9.2 HDMI

The AM572x IDK EVM supports an HDMI connector driven from the HDMI port on the AM5728 processor. The connector on the board, J24, is an HDMI Standard A-type connector. It is implemented with the TPD12S016 HDMI companion chip. This companion chip provides I2C level shifting buffers, 5V load switch, and multi-channel ESD protection.

2.9.3 LCD

The AM572x IDK EVM is available with an optional LCD panel that also has a capacitive touch overlay. The video output driven for the LCD panel from the AM5728 processor is on VOUT1. A MIPI bridge device from Toshiba, TC358778, is implemented to convert from the 24-bit RGB presented on the VOUT1 pins to serial MIPI RGB streams. The LCD panel is shipped with FPC cables that plug into J16 for the MIPI video and into J17 for the touchscreen controller. Both the MIPI bridge device and the touchscreen controller are connected to the IND_I2C chain from processor port I2C1.

2.10 Industrial Interfaces

There are additional industrial interfaces implemented on the AM572x IDK EVM to help showcase the flexibility of the AM57xx line of processors.

2.10.1 Profibus

A compliant Profibus interface is implemented using the ISO1176T isolation device, transformer and TPS76650 LDO regulator. This circuit terminates to a DB9F connector, J14. This Profibus interface is driven by UART0 from the first PRU-ICSS block, PR1.

2.10.2 DCAN

The AM5728 processor contains two Controller Area Network (DCAN) interfaces. DCAN port 1 is routed out to the ISO1050 isolation device and then to the 5-pin header, J38. The R1Z-3.305HP isolated DC-DC supply provides an isolated 3.3V supply for this DCAN interface.

2.10.3 RS-485

The AM572x IDK EVM contains an RS-485 interface on 3-pin header, J39. This is enabled by the SN65HVD78D Half-Duplex RS-485 Transceiver. The transceiver controls the half-duplex communication and also provides high-voltage transient protection. This interface is attached to the SOC-level UART2 port for RX and TX data. The UART TX data line is monitored by PR2_PRU1, so that PRU code can monitor TX activity and then control the DE and REN lines into the transceiver.

2.11 User Interfaces

The AM572x IDK EVM contains GPIO expanders that provide industrial inputs and outputs to support development. The outputs contain LEDs for immediate feedback. There are also tri-color LEDs connected to GPIOs to support development.

2.11.1 Tri-color LEDs

There are 6 tri-color LEDs connected to SOC GPIO pins that can be used to support development. There is a separate GPIO assigned for each color: red, green, and yellow. Color mixing by turning on more than one GPIO at a time will not provide the expected result since the separate colors have different intensities due to the physics of the LED composition. Tri-color LEDs D16, D17, D18, and D19 are designated Industrial LEDs. Tri-color LEDs D22 and D23 are designated Status LEDs.

2.11.2 Industrial Inputs

For industrial 24v digital inputs, an SN65HVS882 Digital-input Serializer for industrial digital inputs is used to accept standard signals from the 30-pin (15 × 2) I/O Expansion Header, J37. The input values are clocked into the SPI3 port of the AM5728 processor.

2.11.3 Industrial Outputs / LEDs

I2C to 8-bit LED driver TPIC2810 is used to drive the eight Industrial output LEDs D5 to D12. The I2C interface is connected to the I2C1 port of the AM5728 processor along with the other devices on the IND_I2C bus. The eight LED driver outputs are also driven to the I/O Expansion Header, J37. All the LEDs are green in color.

2.12 Pin Use Description

2.12.1 Functional Interface Mapping

Some signals of the AM5728 device are connected to a fixed device on the EVM where it cannot be changed. However, some of the signals of the AM5728 device are connected to devices on the AM572x IDK EVM based on the profile setting.

2.12.2 GPIO Pin Mapping

The developer can enable GPIO pins individually, as needed, as output, input, or both. Most of the LVCMOS pins not currently allocated for other peripheral use can be defined as GPIO pins. [Table 2-5](#) is a compliment to the schematic and the recommended settings in the pinmux tool. Each of the defined GPIO pins are listed along with the associated pin name and ball number and mode. The last column lists the available physical pull-up (PU) or pull-down (PD) resistor attached or the recommended internal pull-up or pull-down resistor defined in the pinmux file provided for the AM572x IDK EVM.

Table 2-5. GPIO Pin Mapping

Pin Name	GPIO #	Pin #	IDK Net Name / Function	Direction	Pull Up / Pull Down
MCASP2_AXR4	GPIO1_4	D15	AM57XX_INDEETHER_LED0_YEL	Output	EXT PD
MCASP2_AXR7	GPIO1_5	A17	AM57XX_INDEETHER_LED1_YEL	Output	EXT PD
MCASP2_AXR6	GPIO2_29	B17	AM57XX_INDEETHER_LED1_GRN	Output	EXT PD
VIN1A_D6	GPIO3_10	AG6	AM57XX_STATUSLED1_RED	Output	EXT PD
VIN1A_D7	GPIO3_11	AH4	AM57XX_STATUSLED0_GRN	Output	EXT PD
VIN1A_D8	GPIO3_12	AG4	AM57XX_STATUSLED0_YEL	Output	EXT PD
VIN1A_D10	GPIO3_14	AG3	TOUCH_INT	Input	INT PU
VIN1A_D12	GPIO3_16	AF2	GPIO_AM572X_USB2_ID	Input/Output	EXT PU
VIN1A_D13	GPIO3_17	AF6	AM57XX_INDEETHER_LED3_GRN	Output	EXT PD
VIN1A_D14	GPIO3_18	AF3	AM57XX_INDEETHER_LED3_YEL	Output	EXT PD
VIN1A_D15	GPIO3_19	AF4	AM57XX_GPIO_IND_LDn	Output	EXT PU
VIN1A_D17	GPIO3_21	AE3	GPIO_VPP_PWR_EN	Output	EXT PD
VIN1A_D18	GPIO3_22	AE5	GPIO_PCIE_RSTDRVn	Output	INT PD
VIN1A_D19	GPIO3_23	AE1	GPIO_PCIE_SWRSTn	Output	INT PU
VIN1A_D22	GPIO3_26	AD2	GPIO_USB2_VBUS_DET	Input	EXT PU
VIN2A_CLK0	GPIO3_28	E1	PRU1ETH0_INTn	Input	INT PU
VIN2A_DE0	GPIO3_29	G2	PRU1ETH1_INTn	Input	INT PU
VIN2A_FLD0	GPIO3_30	H7	PRU2ETH0_INTn	Input	INT PU
VIN2A_HSYNC0	GPIO3_31	G1	PRU2ETH1_INTn	Input	INT PU
VIN1A_D5	GPIO3_9	AH5	AM57XX_INDEETHER_LED0_GRN	Output	EXT PD
VIN2A_VSYNC0	GPIO4_0	G6	AM57XX_STATUSLED0_RED	Output	EXT PD
VOUT1_FLD	GPIO4_21	B11	eMMC_RSTn	Output	EXT PU
MCASP1_ACLKR	GPIO5_0	B14	GB_ETH0_INTn	Input	EXT PU
MCASP1_FSR	GPIO5_1	J14	GB_ETH1_INTn	Input	EXT PU
MCASP1_AXR2	GPIO5_4	G13	PCIE_CRDPRESENT	Input	EXT PU
MCASP1_AXR3	GPIO5_5	J11	PCIE_WAKEn	Input	EXT PU
MCASP1_AXR4	GPIO5_6	E12	GPIO_PRU1_ETH0_RESETh	Output	EXT PU
MCASP1_AXR5	GPIO5_7	F13	GPIO_PRU1_ETH1_RESETh	Output	EXT PU
MCASP1_AXR6	GPIO5_8	C12	GPIO_PRU2_ETH0_RESETh	Output	EXT PU
MCASP1_AXR7	GPIO5_9	D12	GPIO_PRU2_ETH1_RESETh	Output	EXT PU
GPIO6_14	GPIO6_14	E21	CAM_ENn	Output	PU/PD on camera board
GPIO6_15	GPIO6_15	F20	GPIO_TOUCH_RESETh	Output	EXT PU
GPIO6_16	GPIO6_16	F21	PMIC_INT	Input	INT PU
XREF_CLK2	GPIO6_19	B26	AM57XX_INDEETHER_LED0_RED	Output	EXT PD
MCASP2_AXR5	GPIO6_7	B16	AM57XX_INDEETHER_LED1_RED	Output	EXT PD
SPI1_CS0	GPIO7_10	A24	AM57XX_INDEETHER_LED2_YEL	Output	EXT PD
SPI1_CS1	GPIO7_11	A22	AM57XX_INDEETHER_LED3_RED	Output	EXT PD
UART1_RXD	GPIO7_22	B27	AM57XX_STATUSLED1_YEL	Output	EXT PD
UART1_TXD	GPIO7_23	C26	AM57XX_STATUSLED1_GRN	Output	EXT PD
SPI1_SCLK	GPIO7_7	A25	AM572X_HAPTICS_TRIG	Output	EXT PD
SPI1_D1	GPIO7_8	F16	AM57XX_INDEETHER_LED2_GRN	Output	EXT PD
SPI1_D0	GPIO7_9	B25	AM57XX_INDEETHER_LED2_RED	Output	EXT PD

2.13 Board Connectors

This section shows the pin-outs for the connectors on the AM572x IDK EVM.

Table 2-6. Expansion Connector - J21

Pin	Signal Name	Secondary Signal Name
1	V3_3D	—
2	V5_0D	—
3	PR1_EDC_LATCH0	—
4	GPMC_CS0	—
5	PR1_EDC_SYNC0	—
6	GPMC_CS3	—
7	No Connect	—
8	GPMC_ADV_N_ALE	—
9	No Connect	AM57XX_PRU1ETH1_TXCLK
10	GPMC_OEN_REN	—
11	No Connect	AM57XX_PRU1ETH1_TXD3
12	GPMC_WEN	—
13	PR2_EDC_LATCH0	AM57XX_PRU1ETH_MDCLK
14	GPMC_BEN0	—
15	PR2_EDC_LATCH1	PRU1ETH1_TXD1
16	GPMC_BEN1	—
17	PR2_EDC_SYNC0	PRU1ETH1_RXCLK
18	No Connect	—
19	PR2_EDC_SYNC1	PRU1ETH1_RXD3
20	No Connect	—
21	No Connect	PRU1ETH1_RXD1
22	DGND	—
23	No Connect	PRU1ETH1_RXERR
24	SPI2_SCLK	—
25	SYS_RESETh	—
26	SPI2_DIN	—
27	IND_I2C_SCL	—
28	SPI2_DOUT	—
29	IND_I2C_SDA	—
30	SPI2_CS0n	—
31	AM57XX_GPMC_AD0	—
32	AM57XX_GPMC_AD8	—
33	AM57XX_GPMC_AD1	—
34	AM57XX_GPMC_AD9	—
35	AM57XX_GPMC_AD2	—
36	AM57XX_GPMC_AD10	—
37	AM57XX_GPMC_AD3	—
38	AM57XX_GPMC_AD11	—
39	DGND	—
40	DGND	—
41	CAN1_RXDF	—
42	AM57XX_GPMC_AD12	—
43	CAN1_TXDF	—
44	AM57XX_GPMC_AD13	—
45	AM57XX_PR1_UART0_TXD	—

Table 2-6. Expansion Connector - J21 (continued)

Pin	Signal Name	Secondary Signal Name
46	AM57XX_GPMC_AD14	—
47	AM57XX_PR1_UART0_RXD	—
48	AM57XX_GPMC_AD15	—
49	AM57XX_PR2_PROFI_TXEN	—
50	HDQ	—
51	AM57XX_GPMC_AD4	—
52	GPMC_WAIT0	—
53	AM57XX_GPMC_AD5	—
54	PR2_UART0_RXD	—
55	AM57XX_GPMC_AD6	—
56	PR2_UART0_TXD	—
57	AM57XX_GPMC_AD7	—
58	GPMC_CLK	—
59	DGND	—
60	DGND	—

Table 2-7. I/O Expansion Header Connector - J37

Pin	Signal Name
1	INDUS_INPUT0
2	V12_0D
3	INDUS_INPUT1
4	V12_0D
5	INDUS_INPUT2
6	V12_0D
7	INDUS_INPUT3
8	V12_0D
9	INDUS_INPUT4
10	V12_0D
11	INDUS_INPUT5
12	V12_0D
13	INDUS_INPUT6
14	V12_0D
15	INDUS_INPUT7
16	V12_0D
17	DGND
18	No Connect
19	DRAIN0
20	DRAIN1
21	DRAIN2
22	DRAIN3
23	DRAIN4
24	DRAIN5
25	DRAIN6
26	DRAIN7
27	V5_0D
28	V5_0D
29	DGND

**Table 2-7. I/O Expansion Header Connector - J37
(continued)**

Pin	Signal Name
30	DGND

Table 2-8. MicroSD Connector - J15

Pin	Pin Name	Signal Name
1	DAT2	MMC_D2
2	DAT3	MMC_D3
3	CMD	MMC_CMD
4	VDD	V3_3D
5	CLOCK	MMC_CLK
6	DGND	VSS
7	DAT0	MMC_D0
8	DAT1	MMC_D1
9	GND	DGND
10	CD	MMC1_SDCD
11	GND3	DGND
12	GND4	DGND
13	GND5	DGND
14	GND6	DGND
15	GND7	DGND
16	GND8	DGND

Table 2-9. Power Jack Connector - J1

Pin	Signal Name
1	VPWRIN_JCK
2	DGND
3	DGND

Table 2-10. Power Terminal Block Connector - J2

Pin	Signal Name
1	VPWRIN_JCK
2	DGND

Table 2-11. PRU1ETH0 RJ45 Connector - J3

Pin	Pin Name	Signal Name
1	RD+	PRU1ETHER0_RDP
2	RD-	PRU1ETHER0_RDN
3	RCT	V3_3D
4	TCT	V3_3D
5	TD+	PRU1ETHER0_TDP

Table 2-11. PRU1ETH0 RJ45 Connector - J3 (continued)

Pin	Pin Name	Signal Name
6	TD-	PRU1ETHER0_TDN
7	N/C	No connect
8	AC GND	DGND
9	YEL LED Anode	V3_3D
10	YEL LED Cathode	RXLINK
11	GRN LED Anode	V3_3D
12	GRN LED Cathode	PRU1ETH0_LINKLED
SHLD1	Shield	AGNDFRAME_PRU1ETH0
SHLD2	Shield	AGNDFRAME_PRU1ETH0

Table 2-12. PRU1ETH1 RJ45 Connector - J5

Pin	Pin Name	Signal Name
1	RD+	PRU1ETHER1_RDP
2	RD-	PRU1ETHER1_RDN
3	RCT	V3_3D
4	TCT	V3_3D
5	TD+	PRU1ETHER1_TDP
6	TD-	PRU1ETHER1_TDN
7	N/C	No connect
8	AC GND	DGND
9	YEL LED Anode	V3_3D
10	YEL LED Cathode	RXLINK
11	GRN LED Anode	V3_3D
12	GRN LED Cathode	PRU1ETH1_LINKLED
SHLD1	Shield	AGNDFRAME_PRU1ETH1
SHLD2	Shield	AGNDFRAME_PRU1ETH1

Table 2-13. PRU2ETH0 RJ45 Connector - J6

Pin	Pin Name	Signal Name
1	RD+	PRU2ETHER0_RDP
2	RD-	PRU2ETHER0_RDN
3	RCT	V3_3D
4	TCT	V3_3D
5	TD+	PRU2ETHER0_TDP
6	TD-	PRU2ETHER0_TDN
7	N/C	No connect
8	AC GND	DGND
9	YEL LED Anode	V3_3D
10	YEL LED Cathode	RXLINK
11	GRN LED Anode	V3_3D
12	GRN LED Cathode	PRU2ETH0_LINKLED
SHLD1	Shield	AGNDFRAME_PRU2ETH0
SHLD2	Shield	AGNDFRAME_PRU2ETH0

Table 2-14. PRU2ETH1 RJ45 Connector - J8

Pin	Pin Name	Signal Name
1	RD+	PRU2ETHER1_RDP
2	RD-	PRU2ETHER1_RDN
3	RCT	V3_3D
4	TCT	V3_3D
5	TD+	PRU2ETHER1_TDP
6	TD-	PRU2ETHER1_TDN
7	N/C	No connect
8	AC GND	DGND
9	YEL LED Anode	V3_3D
10	YEL LED Cathode	RXLINK
11	GRN LED Anode	V3_3D
12	GRN LED Cathode	PRU2ETH1_LINKLED
SHLD1	Shield	AGNDFRAME_PRU2ETH1
SHLD2	Shield	AGNDFRAME_PRU2ETH1

Table 2-15. PRU2ETH0 Test Header Connector - J7

Pin	Signal Name	Net Name
1	RT2_MII0_TXEN	AM57XX_PRU2ETH0_TXEN
2	RT2_MII0_RXDV	AM57XX_PRU2ETH0_RXDV
3	RT2_MII0_EDIO_DATA0	AM57XX_VIN2A_VSYNC0
4	RT2_MII0_EDIO_DATA1	AM57XX_PR1_UART0_TXD
5	DGND	—

Table 2-16. PRU2ETH1 Test Header Connector - J4

Pin	Signal Name	Net Name
1	RT2_MII1_TXEN	PRU2ETH1_TXEN
2	RT2_MII1_RXDV	PRU2ETH1_RXDV
3	RT2_MII1_EDIO_DATA0	AM57XX_VIN2A_HSYNC0
4	RT2_MII1_EDIO_DATA1	AM57XX_VIN2A_DE0
5	DGND	DGND

Table 2-17. Camera Connector - J9

Pin	Pin Name	Signal Name
1	Power	VMAIN
2	CAM1_VSYNC	DGND
3	CAM1_DATA0	AM572X_VIN4B_DATA0
4	CAM1_HSYNC	AM572X_VIN4B_HSYNC
5	CAM1_DATA1	AM572X_VIN4B_DATA1

Table 2-17. Camera Connector - J9 (continued)

Pin	Pin Name	Signal Name
6	CAM1_DATA6	AM572X_VIN4B_DATA6
7	CAM1_DATA2	AM572X_VIN4B_DATA2
8	CAM1_DATA7	AM572X_VIN4B_DATA7
9	CAM1_PCLK	AM572X_VIN4B_PCLK
10	No Connect	—
11	GND	DGND
12	GND	DGND
13	CAM1_DATA3	AM572X_VIN4B_DATA3
14	No Connect	—
15	CAM1_DATA4	AM572X_VIN4B_DATA4
16	CAM1_GIO0	PU to V3_3D
17	CAM1_WEN	AM572X_VIN4B_DATA5
18	CAM1_GIO1	CAM_ENn
19	CAM1_DATA5	AM572X_VIN4B_DE
20	CAM1_FIELD	AM572X_VIN4B_FLD
21	GND	DGND
22	I2C_SCL	IND_I2C_SCL
23	Clock	20.000 MHz Osc Out
24	I2C_SDA	IND_I2C_SDA

Table 2-18. GigE RJ45 Connector - J10

Pin	Pin Name	Signal Name
1	CH-GND	DGND
2	VCC	No connect
3	MX3+	ETHER0_D3P
4	MX3-	ETHER0_D3N
5	MX2+	ETHER0_D2P
6	MX2-	ETHER0_D2N
7	MX1+	ETHER0_D1P
8	MX1-	ETHER0_D1N
9	MX0+	ETHER0_D0P
10	MX0-	ETHER0_D0N
11	RT GRN Anode	PU to PHY0_LED_ACTn
12	RT YEL Anode	DGND
13	LEFT GRN Anode	DGND
14	LEFT YEL Anode	PU to PHY0_LED_LINKn
SHLD1	Shield	AGND_GBETH0
SHLD2	Shield	AGND_GBETH0

Table 2-19. GigE RJ45 Connector - J12

Pin	Pin Name	Signal Name
1	CH-GND	DGND
2	VCC	No connect
3	MX3+	ETHER1_D3P
4	MX3-	ETHER1_D3N

Table 2-19. GigE RJ45 Connector - J12 (continued)

Pin	Pin Name	Signal Name
5	MX2+	ETHER1_D2P
6	MX2-	ETHER1_D2N
7	MX1+	ETHER1_D1P
8	MX1-	ETHER1_D1N
9	MX0+	ETHER1_D0P
10	MX0-	ETHER1_D0N
11	RT GRN Anode	PU to PHY1_LED_ACTn
12	RT YEL Anode	DGND
13	LEFT GRN Anode	DGND
14	LEFT YEL Anode	PU to PHY1_LED_LINKn
SHLD1	Shield	AGND_GBETH1
SHLD2	Shield	AGND_GBETH1

Table 2-20. LCD Module FFC Connector - J16

Pin	Pin Name	Signal Name
1	—	No Connect
2	—	No Connect
3	VCC	V3_7LCD
4	VCC	V3_7LCD
5	VCC	V3_7LCD
6	—	No Connect
7	GND	DGND
8	MIPI_LN3_N	LCD_MIPI3N
9	MIPI_LN3_P	LCD_MIPI3P
10	GND	DGND
11	MIPI_LN2_N	LCD_MIPI2N
12	MIPI_LN2_P	LCD_MIPI2P
13	GND	DGND
14	MIPI_LN1_N	LCD_MIPI1N
15	MIPI_LN1_P	LCD_MIPI1P
16	GND	DGND
17	MIPI_LN0_N	LCD_MIPI0N
18	MIPI_LN0_P	LCD_MIPI0P
19	GND	DGND
20	MIPI_CLK_N	LCD_CLKN
21	MIPI_CLK_P	LCD_CLKP
22	GND	DGND
23	LED_CATHODE	VLED-
24	LED_CATHODE	VLED-
25	LED_CATHODE	VLED-
26	LED_CATHODE	VLED-
27	LED_CATHODE	VLED-
28	LED_CATHODE	VLED-
29	LED Anode Supply	VLED+
30	LED Anode Supply	VLED+
31	—	No Connect
32	—	No Connect

Table 2-21. Touchscreen Controller FFC Connector - J17

Pin	Pin Name	Signal Name
1	SDA	IND_I2C_SDA
2	SCL	IND_I2C_SCL
3	TSC_RESETh	GPIO_TOUCH_RESETh
4	TSC_INT	TOUCH_INT
5	V+	V3_3D
6	GND	DGND

Table 2-22. HDMI Standard A-type Connector - J24

Pin	Pin Name	Signal Name
1	DAT2+	HDMI_TX2+
2	DAT2_S	DGND
3	DAT2-	HDMI_TX2-
4	DAT1+	HDMI_TX1+
5	DAT1_S	DGND
6	DAT1-	HDMI_TX1-
7	DAT0+	HDMI_TX0+
8	DAT0_S	DGND
9	DAT0-	HDMI_TX0-
10	CLK+	HDMI_CLK+
11	CLK_S	DGND
12	CLK-	HDMI_CLK-
13	CEC	HDMICONN_CEC
14	NC	No Connect
15	SCL	HDMICONN_I2CSCL
16	SDA	HDMICONN_I2CSDA
17	DDC/CEC GND	DGND
18	+5V	V5_0HDMICONN
19	HPLG	HDMICONN_HPLG
MTG1	Shield	DGND
MTG2	Shield	DGND
MTG3	Shield	DGND
MTG4	Shield	DGND

Table 2-23. MIPI-60 JTAG Connector - J18

Pin	Pin Name	Signal Name
1	VREF_DBG	PU to V3_3D
2	TMS	JTAG_TMS
3	TCK	JTAG_TCK
4	TDO	JTAG_TDO
5	TDI	JTAG_TDI
6	RESETn	EMU_RSTn
7	RTCK	AM57XX_RTCK
8	TRSTPD	JTAG_TRSTn
9	TRSTn	No Connect
10	EXTE	No Connect
11	EXTF	No Connect
12	VREF_TR	PU to V3_3D
13	TR_CLK0	EMU2
14	TR_CLK1	No Connect
15	TGT_DETECT	DGND
16	GND	DGND
17	TRD0.0	EMU3
18	TRD1.0	No Connect
19	TRD0.1	JTAG_EMU0

Table 2-23. MIPI-60 JTAG Connector - J18 (continued)

Pin	Pin Name	Signal Name
20	TRD1.1	No Connect
21	TRD0.2	JTAG_EMU1
22	TRD1.2	No Connect
23	TRD0.3	EMU4
24	TRD1.3	No Connect
25	TRD0.4	EMU5
26	TRD1.4	No Connect
27	TRD0.5	EMU6
28	TRD1.5	No Connect
29	TRD0.6	EMU7
30	TRD1.6	No Connect
31	TRD0.7	EMU8
32	TRD1.7	No Connect
33	TRD0.8	EMU9
34	TRD1.8	No Connect
35	TRD0.9	EMU10
36	TRD1.9	No Connect
37	TRD3.0	EMU11
38	TRD2.0	No Connect
39	TRD3.1	EMU12
40	TRD2.1	No Connect
41	TRD3.2	EMU13
42	TRD2.2	No Connect
43	TRD3.3	EMU14
44	TRD2.3	No Connect
45	TRD3.4	EMU15
46	TRD2.4	No Connect
47	TRD3.5	EMU16
48	TRD2.5	No Connect
49	TRD3.6	EMU17
50	TRD2.6	No Connect
51	TRD3.7	EMU18
52	TRD2.7	No Connect
53	TRD3.8	EMU19
54	TRD2.8	No Connect
55	TRD3.9	No Connect
56	TRD2.9	No Connect
57	GND	DGND
58	GND	DGND
59	TR_CLK3	No Connect
60	TR_CLK2	No Connect
61	GND	DGND
62	GND	DGND
63	GND	DGND
64	GND	DGND

Table 2-24. JTAG USB Micro-AB Connector - J19

Pin	Pin Name	Signal Name
1	VBUS	VUSB_JTAG
2	DM	EMU_USB_DM
3	DP	EMU_USB_DP
4	ID	No Connect
5	GND	DGND
S1	S1	GNDUSBJ
S2	S2	GNDUSBJ
S3	S3	GNDUSBJ
S4	S4	GNDUSBJ

Table 2-25. USB Port 1 USB3.0 Standard A-type Connector - J23

Pin	Pin Name	Signal Name
1	VBUS	VUSB_VBUS1
2	DM	USB1_CONN_DM
3	DP	USB1_CONN_DP
4	GND	DGND
5	STDA_SSRX-	USB1_3_0_STDA_SSRX-
6	STDA_SSRX+	USB1_3_0_STDA_SSRX+
7	GND_DRAIN	DGND
8	STDA_SSTX-	USB1_3_0_STDA_SSTX-
9	STDA_SSTX+	USB1_3_0_STDA_SSTX+
S1	S1	GNDUSB1
S2	S2	GNDUSB1

Table 2-26. USB Port 2 USB2.1 Micro-AB Connector - J45

Pin	Pin Name	Signal Name
1	VBUS	VUSB_VBUS2
2	DM	USB2_CONN_DM
3	DP	USB2_CONN_DP
4	ID	USB2_ID
5	GND	DGND
S1	S1	GNDUSB2
S2	S2	GNDUSB2
S3	S3	GNDUSB2
S4	S4	GNDUSB2

Table 2-27. CAN Header Connector - J38

Pin	Signal Name
1	VCAN1
2	CAN1_H
3	CAN1_L

Table 2-27. CAN Header Connector - J38 (continued)

Pin	Signal Name
4	GND_CAN1
5	No Connect

Table 2-28. Profibus DB9F Connector - J14

Pin	Signal Name
1	No Connect
2	No Connect
3	PROFIBUS_A
4	No Connect
5	GND_PROFI
6	VPROFI
7	No Connect
8	PROFIBUS_B
9	No Connect

Table 2-29. RS-485 Header Connector - J39

Pin	Signal Name
1	RS485_A
2	RS485_B
3	DGND

Table 2-30. PCIe Connector – J22

Pin	Pin Name	Signal Name
B1	+12 V	V12_0D
B2	+12 V	V12_0D
B3	+12 V	V12_0D
B4	Ground	DGND
B5	SMCLK	PCIE_SMB_CLK
B6	SMDAT	PCIE_SMB_DATA
B7	Ground	DGND
B8	+3.3V	V3_3D
B9	TRST#	PCIE_TRSTn
B10	+3.3V AUX	V3_3AUX_PCIE
B11	WAKE#	PCIE_WAKEn
B12	CLKREQ#	No Connect
B13	Ground	DGND
B14	HSOp(0)	PCIECONN_PETp0
B15	HSOn(0)	PCIECONN_PETn0
B16	Ground	DGND
B17	PRSNT2#	DGND
B18	Ground	DGND

Table 2-30. PCIe Connector – J22 (continued)

Pin	Pin Name	Signal Name
A1	PRSNT1#	PCIE_CRDPRESENT
A2	+12 V	V12_0D
A3	+12 V	V12_0D
A4	Ground	DGND
A5	TCK	PD to DGND
A6	TDI	PU to V3_3D
A7	TDO	TP20
A8	TMS	PU to V3_3D
A9	+3.3V	V3_3D
A10	+3.3V	V3_3D
A11	PERST#	PCIE_PERSTn
A12	Ground	DGND
A13	REFCLK+	PCIE_REFCLKP
A14	REFCLK-	PCIE_REFCLKN
A15	Ground	DGND
A16	HSIp(0)	PCIE_PERp0
A17	HSIn(0)	PCIE_PERn0
A18	Ground	DGND

2.14 EVM Important Notice

Refer to the [STANDARD TERMS AND CONDITIONS FOR EVALUATION MODULES \(SSZZ027\)](#).

3 Known Deficiencies in AM5724x IDK EVM

3.1 Power solution not sufficient for full PCIe plug-in card compliance

The AM572x IDK EVM supports compatibility to PCIe x1 plug-in cards. It is not compliant with the PCIe Card Electro-Mechanical (CEM) specification. Specifically, the board does not provide the recommended power per the CEM. It provides up to 0.5A of current on the 3.3V/3.3V_AUX input pins and up to 0.5A on the 12V input pins. Also, the root complex design implemented does not support hot plug-in of cards.

3.2 Early versions of the AM572x IDK EVM not installed with SOC devices rated for the full industrial temperature range

3.3 AM572x IDK EVM does not support eMMC HS200 mode

The interface voltage for the eMMC is fixed at 3.3V in all modes of operation. This prevents support of HS200 which requires a transition to 1.8V. The AM572x IDK EVM does support this voltage shift for the SDCARD attached to the MMC1 port. The MMC1 port is on VDDSHV8 supply that is attached to the LDO1 PMIC output that supports this voltage shift for higher speed modes. The eMMC is attached to the VDDSHV11 supply fixed at 3.3V. Board designs that require HS200 support for eMMC would need a solution to transition from 3.3V to 1.8V under software control.

3.4 PCIe PERSTn line not in proper state at start-up

The board does not contain pull-up or pull-down resistors to allow this line to be pulled-high at start-up. This can cause PCIe link training to fail. Future software releases need to properly control the GPIO output pins to enable this correctly at start-up.

3.5 EDIO connectors J4 and J7 should support real-time debugging for both PRU1 and PRU2

The pins chosen provide visibility to the PRU2 MII0 and MII1 ports and PRU1 EDIO ports.

3.6 HDQ implementation not correct

HDQ was intended to be attached to the Expansion Connector. Since this pin is multiplexed with XREF_CLK3/CLKOUT3 used with the Camera connector, the clock options implemented for the camera connector prevent use of HDQ without addition of a wire. This can be enabled by adding a wire between the open pads of R905 and R300.

3.7 Removing the power plug and inserting it again while the power supply is energized may cause damage

Removing the power plug and inserting it again while the power supply is energized may damage the AM572x IDK EVM and/or other devices attached to the board such as emulators that provide an alternate path to ground. Removal of AC power from the external power supply is a safer method, if required. It is also recommended that the external power supply have the common return bonded to earth ground. If this is not possible, a separate connection from the board ground to earth ground may need to be provided. Test fixtures that repeatedly cycle main power on and off should have the board ground bonded to earth ground at all times during this testing.

3.8 Software shutdown of PMIC not operational

The PMIC is implemented to support PORz generation whenever any reset is initiated within the AM5728 SOC. This is enabled by pulling PMIC BOOT1 to VRTC. This has the side effect of requiring that PMIC GPIO7/POWERHOLD also be pulled high. This results in an “always on” design that cannot be shut-off by software. An external PORz pulse generator like that implemented on the X15 GP EVM would need to be used to enable this feature. Please refer to i862 in the errata document for more information.

3.9 PMIC implementation does not support required SOC shut-down sequence

The AM5728 SOC requires that its supplies are sequenced on and off in the correct sequence to maintain the reliability as stated in the [AM572x Sitara Processors Silicon Revision 2.0 Data Manual \(SPRS982\)](#). The PMIC can enforce this start-up and also the shut-down sequence if the PMIC RESET_IN is driven low at least 1.1ms before the main supply to the PMIC collapses. However, the AM572x IDK EVM design does not contain a circuit for this. Please refer to the AM571 IDK EVM design (v1.3 or later) for an example of the required circuitry.

3.10 USB port providing UART console and XDS100 emulation not isolated from EVM board supplies

Whenever the EVM power supplies are cycled, the USB connection supporting the UART console and XDS100 emulation also drops. Since this port takes time to enumerate after power is restored, initial console output can be lost. Also, this results in power leakage from the USB VBUS back into the EVM when it is not powered. Please refer to the AM571 IDK EVM design (v1.3 or later) for an example of the required circuitry that will allow the USB bridge to remain properly powered and isolated from the EVM to prevent these negative affects.

3.11 Need 47- μ F capacitor at camera header

Some camera video input instability has been seen. The solution for this is addition of a 47 μ F capacitor at the supply pin for the camera header. This has been implemented on the AM571x IDK EVM v1.3 and later.

3.12 Decoupling capacitors do not reflect AM572x PDN recommendations

Decoupling capacitors do not reflect AM572x PDN recommendations per [AM572x GP EVM Power Simulations Application Report \(SPRABY8\)](#)

These were corrected in the latest version of the AM571x IDK EVM. Please refer to the AM571 IDK EVM design (v1.3 or later) for an example of the required circuitry.

3.13 CCS System Reset fails

Warm reset and emulation reset events configured for warm reset cause the Texas Instruments Code Composer Studio™ (CCS) integrated development environment (IDE) to issue an error message. This is due to the reset erratum that requires all resets to trigger a PORz low event. Since this is not expected by CCS when it initiates a warm reset, it loses its context and issues an error. Newer versions of CCS handle this event better but an error message will always be generated.

3.14 AM572x IDK EVM design contains 2 clamp circuits that may not be necessary

During early investigation of power shut-down sequencing, it was determined that clamps were required on every 3.3V supply to the dual-voltage I/O cell supplies (VDDSHVx). This would enforce the requirement shown in Figure 5-3 of the [AM572x Sitara Processors Silicon Revision 2.0 Data Manual \(SPRS982\)](#) that states that the 3.3V supply inputs must never be more than 2.0V above the VDD18V supply, even during ramping up or ramping down. The AM572x IDK EVM design contains these clamp circuits on both V3_3D, that powers almost all VDDSHVx supplies, and VSDMMC, that powers VDDSHV8 used with the SDCARD on MMC1. Later it was determined that the only method to maintain device reliability was to fully enforce the supply sequence requirements shown in Figures 5-1 and 5-2 of the [AM572x Sitara Processors Silicon Revision 2.0 Data Manual \(SPRS982\)](#). The companion PMIC, TPS6590377, was enhanced to provide a shortened shut-down sequence that enforces the DM requirements in a time period (~1ms) that the PMIC input can hold up the supplies. The PMIC also has supply discharge resistors to pull down the supplies quickly when they are turning off. These 2 capabilities in the companion PMIC make the clamp circuits superfluous. However, designs that use REGEN1 to power the VDDSHVx supplies through a power switch will still need the clamp circuit. The power switches available do not discharge the supplies quick enough.

3.15 Crystal connected to osc0 needs to have 50 ppm or better long term accuracy

The crystal connected to osc0 needs to have 50ppm or better long term accuracy since it generates clocks used for Ethernet interfaces. The current crystal has 30ppm accuracy and 50ppm temperature variation for a combined tolerance of 80ppm. It also has aging of 2ppm per year.

3.16 Software must program the CDCE913 for 0-pf load capacitance

Software must program the CDCE913 for 0pf load capacitance to allow crystals to operate at their target frequency. Crystal load capacitors can be added to the oscillator circuit to allow the generated clock to output at the required nominal frequency so that this programming is not required. The default capacitance within the CDCE913 is 10pF so the capacitors C172, C173, C193, and C194 should be 8pF. Please refer to the [CDCE\(L\)913: Flexible Low Power LVCMOS Clock Generator With SSC Support for EMI Reduction Data Manual \(SCAS849\)](#) for more information. Also note that these clock generators are used to drive the Ethernet circuitry, so the same crystal accuracy requirement from [Section 3.15](#) applies to these crystals as well.

3.17 Protection diode D2 should be rated for 5 V

Protection diode D2 has the wrong value. It is meant to conduct current, if a voltage too large is connected to the IDK. This current surge should blow the fuse before ICs are damaged. The current part SMCJ26CA is rated for 26 V. It should be replaced with SMCJ5.0A that is rated to protect a 5-V input power supply circuit.

3.18 PHY address LSB for U9 and U15 can be latched incorrectly

The PHY address LSB for U9 and U15 gets determined by the signal level at the PHY's COL pin during reset release. The PHY has a pull-down resistor connected to this pin to enable latching the value of 0. Unfortunately, this pin is also connected to one of the RJ-45 connector LEDs that pulls the signal to an undefined voltage of about 1.4V during the reset time. Therefore, the PHY address can incorrectly latch a value of 1. The LED circuit should be configured for active-high indication and the connections to the LED reversed with the cathode connected to ground. This allows the LSB of the address to be properly latched. Please refer to Section 6 of the [TLK1XX Design and Layout Guide Application Report \(SLVA531\)](#) for more information. The current software workaround programs the RXLINK pin with a pull-down resistor and then pulses the PHY reset from a GPIO, to cause it to latch the PHY address correctly.

3.19 3.3-V clamp circuit needs more margin

The 3.3-V clamp circuit is tuned too close such that if the 1.8-V supply is 5% low and the 3.3-V supply is 5% high, the clamp will begin conducting. Replacing R897 with a 24.3-K Ω resistor provides the proper tolerance, so the circuit starts conducting at a delta voltage of 1.75 V rather than the current setting of 1.5 V.

3.20 Current PMIC does not provide the mandated power down sequence

The current PMIC does not provide the mandated power down sequence as shown in the [AM572x Sitara Processors Silicon Revision 2.0 Data Manual \(SPRS982\)](#). Production IDK EVMs contain the TPS6590377 PMIC,

which powers off the DDR supply at the wrong time. The default programming has been corrected in the TPS6590379 PMIC. This part will be used for future builds.

3.21 PMIC OSC16MCAP pin mistakenly grounded

The OSC16MCAP pin on the TPS659037x PMIC should be connected to a 2.2- μ F capacitor to ground. Unfortunately, all versions of this IDK EVM have this pin connected directly to ground. Although there are many IDK EVMs in use, connecting the OSC16MCAP pin directly to ground may damage the TPS659037x PMIC. Operation may become erratic or it may fail completely. Designs that copied this design mistake must be corrected.

4 Revision History

Changes from Revision E (September 2019) to Revision F (October 2025)	Page
• Added HDMI trademark information.....	2

STANDARD TERMS FOR EVALUATION MODULES

1. *Delivery:* TI delivers TI evaluation boards, kits, or modules, including any accompanying demonstration software, components, and/or documentation which may be provided together or separately (collectively, an "EVM" or "EVMs") to the User ("User") in accordance with the terms set forth herein. User's acceptance of the EVM is expressly subject to the following terms.
 - 1.1 EVMs are intended solely for product or software developers for use in a research and development setting to facilitate feasibility evaluation, experimentation, or scientific analysis of TI semiconductor products. EVMs have no direct function and are not finished products. EVMs shall not be directly or indirectly assembled as a part or subassembly in any finished product. For clarification, any software or software tools provided with the EVM ("Software") shall not be subject to the terms and conditions set forth herein but rather shall be subject to the applicable terms that accompany such Software
 - 1.2 EVMs are not intended for consumer or household use. EVMs may not be sold, sublicensed, leased, rented, loaned, assigned, or otherwise distributed for commercial purposes by Users, in whole or in part, or used in any finished product or production system.
2. *Limited Warranty and Related Remedies/Disclaimers:*
 - 2.1 These terms do not apply to Software. The warranty, if any, for Software is covered in the applicable Software License Agreement.
 - 2.2 TI warrants that the TI EVM will conform to TI's published specifications for ninety (90) days after the date TI delivers such EVM to User. Notwithstanding the foregoing, TI shall not be liable for a nonconforming EVM if (a) the nonconformity was caused by neglect, misuse or mistreatment by an entity other than TI, including improper installation or testing, or for any EVMs that have been altered or modified in any way by an entity other than TI, (b) the nonconformity resulted from User's design, specifications or instructions for such EVMs or improper system design, or (c) User has not paid on time. Testing and other quality control techniques are used to the extent TI deems necessary. TI does not test all parameters of each EVM. User's claims against TI under this Section 2 are void if User fails to notify TI of any apparent defects in the EVMs within ten (10) business days after delivery, or of any hidden defects with ten (10) business days after the defect has been detected.
 - 2.3 TI's sole liability shall be at its option to repair or replace EVMs that fail to conform to the warranty set forth above, or credit User's account for such EVM. TI's liability under this warranty shall be limited to EVMs that are returned during the warranty period to the address designated by TI and that are determined by TI not to conform to such warranty. If TI elects to repair or replace such EVM, TI shall have a reasonable time to repair such EVM or provide replacements. Repaired EVMs shall be warranted for the remainder of the original warranty period. Replaced EVMs shall be warranted for a new full ninety (90) day warranty period.

WARNING

Evaluation Kits are intended solely for use by technically qualified, professional electronics experts who are familiar with the dangers and application risks associated with handling electrical mechanical components, systems, and subsystems.

User shall operate the Evaluation Kit within TI's recommended guidelines and any applicable legal or environmental requirements as well as reasonable and customary safeguards. Failure to set up and/or operate the Evaluation Kit within TI's recommended guidelines may result in personal injury or death or property damage. Proper set up entails following TI's instructions for electrical ratings of interface circuits such as input, output and electrical loads.

NOTE:

EXPOSURE TO ELECTROSTATIC DISCHARGE (ESD) MAY CAUSE DEGRADATION OR FAILURE OF THE EVALUATION KIT; TI RECOMMENDS STORAGE OF THE EVALUATION KIT IN A PROTECTIVE ESD BAG.

3 Regulatory Notices:

3.1 United States

3.1.1 Notice applicable to EVMs not FCC-Approved:

FCC NOTICE: This kit is designed to allow product developers to evaluate electronic components, circuitry, or software associated with the kit to determine whether to incorporate such items in a finished product and software developers to write software applications for use with the end product. This kit is not a finished product and when assembled may not be resold or otherwise marketed unless all required FCC equipment authorizations are first obtained. Operation is subject to the condition that this product not cause harmful interference to licensed radio stations and that this product accept harmful interference. Unless the assembled kit is designed to operate under part 15, part 18 or part 95 of this chapter, the operator of the kit must operate under the authority of an FCC license holder or must secure an experimental authorization under part 5 of this chapter.

3.1.2 For EVMs annotated as FCC – FEDERAL COMMUNICATIONS COMMISSION Part 15 Compliant:

CAUTION

This device complies with part 15 of the FCC Rules. Operation is subject to the following two conditions: (1) This device may not cause harmful interference, and (2) this device must accept any interference received, including interference that may cause undesired operation.

Changes or modifications not expressly approved by the party responsible for compliance could void the user's authority to operate the equipment.

FCC Interference Statement for Class A EVM devices

NOTE: This equipment has been tested and found to comply with the limits for a Class A digital device, pursuant to part 15 of the FCC Rules. These limits are designed to provide reasonable protection against harmful interference when the equipment is operated in a commercial environment. This equipment generates, uses, and can radiate radio frequency energy and, if not installed and used in accordance with the instruction manual, may cause harmful interference to radio communications. Operation of this equipment in a residential area is likely to cause harmful interference in which case the user will be required to correct the interference at his own expense.

FCC Interference Statement for Class B EVM devices

NOTE: This equipment has been tested and found to comply with the limits for a Class B digital device, pursuant to part 15 of the FCC Rules. These limits are designed to provide reasonable protection against harmful interference in a residential installation. This equipment generates, uses and can radiate radio frequency energy and, if not installed and used in accordance with the instructions, may cause harmful interference to radio communications. However, there is no guarantee that interference will not occur in a particular installation. If this equipment does cause harmful interference to radio or television reception, which can be determined by turning the equipment off and on, the user is encouraged to try to correct the interference by one or more of the following measures:

- Reorient or relocate the receiving antenna.
- Increase the separation between the equipment and receiver.
- Connect the equipment into an outlet on a circuit different from that to which the receiver is connected.
- Consult the dealer or an experienced radio/TV technician for help.

3.2 Canada

3.2.1 For EVMs issued with an Industry Canada Certificate of Conformance to RSS-210 or RSS-247

Concerning EVMs Including Radio Transmitters:

This device complies with Industry Canada license-exempt RSSs. Operation is subject to the following two conditions:

(1) this device may not cause interference, and (2) this device must accept any interference, including interference that may cause undesired operation of the device.

Concernant les EVMs avec appareils radio:

Le présent appareil est conforme aux CNR d'Industrie Canada applicables aux appareils radio exempts de licence. L'exploitation est autorisée aux deux conditions suivantes: (1) l'appareil ne doit pas produire de brouillage, et (2) l'utilisateur de l'appareil doit accepter tout brouillage radioélectrique subi, même si le brouillage est susceptible d'en compromettre le fonctionnement.

Concerning EVMs Including Detachable Antennas:

Under Industry Canada regulations, this radio transmitter may only operate using an antenna of a type and maximum (or lesser) gain approved for the transmitter by Industry Canada. To reduce potential radio interference to other users, the antenna type and its gain should be so chosen that the equivalent isotropically radiated power (e.i.r.p.) is not more than that necessary for successful communication. This radio transmitter has been approved by Industry Canada to operate with the antenna types listed in the user guide with the maximum permissible gain and required antenna impedance for each antenna type indicated. Antenna types not included in this list, having a gain greater than the maximum gain indicated for that type, are strictly prohibited for use with this device.

Concernant les EVMs avec antennes détachables

Conformément à la réglementation d'Industrie Canada, le présent émetteur radio peut fonctionner avec une antenne d'un type et d'un gain maximal (ou inférieur) approuvé pour l'émetteur par Industrie Canada. Dans le but de réduire les risques de brouillage radioélectrique à l'intention des autres utilisateurs, il faut choisir le type d'antenne et son gain de sorte que la puissance isotrope rayonnée équivalente (p.i.r.e.) ne dépasse pas l'intensité nécessaire à l'établissement d'une communication satisfaisante. Le présent émetteur radio a été approuvé par Industrie Canada pour fonctionner avec les types d'antenne énumérés dans le manuel d'usage et ayant un gain admissible maximal et l'impédance requise pour chaque type d'antenne. Les types d'antenne non inclus dans cette liste, ou dont le gain est supérieur au gain maximal indiqué, sont strictement interdits pour l'exploitation de l'émetteur.

3.3 Japan

3.3.1 *Notice for EVMs delivered in Japan:* Please see http://www.tij.co.jp/lstds/ti_ja/general/eStore/notice_01.page 日本国内に輸入される評価用キット、ボードについては、次のところをご覧ください。

<https://www.ti.com/ja-jp/legal/notice-for-evaluation-kits-delivered-in-japan.html>

3.3.2 *Notice for Users of EVMs Considered "Radio Frequency Products" in Japan:* EVMs entering Japan may not be certified by TI as conforming to Technical Regulations of Radio Law of Japan.

If User uses EVMs in Japan, not certified to Technical Regulations of Radio Law of Japan, User is required to follow the instructions set forth by Radio Law of Japan, which includes, but is not limited to, the instructions below with respect to EVMs (which for the avoidance of doubt are stated strictly for convenience and should be verified by User):

1. Use EVMs in a shielded room or any other test facility as defined in the notification #173 issued by Ministry of Internal Affairs and Communications on March 28, 2006, based on Sub-section 1.1 of Article 6 of the Ministry's Rule for Enforcement of Radio Law of Japan,
2. Use EVMs only after User obtains the license of Test Radio Station as provided in Radio Law of Japan with respect to EVMs, or
3. Use of EVMs only after User obtains the Technical Regulations Conformity Certification as provided in Radio Law of Japan with respect to EVMs. Also, do not transfer EVMs, unless User gives the same notice above to the transferee. Please note that if User does not follow the instructions above, User will be subject to penalties of Radio Law of Japan.

【無線電波を送信する製品の開発キットをお使いになる際の注意事項】 開発キットの中には技術基準適合証明を受けていないものがあります。技術適合証明を受けていないものご使用に際しては、電波法遵守のため、以下のいずれかの措置を取っていただく必要がありますのでご注意ください。

1. 電波法施行規則第6条第1項第1号に基づく平成18年3月28日総務省告示第173号で定められた電波暗室等の試験設備でご使用いただく。
2. 実験局の免許を取得後ご使用いただく。
3. 技術基準適合証明を取得後ご使用いただく。

なお、本製品は、上記の「ご使用にあたっての注意」を譲渡先、移転先に通知しない限り、譲渡、移転できないものとします。

上記を遵守頂けない場合は、電波法の罰則が適用される可能性があることをご留意ください。日本テキサス・イ

ンスツルメンツ株式会社

東京都新宿区西新宿 6 丁目 2 4 番 1 号

西新宿三井ビル

3.3.3 *Notice for EVMs for Power Line Communication:* Please see http://www.tij.co.jp/lstds/ti_ja/general/eStore/notice_02.page

電力線搬送波通信についての開発キットをお使いになる際の注意事項については、次のところをご覧ください。 <https://www.ti.com/ja-jp/legal/notice-for-evaluation-kits-for-power-line-communication.html>

3.4 European Union

3.4.1 *For EVMs subject to EU Directive 2014/30/EU (Electromagnetic Compatibility Directive):*

This is a class A product intended for use in environments other than domestic environments that are connected to a low-voltage power-supply network that supplies buildings used for domestic purposes. In a domestic environment this product may cause radio interference in which case the user may be required to take adequate measures.

-
4. *EVM Use Restrictions and Warnings:*
 - 4.1 EVMS ARE NOT FOR USE IN FUNCTIONAL SAFETY AND/OR SAFETY CRITICAL EVALUATIONS, INCLUDING BUT NOT LIMITED TO EVALUATIONS OF LIFE SUPPORT APPLICATIONS.
 - 4.2 User must read and apply the user guide and other available documentation provided by TI regarding the EVM prior to handling or using the EVM, including without limitation any warning or restriction notices. The notices contain important safety information related to, for example, temperatures and voltages.
 - 4.3 *Safety-Related Warnings and Restrictions:*
 - 4.3.1 User shall operate the EVM within TI's recommended specifications and environmental considerations stated in the user guide, other available documentation provided by TI, and any other applicable requirements and employ reasonable and customary safeguards. Exceeding the specified performance ratings and specifications (including but not limited to input and output voltage, current, power, and environmental ranges) for the EVM may cause personal injury or death, or property damage. If there are questions concerning performance ratings and specifications, User should contact a TI field representative prior to connecting interface electronics including input power and intended loads. Any loads applied outside of the specified output range may also result in unintended and/or inaccurate operation and/or possible permanent damage to the EVM and/or interface electronics. Please consult the EVM user guide prior to connecting any load to the EVM output. If there is uncertainty as to the load specification, please contact a TI field representative. During normal operation, even with the inputs and outputs kept within the specified allowable ranges, some circuit components may have elevated case temperatures. These components include but are not limited to linear regulators, switching transistors, pass transistors, current sense resistors, and heat sinks, which can be identified using the information in the associated documentation. When working with the EVM, please be aware that the EVM may become very warm.
 - 4.3.2 EVMs are intended solely for use by technically qualified, professional electronics experts who are familiar with the dangers and application risks associated with handling electrical mechanical components, systems, and subsystems. User assumes all responsibility and liability for proper and safe handling and use of the EVM by User or its employees, affiliates, contractors or designees. User assumes all responsibility and liability to ensure that any interfaces (electronic and/or mechanical) between the EVM and any human body are designed with suitable isolation and means to safely limit accessible leakage currents to minimize the risk of electrical shock hazard. User assumes all responsibility and liability for any improper or unsafe handling or use of the EVM by User or its employees, affiliates, contractors or designees.
 - 4.4 User assumes all responsibility and liability to determine whether the EVM is subject to any applicable international, federal, state, or local laws and regulations related to User's handling and use of the EVM and, if applicable, User assumes all responsibility and liability for compliance in all respects with such laws and regulations. User assumes all responsibility and liability for proper disposal and recycling of the EVM consistent with all applicable international, federal, state, and local requirements.
 5. *Accuracy of Information:* To the extent TI provides information on the availability and function of EVMs, TI attempts to be as accurate as possible. However, TI does not warrant the accuracy of EVM descriptions, EVM availability or other information on its websites as accurate, complete, reliable, current, or error-free.
 6. *Disclaimers:*
 - 6.1 EXCEPT AS SET FORTH ABOVE, EVMS AND ANY MATERIALS PROVIDED WITH THE EVM (INCLUDING, BUT NOT LIMITED TO, REFERENCE DESIGNS AND THE DESIGN OF THE EVM ITSELF) ARE PROVIDED "AS IS" AND "WITH ALL FAULTS." TI DISCLAIMS ALL OTHER WARRANTIES, EXPRESS OR IMPLIED, REGARDING SUCH ITEMS, INCLUDING BUT NOT LIMITED TO ANY EPIDEMIC FAILURE WARRANTY OR IMPLIED WARRANTIES OF MERCHANTABILITY OR FITNESS FOR A PARTICULAR PURPOSE OR NON-INFRINGEMENT OF ANY THIRD PARTY PATENTS, COPYRIGHTS, TRADE SECRETS OR OTHER INTELLECTUAL PROPERTY RIGHTS.
 - 6.2 EXCEPT FOR THE LIMITED RIGHT TO USE THE EVM SET FORTH HEREIN, NOTHING IN THESE TERMS SHALL BE CONSTRUED AS GRANTING OR CONFERRING ANY RIGHTS BY LICENSE, PATENT, OR ANY OTHER INDUSTRIAL OR INTELLECTUAL PROPERTY RIGHT OF TI, ITS SUPPLIERS/LICENSORS OR ANY OTHER THIRD PARTY, TO USE THE EVM IN ANY FINISHED END-USER OR READY-TO-USE FINAL PRODUCT, OR FOR ANY INVENTION, DISCOVERY OR IMPROVEMENT, REGARDLESS OF WHEN MADE, CONCEIVED OR ACQUIRED.
 7. *USER'S INDEMNITY OBLIGATIONS AND REPRESENTATIONS.* USER WILL DEFEND, INDEMNIFY AND HOLD TI, ITS LICENSORS AND THEIR REPRESENTATIVES HARMLESS FROM AND AGAINST ANY AND ALL CLAIMS, DAMAGES, LOSSES, EXPENSES, COSTS AND LIABILITIES (COLLECTIVELY, "CLAIMS") ARISING OUT OF OR IN CONNECTION WITH ANY HANDLING OR USE OF THE EVM THAT IS NOT IN ACCORDANCE WITH THESE TERMS. THIS OBLIGATION SHALL APPLY WHETHER CLAIMS ARISE UNDER STATUTE, REGULATION, OR THE LAW OF TORT, CONTRACT OR ANY OTHER LEGAL THEORY, AND EVEN IF THE EVM FAILS TO PERFORM AS DESCRIBED OR EXPECTED.

8. *Limitations on Damages and Liability:*

8.1 *General Limitations.* IN NO EVENT SHALL TI BE LIABLE FOR ANY SPECIAL, COLLATERAL, INDIRECT, PUNITIVE, INCIDENTAL, CONSEQUENTIAL, OR EXEMPLARY DAMAGES IN CONNECTION WITH OR ARISING OUT OF THESE TERMS OR THE USE OF THE EVMS , REGARDLESS OF WHETHER TI HAS BEEN ADVISED OF THE POSSIBILITY OF SUCH DAMAGES. EXCLUDED DAMAGES INCLUDE, BUT ARE NOT LIMITED TO, COST OF REMOVAL OR REINSTALLATION, ANCILLARY COSTS TO THE PROCUREMENT OF SUBSTITUTE GOODS OR SERVICES, RETESTING, OUTSIDE COMPUTER TIME, LABOR COSTS, LOSS OF GOODWILL, LOSS OF PROFITS, LOSS OF SAVINGS, LOSS OF USE, LOSS OF DATA, OR BUSINESS INTERRUPTION. NO CLAIM, SUIT OR ACTION SHALL BE BROUGHT AGAINST TI MORE THAN TWELVE (12) MONTHS AFTER THE EVENT THAT GAVE RISE TO THE CAUSE OF ACTION HAS OCCURRED.

8.2 *Specific Limitations.* IN NO EVENT SHALL TI'S AGGREGATE LIABILITY FROM ANY USE OF AN EVM PROVIDED HEREUNDER, INCLUDING FROM ANY WARRANTY, INDEMNITY OR OTHER OBLIGATION ARISING OUT OF OR IN CONNECTION WITH THESE TERMS, , EXCEED THE TOTAL AMOUNT PAID TO TI BY USER FOR THE PARTICULAR EVM(S) AT ISSUE DURING THE PRIOR TWELVE (12) MONTHS WITH RESPECT TO WHICH LOSSES OR DAMAGES ARE CLAIMED. THE EXISTENCE OF MORE THAN ONE CLAIM SHALL NOT ENLARGE OR EXTEND THIS LIMIT.

9. *Return Policy.* Except as otherwise provided, TI does not offer any refunds, returns, or exchanges. Furthermore, no return of EVM(s) will be accepted if the package has been opened and no return of the EVM(s) will be accepted if they are damaged or otherwise not in a resalable condition. If User feels it has been incorrectly charged for the EVM(s) it ordered or that delivery violates the applicable order, User should contact TI. All refunds will be made in full within thirty (30) working days from the return of the components(s), excluding any postage or packaging costs.

10. *Governing Law:* These terms and conditions shall be governed by and interpreted in accordance with the laws of the State of Texas, without reference to conflict-of-laws principles. User agrees that non-exclusive jurisdiction for any dispute arising out of or relating to these terms and conditions lies within courts located in the State of Texas and consents to venue in Dallas County, Texas. Notwithstanding the foregoing, any judgment may be enforced in any United States or foreign court, and TI may seek injunctive relief in any United States or foreign court.

Mailing Address: Texas Instruments, Post Office Box 655303, Dallas, Texas 75265
Copyright © 2023, Texas Instruments Incorporated

IMPORTANT NOTICE AND DISCLAIMER

TI PROVIDES TECHNICAL AND RELIABILITY DATA (INCLUDING DATASHEETS), DESIGN RESOURCES (INCLUDING REFERENCE DESIGNS), APPLICATION OR OTHER DESIGN ADVICE, WEB TOOLS, SAFETY INFORMATION, AND OTHER RESOURCES "AS IS" AND WITH ALL FAULTS, AND DISCLAIMS ALL WARRANTIES, EXPRESS AND IMPLIED, INCLUDING WITHOUT LIMITATION ANY IMPLIED WARRANTIES OF MERCHANTABILITY, FITNESS FOR A PARTICULAR PURPOSE OR NON-INFRINGEMENT OF THIRD PARTY INTELLECTUAL PROPERTY RIGHTS.

These resources are intended for skilled developers designing with TI products. You are solely responsible for (1) selecting the appropriate TI products for your application, (2) designing, validating and testing your application, and (3) ensuring your application meets applicable standards, and any other safety, security, regulatory or other requirements.

These resources are subject to change without notice. TI grants you permission to use these resources only for development of an application that uses the TI products described in the resource. Other reproduction and display of these resources is prohibited. No license is granted to any other TI intellectual property right or to any third party intellectual property right. TI disclaims responsibility for, and you fully indemnify TI and its representatives against any claims, damages, costs, losses, and liabilities arising out of your use of these resources.

TI's products are provided subject to [TI's Terms of Sale](#), [TI's General Quality Guidelines](#), or other applicable terms available either on ti.com or provided in conjunction with such TI products. TI's provision of these resources does not expand or otherwise alter TI's applicable warranties or warranty disclaimers for TI products. Unless TI explicitly designates a product as custom or customer-specified, TI products are standard, catalog, general purpose devices.

TI objects to and rejects any additional or different terms you may propose.

Copyright © 2025, Texas Instruments Incorporated

Last updated 10/2025