

Application Note

Idle Channel Tones in Audio Converters



Lakshmi Narasimhan Badrinarayanan, Ramsey Foote

ABSTRACT

This application note describes the *idle tones* seen as the output spectrum of an audio ADC. These idle tones are an inherent behavior seen in delta-sigma ADCs and can sometimes be seen when the inputs are idle (or silent). The document goes over the reasons for this behavior and how to address this with examples using two different audio ADCs.

Table of Contents

1 Introduction	2
2 Detailed Description	2
2.1 Why Idle Tones?.....	2
2.2 How To Improve Idle Channel Spectrum in Audio Band.....	5
3 Summary	10
4 References	10

Trademarks

All trademarks are the property of their respective owners.

1 Introduction

The noise when the inputs of an audio Analog-to-Digital Converter (ADC) are idle is considered an important performance metric in high-end audio applications. In addition to overall signal-to-noise and dynamic range, the spectral behavior under such conditions also needs to be accounted for. Spurious tones above the noise floor of the idle channel spectrum can lead to undesirable artefacts, especially when the output is digitally amplified before further processing or before being played back through a speaker amplifier.

This app note explains why such idle tones can exist, and design methods to address the same.

2 Detailed Description

2.1 Why Idle Tones?

Figure 2-1 presents simple first-order Δ - Σ modulator with a one-bit output. The output of the integrator is digitized through a comparator (or a one-bit ADC). This output is fed back to the input signal through a one-bit DAC. This error signal is the input to the integrator.

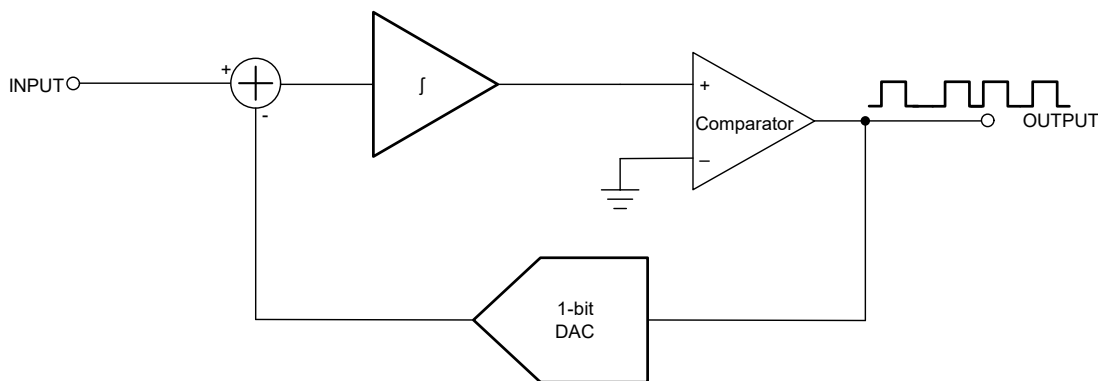

Figure 2-1. Delta-Sigma Modulator

This conversion is done at a rate much higher than the overall sampling rate of the ADC itself. This helps with:

1. Relaxed anti-aliasing filter bandwidth requirements, since the filter's bandwidth can be higher than the Nyquist bandwidth of the ADC.
2. Lower noise due to averaging/decimation of the comparator output down to the ADC's sampling rate.

At near-idle inputs (0V), the output of the comparator stage has a repeating pattern of 0101..., which translates to a spike at $\frac{F_{\text{mod}}}{2}$, F_{mod} being the sampling frequency of the modulator. With non-idealities like

1. Offset in the input path due to mismatches
2. F_{mod} causing modulation of the voltage reference

The spike frequencies change to $\frac{F_{\text{mod}} \pm \Delta f}{2}$, the Δf is the frequency change brought about by these non-idealities. These spikes, when decimated to an output sampling rate of F_s , can result in the "idle tones" being observed in the audible band of the ADC.

While the integrated noise can still be low and within spec, having tones above the actual noise floor is still an undesirable artifact in applications where the output is amplified before post-processing or passed to a speaker amplifier. While modern day audio ADCs are designed with multi-bit Δ - Σ modulators to obtain improved noise performance, repeating patterns with idle inputs still result in tones in the audio spectrum.

However, these repeating patterns are not there when the input is a moving signal. Figure 2-2 shows the FFT spectrum on the TLV320ADC6120 ADC (a) when the inputs are idle, and (b) with a -60dBFS, 1kHz sinusoidal signal. Figure 2-3 shows the FFT spectrums under the same input conditions on the PCM4222 ADC.

As is clearly visible in both Figure 2-2 and Figure 2-3, these tones disappear with input signals moving at amplitudes as low as -60dBFS.

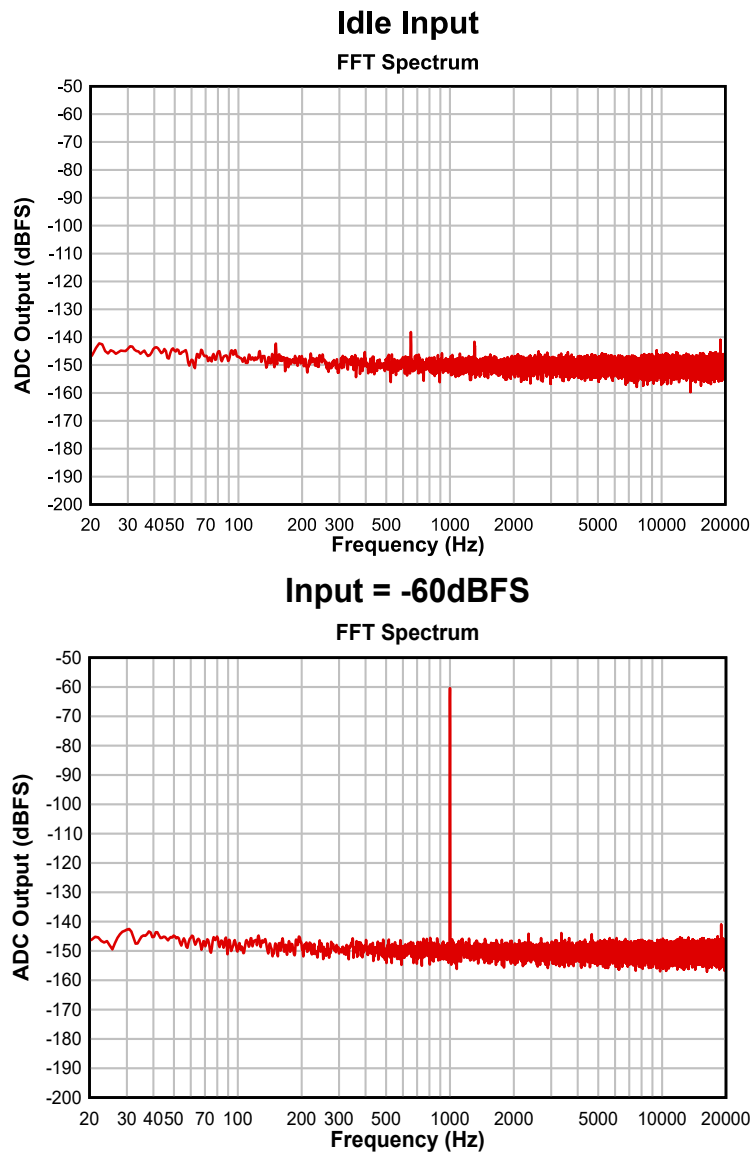

Figure 2-2. FFT Spectrum for TLV320ADC6120

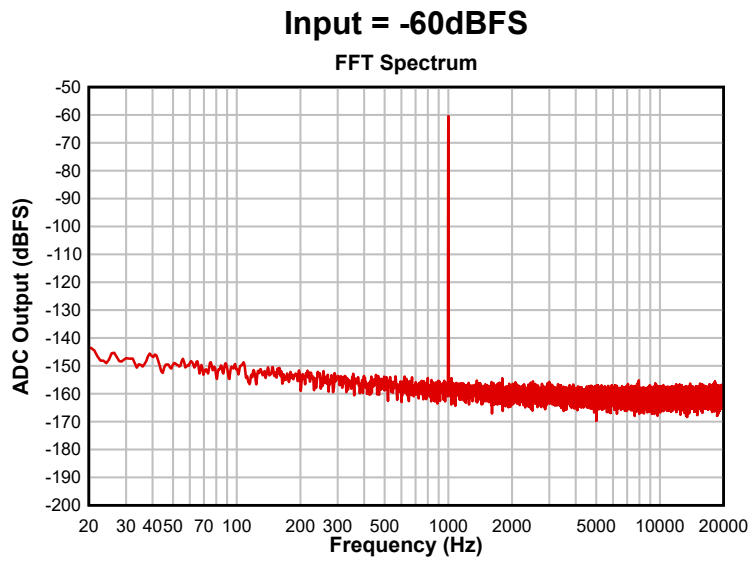
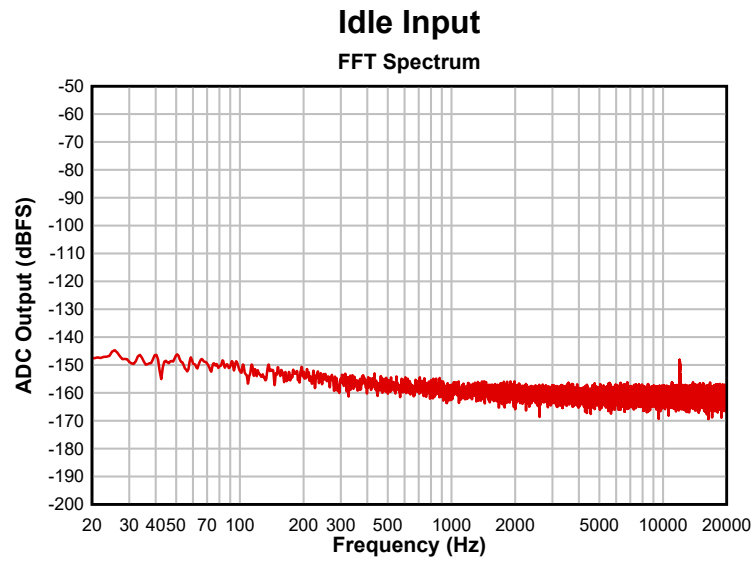

Figure 2-3. FFT Spectrum of PCM4222

2.2 How To Improve Idle Channel Spectrum in Audio Band

As mentioned in [Section 2.1](#), one of the components influencing the frequency of the repeating pattern is input DC offset voltage. Therefore, when the internal device offset results in idle tones in the audio band of interest (20Hz – 20kHz), the user can add an external compensatory offset to move these tones to frequencies outside the band of interest for the end application. [Section 2.2.1](#) describes how this is done with the TLV320ADC6120 ADC.

Another solution specifically for the PCM4220 and PCM4222 is to increase the VCC1 and VCC2 supplies above the typical 4V. operating voltage. [Section 2.2.2](#) shows the effect of this solution on the idle tones, and impact on other device performance parameters. [Section 2.2.2](#) also shows the effect of including a DC offset on the inputs of the PCM4222

The recently released ADCs like the TA5xxx incorporate techniques like improved element matching and internal offset addition, resulting in improved spectral behavior in the audio band.

2.2.1 Example 1 – TLV320ADC6120

[Figure 2-4](#) shows a test circuit with the TLV320ADC6120 operating with DC-coupled inputs. To test the spectral performance with idle inputs, the AC signal is set to 0Vrms, on a DC bias voltage of 1.486V on the INxP and INxM pins. A differential offset voltage of V_{OS} is then applied on the input differential pair.

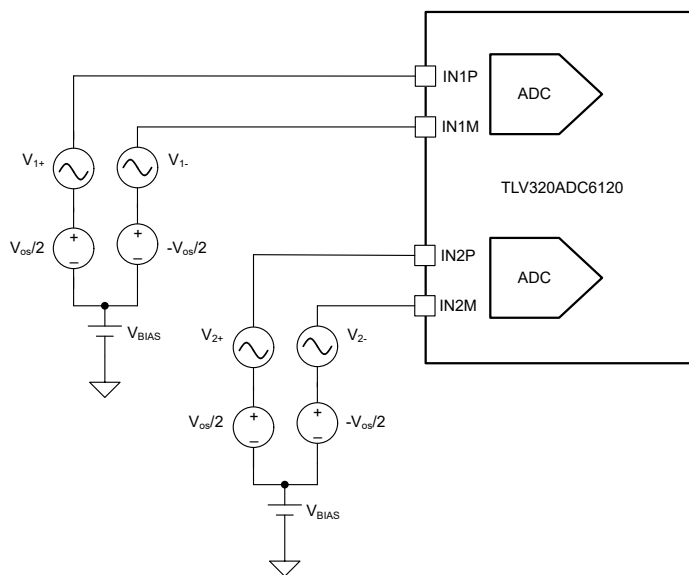

Figure 2-4. TLV320ADC6120 with DC-coupled Inputs

[Figure 2-5](#) shows the FFTs of the ADC output when the offset is set to 0mV, 5mV, 10mV, 15mV and 20mV.

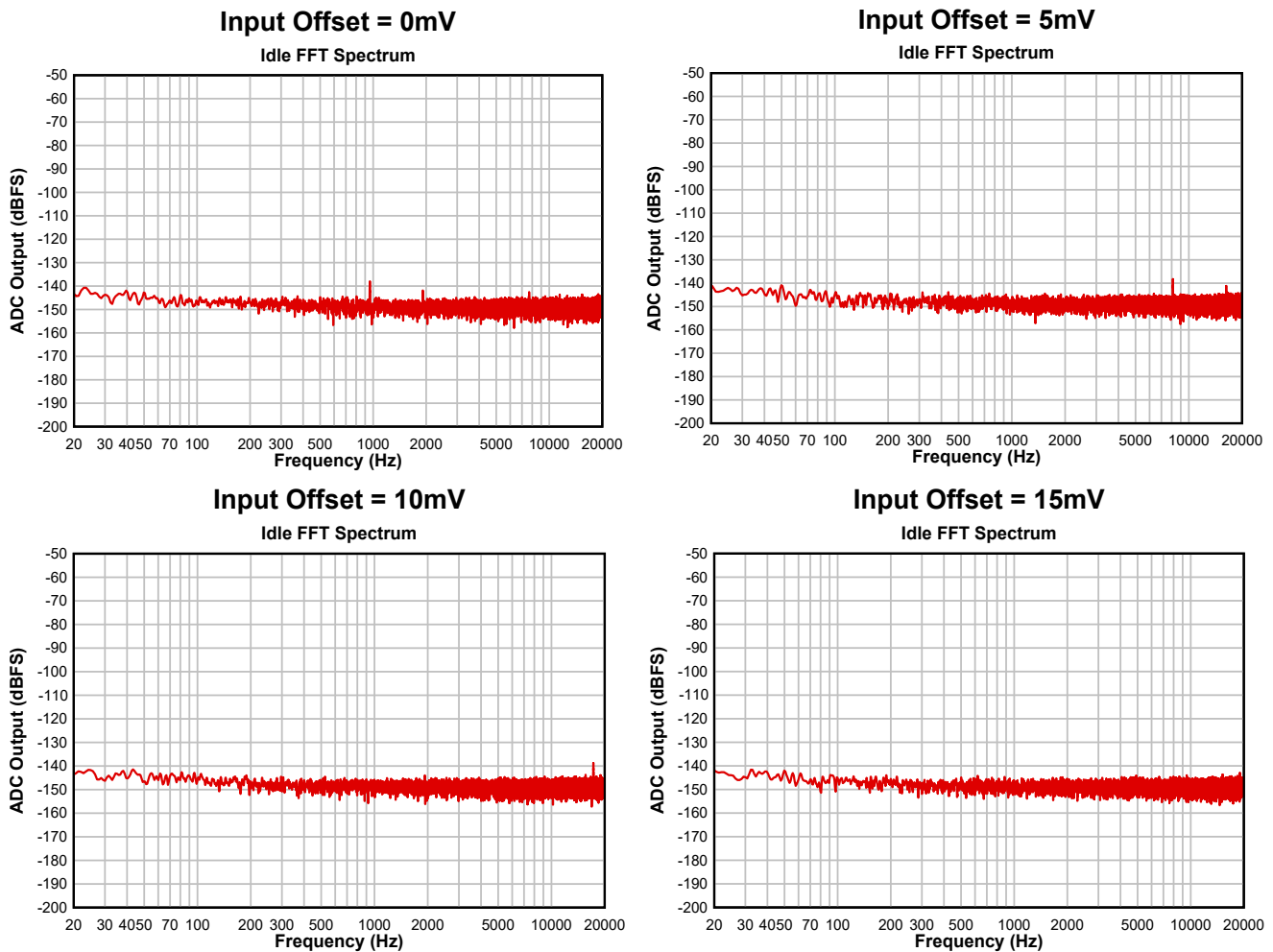

Figure 2-5. Idle FFT Spectrum Across Offset

As seen from the graphs, the tones in the idle channel spectrum are shifted to higher frequencies when an offset voltage is applied, at 15mV moving out of the 20Hz-20kHz audio band.

One thing to note is that this solution requires the inputs to be DC-coupled, since an AC-coupling capacitor would block out any DC offset added along with the signal. Per Table 7-1 in the [Input Common-Mode Tolerance & High CMRR Modes TLV320ADCx120 & PCMx120-Q1 Devices \(Rev. A\)](#) application note, the SNR for DC-coupled input at 10kΩ is ~2dB lesser than for AC-coupled input with DRE disabled.

This solution is applicable to all TLV320ADCx120, TLV320ADCx140, PCMx140-Q1 and PCMx120-Q1 devices where the inputs can be configured to be DC-coupled.

One common way to introduce a DC bias voltage to the inputs of the ADC is to use a voltage divider that has resistors R and R, on a voltage rail "V_{CC}". The divider's output is then used to bias the INxP and INxM pins to a DC voltage $\frac{V_{CC}}{2}$ V. [Figure 2-6 \(a\)](#) shows the resistive divider, where both INxP and INxM are biased from the mid-point of the divider.

To introduce an offset at between the pins, the resistor "R_{OS}" is introduced into the divider. The INxP and INxM pins are then biased from either side of the ROS resistor, as shown in [Figure 2-6 \(b\)](#). The voltage across the resistor, (the offset being introduced), is calculated as:

$$V_{OS} = \frac{V_{CC} * R_{OS}}{2 * R + R_{OS}} V \quad (1)$$

$$\therefore R_{OS} = \frac{2 \cdot V_{OS} \cdot R}{V_{CC} - V_{OS}} \Omega \quad (2)$$

For example, if a voltage divider is made using 2.2kΩ resistors on a 3.3V supply rail, then a R_{OS} of ~20.1Ω can be used to introduce an offset of 15mV between the INxP and INxM pins.

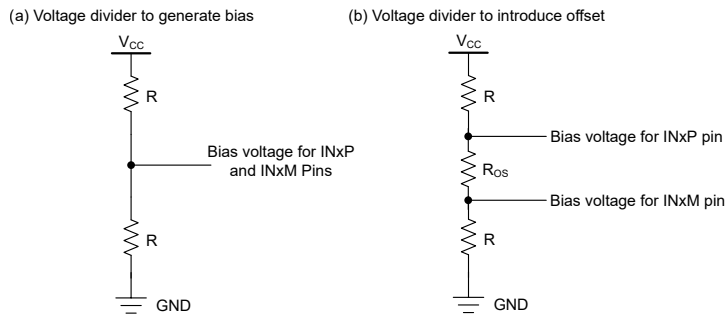

Figure 2-6. Voltage Divider Scheme to Introduce DC Offset

2.2.2 Example 2 – PCM4222

Figure 2-7 shows the typical connections to operate the PCM4222 in PCM or DSD mode.

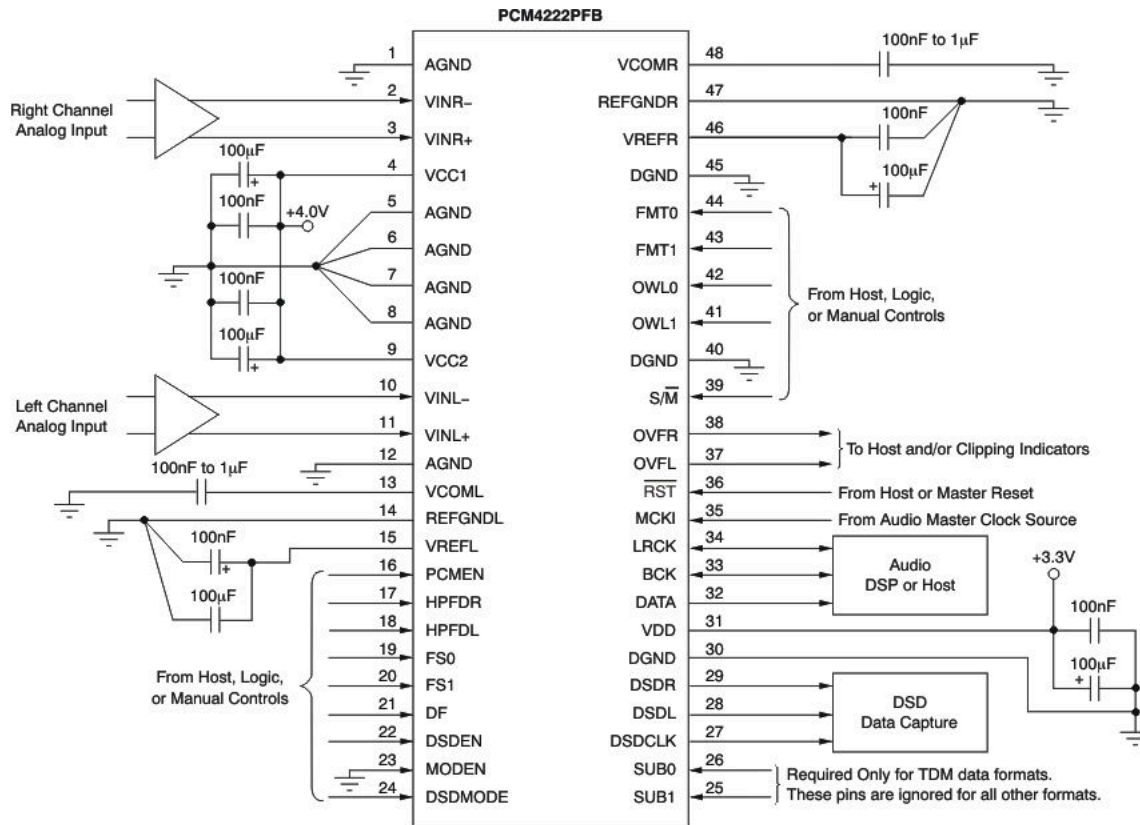

Figure 2-7. Typical Connections for PCM and DSD Output Modes

Figure 2-8 shows the FFT spectrum for idle input with 0mV and 5mV offset voltages.

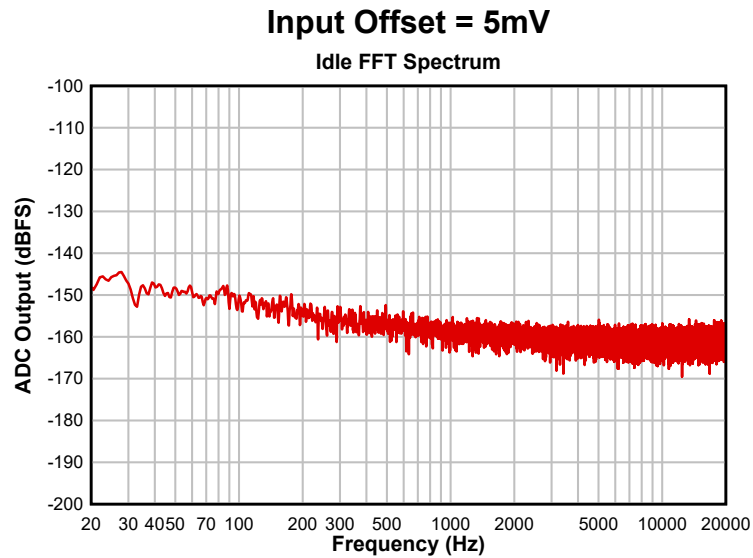
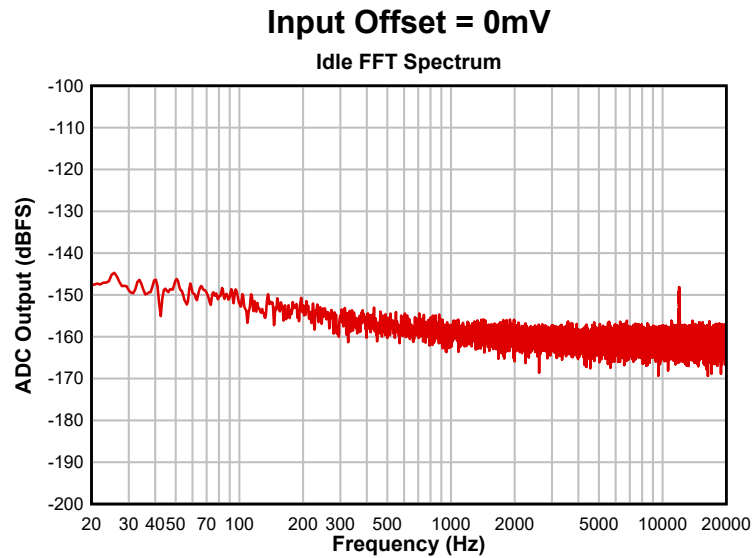

Figure 2-8. FFT Spectrum for 0mV and 5mV Offset

Another solution to address the spurious idle channel tones on PCM4222 is to change the operating VCC1 and VCC2 supply voltages' value from 4V to 4.35V. The FFT with improved spectral performance is shown in [Figure 2-9](#).

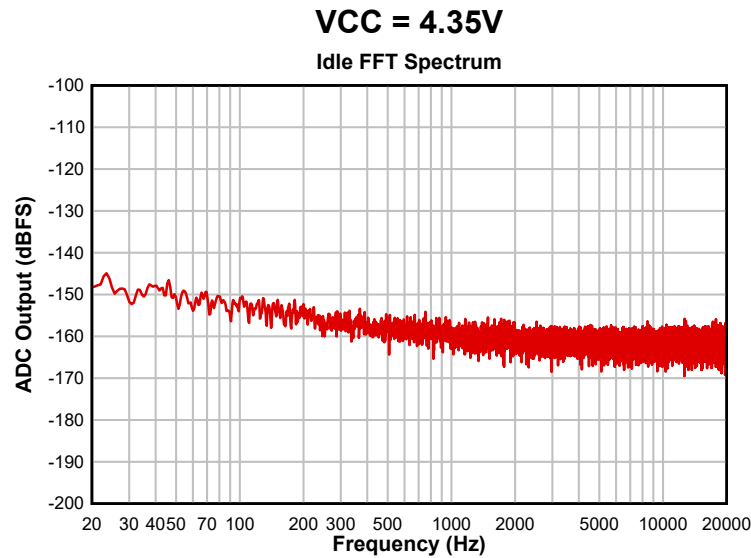
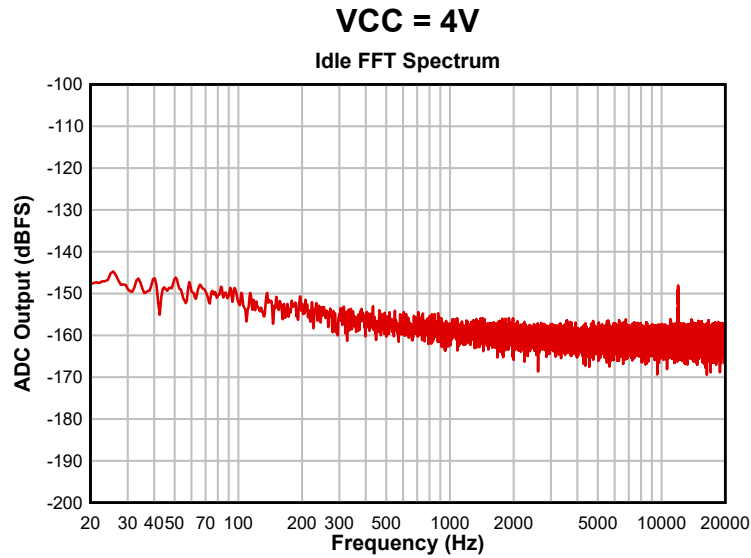

Figure 2-9. FFT Spectrum for 4V and 4.35V VCC

The user should note, however, that operating the device at this supply value impacts ADC's performance. For the device under test in this example, the THD+N changed from **-108dB** (at 4V) to **-104dB** (at 4.35V).

3 Summary

Using the practices described in this application note with examples, users can incorporate designs using TI's family of audio ADCs. These designs would then meet the of spurious free spectral requirement needed in certain audio applications, with some impact on overall performance.

4 References

1. Texas Instruments, [TLV320ADC6120 2-Channel, 768-kHz, Burr-Brown™ Audio ADC](#), datasheet.
2. Texas Instruments, [High-Performance, 2-Channel, 24-Bit, 216kHz Sampling Multi-Bit Delta-Sigma A/D](#), datasheet.
3. Texas Instruments, [\[FAQ\] PCM4220: PCM4220 Idle Tone - Audio forum - Audio - TI E2E support forums](#), FAQ

IMPORTANT NOTICE AND DISCLAIMER

TI PROVIDES TECHNICAL AND RELIABILITY DATA (INCLUDING DATASHEETS), DESIGN RESOURCES (INCLUDING REFERENCE DESIGNS), APPLICATION OR OTHER DESIGN ADVICE, WEB TOOLS, SAFETY INFORMATION, AND OTHER RESOURCES "AS IS" AND WITH ALL FAULTS, AND DISCLAIMS ALL WARRANTIES, EXPRESS AND IMPLIED, INCLUDING WITHOUT LIMITATION ANY IMPLIED WARRANTIES OF MERCHANTABILITY, FITNESS FOR A PARTICULAR PURPOSE OR NON-INFRINGEMENT OF THIRD PARTY INTELLECTUAL PROPERTY RIGHTS.

These resources are intended for skilled developers designing with TI products. You are solely responsible for (1) selecting the appropriate TI products for your application, (2) designing, validating and testing your application, and (3) ensuring your application meets applicable standards, and any other safety, security, regulatory or other requirements.

These resources are subject to change without notice. TI grants you permission to use these resources only for development of an application that uses the TI products described in the resource. Other reproduction and display of these resources is prohibited. No license is granted to any other TI intellectual property right or to any third party intellectual property right. TI disclaims responsibility for, and you fully indemnify TI and its representatives against any claims, damages, costs, losses, and liabilities arising out of your use of these resources.

TI's products are provided subject to [TI's Terms of Sale](#), [TI's General Quality Guidelines](#), or other applicable terms available either on [ti.com](#) or provided in conjunction with such TI products. TI's provision of these resources does not expand or otherwise alter TI's applicable warranties or warranty disclaimers for TI products. Unless TI explicitly designates a product as custom or customer-specified, TI products are standard, catalog, general purpose devices.

TI objects to and rejects any additional or different terms you may propose.

Copyright © 2026, Texas Instruments Incorporated

Last updated 10/2025