

CC13xx Combined wM-Bus C-Mode and T-Mode

ABSTRACT

This application report describes a combined wM-Bus C-Mode and T-Mode patch for the CC13xx SimpleLink™ Sub-1 GHz ultra-low power wireless microcontroller.

Recommended register settings discussed in this application report can be downloaded from <http://www.ti.com/lit/zip/SWRA522>.

Contents

1	Introduction	2
2	Combined wM-Bus C-Mode and T-Mode Patch	2
	2.1 RX.....	2
	2.2 TX.....	3
	2.3 Recommended Operating Limits	3
	2.4 Configuration and Status Registers	4
3	Building a Software Example.....	5
4	C-Mode Measurement Summary	7
	4.1 Sensitivity vs Frequency Deviation	7
	4.2 C-Mode Blocking.....	8
	4.3 PER versus Input Power Level	8
	4.4 PER versus Frequency Offset	10
5	T-Mode Measurement Summary	11
	5.1 Sensitivity versus Frequency Deviation	11
	5.2 Sensitivity versus Data Rate Offset	11
	5.3 T-Mode Blocking	11
	5.4 PER versus Input Power Level	11
	5.5 PER versus Frequency Offset	14
	5.6 PER versus Symbol Rate Offset	16
6	References	17

Trademarks

SimpleLink, SmartRF are trademarks of Texas Instruments.
 All other trademarks are the property of their respective owners.

1 Introduction

This application note provides a brief description of the patch, relevant status and configuration registers, and required overrides. The performance figures for the CC1310 device when using the patch are included in [Section 4](#) and [Section 5](#).

All measurements were performed on the CC13xxEM-7793_4L reference design [1].

Measurements show that the CC13xx device meets EN13757-4:2012 [2] specifications with margin.

2 Combined wM-Bus C-Mode and T-Mode Patch

The wM-Bus PHY T-Mode and C-Mode are not available in ROM code, and a wM-Bus patch is needed to support these physical layers. The wM-Bus stack must use Proprietary API commands together with wM-Bus related overrides. The patch is part of the SimpleLink™ CC13x0 Software Development Kit [5] and recommended settings and overrides are covered in [Section 2.3](#).

2.1 RX

The wM-Bus T-Mode and C-Mode patch can receive both T-Mode and C-Mode packets.

For C-Mode, the first 16 chips of the sync word (=0x543D) are equal to the preamble and sync word of T-Mode. The next 8 chips in C-Mode are the bit pattern *01010100*. This pattern will never occur in a 3-out-of-6 encoded T-Mode frame.

When the CC1310 wakes up into RX, it will start to search for a valid sync word (=0x543D). Because it is not known whether it is a T-Mode or a C-Mode packet, 8 chips following the sync word will also be checked.

- If 01010100 is *not* detected, a T-Mode packet will be received and the patch will handle the 3-out-of-6 decoding. No CRC check is done by the patch. Automatic CC1310 CRC check must be disabled. CRC check must be handled by the application software.
- If 01010100 is detected, a C-Mode packet will be received. The patch automatically removes the 01010100 signaling byte. No CRC check is done by the patch. Automatic CC1310 CRC check must be disabled. CRC check must be handled by the application software.

After setting the CC13xx device into RX, a search for valid sync word will only take place if one of the following conditions is fulfilled:

- (16 bit preamble detection with 0 bit errors) && CS
- (12 bit preamble detection with up to 2 bit errors) && CS over 20 symbols.

The carrier sense (CS) threshold is set to -107 dBm. In an environment with a noise floor above -107 dBm, it is advantageous to increase the CS threshold to reduce the likelihood of processing a false packet. If the CC13xx device is preoccupied processing a false packet, there is a finite possibility that a true packet will be missed.

The CS threshold is set by bits [7–0] in register 0x400 4609 (see [Table 1](#)).

Table 1. Carrier Sense Threshold

Register	Bit	Field Name	Description
0x4004 6090	7–0	CS_THR	Carrier Sense Threshold CS_THR_dBm = CS_THR–256 [dBm]

As an example, the following register write sets the carrier sense threshold to -107 dBm:

```
HW_REG_OVERRIDE (0x6090, 0x0A95)
```

Increasing the carrier threshold to -104 dBm (for example) gives HW_REG_OVERRIDE (0x6090, 0x0A98).

2.2 TX

The wM-Bus T-Mode and C-Mode patch can transmit both T-Mode and C-Mode packets.

- In T-Mode, the patch does the 3-out-of-6 encoding of data.
- In C-Mode, the patch automatically inserts 01010100 signaling byte after the preamble and sync word. The patch does not do any encoding of data in C-Mode.
- Automatic CC1310 CRC calculation must be disabled. CRC calculation must be handled by the application software.

wM-Bus must be run with wM-Bus T-Mode and C-Mode MCE patch and may run RFE from ROM.

2.3 Recommended Operating Limits

The patch is only designed for wM-Bus T-Mode and C-Mode. This means that the patch has many values that are hard coded (for example, data rate in RX and packet format). To make the patch work properly, the user must set the following:

- Set the data rate to 100 kbps in RX.
- Set the number of preambles to ≥ 4 bytes.
- Set the sync word to 0x0000 543D.
- Set the number of sync word bits to 16.
- Enable the MSB first.
- Set the RF frequency to 868.95 MHz.
- Do not change the correlator setting through the Prop API. Use override (uint32_t)0x0004 8103 to let the patch control the correlator setting.
- The maximum sync search time is 6 minutes. If sync is not found within this time limit, RX should be restarted.

2.3.1 API Configuration

Table 2 lists the required changes to the recommended 50-kbps, 2-GFSK radio operation commands from SmartRF™ Studio [4] to be compliant with recommended operation limits listed in Section 2.3. [3] contains a complete list of the four radio operation commands listed in Table 2, together with necessary include paths and overrides.

Table 2. API Settings Required for the Patch

Radio Operation Command	Field Name	Value
CMD_PROP_RADIO_DIV_SETUP	modulation.modType	0
	modulation.deviation	0xC8 (T-Mode), 0xB4 (C-Mode)
	symbolRate.preScale	0xC
	symbolRate.rateWord	0xCCCC
	rxBw	0x27
	preamConf.nPreamBytes	0x4
	preamConf.preamMode	0
	formatConf.nSwBits	0x10
	formatConf.bMsbFirst	0x1
	centerFreq	0x0364
	intFreq	0x8000
CMD_FS	loDivider	0x05
	frequency	0x0364
CMD_PROP_TX	fractFreq	0xF333
	syncWord	0x0000 543D
CMD_PROP_RX	syncWord	0x0000 543D

2.3.2 Register Overrides

Table 3 lists the overrides needed *in addition* to the recommended 50-kbps, 2-GFSK radio register settings from SmartRF Studio [4] to be compliant with recommended operation limits listed in Section 2.3. [3] contains a complete list of the necessary overrides together with radio operation commands and include paths.

Table 3. Additional Register Overrides Required for the Patch

Override	Comment
HW_REG_OVERRIDE(0x6064,0x1101)	AGC winsize 2 samples
HW_REG_OVERRIDE(0x6090,0xA095)	CS threshold to -107 dBm
(uint32_t)0x0004 8103	Let the patch control the correlator setting
HW_REG_OVERRIDE(0x51F8,0x0000)	Clear state in internal radio register due to frequency change
HW32_ARRAY_OVERRIDE(0x405C,1)	Set divider bias to disabled
(uint32_t)0x1800 0200	Divider 5
0xC004 0031	TX shape in T-Mode ⁽¹⁾
(uint32_t)&txShapeTMode[0]	
0xC004 0031	TX shape in C-Mode ⁽¹⁾
(uint32_t)&txShapeCMode[0]	

⁽¹⁾ Only one of the shapes must be selected. The shapes should be defined as follows:
 uint32_t txShapeTMode[] = {0x0000 0000, 0x0000 0000, 0x0000 0000, 0x4B11 0200, 0xF2F0 E1A6, 0xF2F2 F2F2};
 uint32_t rxShapeCMode[] = {0x0000 0000, 0x0000 0000, 0x0000 0000, 0x440F 0200, 0xD9D8 CA96, 0xD9D9 D9D9};

Three of the 50-kbps, 2-GFSK radio register settings from SmartRF Studio must be changed (see Table 4).

Table 4. Register Overrides to be Changed from 50-kbps, 2-GFSK Radio Register Settings

Override	Comment
MCE_RFE_OVERRIDE(1, 0, 0, 1, 0, 0)	Run the MCE and RFE patches
HW_REG_OVERRIDE(0x6088,0x082E)	PA ramping
HW_REG_OVERRIDE(0x608C,0x0407)	PA ramping and AGC settle wait = 16 samples

2.4 Configuration and Status Registers

Table 5 lists the configuration register available in the wM-Bus patch.

Table 5. Configuration Registers

Register	Bit	Field Name	Description	Default
0x4004 52B4	14	TxPacketType	0: Transmit T-Mode packet 1: Transmit C-Mode packet	0x00
	13	Invert Data	0: No invert T-Mode data 1: Invert T-Mode Data	0x00
	12	DisablePQT	0: Preamble qualifier enabled 1: Preamble qualifier disabled	0x00
	11-0	Not in use		0x00

This register can only be changed through static overrides of the following format:

HW_REG_OVERRIDE(0x52B4, 0xXXXX)

Table 6 lists the status registers available in the wM-Bus patch.

Table 6. Status Registers

Register	Bit	Field Name	Description	Default
0x4004 5178	15–0	RxPacketType	0: Received T-Mode packet 1: Received C-Mode packet	0x00
0x4004 5180	15–0	SyncTimCnt	Sync search timeout counter	0x00
0x4004 5184	15–0	SymRateEst	Symbol rate estimation	0x00

The registers can be read using the `CMD_READ_RFREG` API command.

2.4.1 T-Mode Packets

The patch is default transmitting T-Mode packets. T-Mode packets are transmitted as long as Bit 14 of the hardware register 0x4004 52B4 is zero.

The patch automatically does the 3-out-of-6 coding. The 3-out-of-6 coding is according to EN13757-4 [4].

The application software needs to read the *RxPacketType* (see Table 6) in order to know which packet type is received.

2.4.2 C-Mode Packets

The patch is transmitting C-Mode packets when the *TxPacketType* (see Table 5) is set to 1. The C-Mode packet has no coding.

The patch automatically inserts and removes the C-Mode signaling byte 01010100 following the preamble and sync word.

The application software needs to read the *RxPacketType* (see Table 6) in order to know which packet type is received.

3 Building a Software Example

To test the RF performance of the patch, the user can refer to the `rfPacketRX` and `rfPacketTX` example available when downloading the SimpleLink™ CC13x0 Software Development Kit [5]. See the Proprietary RF Quick Start Guide for more information. A local link to this guide can be found in the `documentation_overview_simplelink_cc13x0_sdk.html` found here:

`C:\ti\simplelink_cc13x0_sdk_x_xx_xx_xx\docs` (assuming that installation has been to default location)

The `smartrf_settings.c` file must be modified with the settings from [3].

NOTE: When using the `rfPacketRX/TX` examples, the correct packet format will not be transmitted (with respect to CRC and length information).

The example and settings use variable packet-length mode and the default CRC from the CC13xx device, so the packets sent will appear as shown in Figure 1.

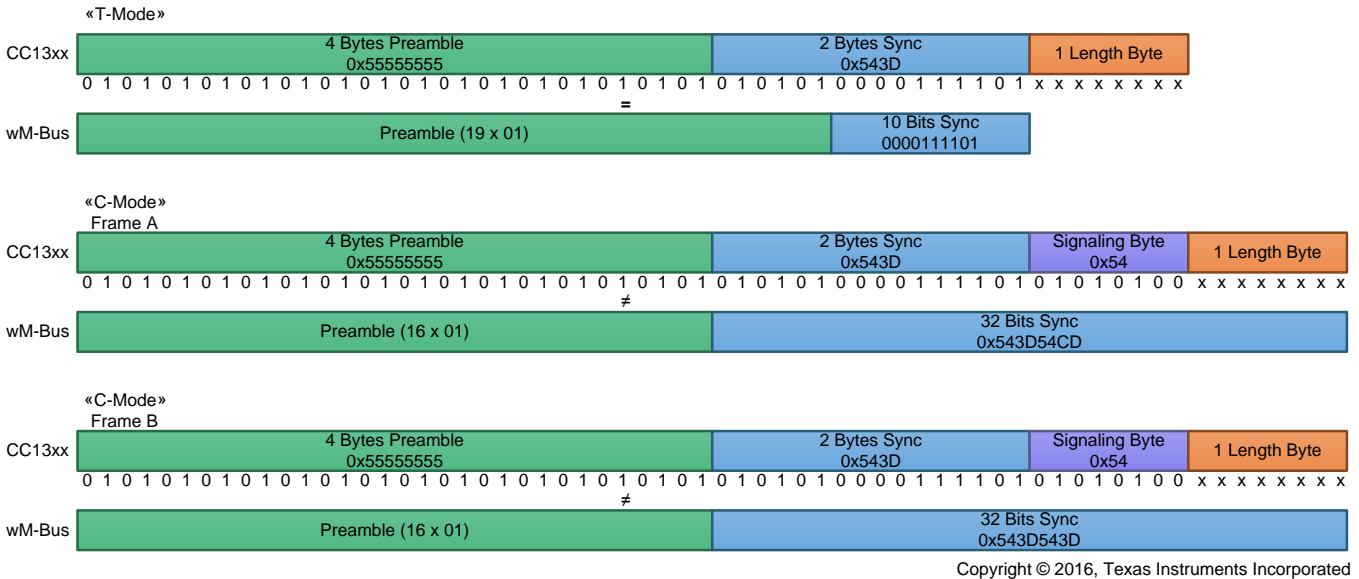

Figure 1. Packets Sent When Using rfPacketTx (Not Showing Payload and CRC)

The receiver will be set up to look for a 2-byte sync word (0x543D) and then to interpret the next byte received as the length byte.

NOTE: Remember that the signaling byte is removed by the patch.

Figure 1 shows that for C-Mode packets, the CC13xx device will not send the last byte of the sync word (the byte containing info regarding frame format [A or B]).

To make an example that uses the correct packet format, the following actions must be taken:

TX:

In TX mode, the user should use fixed packet length and disable CRC. For T-Mode, the length info should be the first byte, while for C-Mode, the byte containing the frame format information should be the first byte and the length byte should be the second byte (see Figure 2).

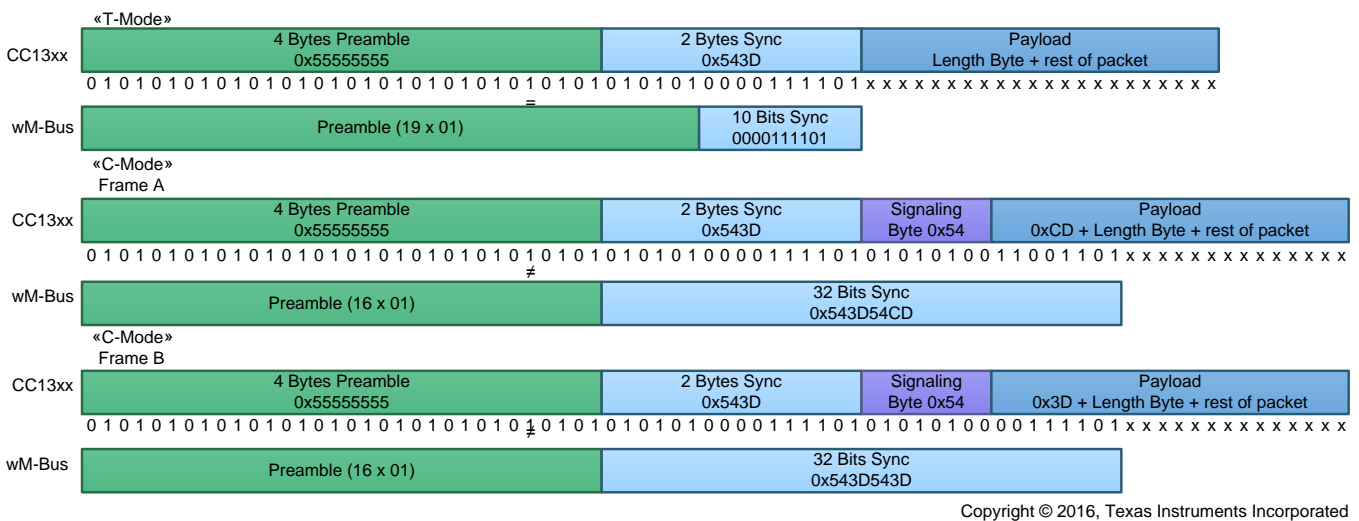

Figure 2. TX When Using Fixed Packet Length

RX:

Because the patch is supporting both C-Mode and T-Mode and the receiver is unaware which packets will be received, the receiver is only searching for a 16-bit sync word (0x543D) because this is common for both modes. If a T-Mode packet is received, the length information will be the first byte the RF Core writes to the data entry used to store the received packet. If a C-Mode packet is received, the byte containing the frame format information is the first byte put in the data entry and the length byte is the second byte (the signaling byte is removed by the patch). This means that it is not possible to configure the radio in variable packet length mode because the length information is located at different byte indexes with respect to the 16-bit sync word. Fixed packet length cannot be used either because the length is not known by the receiver.

The solution is to configure the receiver for unlimited length and then use the `CMD_PROP_SET_LEN` to set the proper length after the length information has been received.

NOTE: When using unlimited length mode, partial read entries must be used.

Pseudo Code:

Use the following steps for pseudo code:

1. Enter RX and wait for the `Rx_N_Data_Written` interrupt.
2. When interrupt is received, read `RxPacketType` (see [Table 6](#)) to determine if the packet is T-Mode or C-Mode.
3. If T-Mode, interpret the first byte in the entry as the length byte.
4. If C-Mode, interpret the second byte as the length byte.
5. Use the length information to set the proper length using `CMD_PROP_SET_LEN`.

4 C-Mode Measurement Summary

All measurements performed with 4-byte preamble except PER versus Input Power Level (see [Section 4.3](#)).

4.1 Sensitivity vs Frequency Deviation

C-Mode allows the frequency deviation parameter to vary from ± 33.75 kHz to ± 56.25 kHz, where ± 45 kHz is the nominal value. [Table 7](#) lists the measurement results.

Table 7. C-Mode 1% BER Sensitivity (55% PER, 10-Byte Payload)

Frequency [MHz]	Typical Sensitivity [dBm]	Deviation [kHz]
868.95	-105.6	33.75
	-106.3	45 (nominal)
	-105.9	56.25

4.2 C-Mode Blocking

Table 8 lists the C-Mode blocking performance. Wanted signal is 3 dB above the minimum useable sensitivity level.

Table 8. C-Mode Blocking

Frequency Offset [MHz]	Blocking [dB]
±10	68 / 67
±5	61 / 54
±2	52 / 51
±1	51 / 42
±0.5	47 / 45

4.3 PER versus Input Power Level

The following lists PER versus Input Power Level parameters:

- 100 bps, ±45-kHz deviation (nominal)
- 100 bps, ±33.75-kHz deviation (minimum deviation)
- 100 bps, ±56.25-kHz deviation (maximum deviation)
- 200 packets were transmitted at each power level
- 55% PER (packet error rate) corresponds to 1% BER (bit error rate)

4.3.1 4-Byte Preamble

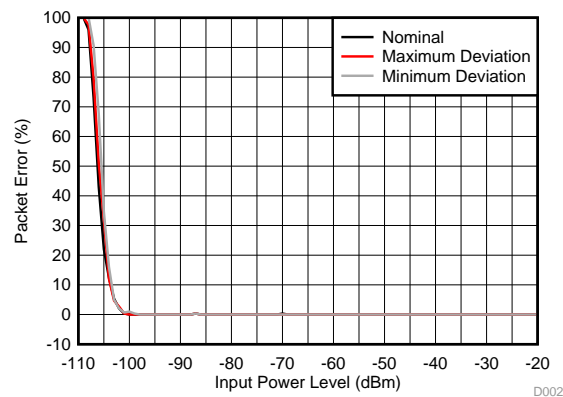

Figure 3. C-Mode PER vs Input Power Level, 4-Byte Preamble, 10-Byte Payload. Nominal, Minimum, and Maximum Deviation

4.3.2 5-Byte Preamble

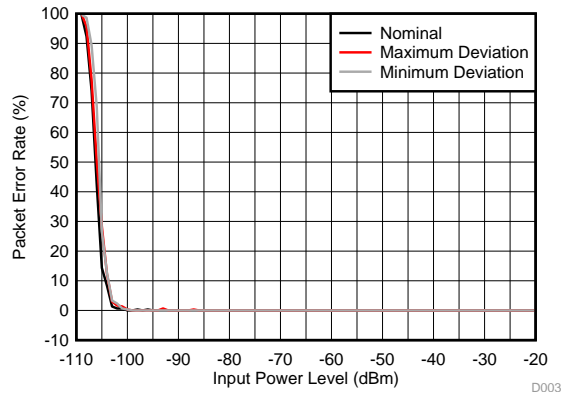

Figure 4. C-Mode PER vs Input Power Level, 5-Byte Preamble, 10-Byte Payload. Nominal, Minimum, and Maximum Deviation

4.3.3 6-Byte Preamble

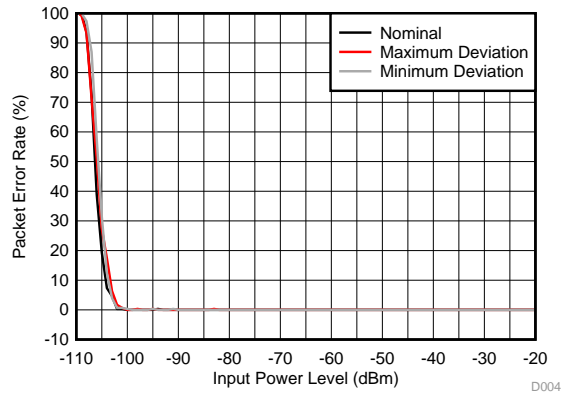

Figure 5. C-Mode PER vs Input Power Level, 6-Byte Preamble, 10-Byte Payload. Nominal, Minimum, and Maximum Deviation

4.3.4 10-Byte Preamble

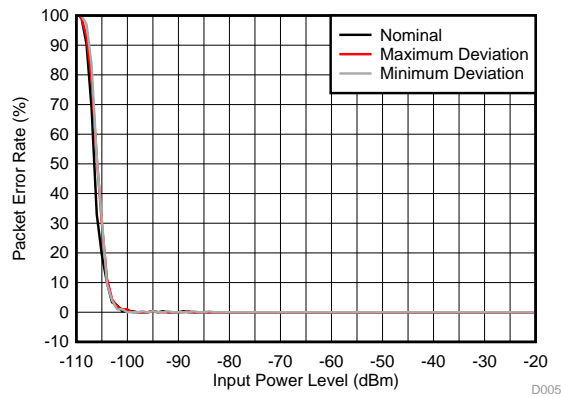

Figure 6. C-Mode PER vs Input Power Level, 10-Byte Preamble, 10-Byte Payload. Nominal, Minimum, and Maximum Deviation

4.4 PER versus Frequency Offset

The frequency offset can be up to ± 25 ppm in C-Mode. In [Figure 7](#) through [Figure 9](#), 55% PER corresponds to 1% BER.

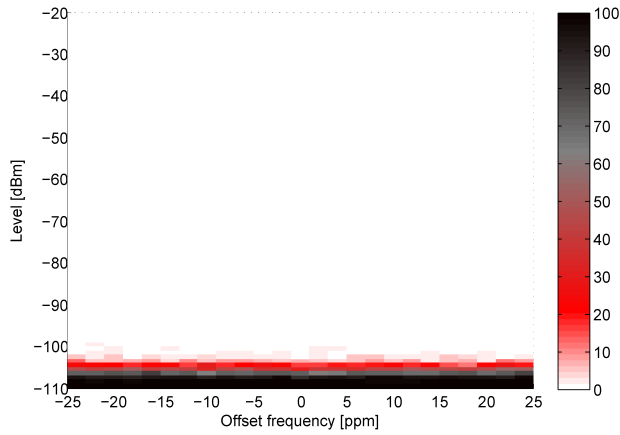

Figure 7. C-Mode 100 kbps, ± 45 kHz, 10-Byte Payload

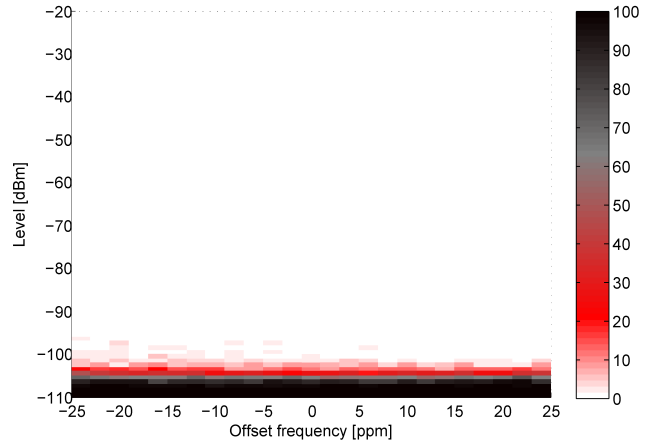

Figure 8. C-Mode 100 kbps, ± 33.75 kHz, 10-Byte Payload

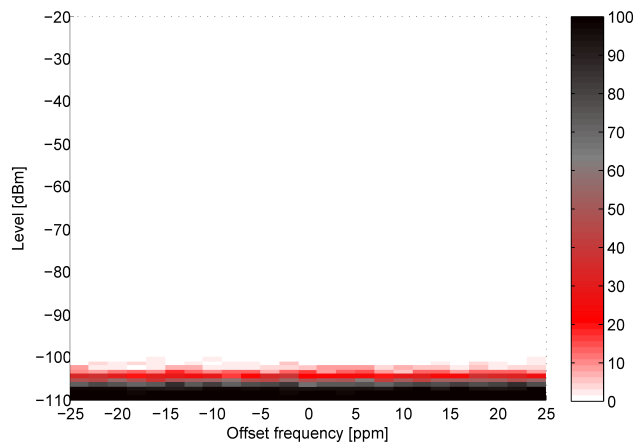

Figure 9. C-Mode 100 kbps, ± 56.25 kHz, 10-Byte Payload

5 T-Mode Measurement Summary

All measurements are performed with 4-byte preamble except PER versus input power level (see [Section 5.4](#)).

5.1 Sensitivity versus Frequency Deviation

T-Mode allows the frequency deviation parameter to vary from ± 40 kHz to ± 80 kHz, where ± 50 kHz is the nominal value. [Table 9](#) lists the measurement results.

Table 9. T-Mode Typical 1% BER Sensitivity (55% PER, 10-Byte Payload)

Frequency [MHz]	Typical Sensitivity [dBm]	Deviation [kHz]
868.95	-105.0	40
	-105.0	50 (nominal)
	-101.6	80

5.2 Sensitivity versus Data Rate Offset

The chip transmit rate for *meter to other* in T-Mode is between 90 kcps and 110 kcps, where 100 kcps is the nominal value. [Table 10](#) lists the measurement results.

Table 10. T-Mode Typical 1% BER Sensitivity (55% PER, 10-Byte Payload)

Frequency [MHz]	Typical Sensitivity [dBm]	Chip Rate [kcps]
868.95	-105.2	90
	-105.0	100 (nominal)
	-104.6	110

5.3 T-Mode Blocking

[Table 11](#) lists the T-Mode blocking performance. Wanted signal is 3 dB above the minimum useable sensitivity level.

Table 11. T-Mode Blocking

Frequency Offset [MHz]	Blocking [dB]
± 10	68 / 67
± 5	60 / 53
± 2	52 / 51
± 1	51 / 42
± 0.5	47 / 46

5.4 PER versus Input Power Level

- 100 kcps, ± 50 -kHz deviation (nominal)
- 100 kcps, ± 40 -kHz deviation (minimum deviation)
- 100 kcps, ± 80 -kHz deviation (maximum deviation)
- 90 kcps, ± 50 -kHz deviation (minimum data rate)
- 110 kcps, ± 50 -kHz deviation (maximum data rate)
- 200 packets were transmitted at each power level
- 55% PER (packet error rate) corresponds to 1% BER (bit error rate)

5.4.1 4-Byte Preamble

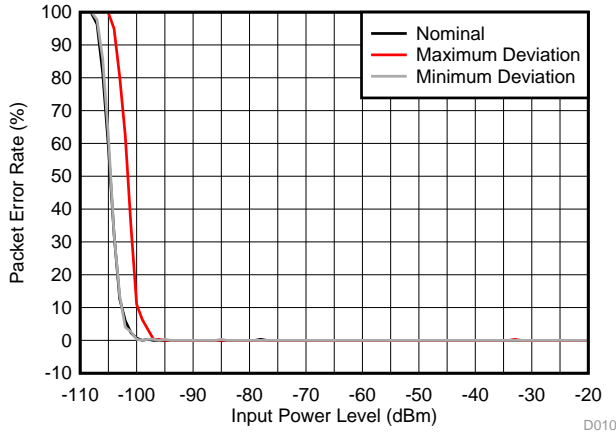

Figure 10. T-Mode PER vs Input Power Level, 4-Byte Preamble, 10-Byte Payload. Nominal, Minimum, and Maximum Deviation

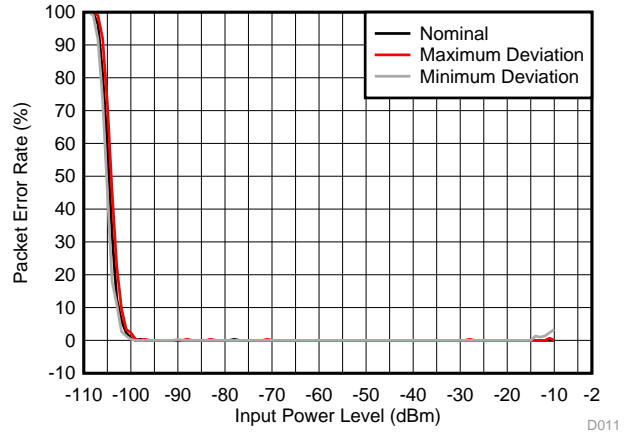

Figure 11. T-Mode PER vs Input Power Level, 4-Byte Preamble, 10-Byte Payload. Nominal, Minimum, and Maximum Data Rate

5.4.2 5-Byte Preamble

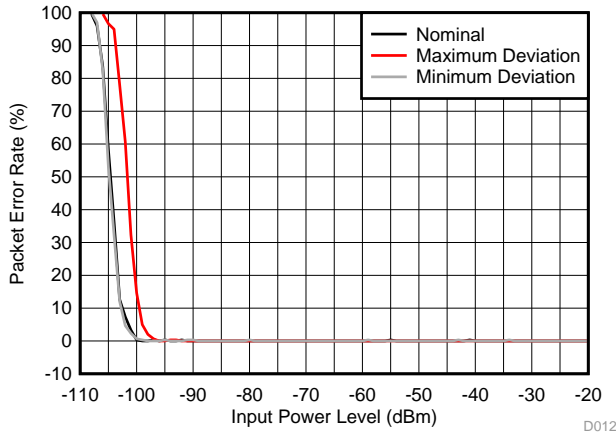

Figure 12. T-Mode PER vs Input Power Level, 5-Byte Preamble, 10-Byte Payload. Nominal, Minimum, and Maximum Deviation

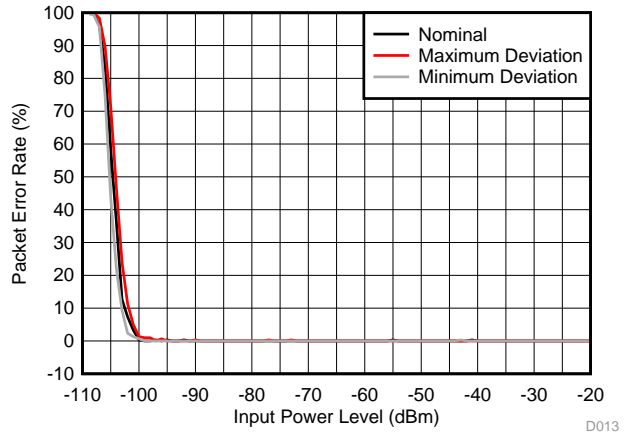

Figure 13. T-Mode PER vs Input Power Level, 5-Byte Preamble, 10-Byte Payload. Nominal, Minimum, and Maximum Data Rate

5.4.3 6-Byte Preamble

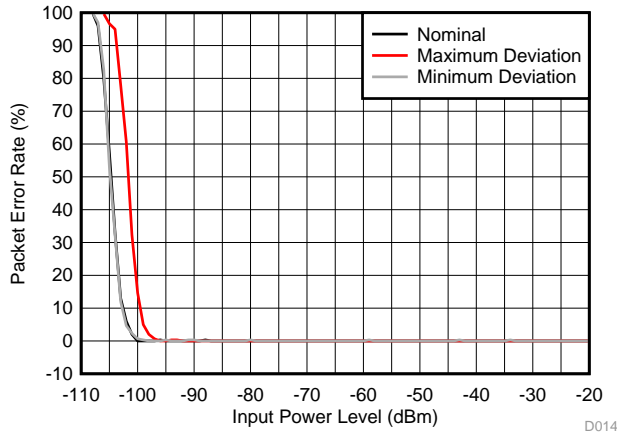

Figure 14. T-Mode PER vs Input Power Level, 6-Byte Preamble, 10-Byte Payload. Nominal, Minimum, and Maximum Deviation

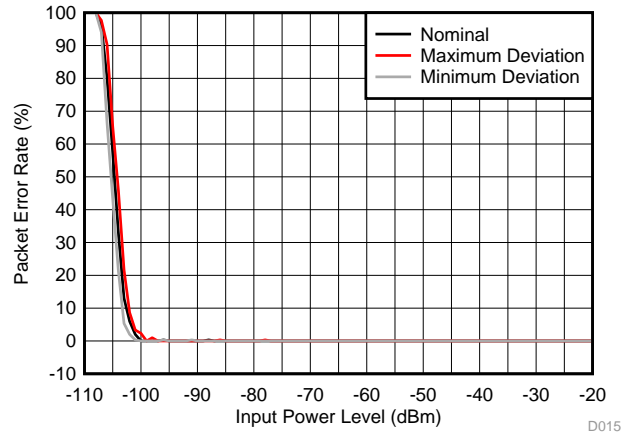

Figure 15. T-Mode PER vs Input Power Level, 6-Byte Preamble, 10-Byte Payload. Nominal, Minimum, and Maximum Data Rate

5.4.4 10-Byte Preamble

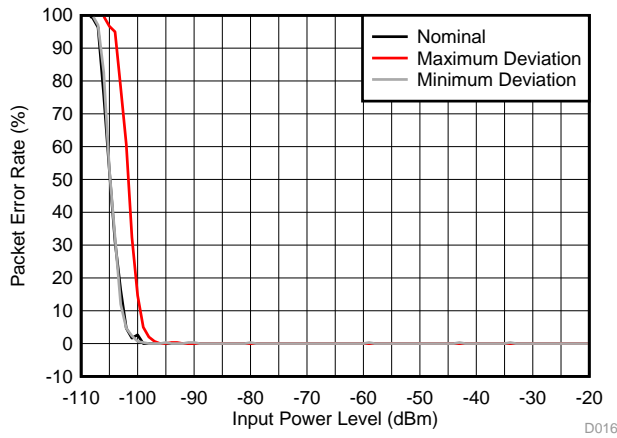

Figure 16. T-Mode PER vs Input Power Level, 10-Byte Preamble, 10-Byte Payload. Nominal, Minimum, and Maximum Deviation

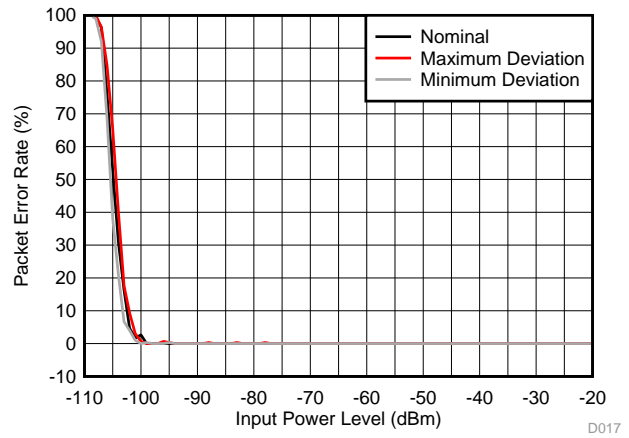

Figure 17. T-Mode PER vs Input Power Level, 10-Byte Preamble, 10-Byte Payload. Nominal, Minimum, and Maximum Data Rate

5.5 PER versus Frequency Offset

The frequency offset can be up to ± 60 ppm in T-Mode. In [Figure 18](#) through [Figure 22](#), 55% PER corresponds to 1% BER.

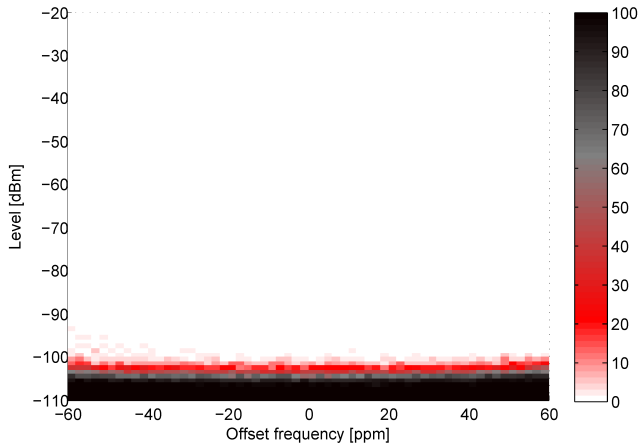

Figure 18. T-Mode 100 kcps, ± 50 kHz, 10-Byte Payload

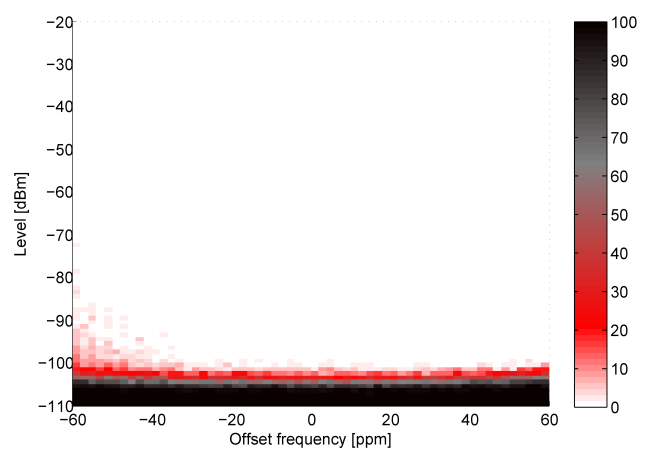

Figure 19. T-Mode 100 kcps, ± 40 kHz, 10-Byte Payload

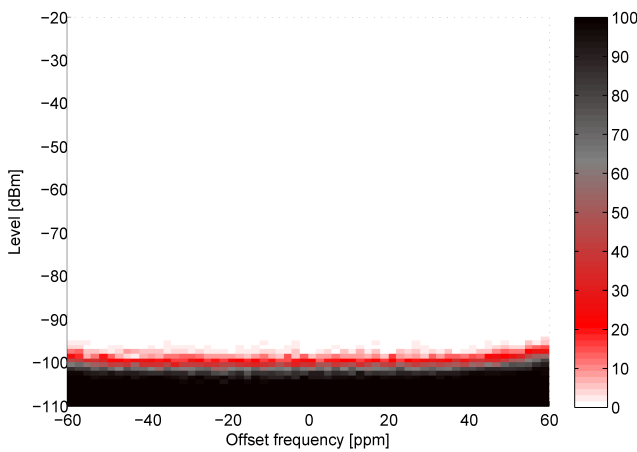

Figure 20. T-Mode 100 kcps, ± 80 kHz, 10-Byte Payload

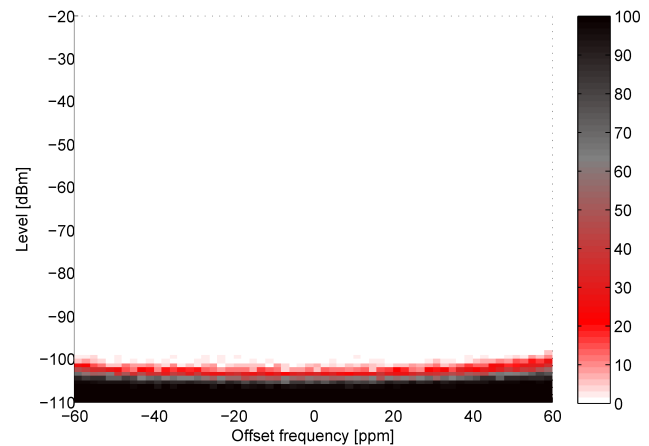

Figure 21. T-Mode 90 kcps, ± 50 kHz, 10-Byte Payload

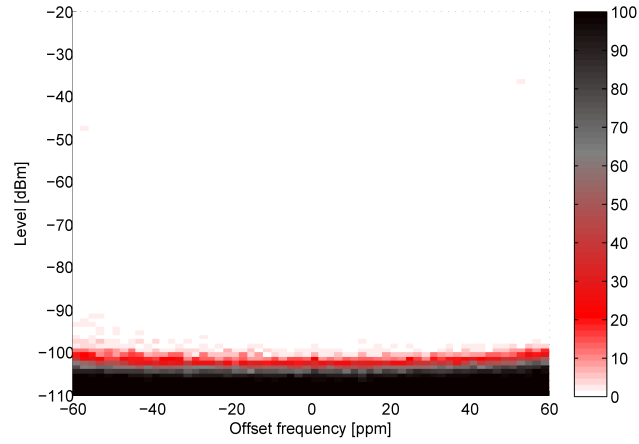

Figure 22. T-Mode 110 kcps, ± 50 kHz, 10-Byte Payload

5.6 PER versus Symbol Rate Offset

PER versus symbol rate offset was measured for nominal, minimum, and maximum deviation.

Figure 23 through Figure 25, 55% PER corresponds to 1% BER.

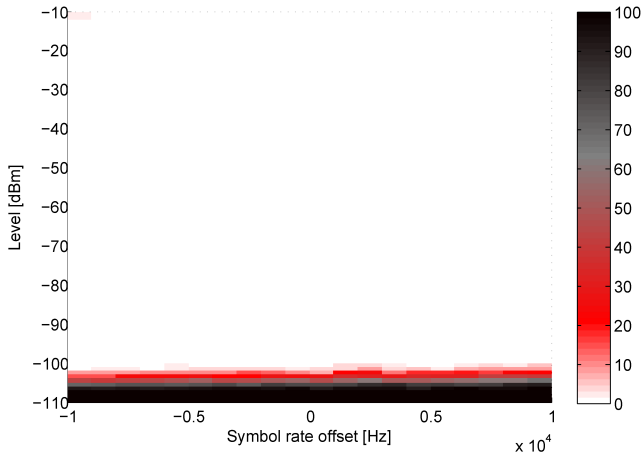

Figure 23. T-Mode ±50 kHz, 10-Byte Payload

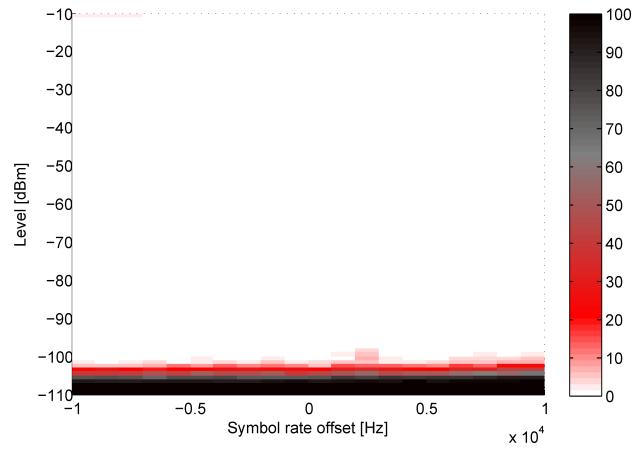

Figure 24. T-Mode ±40 kHz, 10-Byte Payload

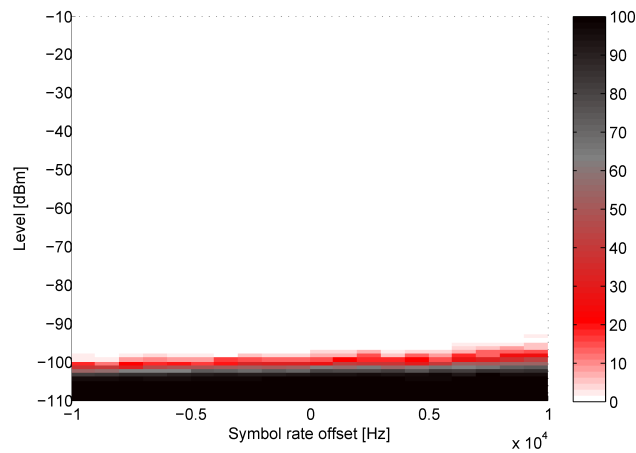

Figure 25. T-Mode ±80 kHz, 10-Byte Payload

6 References

See the following resources for more information:

1. Texas Instruments, [CC13xxEM-7793_4L](#), Reference Design
2. European Standard, EN 13757-4:2012: Communication System for Meters and Remote Reading of Meters
3. Texas Instruments, <http://www.ti.com/lit/zip/SWRA522> (.zip file with recommended settings and overrides)
4. Texas Instruments, [SmartRF Studio 7](#)
5. Texas Instruments, [SimpleLink CC13x0 Software Development Kit](#)

Revision History

NOTE: Page numbers for previous revisions may differ from page numbers in the current version.

Changes from D Revision (March 2017) to E Revision Page

- Updated the associated zip file for this document. 1
-

Changes from December 20, 2016 to March 31, 2017 Page

- Added patch/SDK information to [Section 2](#) 2
 - Added reference information for [Table 2](#) 3
 - Added reference information for [Table 3](#) 4
 - Changed [Table 3](#) 4
 - Deleted patch storage text from [Section 3](#) 5
 - Changed [Table 8](#) to only show integer numbers for the blocking 8
 - Changed [Table 11](#) to only show integer numbers for the blocking 11
-

Changes from December 5, 2016 to December 20, 2016 Page

- Changed [Table 3](#) 4
-

Changes from September 7, 2016 to December 5, 2016 Page

- Changed [Section 2.3](#) 3
 - Changed [Section 2.3.2](#) 4
 - Changed [Table 9](#) 11
 - Changed [Table 10](#) 11
 - Changed the PER in [Section 5.4](#) 11
 - Changed titles of graphs in [Section 5.4.1](#) and [Section 5.4.2](#) 12
 - Changed titles of graphs in [Section 5.4.3](#) and [Section 5.4.4](#) 12
 - Changed the PER in [Section 5.5](#) 14
 - Changed titles of graphs in [Section 5.5](#) 14
 - Changed the PER in [Section 5.6](#) 16
 - Changed titles of graphs in [Section 5.6](#) 16
 - Changed [Section 6](#) 17
-

Changes from June 22, 2016 to September 7, 2016 Page

- Made minor editorial corrections 2
-

IMPORTANT NOTICE AND DISCLAIMER

TI PROVIDES TECHNICAL AND RELIABILITY DATA (INCLUDING DATASHEETS), DESIGN RESOURCES (INCLUDING REFERENCE DESIGNS), APPLICATION OR OTHER DESIGN ADVICE, WEB TOOLS, SAFETY INFORMATION, AND OTHER RESOURCES "AS IS" AND WITH ALL FAULTS, AND DISCLAIMS ALL WARRANTIES, EXPRESS AND IMPLIED, INCLUDING WITHOUT LIMITATION ANY IMPLIED WARRANTIES OF MERCHANTABILITY, FITNESS FOR A PARTICULAR PURPOSE OR NON-INFRINGEMENT OF THIRD PARTY INTELLECTUAL PROPERTY RIGHTS.

These resources are intended for skilled developers designing with TI products. You are solely responsible for (1) selecting the appropriate TI products for your application, (2) designing, validating and testing your application, and (3) ensuring your application meets applicable standards, and any other safety, security, or other requirements. These resources are subject to change without notice. TI grants you permission to use these resources only for development of an application that uses the TI products described in the resource. Other reproduction and display of these resources is prohibited. No license is granted to any other TI intellectual property right or to any third party intellectual property right. TI disclaims responsibility for, and you will fully indemnify TI and its representatives against, any claims, damages, costs, losses, and liabilities arising out of your use of these resources.

TI's products are provided subject to TI's Terms of Sale (www.ti.com/legal/termsofsale.html) or other applicable terms available either on ti.com or provided in conjunction with such TI products. TI's provision of these resources does not expand or otherwise alter TI's applicable warranties or warranty disclaimers for TI products.

Mailing Address: Texas Instruments, Post Office Box 655303, Dallas, Texas 75265
Copyright © 2018, Texas Instruments Incorporated