

Revision History

Rev	ECN #	Approved Date	Approved by	Notes
N/A	N/A	N/A	N/A	N/A

Place Block Diagram here (if appropriate) or delete this text box.
 If using a block diagram from another tool, save the picture as a .bmp file.
 Then, use menu Place|Drawing Tools|Graphic to insert the .png/.svg/.bmp file on the schematic.

Orderable: ChangeMe in variant	Designed for: Public Release	Mod. Date: 1/24/2022	 TEXAS INSTRUMENTS http://www.ti.com © Texas Instruments 2022
TID #: N/A	Project Title: PYROFUSE DRIVER	Sheet Title:	
Number: AUTOSYS-783 Rev: E1	Assembly Variant: 001	Sheet: 1 of 3	
SVN Rev: Not in version control	File: PCB_Project.SchDoc	Size: B	
Drawn By: Bing Zou	Contact: http://www.ti.com/support		

Texas Instruments and/or its licensors do not warrant the accuracy or completeness of this specification or any information contained therein. Texas Instruments and/or its licensors do not warrant that this design will meet the specifications, will be suitable for your application or fit for any particular purpose, or will operate in an implementation. Texas Instruments and/or its licensors do not warrant that the design is production worthy. You should completely validate and test your design implementation to confirm the system functionality for your application.

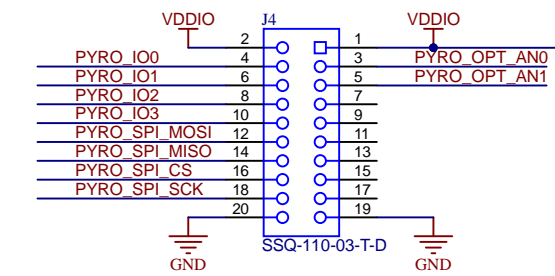
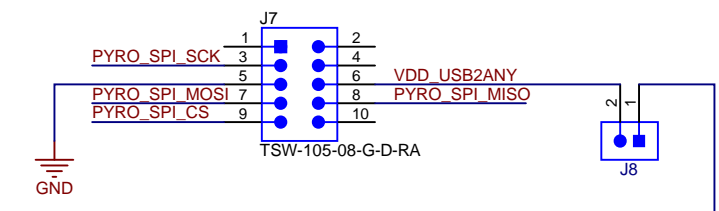
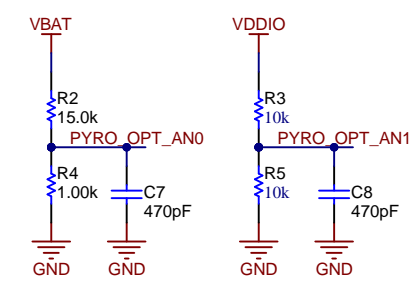
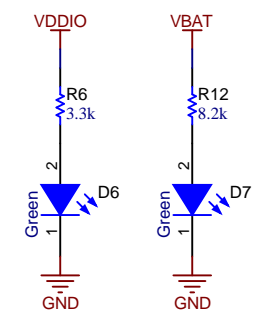
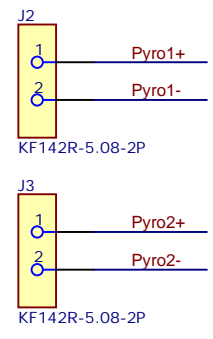
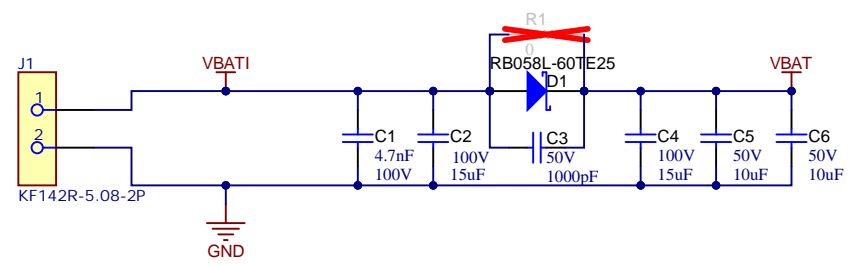

For Pyrofuse

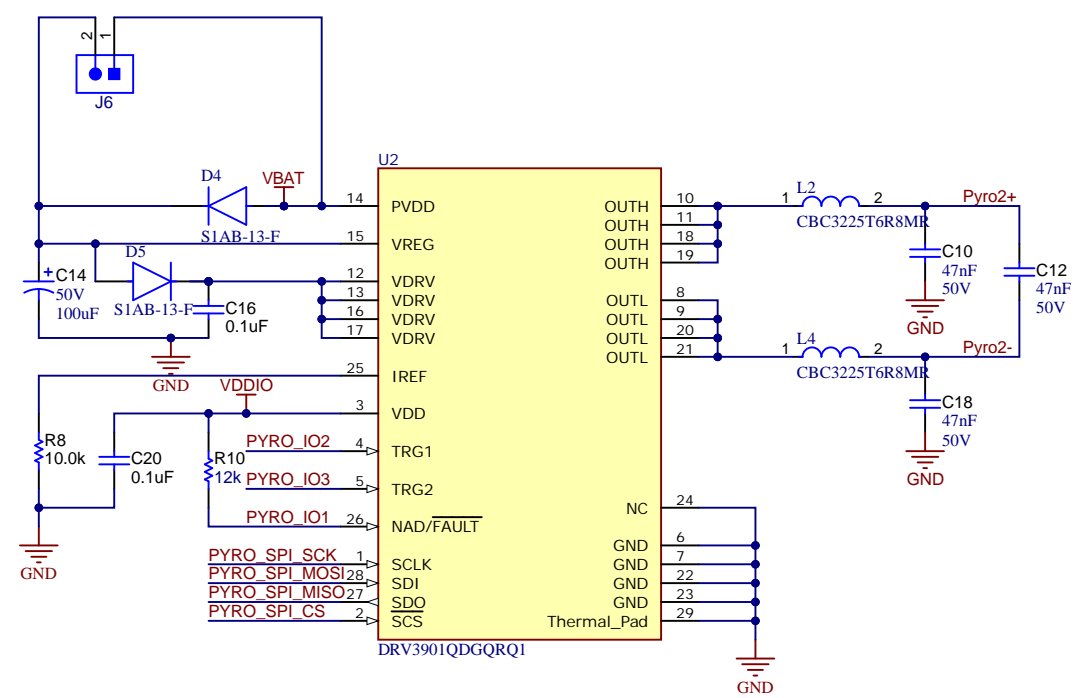
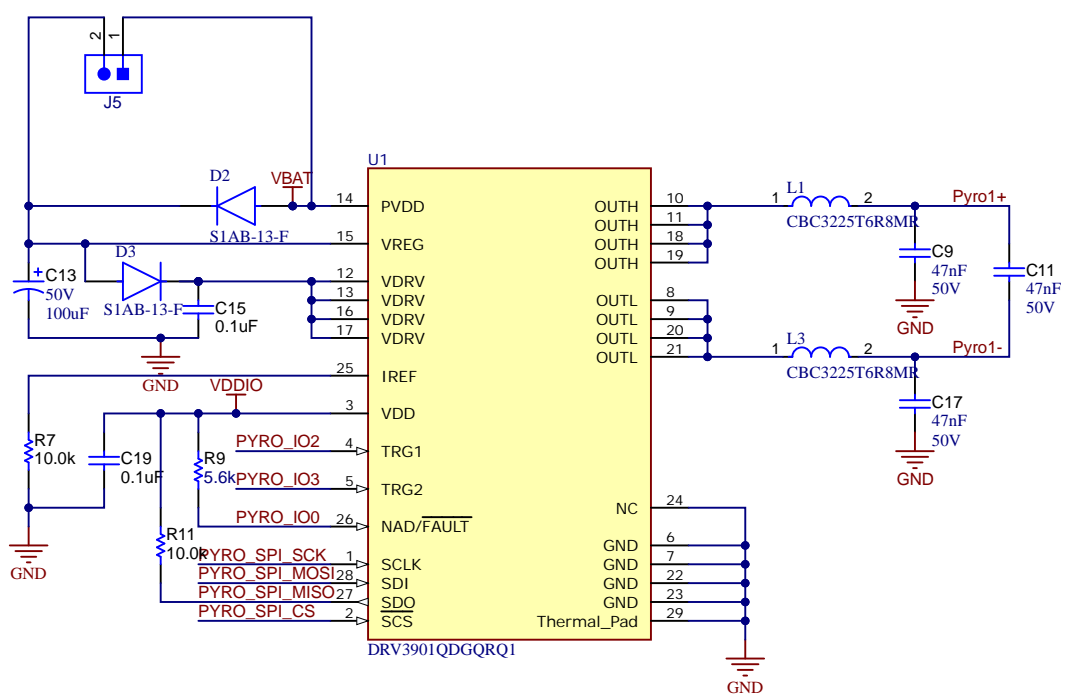

Texas Instruments and/or its licensors do not warrant the accuracy or completeness of this specification or any information contained therein. Texas Instruments and/or its licensors do not warrant that this design will meet the specifications, will be suitable for your application or fit for any particular purpose, or will operate in an implementation. Texas Instruments and/or its licensors do not warrant that the design is production worthy. You should completely validate and test your design implementation to confirm the system functionality for your application.

Orderable: ChangeMe in variant	Designed for: Public Release	Mod. Date: 7/9/2024
TID #: N/A	Project Title: PYROFUSE DRIVER	
Number: AUTOSYS-783 Rev: E1	Sheet Title:	
SVN Rev: Not in version control	Assembly Variant: 001	Sheet: 2 of 3
Drawn By:	File: BMS_Demo_Pyrofuse_Driver_Schematic.SchDoc	Size: B
Engineer: Bing Zou	Contact: http://www.ti.com/support	





PCB Number: AUTOSYS-783
PCB Rev: E1

PCB LOGO Texas Instruments PCB LOGO FCC disclaimer PCB LOGO WEEE logo PCB LOGO ESD Susceptible PCB LOGO Pb-Free Symbol

Variant/Label Table	
Variant	Label Text
001	ChangeMe!
002	ChangeMe!

LBL1
PCB Label
THT-14-423-10
Size: 0.65" x 0.20 "

ZZ1
Label Assembly Note
This Assembly Note is for PCB labels only

ZZ2
Assembly Note
These assemblies are ESD sensitive, ESD precautions shall be observed.

ZZ3
Assembly Note
These assemblies must be clean and free from flux and all contaminants. Use of no clean flux is not acceptable.

ZZ4
Assembly Note
These assemblies must comply with workmanship standards IPC-A-610 Class 2, unless otherwise specified.

Orderable: ChangeMe in variant	Designed for: Public Release	Mod. Date: 6/27/2022
TID #: N/A	Project Title: PYROFUSE DRIVER	
Number: AUTOSYS-783 Rev: E1	Sheet Title:	
SVN Rev: Not in version control	Assembly Variant: 001	Sheet: 3 of 3
Drawn By:	File: BMS_Demo_Pyrofuse_Driver_Hardware.SchDoc	Size: B
Engineer: Bing Zou	Contact: http://www.ti.com/support	



Texas Instruments and/or its licensors do not warrant the accuracy or completeness of this specification or any information contained therein. Texas Instruments and/or its licensors do not warrant that this design will meet the specifications, will be suitable for your application or fit for any particular purpose, or will operate in an implementation. Texas Instruments and/or its licensors do not warrant that the design is production worthy. You should completely validate and test your design implementation to confirm the system functionality for your application.

IMPORTANT NOTICE AND DISCLAIMER

TI PROVIDES TECHNICAL AND RELIABILITY DATA (INCLUDING DATA SHEETS), DESIGN RESOURCES (INCLUDING REFERENCE DESIGNS), APPLICATION OR OTHER DESIGN ADVICE, WEB TOOLS, SAFETY INFORMATION, AND OTHER RESOURCES "AS IS" AND WITH ALL FAULTS, AND DISCLAIMS ALL WARRANTIES, EXPRESS AND IMPLIED, INCLUDING WITHOUT LIMITATION ANY IMPLIED WARRANTIES OF MERCHANTABILITY, FITNESS FOR A PARTICULAR PURPOSE OR NON-INFRINGEMENT OF THIRD PARTY INTELLECTUAL PROPERTY RIGHTS.

These resources are intended for skilled developers designing with TI products. You are solely responsible for (1) selecting the appropriate TI products for your application, (2) designing, validating and testing your application, and (3) ensuring your application meets applicable standards, and any other safety, security, regulatory or other requirements.

These resources are subject to change without notice. TI grants you permission to use these resources only for development of an application that uses the TI products described in the resource. Other reproduction and display of these resources is prohibited. No license is granted to any other TI intellectual property right or to any third party intellectual property right. TI disclaims responsibility for, and you will fully indemnify TI and its representatives against, any claims, damages, costs, losses, and liabilities arising out of your use of these resources.

TI's products are provided subject to [TI's Terms of Sale](#) or other applicable terms available either on [ti.com](https://www.ti.com) or provided in conjunction with such TI products. TI's provision of these resources does not expand or otherwise alter TI's applicable warranties or warranty disclaimers for TI products.

TI objects to and rejects any additional or different terms you may have proposed.

Mailing Address: Texas Instruments, Post Office Box 655303, Dallas, Texas 75265
Copyright © 2024, Texas Instruments Incorporated